

QSP-8229A

Quad Split User Manual

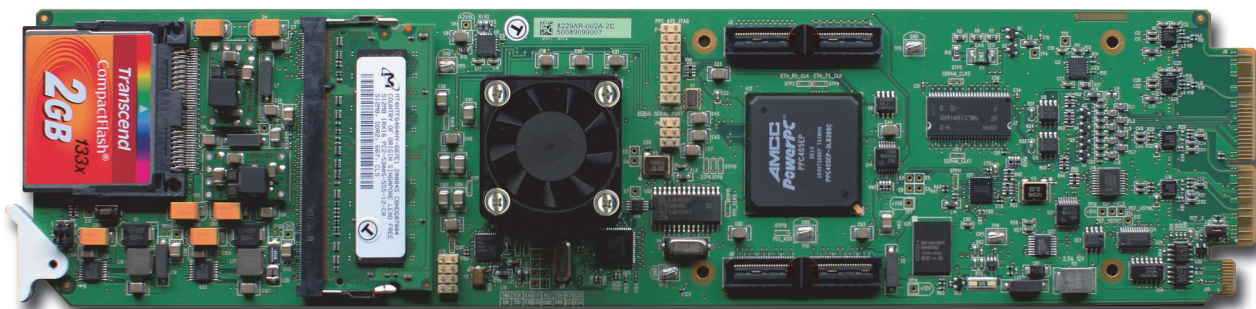

QSP-8229A User Manual

- Ross Part Number: 8229ADR-004-01
- Release Date: June 15, 2012.

The information in this manual is subject to change without notice or obligation.

Copyright

© 2012 Ross Video Limited. All rights reserved.

Contents of this publication may not be reproduced in any form without the written permission of Ross Video Limited. Reproduction or reverse engineering of copyrighted software is prohibited.

Patents

This product is protected by the following US Patents: 4,205,346; 5,115,314; 5,280,346; 5,561,404; 7,304,886; 7,508,455; 7,602,446; 7,834,886; 7,914,332. This product is protected by the following Canadian Patents: 2039277; 1237518; 1127289. Other patents pending.

Notice

The material in this manual is furnished for informational use only. It is subject to change without notice and should not be construed as commitment by Ross Video Limited. Ross Video Limited assumes no responsibility or liability for errors or inaccuracies that may appear in this manual.

Trademarks



-  is a registered trademark of Ross Video Limited.
- Ross, ROSS, ROSS®, and MLE are registered trademarks of Ross Video Limited.
- openGear® is a registered trademark of Ross Video Limited.
- DashBoard Control System™ is a trademark of Ross Video Limited.
- SanDisk® and CompactFlash® are registered trademarks of SanDisk Corporation, registered in the United States and other countries.
- All other product names and any registered and unregistered trademarks mentioned in this manual are used for identification purposes only and remain the exclusive property of their respective owners.

Important Regulatory and Safety Notices to Service Personnel

Before using this product and any associated equipment, refer to the “**Important Safety Instructions**” listed below to avoid personnel injury and to prevent product damage.

Product may require specific equipment, and/or installation procedures to be carried out to satisfy certain regulatory compliance requirements. Notices have been included in this publication to call attention to these specific requirements.

Symbol Meanings



This symbol on the equipment refers you to important operating and maintenance (servicing) instructions within the Product Manual Documentation. Failure to heed this information may present a major risk of damage to persons or equipment.



Warning — The symbol with the word “**Warning**” within the equipment manual indicates a potentially hazardous situation, which, if not avoided, could result in death or serious injury.



Caution — The symbol with the word “**Caution**” within the equipment manual indicates a potentially hazardous situation, which, if not avoided, may result in minor or moderate injury. It may also be used to alert against unsafe practices.



Notice — The symbol with the word “**Notice**” within the equipment manual indicates a potentially hazardous situation, which, if not avoided, may result in major or minor equipment damage or a situation which could place the equipment in a non-compliant operating state.



ESD Susceptibility — This symbol is used to alert the user that an electrical or electronic device or assembly is susceptible to damage from an ESD event.

Important Safety Instructions



Caution — This product is intended to be a component product of the DFR-8300 series frame. Refer to the DFR-8300 Series Frame User Manual for important safety instructions regarding the proper installation and safe operation of the frame as well as its component products.



Warning — Certain parts of this equipment namely the power supply area still present a safety hazard, with the power switch in the OFF position. To avoid electrical shock, disconnect all A/C power cords from the chassis’ rear appliance connectors before servicing this area.



Warning — Service barriers within this product are intended to protect the operator and service personnel from hazardous voltages. For continued safety, replace all barriers after any servicing.

This product contains safety critical parts, which if incorrectly replaced may present a risk of fire or electrical shock. Components contained with the product’s power supplies and power supply area, are not intended to be customer serviced and should be returned to the factory for repair. To reduce the risk of fire, replacement fuses must be the same time and rating. Only use attachments/accessories specified by the manufacturer.



Warning — *This product includes an “Ethernet Port” which allows this product to be connected to a local area network (LAN). Only connect to networks that remain inside the building. Do not connect to networks that go outside the building.*

EMC Notices

United States of America FCC Part 15

This equipment has been tested and found to comply with the limits for a class A Digital device, pursuant to part 15 of the FCC Rules. These limits are designed to provide reasonable protection against harmful interference when the equipment is operated in a commercial environment. This equipment generates, uses, and can radiate radio frequency energy and, if not installed and used in accordance with the instruction manual, may cause harmful interference to radio communications. Operation of this equipment in a residential area is likely to cause harmful interference in which case the user will be required to correct the interference at their own expense.



Notice — *Changes or modifications to this equipment not expressly approved by Ross Video Limited could void the user’s authority to operate this equipment.*

CANADA

This Class “A” digital apparatus complies with Canadian ICES-003.

Cet appareil numérique de la classe “A” est conforme a la norme NMB-003 du Canada.

EUROPE

This equipment is in compliance with the essential requirements and other relevant provisions of CE Directive 93/68/EEC.

INTERNATIONAL

This equipment has been tested to **CISPR 22:1997** along with amendments **A1:2000** and **A2:2002**, and found to comply with the limits for a Class A Digital device.



Notice — *This is a Class A product. In domestic environments, this product may cause radio interference, in which case the user may have to take adequate measures.*

Maintenance/User Serviceable Parts

Routine maintenance to this openGear product is not required. This product contains no user serviceable parts. If the module does not appear to be working properly, please contact Technical Support using the numbers listed under the “Contact Us” section on the last page of this manual. All openGear products are covered by a generous 5-year warranty and will be repaired without charge for materials or labor within this period. See the “Warranty and Repair Policy” section in this manual for details.

Environmental Information

The equipment that you purchased required the extraction and use of natural resources for its production. It may contain hazardous substances that could impact health and the environment.

To avoid the potential release of those substances into the environment and to diminish the need for the extraction of natural resources, Ross Video encourages you to use the appropriate take-back systems. These systems will reuse or recycle most of the materials from your end-of-life equipment in an environmentally friendly and health conscious manner.

The crossed out wheelee bin symbol invites you to use these systems.



If you need more information on the collection, re-use, and recycling systems, please contact your local or regional waste administration.

You can also contact Ross Video for more information on the environmental performance of our products.

Company Address



Ross Video Limited

8 John Street
Iroquois, Ontario, K0E 1K0
Canada

Ross Video Incorporated

P.O. Box 880
Ogdensburg, New York
USA 13669-0880

General Business Office: (+1) 613 • 652 • 4886

Fax: (+1) 613 • 652 • 4425

Technical Support: (+1) 613 • 652 • 4886

After Hours Emergency: (+1) 613 • 349 • 0006

E-mail (Technical Support): techsupport@rossvideo.com

E-mail (General Information): solutions@rossvideo.com

Website: <http://www.rossvideo.com>

Contents

- Introduction 1**
 - In This Chapter 1-1
 - Overview..... 1-2
 - Features..... 1-2
 - Functional Block Diagrams 1-3
 - Non-Looping Configuration (8310AR-033, 8320AR-033) 1-3
 - Looping Configuration (8320AR-049)..... 1-4
 - Documentation Terms..... 1-5

- Installation 2**
 - In This Chapter 2-1
 - Before You Begin 2-2
 - Card Overview 2-3
 - Card-edge LEDs 2-4
 - Card Installation..... 2-5
 - Rear Modules..... 2-5
 - Installing the Rear Modules..... 2-6
 - Cabling Overview 2-8
 - Non-Looping Rear Modules (8310AR-033, 8320AR-033) 2-8
 - Looping Rear Module (8320AR-049) 2-9
 - Ethernet Port Cabling..... 2-10
 - Ethernet Communication Cabling 2-10
 - GPI Cabling 2-11
 - GPI Cable Connections 2-11
 - Tally Cabling 2-12
 - GPI Port Cabling 2-12
 - Serial Port Cabling 2-12
 - Ethernet Port Cabling 2-13

- Configuration 3**
 - In This Chapter 3-1
 - Selecting the Video Format and Reference Source 3-2
 - Selecting the Video Format and Reference Source 3-2
 - Output Format Reference Compatibility 3-3
 - Video Input and Output Configuration 3-4
 - Configuring the Video Outputs 3-4
 - Configuring the Input Signal Timing Display..... 3-5
 - Signal Loss Alarm Setup 3-5
 - Ethernet Communication Setup 3-7
 - GPI Communication Setup 3-8
 - GPI Overview 3-8
 - GPI Communication Setup..... 3-8
 - Tally Communication Setup 3-10
 - Enable the Tally UMD Feature 3-10
 - Set up Communications..... 3-10

Loading the Factory Defaults	3-14
Software Upgrades	3-15
Operation	4
In This Chapter	4-1
Adjusting the Proc Amp Controls	4-2
Configuring the Quad Split Sources	4-4
Assigning Sources to the Quad Split	4-4
Applying a Border	4-5
Notes on Timing.....	4-6
Appendix A. DashBoard Menus	5
In This Appendix.....	5-1
Status Tabs	5-2
Signal Tab	5-2
Hardware Tab	5-3
Configuration Tabs.....	5-5
Video Configuration	5-5
GPI/Tally Configuration	5-6
Ethernet Configuration	5-8
Personality Configuration.....	5-9
Load/Save	5-9
Proc Amps Tab.....	5-10
Quad Split Tabs.....	5-11
Video/Label Tab	5-11
Tally/Border Tab	5-11
Bkgd A, B, C, D Tabs.....	5-12
Appendix B. Specifications	6
In This Appendix.....	6-1
8310AR-033 and 8320AR-033 Specifications.....	6-2
8320AR-049 Specifications	6-3
Appendix C. Service Information	7
In This Chapter.....	7-1
Troubleshooting Checklist	7-2
Warranty and Repair Policy	7-3

Introduction

In This Chapter

This chapter contains the following sections:

- Overview
- Functional Block Diagrams
- Documentation Terms

A Word of Thanks

Congratulations on your purchase of the openGear **QSP-8229A Quad Split**. The QSP-8229A is part of a full line of Ross Video products which are backed by over 25 years of engineering and design expertise. You will be pleased at how easily your new card fits into your overall working environment. Equally pleasing is the product quality, reliability, and functionality.

Should you have a question pertaining to the installation or operation of your QSP-8229A, please contact us at the numbers listed in the section “**Contact Us**” located at the back of this manual. Our technical support staff is always available for consultation, training, or service.

Overview

The QSP-8229A takes four SDI input streams and can reduce them into four quadrants in a single stream. The QSP-8229A has four SDI outputs which can be independently configured to display either the full-screen input or the Quad Split stream. When the output is showing full-screen, all HANC and VANC data, including the embedded audio data on the input is carried through to the output. When the output is showing Quad Split, all HANC and VANC data, including embedded audio, is stripped.

In addition, the 8320AR-049 Rear Module was designed to be used with the QSP-8229A in the DFR-8321 series frames to loop its inputs to a system, such as the Carbonite® production switcher, for a multi-viewer application.

GPI control allows external devices to choose which of the input selections, including the Quad Split, will be assigned to the outputs.

Features

The following features are included for the QSP-8229A:

- Compliance with SDI SMPTE 292M (1.485Gbps) and SMPTE 259M (270Mbps)
- Multi-Definition support of popular formats such as 1080i, 720p, 480i, 576i, 1080pSF
- Assign any input, or Black, to any quadrant
- Text overlay to name the four input sources in the Quad Split
- Configure GPIs to trigger any of the outputs or a specific quadrant
- On-screen tallies controlled by GPI, serial protocol (TSL UMD v3.1) or ethernet (TSL over UDP/TCP); quadrant text labels are updated dynamically
- Specify how the input signal timing is reported (relative to the reference or the output)
- Bypass relay from BKGD A input to Output 1 (*8310AR-033 and 8320AR-033 Rear Modules only*)
- Four passive looping inputs (*8320AR-049 Rear Module only*)
- User selectable card analog reference
- Report status and configuration remotely via the DashBoard Control System™
- Ethernet 10/100 Mbit connectivity for easy upgrades in the field
- Independent Proc-Amp control on outputs
- Full DashBoard control and monitoring
- Fully compliant with openGear specifications and installs in the DFR-8300 series frames
- 5 year transferable warranty

Functional Block Diagrams

This section provides the functional block diagrams for the QSP-8229A.

Non-Looping Configuration (8310AR-033, 8320AR-033)

This section includes the block diagram when using the QSP-8229A with the 8310AR-033 or 8320AR-033 Rear Modules.

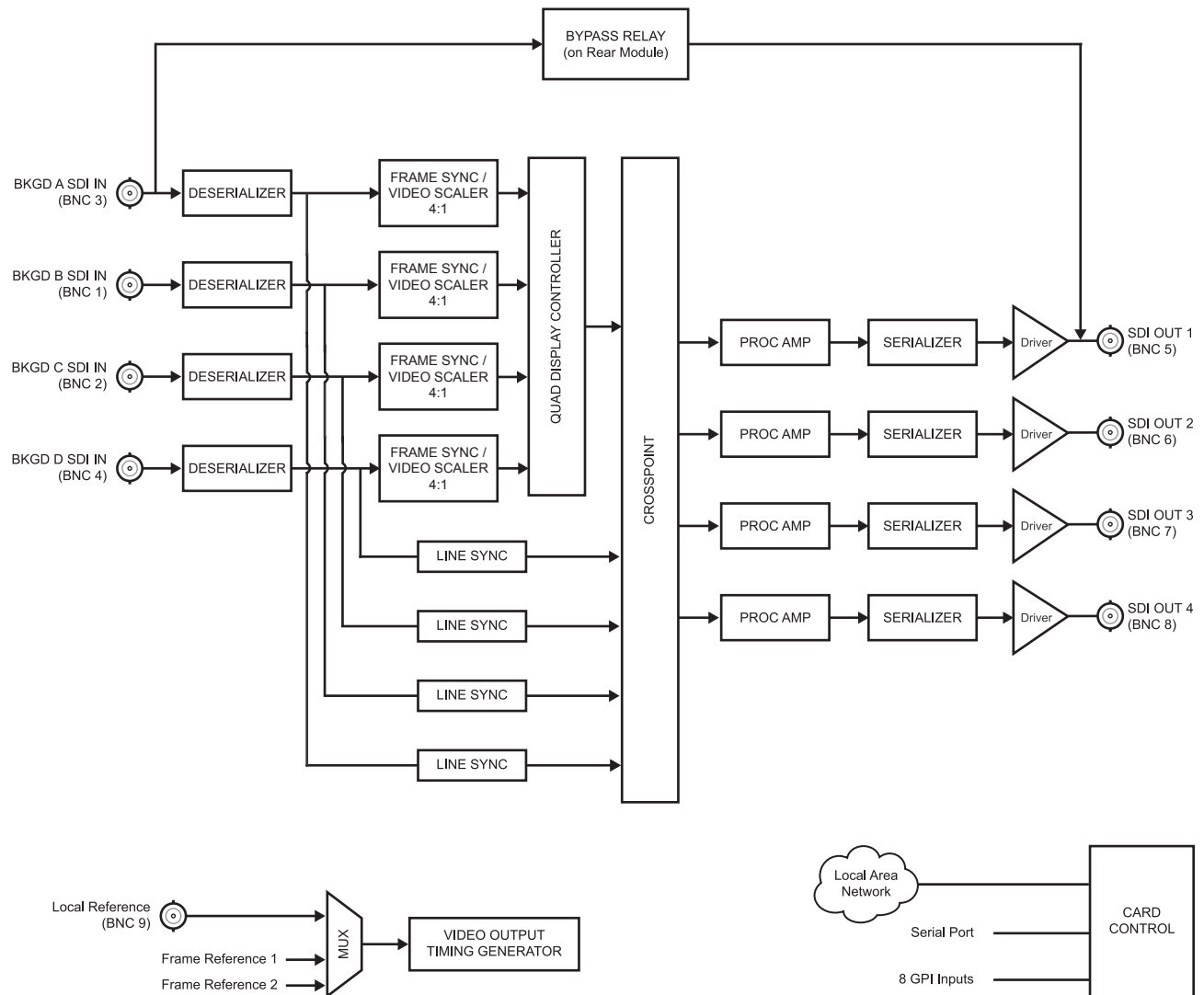

Figure 1.1 QSP-8229A Block Diagram — 8310AR-033 and 8310AR-033 Rear Modules

Looping Configuration (8320AR-049)

This section includes the block diagram when using the QSP-8229A with the 8320AR-049 Rear Module.

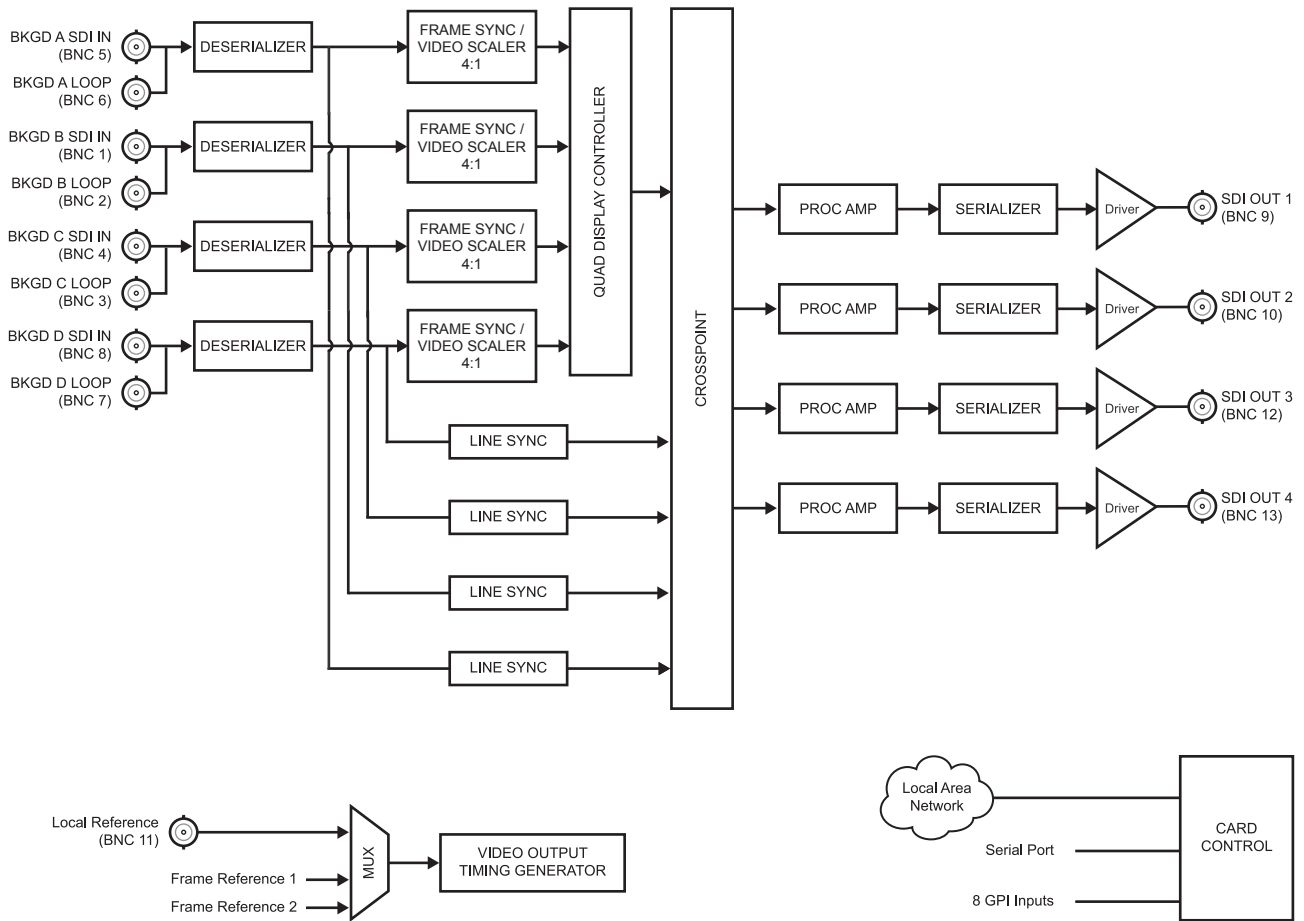

Figure 1.2 QSP-8229A Block Diagram — 8320AR-049 Rear Module

Documentation Terms

The following terms are used throughout this manual:

- All references to the **DFR-8300 series frames** also includes all versions of the 10-slot and 20-slot frames and any available options unless otherwise noted.
- “**Bkgd**” refers to a Background source (A, B, C, or D).
- “**Board**” or “**Card**” refers to the QSP-8229A, including all components and switches unless otherwise noted.
- “**DashBoard**” refers to the DashBoard Control System™.
- “**LL**” refers to the Lower Left quadrant.
- “**Looping Rear Module**” refers to the 8320AR-049 Rear Module.
- “**LR**” refers to the Lower Right quadrant.
- “**Non-looping rear module**” refers to the 8310AR-033 or 8320AR-033 Rear Modules unless otherwise stated.
- “**Operator**” and “**User**” refers to the person who uses the QSP-8229A.
- “**System**” and “**Video System**” refers to the mix of interconnected digital and analog production equipment in which the QSP-8229A operates.
- “**UL**” refers to the Upper Left quadrant.
- “**UR**” refers to the Upper Right quadrant.

Installation

In This Chapter

This chapter provides instructions for the basic physical installation and communications setup of your QSP-8229A.

The following topics are discussed:

- Before You Begin
- Card Overview
- Card Installation
- Cabling Overview
- Ethernet Port Cabling
- GPI Cabling
- Tally Cabling

Before You Begin

Before you begin, ensure that you are using DashBoard version 4.0.0 or higher. The DashBoard Control System software and user manual are available to download from the Ross Video website.

Static Discharge

Throughout this chapter, please heed the following cautionary note:



ESD Susceptibility — *Static discharge can cause serious damage to sensitive semiconductor devices. Avoid handling circuit boards in high static environments such as carpeted areas and when synthetic fiber clothing is worn. Always exercise proper grounding precautions when working on circuit boards and related equipment.*

Unpacking

Unpack each card you received from the shipping container and ensure that all items are included. If any items are missing or damaged, contact your sales representative or Ross Video directly.

Card Overview

This section provides an overview of the QSP-8229A components.

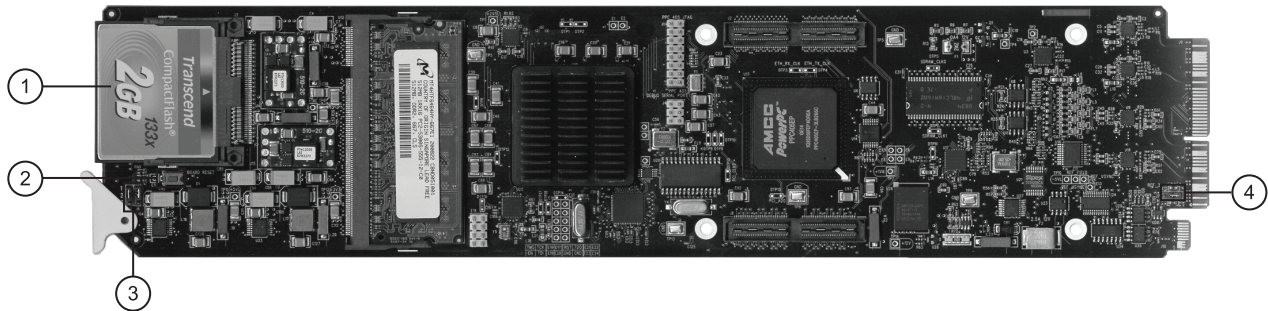

Figure 2.1 Card-edge Components

1) CompactFlash® Card	3) JP5, JP6
2) Board Reset Button (SW1)	4) Reference Termination (JP7)

1. CompactFlash® Card

The CompactFlash® card is reserved for future usage.

2. Board Reset Button (SW1)

Pressing this button resets the microprocessor and re-initializes the card. This is a hard reset of the card and settings are not saved. This may cause loss of data and should only be performed as advised by Ross Video Technical Support.

3. JP5, JP6

These jumpers are not yet implemented and must be left in the default position of **Pin 2** (center) and **Pin 3** (bottom).

4. Reference Termination (JP7)

JP7 is a 3-position jumper block used to configure the 75ohm termination on the local analog reference input on **BNC 9** of the 8310AR-033 and 8320AR-033 Rear Modules, or **BNC 11** of the 8320AR-049 Rear Module.

- **Pin 1** (left) + **Pin 2** (center) position — In this position, the analog reference is terminated with a 75 Ohm resistor. This configuration is to be used for point-to-point cabling, or on the last card of a daisy chain topology. This is the default position (**Figure 2.2**).

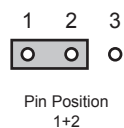

Figure 2.2 JP7 — Default Position

- **Pin 2** (center) + **Pin 3** (right) position — In this position, the 75ohm terminator is removed and the analog reference is not terminated. This configuration is used in a daisy chain cabling topology where only the last card is terminated.

Card-edge LEDs

This section describes the card-edge LEDs. **Figure 2.3** outlines the locations of the card-edge controls.

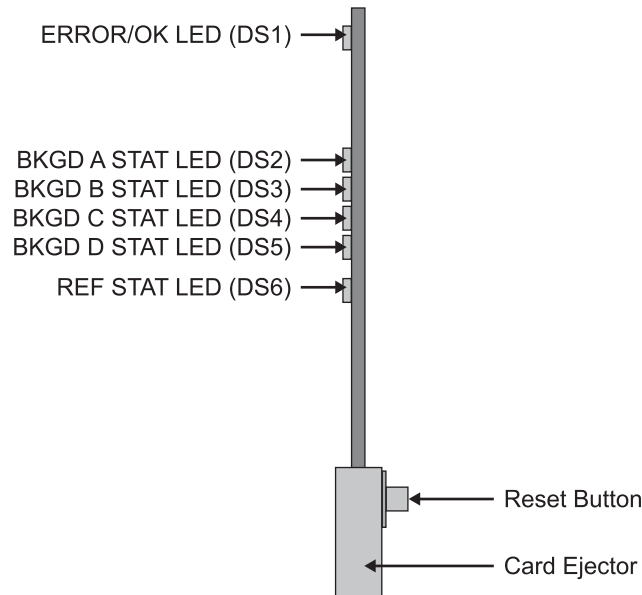

Figure 2.3 Card-edge Controls

Table 2.1 LEDs on the Card-edge

LED	Color	Display and Description
ERROR/OK	Green	When this LED is green, the card is in normal operation with no errors.
	Red	When this LED is red, the card is experiencing internal errors.
	Off	When this LED is off, there is no power to the card.
BKGD A STAT	Green	When this LED is green, the Bkgd A video input is valid.
	Red	When this LED is red, the Bkgd A input is not present or is invalid.
BKGD B STAT	Green	When this LED is green, the Bkgd B video input is valid.
	Red	When this LED is red, the Bkgd B input is not present or is invalid.
BKGD C STAT	Green	When this LED is green, the Bkgd C input is valid.
	Red	When this LED is red, the Bkgd C input is not present or is invalid.
BKGD D STAT	Green	When this LED is green, the Bkgd D input is valid.
	Red	When this LED is red, the Bkgd D input is not present or is invalid.
REF STAT	Green	When this LED is green, the reference signal is valid.
	Red	When this LED is red, the reference signal is not present or is invalid.

Card Installation

This section provides a brief overview of the required Rear Modules and physical installation of the QSP-8229A.



Note — *The QSP-8229A requires either the 8310AR-033 or the 8320AR-033 Rear Module and therefore is not compatible with the DFR-8310-BNC frames.*

You must install the card with its 8310AR-033 Rear Module, occupying two slots in a DFR-8310-C, or a DFR-8310-N frame. To install the card in the DFR-8321 series frame, you must use the 8320AR-033 or 8320AR-049 Rear Module, with each rear module occupying four slots in the frame.

Rear Modules

The procedure for installing the Rear Module in your openGear frame is the same regardless of the frame or module used. However, a different module is required depending on the openGear frame you are using. The Rear Module requires two slots in an openGear DFR-8310 series frame and four slots in an DFR-8321 series frame.

The rear module you install for the card depends on the frame you are using.

- **DFR-8310 series frame** — Use the **8310AR-033** Rear Module.
- **DFR-8321 series frame** — Use the **8320AR-033** or the **8320AR-049** Rear Modules.

Power Fail Relay

The 8310AR-033 or 8320AR-033 Rear Modules provide a built in bypass relay from BKGD A to Output 1 protects your on-air feed when the device is taken off-line and ensures critical program content is not lost.

The purpose of this relay is as follows:

- When the card is removed from the frame, the relay passes video from the BKGD A input to the Output 1 of the card. This allows the card to be serviced without interrupting the video signal.
- If the card loses power, or the frame loses power, the video still passes through.
- When the card boots, the relay will be left in Bypass mode until the card can generate a valid output. Once the card is up and functional, the relay is disabled.

8320AR-049 Rear Module

The 8320AR-049 Rear Module provides a passive looping BNC on all four SDI inputs (Bkgd A, B, C, and D). The SDI source signal should be connected to the BNC IN input and if required, the SDI input signal may be propagated to one more downstream equipment using the associated BNC Loop output. Refer to the section “**Looping Rear Module (8320AR-049)**” on page 2-9 for BNC designations and for additional cabling information.

- If you are using the BNC Loop output(s), then the looping SDI cable must drive only one piece of downstream equipment properly terminated with a 75ohm load at all time. If the downstream equipment must be disconnected for servicing, it is recommended to first disconnect the cable at the BNC Loop output of the 8320AR-049 Rear Module, otherwise the looping cable without termination will cause signal reflection that will likely corrupt the QSP-8229A SDI input signal.
- If you are not using the looping output, then the BNC Loop should be left open without any cable or standalone 75ohm termination attached to the BNC.

Installing the Rear Modules

If the Rear Module is already installed, skip this section.

To install a rear module in an DFR-8300 series frame

1. Refer to the *DFR-8300 Series User Manual* to ensure that the frame is properly installed according to instructions.
2. If you are installing the QSP-8229A in a **DFR-8310 series frame**, Ross Video recommends installing the Rear Module in one of the following combinations:
 - Slots 3, 4
 - Slots 5, 6
 - Slots 7, 8
 - Slots 9, 10



Note — Ross Video does not recommend installing the card in the Slots 1,2 combination in a DFR-8310 series frame. This combination provides the least air flow cooling in the frame.

3. If you are installing the **8320AR-033** Rear Module in a **DFR-8321 series frame**, Ross Video recommends installing the Rear Module in one of the following combinations:
 - Slots 5, 6, 7, 8
 - Slots 9, 10, 11, 12
 - Slots 13, 14, 15, 16
 - Slots 17, 18, 19, 20



Note — Ross Video does not recommend installing the card in the Slots 1,2, 3, 4 combination in a DFR-8321 series frame. This combination provides the least air flow cooling in the frame.

4. If you are installing the **8320AR-049** Rear Module in a **DFR-8321 series frame**, Ross Video recommends installing the Rear Module in one of the following combinations:
 - Slots 5, 6, 7, 8
 - Slots 9, 10, 11, 12
 - Slots 13, 14, 15, 16
 - Slots 17, 18, 19, 20
5. Remove the Blank Plates from the rear of the selected card frame slots.
6. Seat the bottom of the Rear Module in the seating slot at the base of the backplane of the frame.
7. Align the top holes of the Rear Module with the screw holes on the top-edge of the frame backplane.
8. Verify that the QSP-8229A aligns with the Rear Module before fully tightening any of the slot screws.
9. Using a Phillips screwdriver and the supplied screws, fasten the Rear Module to the backplane. Do not over tighten.
10. Verify whether your Rear Module Label is self-adhesive by checking the back of the label for a thin wax sheet. You must remove the wax sheet before affixing the label.
11. Affix the supplied Rear Module Label to the BNC area of the Rear Module.
12. Ensure proper frame cooling and ventilation by having all rear frame rails covered with Rear Modules or Blank Plates.

Installing the Card

Use the following procedure to install the card in an DFR-8300 series frame:

1. Ensure that the DFR-8300 series frame is properly installed.
2. If you are installing the QSP-8229A in a **DFR-8310 series frame**, install the card into an odd-numbered slot (e.g. slot 5, 7, or 9).
3. If you are installing the QSP-8229A in a **DFR-8321 series frame** and depending on the rear module and slot combination you chose for the rear module, install the card into one of the following slots:
 - **8320AR-033** Rear Module — Install the card in slot 6, 10, 14, or 18.
 - **8320AR-049** Rear Module — Install the card in slot 7, 11, 15, or 19.
4. Hold the card by the edges and carefully align the card edges with the rails in the frame.
5. Fully insert the card into the frame until the card is properly seated in the Rear Module.

Cabling Overview

The QSP-8229A features four video inputs and four video outputs. This section provides general instructions for video input and output cabling the Rear Module for the cards.

Non-Looping Rear Modules (8310AR-033, 8320AR-033)

This section provides information when cabling the 8310AR-033 and 8320AR-033 Rear Modules. These rear modules do not support the looping feature. Refer to **Figure 2.4** and **Figure 2.5** for cabling designations when installing the 8310AR-033 and 8320AR-033 Rear Modules respectively.

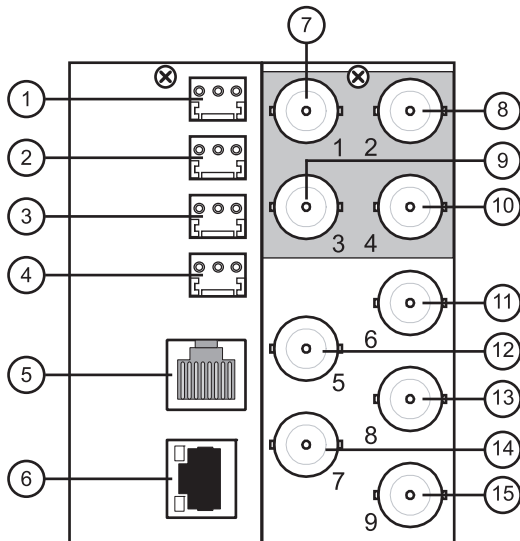

Figure 2.4 8310AR-033 Cable Connections

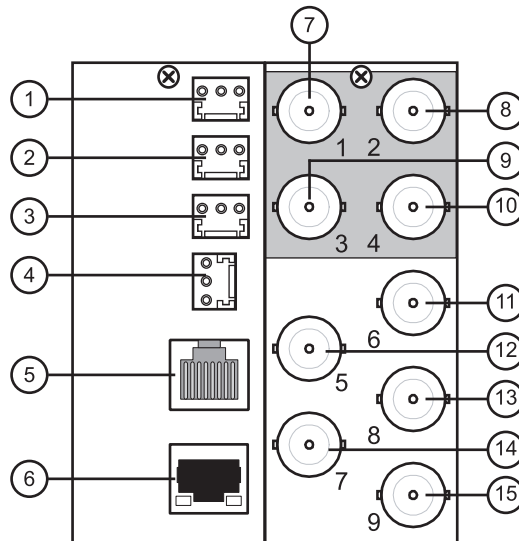

Figure 2.5 8320AR-033 Cable Connections

1) GPI 1,2 Port	6) Ethernet 10/100 Port	11) OUT 2 BNC
2) GPI 3,4 Port	7) Bkgd B In BNC	12) OUT 1 BNC
3) GPI 5,6 Port	8) Bkgd C In BNC	13) OUT 4 BNC
4) GPI 7,8 Port	9) Bkgd A In BNC	14) OUT 3 BNC
5) Serial COM Port	10) Bkgd D In BNC	15) REF IN BNC

Cabling for Non-Looping Rear Modules

You can use up to 80m of industry standard 75ohm coaxial cable with these rear modules.

Use the following procedure to connect video input and output cables to the Rear Module:

1. Connect the appropriate input video sources to the BNC connectors on the Rear Module.
2. Connect the output BNC connectors as required for your facility.
3. To use an external reference source other than the Frame Ref 1 and Frame Ref 2:
 - Connect the reference input source to **BNC 9**.
 - Configure **JP7** for the 75ohm termination on the local reference. Refer to the section “**Card Overview**” on page 2-3 for details.

Looping Rear Module (8320AR-049)

The Looping feature is only available for the QSP-8229A when using the **8320AR-049** Rear Module in a DFR-8321 series frame. Refer to **Figure 2.6** for cabling designations.

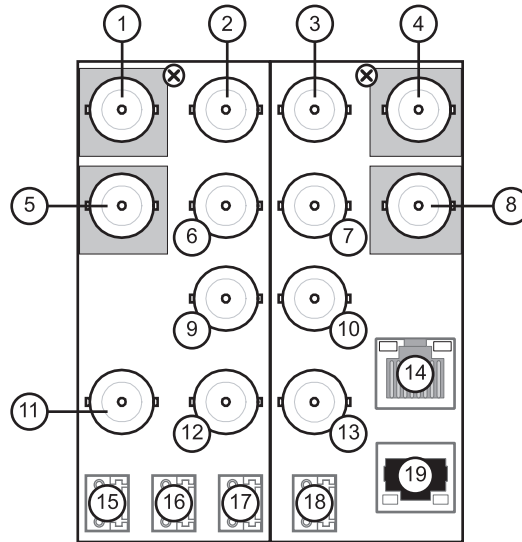

Figure 2.6 8320AR-049 Cable Connections

1) Bkgd B In BNC	6) Bkgd A Loop Out BNC	11) REF IN BNC	16) GPI 3,4 Port
2) Bkgd B Loop Out BNC	7) Bkgd D Loop Out BNC	12) OUT 3 BNC	17) GPI 5,6 Port
3) Bkgd C Loop Out BNC	8) Bkgd D In BNC	13) OUT 4 BNC	18) GPI 7,8 Port
4) Bkgd C In BNC	9) OUT 1 BNC	14) Serial COM Port	19) Ethernet 10/100 Port
5) Bkgd A In BNC	10) OUT 2 BNC	15) GPI 1,2 Port	

Cabling for Looping Rear Modules

Use the following procedure to connect video input and output cables to the Rear Module:

1. Refer to **Table 2.2** for tested cable lengths. Note that other configurations respecting the total cable lengths are possible, but are not listed here.

Table 2.2 Cabling Lengths for the 8320AR-049 Rear Module

Configuration	Input Cable Length	Loop Cable Length	Total Cable Length
270Mbps	145m	5m	150m
	5m	145m	150m
1.5Gbps	50m	4m	54m
	4m	50m	54m

2. Connect the appropriate input and output sources to the BNC connectors on the Rear Module. You do not need to terminate the Loop BNC(s) if you are not setting up a looping application.
3. To use an external reference source other than the Frame Ref 1 and Frame Ref 2:
 - Connect the reference input source to **BNC 11**.
 - Configure **JP7** for the 75ohm termination on the local reference. Refer to the section “**Card Overview**” on page 2-3 for details.

Ethernet Port Cabling

The **Ethernet 10/100** port on the Rear Module is used to connect to an ethernet network for communications, and software upgrades using the DashBoard Control System™.

This section presents a general overview of the ethernet connection process. The exact steps for connecting your card to your facility via an ethernet network depends on the network requirements of your facility.



Note — *Contact your IT Department before connecting the card to your facility network to ensure that there are no conflicts. They will provide you with an appropriate value for the IP Address, Subnet Mask, and Gateway for the card.*

Ethernet Communication Cabling

In order to properly complete this procedure, you need the following cables and equipment:

- **Ethernet Cable** — This is a standard network CAT-5 cable to connect the card to your facility network. You can use a standard straight-through ethernet cable, with no need for a crossover cable as the card includes an Auto-MDIX ethernet PHY that will switch from straight to crossover automatically as needed. Ross Video does not supply this cable.

To connect the card to an ethernet network

1. Ensure that you are running DashBoard Control System version 4.0.0 or higher before proceeding. The DashBoard Control System software and user manual are available to download from the Ross Video website.
2. Connect the card to the same subnet as your DashBoard computer or to a network that has a route to the network your DashBoard computer is on. Refer to the section “**Cabling Overview**” on page 2-8 for the **Ethernet 10/100** port location on your Rear Module.
3. Make a note of the IP Address as this information is required when configuring the communication settings for your card.
 - Network topologies vary greatly between facilities. Contact your IT Department for assistance in connecting your card to the appropriate network at your location.

For More Information...

- on setting up the ethernet communications for the card, refer to the section “**Ethernet Communication Setup**” on page 3-7.

GPI Cabling

The QSP-8229A includes eight General Purpose Input (GPI) pins to interface with external equipment. There are eight input pins labelled GPIO 1-8 on the terminal block of the Rear Module (Figure 2.4, Figure 2.5, or Figure 2.6). Ports are pre-configured to be only an input (GPI). Electrically, the ports are setup for contact closure to ground, with a 1Kohms pull-up resistor to +5V, and default to a logical high state.



Note — The default state for the GPI/O contacts is active low signalling. If a GPI cable is absent from the Rear Module, no GPI will be triggered and executed inadvertently by the card.

GPI Cable Connections

The GPI ports are available on four 3-pin WECO® connectors located on the Rear Module. Four 3-pin mating WECO® connectors are provided with the Rear Module. This section provides information for connecting GPI/Tally cables to the installed Rear Modules of your DFR-8300 series frame.

To cable the rear module for GPIs

1. Locate the GPI ports on the Rear Module. Refer to the Rear Module labelling and Refer to the section “Cabling Overview” on page 2-8 for port locations.
2. Wire the GPI ports as follows:
 - The left and right pins are the two GPI signals while the center pin is the common Ground (GND).
 - Refer to Figure 2.7, Figure 2.8, or Figure 2.9 for GPI configuration on the Rear Module.

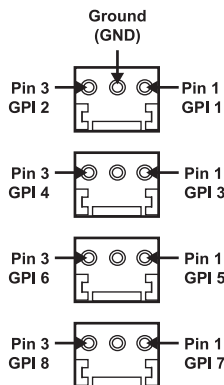

Figure 2.7 8310AR-033 GPI Connections

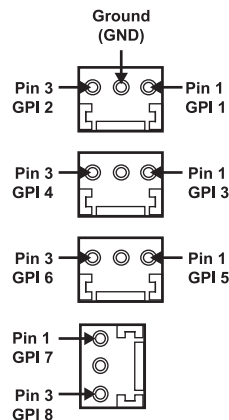

Figure 2.8 8320AR-033 GPI Connections

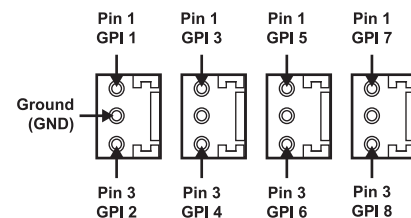

Figure 2.9 8320AR-049 GPI Connections

For More Information...

- on setting up the communications for the GPI ports, refer to the section “GPI Communication Setup” on page 3-8.

Tally Cabling

There are three methods by which on-screen tallies can be controlled with the QSP-8229A:

- **GPI** ports — Select this method to control tallies using the GPI ports on the QSP-8229A rear module.
- **Serial COM** port — Select this method to control tallies using the **Serial COM** port on the QSP-8229A rear module. The TSL UMD protocol v3.1 is used to control the tallies. If you select this method, you must also configure the QSP-8229A serial communication port to accept TSL UMD protocol messages.
- **Ethernet 10/100** port — Select this method to control tallies using the TSL UMD protocol v3.1 over a UDP or TCP connection via the **Ethernet 10/100** port on the QSP-8229A rear module. If you select this method, you must also configure the ethernet communication settings using the **Remote Control** tab.

This section outlines the physical cabling requirements for setting up on-screen tallies for the QSP-8229A. To learn more about configuring the QSP-8229A for on-screen tally communication, refer to the section “**Tally Communication Setup**” on page 3-10.



Note — *Ensure that you do not enable more than one on-screen tally communication method at any given time. Doing so may cause unpredictable on-screen tally behavior.*

GPI Port Cabling

To cable the GPI ports on the QSP-8229A rear module, refer to the section “**GPI Cabling**” on page 2-11 for details.

To set up the GPI communications, refer to the section “**Tally to GPI Setup**” on page 3-10.

Serial Port Cabling

This section outlines how to cable serial communications for the QSP-8229A. In order to properly complete this procedure, you need the following cables and equipment:

- **Serial Interface Cable** — This is a serial cable with a RJ-45 connector on one end and a connector on the other end to connect to your serial device. For the best performance, Ross Video recommends using a standard ethernet cable such as a CAT-5 or CAT-5e. **Table 2.3** includes serial cable pinout details. Ross Video does not supply this cable.

To set up serial communications for the card

1. Refer to **Table 2.3** for pinout information for your required **Serial Interface Cable**.
2. Connect and secure the RJ-45 connector of the **Serial Interface Cable** to the **Serial COM** port on the Rear Module.
3. Connect and secure the other end of the **Serial Interface Cable** to the appropriate port on your serial device. Refer to the user manual for your serial device for pinout information and the required port to use.

For More Information...

- on setting up the serial communications, refer to the section “**Tally to Serial Setup**” on page 3-11.

Serial COM Port Pin Assignment

When building cables to interface to the card **Serial COM** port, it is recommended to use CAT-5 or CAT-5e cable with the standard ethernet wiring color coding. **Table 2.3** shows the pin assignment of the **Serial COM** port located on the Rear Module.

Table 2.3 RJ-45 Pin Assignment

RJ45 Pin	RS-232	RS-422	RS-422 Null
1	n/c	Tx+	Rx+
2	Rx	Tx-	Rx-
3	Tx	Rx+	Tx+
4 ^a	+12V	+12V	+12V
5 ^a	+12V	+12V	+12V
6	n/c	Rx-	Tx-
7	GND	GND	GND
8	GND	GND	GND

Ethernet Port Cabling

If you elect to control tallies using the **Ethernet 10/100** port on the QSP-8229A rear module, refer to the section “**Ethernet Port Cabling**” on page 2-10 for cabling details.

To set up the ethernet communications, refer to the section “**Tally to Ethernet Setup**” on page 3-12.

Configuration

In This Chapter

This chapter provides instructions for configuring the QSP-8229A using the options available in the DashBoard Control System™.

The following topics are discussed:

- Selecting the Video Format and Reference Source
- Video Input and Output Configuration
- Ethernet Communication Setup
- GPI Communication Setup
- Tally Communication Setup
- Loading the Factory Defaults
- Software Upgrades



Note — *Before proceeding, ensure that you are running DashBoard software version 4.0.0 or higher. The DashBoard Control System software and user manual are available to download from the Ross Video website.*

Selecting the Video Format and Reference Source

This section provides information for configuring the video and references formats for your card.

Selecting the Video Format and Reference Source

Use the following procedure to select the video format and reference source:

1. Display the **Device** tab of the card by double-clicking its status indicator in the **Basic Tree View**.
2. Display the **Video** tab as follows:
 - From the **Device** tab, select the **Config** tab.
 - Select the **Video** tab located at the bottom of the **Config** tab.

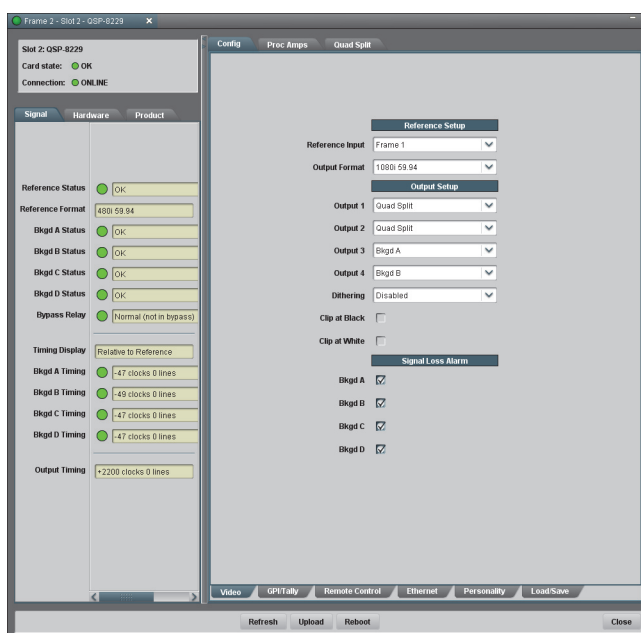

Config Tab — Video Tab

3. Select the reference source from the **Reference Input** list. Choose from the following:
 - **Frame 1** — Select this option to use the reference source connected to the **FRAME REF 1** port on the DFR-8300 series frame.
 - **Frame 2** — Select this option to use the reference source connected to the **FRAME REF 2** port on the DFR-8300 series frame.
 - **External** — Select this option to use the external reference source connected to **REF IN** on the Rear Module. Use **JP7** on the card to enable or disable a 75ohm terminator on the External Reference input. Refer to the section “**Card Overview**” on page 2-3 for information on configuring **JP7**.
4. Select the card output video format from the **Output Format** menu. Ensure that it is the same format as in the input video format.

This completes the procedure for selecting the video format and reference source.



Operating Tip — Use the **Signal** tab to monitor the Signal status, including the reference and the Background sources. Refer to the section “**Status Tabs**” on page 5-2 for more information.

Output Format Reference Compatibility

Depending on the reference format you use, the card will only be able to operate in certain formats (**Table 3.1**).

Table 3.1 Output/Reference Compatibility

Reference	Output							
	480i 59.94Hz	720p 59.94Hz	1080i 59.94Hz	576i 59.94Hz	720p 50Hz	1080i 50Hz	1080pSF 23.98Hz	1080pSF 24Hz
480i 59.94Hz	✓	✓	✓					
720p 59.94Hz		✓						
1080i 59.94Hz	✓	✓	✓					
576i 59.94Hz				✓	✓	✓		
720p 50Hz					✓			
1080i 50Hz				✓	✓	✓		
1080pSF 23.98Hz							✓	
1080pSF 24Hz								✓

Video Input and Output Configuration

Keep the following in mind when configuring your video inputs and outputs:

- You can configure any of the four outputs independently to display the Quad Split or any of the backgrounds. Note that when a Bkgd source is fed through full screen, the ancillary data will also pass.
- The Quad sources can be any of the four Background sources, or an internally generated black.
- The Quad outputs are configured directly from the **Quad Split** tab.
- Each output has a Proc Amp that can adjust parameters such as the black offset and gain.
- All of the outputs can be enabled to add dither, clip to SMPTE black or allow super-black, or clip to SMPTE white or allow super-white.

Configuring the Video Outputs

Use the following procedure to configure your video outputs on the card:

1. Display the **Device** tab of the card by double-clicking its status indicator in the **Basic Tree View**.
2. Display the **Video** tab as follows:
 - From the **Device** tab, select the **Config** tab.
 - Select the **Video** tab located at the bottom of the **Config** tab.
3. From the **Output Setup** area, locate the Output BNC you want to configure.
4. Choose an output to configure as follows:
 - **Output 1** — Select this field to configure the source on Output 1.
 - **Output 2** — Select this field to configure the source on Output 2.
 - **Output 3** — Select this field to configure the source on Output 3.
 - **Output 4** — Select this field to configure the source on Output 4.
5. Select the output that you want to assign to the selected Output BNC from the corresponding **Output** field. You can choose between the following:
 - **Quad Split** — Select this option to assign the Quad Split to the selected output.
 - **Bkgd A** — Select this option to assign Bkgd A to the selected output.
 - **Bkgd B** — Select this option to assign Bkgd B to the selected output.
 - **Bkgd C** — Select this option to assign Bkgd C to the selected output.
 - **Bkgd D** — Select this option to assign Bkgd D to the selected output.
6. From the **Dithering** field, select the type of dithering you want to apply to all outputs. You can choose between the following:
 - **Disabled** — Select this option to disable the Dithering feature.
 - **Enabled low** — Select this option to enable 2 bit dithering.
 - **Enabled medium** — Select this option to enable 3 bit dithering.
 - **Enabled high** — Select this option to enable 4 bit dithering.
7. Enable the Clip White or Clip Black feature as follows:
 - **Clip at Black** — Select this box to enable the card to clip to SMPTE black on all outputs. An unchecked box allows super-black.

- **Clip at White** — Select this box to enable the card to clip to SMPTE white on all outputs. An unchecked box allows super-white.

This completes the procedure for configuring your outputs on the card.

Configuring the Input Signal Timing Display

The **Timing Display** feature enables you to configure how the input signal timing is reported by DashBoard. This information is displayed in the **Bkgd A, B, C, and D Timing** fields of the **Signal** tab in the number of clocks and lines. Negative values indicate the input signal timing is earlier than the reference. Positive values indicate the input signal timing is later than the reference. Note that there are 4400 clocks per line when using the 1080i 59.94Hz format.

Use the following procedure to configure the input signal timing for your QSP-8229A:

1. Display the **Device** tab of the card by double-clicking its status indicator in the **Basic Tree View**.
2. Display the **Personality** tab as follows:
 - From the **Device** tab, select the **Config** tab.
 - Select the **Personality** tab located at the bottom of the **Config** tab.
3. Configure how the signal timing by selecting one of the following options from the **Timing Display** menu:
 - **Relative to Reference** — Select this option to display the timing offset values of the SDI inputs and output relative to the selected analog reference as follows:
 - › A negative offset value indicates that the SDI signal is earlier than the analog reference.
 - › A positive value indicates that the SDI signal is later than the analog reference.
 - **Input to Output** — Select this option to display the timing offset values of the SDI BKGD inputs relative to the SDI output of the card as follows:
 - › A negative offset value indicates that the SDI BKGD input signal is earlier than the SDI OUT signal.
 - › A positive value indicates that the SDI BKGD input signal is later than the SDI OUT signal.

This completes the procedure for configuring the input signal timing for your QSP-8229A.

Signal Loss Alarm Setup

The **Signal Loss Alarm** feature enables DashBoard to display status alarms when a loss of signal is experienced on the Background input sources. The alarm information displays in the **Signal** tab of DashBoard and on the card-edge LEDs. For more information on the status LEDs, refer to the section “**Card-edge LEDs**” on page 2-4.

Use the following procedure to set up the Signal Loss Alarm feature:

1. Display the **Device** tab of the card by double-clicking its status indicator in the **Basic Tree View**.
2. Display the **Video** tab as follows:
 - From the **Device** tab, select the **Config** tab.
 - Select the **Video** tab located at the bottom of the **Config** tab.
3. Enable or disable the alarms by selecting or deselecting the required boxes in the **Signal Loss Alarm** area as follows:

- **Bkgd A** — Select this box to enable DashBoard to report the status of the Background A input source.
- **Bkgd B** — Select this box to enable DashBoard to report the status of the Background B input source.
- **Bkgd C** — Select this box to enable DashBoard to report the status of the Background C input source.
- **Bkgd D** — Selecting this box enables DashBoard to report the status of the Background D input source.

This completes the procedure for setting up the Signal Loss Alarm.

Ethernet Communication Setup

To enable the card to perform software upgrades, the card must be configured with valid ethernet settings for the **Ethernet 10/100** port on the Rear Module of the card. The settings can be specified manually (**Static**) or may be obtained automatically from a server on your network (**DHCP**).

Use the following procedure to set up ethernet communications for the card:

1. Display the **Device** tab of the card by double-clicking its status indicator in the **Basic Tree View**.
2. Display the **Ethernet** tab as follows:
 - From the **Device** tab, select the **Config** tab.
 - Select the **Ethernet** tab located at the bottom of the **Config** tab.

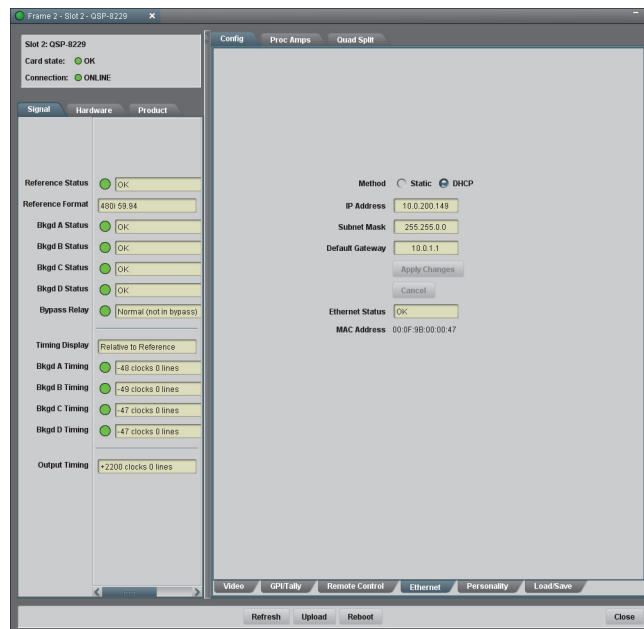

Config Tab — Ethernet Tab

3. To obtain network settings automatically:
 - Select **DHCP** from the **Method** drop-down list.
 - To save the new settings, click **Apply Changes**. Note that clicking **Cancel** will revert to the previous settings.
4. To manually configure the ethernet settings:
 - Select **Static** from the **Method** drop-down list.
 - Enter the **IP Address**, **Subnet Mask**, and **Default Gateway** settings for the card.
 - To save the new settings, click **Apply Changes**. Note that clicking **Cancel** will revert to the previous settings.

This completes the procedure for setting up ethernet communications for the card.



Note — The **Ethernet Status** field in the **Ethernet** tab displays the current status of your connection. Refer to **Table 5.7** for a list of the messages.

GPI Communication Setup

This section explains how to configure communications for GPIs on the card using the menus and options available in DashBoard.

GPI Overview

When configured as a GPI, a port behaves as an input, and can be used to trigger actions such as switching between the Quad Split display or full-screen BKGD input display. A push-button switch, or an ON-OFF switch, may be directly connected between the port and the adjacent ground pin. Minimum pulse duration is 1ms, anything shorter will be filtered out.

GPI Communication Setup

You can configure the GPI to control the display configuration. Each output can be set to display the Quad Split, a Bkgd source, or to cycle through the sources each time the specific GPI/Tally is triggered.



Note — Each GPI should be set to a different function. Setting more than one GPI to the same function can cause unexpected behavior. Multiple GPIs can be set to None at the same time.

Use the following procedure to configure remote control for GPIs:

1. Display the **Device** tab of the card by double-clicking its status indicator in the **Basic Tree View**.
2. Display the **GPI/Tally** tab as follows:
 - From the **Device** tab, select the **Config** tab.
 - Select the **GPI/Tally** tab located at the bottom of the **Config** tab.

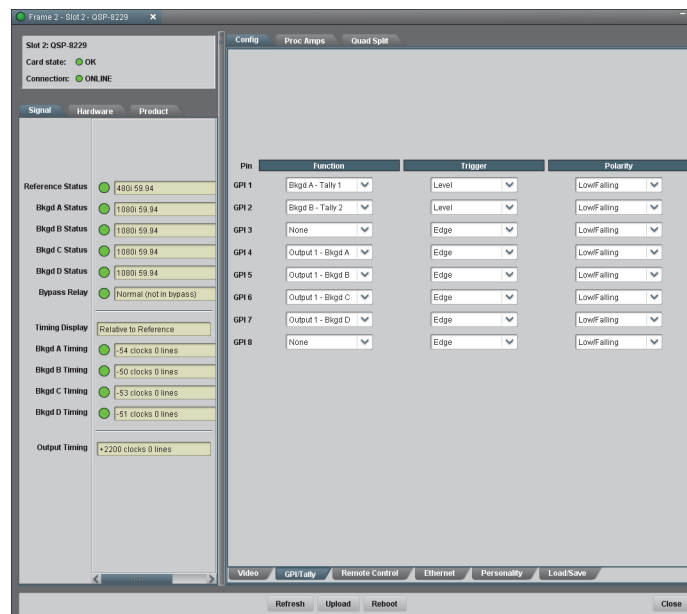

Config Tab — GPI/Tally Tab

3. Assign a transition event to a GPI /Tally by selecting the function from the **Function** drop-down list to the required GPI/Tally. Choose from the following:
 - **None** — Select this option to not assign a function to the selected GPI/Tally. The Trigger and Polarity settings are ignored. This is the default setting.
 - **Output xx - Quad** — Selecting this option causes the specified output, where **xx** represents the output, to display the Quad Split when the GPI is triggered.
 - **Output xx - Bkgd #** — Selecting this option causes the specified output, where **xx** represents the output, to display the specified full-screen input when the GPI is triggered.
 - **Output xx - Cycle** — Selecting this option causes the specified output, where **xx** represents the output, to cycle through the Quad Split and full-screen inputs when the GPI is triggered.
 - **yy Quad - Black** — Selecting this option causes the specified quadrant, where **yy** represents the quadrant (UL, UR, LL, and LR), to show black when the GPI is triggered.
 - **yy Quad - Bkgd #** — Selecting this option causes the specified quadrant, where **yy** represents the quadrant, to show the specified Bkgd source when the GPI is triggered.
 - **yy Quad - Cycle** — Selecting this option causes the specified quadrant, where **yy** represents the quadrant, to cycle through Black and the four inputs when the GPI is triggered.
 - **Bkgd # - Tally x** — Selecting this option causes the GPI to control the specified tally, where **x** represents the tally number, associated with the specified Bkgd input. Refer to the section “**Tally to GPI Setup**” on page 3-10 for details.
4. Select a trigger for the GPI from the **Trigger** column. Choose from the following:
 - **Edge** — Select this option to configure the card to perform the **Function** on either the Rising or Falling Edge of the GPI signal as determined by the **Polarity** setting.
 - **Level** — Select this option to have the GPI action controlled by a static voltage level. The card performs the **Function** when the GPI state is either High or Low as determined by the **Polarity** set in step 5. The action triggered by the GPI input will remain in that state until the GPI level changes. Select this option when using a GPI to control a tally.
5. Select a polarity for the GPI from the **Polarity** column. Choose from the following:
 - **High/Rising** — Select this option to have the GPI triggered on a static High level, or on a Low-to-High pulse.
 - **Low/Falling** — Select this option to have the GPI triggered on a static Low level or on a High-to-Low pulse. This is the default setting.

This completes the procedure for configuring remote control for GPIs.

Tally Communication Setup

With the on-screen tally display feature, each quadrant of the QSP-8229A supports two tallies (for Program and Preview) with selectable position and color. Tallies can be shown as small circles, or can be drawn into the border surrounding each quadrant. Note that this feature is not enabled by default. This section explains how to enable and configure communications for on-screen tallies using the menus and options available in DashBoard. There are three steps:

1. **Enable the Tally UMD Feature** — The tally on-screen display feature is disabled by default. You must change the **Tally Position** menu item from the default value of **None** to one of the other three options.
2. **Set up Communications** — You must configure the correct type of communication between the device and the QSP-8229A based on the cabling performed in the section “**Tally Cabling**” on page 2-12.
3. **Set up the Tally On-Screen Labels** — Once communications are set up, you can assign a channel for each of the four card inputs, specify how the label information from the on-screen tally device will be processed, select the color of each on-screen tally, and determine the position of the on-screen tallies. Refer to the section “**Set up the Tally On-Screen Labels**” on page 3-12 for details.

Enable the Tally UMD Feature

Use the following procedure to enable the on-screen tally label display:

1. Display the **Device** tab of the QSP-8229A by double-clicking its status indicator in the **Basic Tree View**.
2. Display the **Tally/Border** tab as follows:
 - From the **Device** tab, select the **Quad Split** tab.
 - Select the **Tally/Border** tab located at the bottom of the **Quad Split** tab.
3. Assign the tally on-screen display positions by selecting one of the **Tally Position** options from the **Tally Control** area. Refer to the section “**Tally/Border Tab**” on page 5-11 for a list of options.

Set up Communications

This section provides instructions on how to set up the communications between the QSP-8229A and the on-screen tally device. The method for setting up communications depends on how the device is connected to your QSP-8229A.

Tally to GPI Setup



Note — *Each GPI port should be set to a different function. Setting more than one GPI port to the same function can cause unexpected behavior. Multiple GPI ports can be set to None at the same time.*

This section outlines how to set up communications between your on-screen tally device and the QSP-8229A when using GPIs.

Use the following procedure to configure remote GPI control for on-screen tallies:

1. Display the **Device** tab of the QSP-8229A by double-clicking its status indicator in the **Basic Tree View**.
2. Display the **GPI/Tally** tab as follows:
 - From the **Device** tab, select the **Config** tab.
 - Select the **GPI/Tally** tab located at the bottom of the **Config** tab.
3. Assign an event to an on-screen tally by selecting the function from the **Function** drop-down list to the required tally. Choose from the following:
 - **Bkgd # - Tally 1** — Select this option to have the GPI control the first on-screen tally associated with the specified input.
 - **Bkgd # - Tally 2** — Select this option to have the GPI control the second on-screen tally associated with the specified input.
4. Set the **Trigger** to **Level**.

This completes the procedure for configuring remote control for on-screen tallies via the GPI ports.

Tally to Serial Setup

The **Serial Port** area of the **Remote Control** tab includes options for configuring serial communications, using the TSL UMD v3.1 protocol, between the QSP-8229A and the serial device connected to the **Serial COM** port on the card rear module. This section outlines how to set up serial communications between your on-screen tally device and the QSP-8229A.

Use the following procedure to configure remote serial control for on-screen tallies:

1. Display the **Device** tab of the QSP-8229A by double-clicking its status indicator in the **Basic Tree View**.
2. Display the **Remote Control** tab as follows:
 - From the **Device** tab, select the **Config** tab.
 - Select the **Remote Control** tab located at the bottom of the **Config** tab.

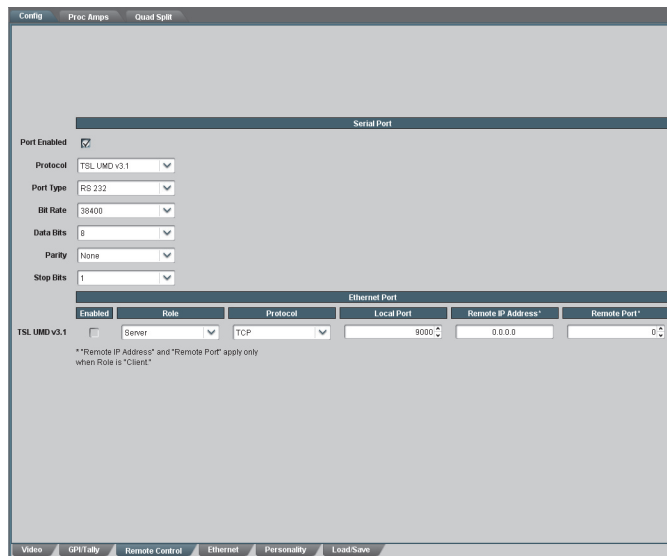

Config Tab — Remote Control Tab

3. Select **TSL UMD v3.1** from the **Protocol** menu.

4. Configure the **Port Type**, **Bit Rate**, **Data Bits**, **Parity**, and **Stop Bits** as required by the serial on-screen tally device connected to the QSP-8229A rear module.
5. Select the **Port Enabled** box to enable serial on-screen tally communication from the **Serial COM** port on the QSP-8229A rear module.

This completes the procedure for configuring serial control for on-screen tallies.

Tally to Ethernet Setup

The **Ethernet Protocol** area of the **Remote Control** tab includes options for configuring communications for the **Ethernet 10/100** port on the QSP-8229A rear module. This section outlines how to set up ethernet communications between your on-screen tally device and the QSP-8229A.

Use the following procedure to configure ethernet communications to an on-screen tally device:

1. Display the **Device** tab of the QSP-8229A by double-clicking its status indicator in the **Basic Tree View**.
2. Display the **Remote Control** tab as follows:
 - From the **Device** tab, select the **Config** tab.
 - Select the **Remote Control** tab located at the bottom of the **Config** tab.
3. Specify the type of ethernet service for the QSP-8229A from the **Role** menu. Choose from the following:
 - **Server** — Select this option to enable the QSP-8229A to function as a host, or socket listener, on the network. This is the recommended setting.
 - **Client** — Select this option to configure the QSP-8229A to function as a service requester that initiates communications with a server.
4. Select the ethernet protocol used by your on-screen tally device from the **Protocol** menu. Choose from the following:
 - **TCP** — Select this option if your on-screen tally device uses the Transmission Control Protocol (TCP) for ethernet communications.
 - **UDP** — Select this option if your on-screen tally device uses the User Data Protocol (UDP) for ethernet communications.
5. Enter the port number for your on-screen tally device in the **Local Port** field. When the **Role** is set to **Server**, the QSP-8229A will listen on the specified port for incoming connections.
6. If you selected **Client** in step 3., specify the Remote IP Address and Remote Port number of the remote device to which the QSP-8229A should connect. For example, if you use an external ethernet-to-serial port expander, you would enter the IP address and port number of the serial port expander here.
7. Select the **TSL UMD v3.1** box to enable ethernet communication from the **Ethernet 10/100** port on the QSP-8229A rear module to the tally device.

This completes the procedure for configure ethernet communications to an on-screen tally device.

Set up the Tally On-Screen Labels

The **Quad Split** tab includes a tab for each card input that enables you to assign a channel for each of the four card inputs, specify how the label information from the on-screen tally device will be processed, select the color (RGB format) of the border, and determine the position of the on-screen tallies. By default, the QSP-8229A displays the static label text as defined in the **Bkgd** field in the Quad Split sub-tab for a source.

To set the border color and size:

1. Display the **Device** tab of the QSP-8229A by double-clicking its status indicator in the **Basic Tree View**.
2. Display the **Tally/Border** tab as follows:
 - From the **Device** tab, select the **Quad Split** tab.
 - Select the **Tally/Border** tab located at the bottom of the **Quad Split** tab.
3. To set the border size for all sources, use the **Border Size** slider to adjust the thickness of the border in pixel units. As you adjust the thickness of the border, it expands inwards from the edge of the quadrant. A value of 0 removes the border.
4. To apply the same border color to all sources, select a specific color from the **Border Color** menu located in the **Border Control** area.
5. To apply a unique border color for a source:
 - Select **Color** from the **Border Color** menu.
 - Select the sub-tab for the source you wish to configure a unique border color for.
 - Use the **Red**, **Green**, **Blue**, and **Transparent** sliders to configure the border color for that source.

To configure an input label content:

1. From the **Quad Split** tab, select the sub-tab for the card input you wish to configure.
2. If required, update the on-screen QSP-8229A static label for the input by typing a new name in the **Bkgd** field located at the top of the **Label** area.



Operating Tip — *When using long strings of text in labels, adding a space or hyphen to the QSP-8229A static label helps ensure proper spacing of the text when displayed on-screen. For example, if you are prepending the dynamic label information, add a hyphen at the beginning of the QSP-8229A static label.*

3. If the TSL UMD protocol is enabled, the QSP-8229A can add the dynamic label provided by the protocol. Choose one of the following from the **TSL UMD** menu:
 - **Ignore** — Select this option to ignore the dynamic label information from the on-screen tally device and display only the QSP-8229A static label (as defined in step 2.). The TSL UMD protocol only controls the tally indicators.
 - **Append** — Select this option to display the dynamic label information *after* the QSP-8229A static label (as defined in step 2.). This is the default setting.
 - **Prepend** — Select this option to display the dynamic label information from the on-screen tally device *before* the QSP-8229A static label (as defined in step 2.).
 - **Replace** — Select this option to display only the dynamic label information and ignore the QSP-8229A static label.
4. Assign a channel for the card input by entering the source Display Address using the **TSL Address** slider.
5. Configure the area behind the tally source label for the specified card input as follows:
 - Use the sliders in the **Color** area to configure the color of the label area.
 - Use the **Transparency** slider to configure the appearance of the label area from opaque (0), through transparent, to fully off (100).

Loading the Factory Defaults

If required, the card menu parameters can be reset to the factory default values using the option available in the **Load/Save** tab.



Note — *Ethernet settings, reference input selection, and the output formats are not reset using this method.*

To reset the card to the factory default configuration in Dashboard

1. Display the **Device** tab of the card by double-clicking its status indicator in the **Basic Tree View**.
2. Display the **Load/Save** tab as follows:
 - From the **Device** tab, select the **Config** tab.
 - Select the **Load/Save** tab located at the bottom of the **Config** tab.
3. From the **Global Settings** area, click **Load Factory Defaults** to display the **Confirm** dialog.
4. Press **Yes** to load the factory default values for all menu parameters, or **No** to cancel the load and close the dialog.

Software Upgrades

The card can be upgraded in the field using the **Ethernet 10/100** port on the Rear Module and using the options available in DashBoard. Refer to the section “**Ethernet Communication Setup**” on page 3-7 for setting up ethernet communications.



Note — *This procedure assumes that you are running DashBoard version 4.0.0 or higher.*

To upgrade the software on a card

1. Contact Ross Technical Support for the latest software version file.
2. Display the **Device** tab of the card by double-clicking its status indicator in the **Basic Tree View**.
3. From the **Device** tab, click **Upload** to display the **Select file Upload** dialog.
4. Navigate to the ***.bin** file you wish to upload.
5. Click **Open**.
6. If you are upgrading a single card, click **Finish** to start the upgrade. Proceed to step 8.
7. If you are upgrading multiple cards:
 - Click **Next >** to display the **Select Destination** menu. This menu provides a list of the compatible cards based on the card selected in step 2.
 - Specify the card(s) to upload the file to by selecting the check box(es) for the cards you wish to upload the file to.
 - Verify that the card(s) you wish to upload the file to. The **Error/Warning** fields indicate any errors, such as incompatible software or card type mismatch.
 - Click **Finish**.
8. Monitor the upgrade.
 - A **Upload Status** dialog enables you to monitor the upgrade process.
 - Note that if the ethernet connection is invalid, such as the ethernet cable is unplugged from the card rear module, the user is prompted to reboot the card when the upgrade is complete. If multiple cards are being upgraded, the user should wait for all to complete, before rebooting them.
 - The card is temporarily taken offline.
 - The reboot process is complete once the status indicators for the **Card State** and **Connection** return to their previous status.



Operating Tip — *If you are running DashBoard v2.3.0 or lower, you must click **Reboot** in the **Device** tab to complete the upgrade process.*

Troubleshooting

If you encounter problems when upgrading your card software, verify the following:

- Your network settings on the card are valid. Refer to **Table 5.7** for a list of settings.
- Ethernet cable is properly connected if you are uploading the file via a network connection.
- The file you are attempting to load is a ***.bin** file that is for the card you are upgrading.

Operation

In This Chapter

This chapter provides a summary of the operational features, such as Proc Amp controls and assigning input sources to the Quad Split.

The following topics are discussed:

- Adjusting the Proc Amp Controls
- Configuring the Quad Split Sources
- Notes on Timing



Note — *Before proceeding, ensure that you are running DashBoard software version 4.0.0 or higher. The DashBoard Control System software and user manual are available for download from the Ross Video website.*

Adjusting the Proc Amp Controls

Each output on the card has a Proc Amp that can adjust the black offset, the video gain, the chroma gain and the CB gain. This section briefly outlines how to adjust the options available in the **Proc Amp** tab.

To adjust an output using a Proc Amp

1. Display the **Device** tab of the card by double-clicking its status indicator in the **Basic Tree View**.
2. Select an output signal to adjust as follows:
 - Select the **Proc Amps** tab.
 - Select the **Output** tab for the output signal you want to adjust. The **Output** tabs are located at the bottom of the **Proc Amps** tab.

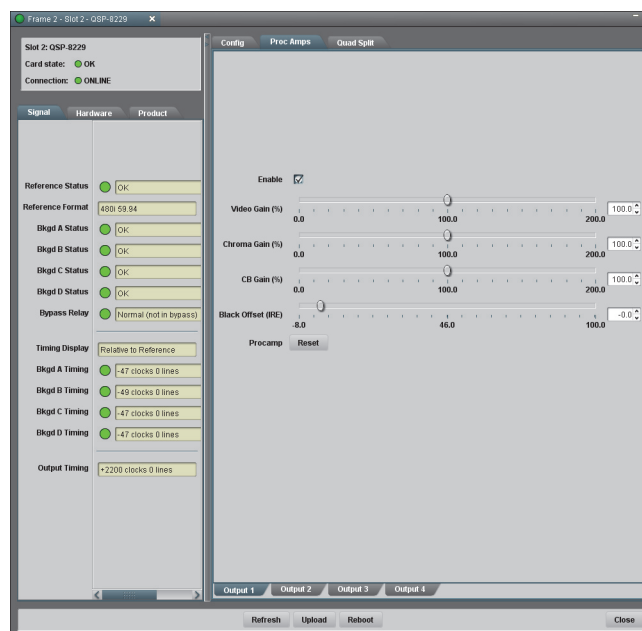

Proc Amps Tab — Out 1 - Program Tab

3. Select the **Enable** box to ensure the color adjustments are applied. The **Enable** box must be selected in order for any color correction to take effect on the selected output.
4. Adjust the **Video Gain** of the card video outputs as follows:
 - Use the **Video Gain** slider to adjust the amount of Video Gain you want to apply. Increasing overall gain causes an increase in contrast while also making colors more saturated and vivid. Decreasing overall gain causes a decrease in contrast while de-saturating colors.
5. Adjust the **Chroma Gain** of the card video outputs as follows:
 - Use the **Chroma Gain** slider to adjust the chrominance video signal components (Cr and Cb) simultaneously. Increasing the chroma gain value causes the video signal colors to become increasingly saturated and more vivid. Decreasing the chroma gain value de-saturates color from the video signal until it is black and white.
6. Adjust the **CB Gain** of the card video outputs as follows:

- Use the **CB Gain** slider to adjust the Cb component of the chrominance video signal. Increasing the Cb Gain value causes the video signal colors to become increasingly saturated with blue. Decreasing the Cb Gain value desaturates blue from the video signal.
7. Adjust the **Black Offset** of the card video outputs as follows:
- Use the **Black Offset** slider to adjust the Black Offset you want to apply. Increasing the Black Offset value causes a lightening effect. Decreasing the Black Offset value causes a darkening effect.



Operating Tip — *To reset the Proc Amp settings to the default values, click **Reset** and then **Yes** in the **Confirm** dialog box.*

Configuring the Quad Split Sources

This section briefly describes how to set up your Quad Split sources using the **Quad Split** tab in Dashboard. From the **Quad Split** tab, you can assign any input to any quadrant and add a text label to display at the bottom of the applicable quadrant. All active video content will be visible, including the 480i Line 21 content. Note that when a loss of input in a quadrant occurs, the QSP-8229A fills that quadrant with a blue pattern.



Note — The ancillary data (HANC and VANC) of the Quad Split is empty but filled with valid black.

Assigning Sources to the Quad Split

Use the following procedure to assign sources to a Quad Split quadrant:

1. Display the **Device** tab of the card by double-clicking its status indicator in the **Basic Tree View**.
2. From the **Device** tab, select the **Quad Split** tab.

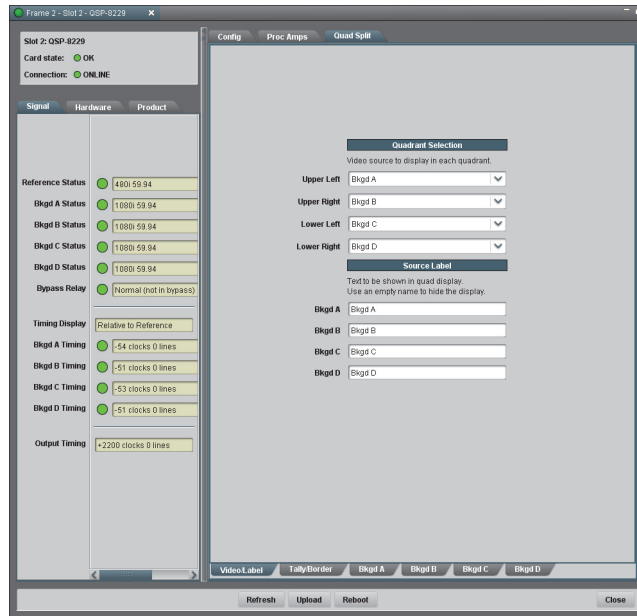

Quad Split — Video/Label Tab

3. Select the **Video/Label** tab.
4. Select the quadrant you wish to configure.
5. Assign a video source to the specific quadrant by selecting an option from the corresponding drop-down menu. Choose from the following:
 - **Black** — Select this option to assign black to the specific quadrant.
 - **Bkgd A** — Select this option to assign the Bkgd A input to the specific quadrant.
 - **Bkgd B** — Select this option to assign the Bkgd B input to the specific quadrant.
 - **Bkgd C** — Select this option to assign the Bkgd C input to the specific quadrant.
 - **Bkgd D** — Select this option to assign the Bkgd D input to the specific quadrant.
6. To apply a text label to the quadrant:
 - Locate the **Source Label** area of the **Quad Split** tab.

- Enter a text label in the applicable text box for the input source.
- Press **Enter** on your keyboard to apply the new text.

Applying a Border

The Border feature allows you to set the color (RGB format), transparency, and overall thickness of the border that is applied to the specified source. Borders are created from the outside edge of the quadrant and expand inward. The border is applicable to all quadrants.

To adjust the border for all quadrants

1. Display the **Device** tab of the card by double-clicking its status indicator in the **Basic Tree View**.
2. From the **Device** tab, select the **Quad Split** tab.

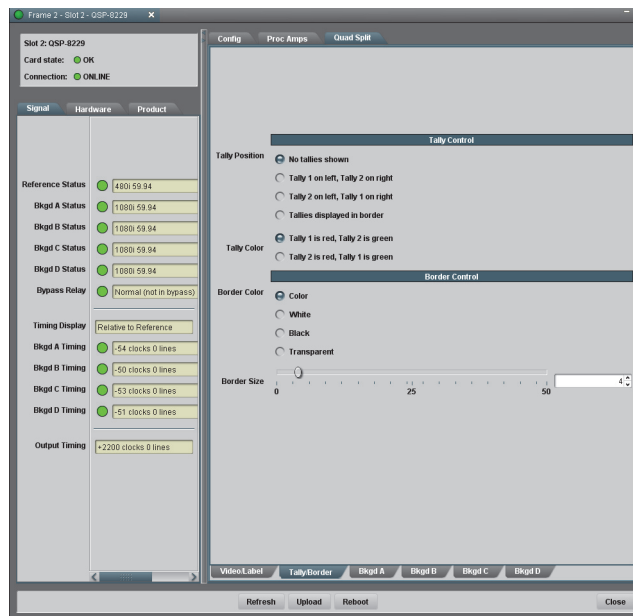

Quad Split — Tally/Border Tab

3. Select the **Tally/Border** tab.
4. Select a **Border Color** option from the **Border Control** area. Note that if you select **Color**, you can apply a different color to each source border as outlined in the section “**To set the border color and size:**” on page 3-13.
5. Use the **Border Size** slider to adjust the thickness of the border in pixel units. Notice that as you adjust the thickness of the border, it expands inwards from the edge of the quadrant. A value of 0 removes the border.

Notes on Timing

This section provides additional information on the timing features of the QSP-8229A:

- On the current software release, SDI output timing of the card is currently fixed at 0.5 line after the selected analog reference. For example, when using a 1080i output format, the **Output Timing** field in the **Signal** tab will be +2200 clocks because the output timing measurement is relative to the selected analog reference.
- Each video input has a line sync that can support a full line of SD or HD video including horizontal blanking.
- When showing full screen BKGD inputs (no Quad Split), line syncs are used and all BKGD video inputs must be timed within +/- 0.5 line offset from the selected analog reference. Exceeding this tolerance will result in shifting the full screen output display by one or several lines.
- When using Quad Split, frame syncs are used and the BKGD video inputs do not need to be timed to the selected analog reference. The video scaling requires a frame store operation and the BKGD inputs will be delayed by up to one frame before it is displayed in the Quad Split quadrants.
- All of the video outputs must be the same video format as the video inputs. If the formats do not match, the card reports an error in the Dashboard **Signal Status** area and on the card-edge LEDs.
- When using Quad Split, inputs that are mis-timed will be aligned to the next frame boundary.
- By default, Dashboard displays output timing relative to the reference. Signal timing is reported in Clocks and Lines.
- Use the Timing Display option in the **Personality** tab to configure how Dashboard displays the input signal timing. You can choose to report the timing as relative to the output or relative to the reference.

Appendix A. DashBoard Menus

In This Appendix

The DashBoard Control System enables you to monitor and control openGear frames and cards from a computer. DashBoard communicates with cards in the openGear DFR-8300 series frames through a MFC-8300 Series Network Controller Card. This controller card is required in order to use DashBoard to monitor the QSP-8229A. Refer to the *MFC-8300 Series User Manual* for details.

This appendix briefly summarizes the menus, items, and parameters available from the DashBoard Control System™ for the QSP-8229A. Default values are noted with an asterisk (*).

The following topics are discussed:

- Status Tabs
- Configuration Tabs
- Proc Amps Tab
- Quad Split Tabs



Note — *Before proceeding, ensure that you are running DashBoard software version 4.0.0 or higher. The DashBoard Control System software and user manual are available to download from the Ross Video website (www.opengear.tv).*

Status Tabs

The following table summarizes the read-only information displayed in the **Status** tabs. The fields in the **Signal** tab vary in severity from green (valid), yellow (caution), to red (alarm). DashBoard reports the most severe alarm for a single field. Alarm colors are noted within the tables as text set in brackets next to the menu parameter name.

Signal Tab

Table 5.1 outlines the read-only information displayed in the **Signal** tab for the QSP-8229A.

Table 5.1 Signal Tab Items

Tab Title	Item	Parameters	Description
Signal (Read-only)	Reference Status	OK (Green)	Valid reference signal
		No reference (Red)	No signal detected on selected reference input
		Reference Unlocked (Red)	Signal detected, but not locked (or lock lost)
		Invalid Reference (Red)	Signal detected, but incompatible with the current video mode
	Bkgd # Status	OK (Green)	Normal operation
		Alarm Suppressed (Green)	An alarm condition exists but is silenced
		Incompatible (Yellow)	The input video format is incompatible with the output format however the frame rates match
		Unsupported (Red)	The input format is compatible with the output format however the frame rates differ
		No signal (Red)	No signal present on the specified input
	Bypass Relay	Normal (not in bypass) (Green)	Video is being routed through the card; Quad Split may be active
		Active (in bypass) (Red)	BKGD A bypasses the card and is looped passively on Output 1 through the relay
	Timing Display	Relative to Reference	The BKGD Timing fields display the timing values relative to the selected analog reference
		Input to Output	The BKGD Timing fields display the timing values relative to the SDI output of the card
	Bkgd # Timing	## clocks ## lines	Indicates the timing of the specified input signal relative to the reference signal or relative to the output as specified in the Timing Display feature where 1 clock is: <ul style="list-style-type: none"> • 1 period of 27MHz (SD), or • 1 period of 148.x MHz (HD)
		(Green)	Indicates that the timing is within the specified range for the card
		(Yellow)	Indicates that the card is operating outside the specified line sync range. You may encounter vertical shifts and/or missing ancillary data when viewing at full-screen.

Table 5.1 Signal Tab Items

Tab Title	Item	Parameters	Description
Signal (Read-only)	Bkgd # Timing	(Gray)	Indicates the absence of the specified input signal. Verify that the cable is properly secured to the rear module.
	Output Timing	## clocks ## lines	Indicates the timing of the output signals relative to the reference

Hardware Tab

Table 5.2 outlines the read-only information displayed in the **Hardware** tab for the QSP-8229A.

Table 5.2 Hardware Tab Items

Tab Title	Item	Parameters	Description
Hardware (Read-only)	HW Status	OK (Green)	Normal operation; no hardware errors and the correct rear module is installed
		Incomp I/O module (Red)	Card is connected to the wrong rear module
		Alarm suppressed (Green)	Rear module is incompatible and the Incompat Rear Module alarm is disabled
	Voltage (V)	#	Supply Voltage, in Volts
	Current (mA)	#	Current consumption of card in milliAmperes
	Power (W)	#	Power consumption of card in Watts
	FPGA Temp	##C ^a / ##F	FPGA core temperature
	FPGA Fan ^b	# RPM	Indicates the card fan speed
	CPU Usage	x.xx / y.yy / z.zz ^c	CPU Load average
	RAM Available	## / ## MB	Memory Used / Total Memory
	CF Card Status	#.## of 2.0 GB used	Displays the amount of memory used on the CompactFlash card
		Missing	CompactFlash card is not present
		Unreadable	An error has occurred, such as incompatible CompactFlash card, or an error reading the card
	Playout RAM	a/b/c/d	Displays RAM memory usage where: <ul style="list-style-type: none"> • a represents the memory in use • b represents the memory cache from previously loaded files • c represents the memory dedicated to the frame sync buffers and related functions. Note that this memory is unavailable for images and animations. • d represents the total playout memory

- A warning is displayed in DashBoard when the FPGA Core Temperature reaches 85°C. If the temperature reaches 110°C, the card will automatically shut down to avoid permanent damage and will have to be reset, rebooted, or power cycled to resume normal operation.
- This field is displayed for QSP-8229A models (Board Rev 3 or higher).
- The CPU Load average is displayed in the following format where x.xx represents in the last minute, y.yy represents the last five minutes and z.zz is the last fifteen minutes.

Product Tab

Table 5.2 outlines the read-only information displayed in the **Hardware** tab for the QSP-8229A.

Table 5.3 Product Tab Items

Tab Title	Item	Parameters	Description
Product (Read-only)	Product	QSP-8229A	
	Supplier	Ross Video Ltd.	
	Board Rev	##	Indicates the board version of your card
	Serial Number	#####	Indicates the serial number of your card
	Rear Module	#	Indicates the type of Rear Module in the slot
	Software Rev	## build ###	Indicates the software and build versions
	Firmware Rev	##.##	Indicates the FPGA version number

Configuration Tabs

This section briefly summarizes the options and tabs available in the **Config** tab.

Video Configuration

Table 5.4 summarizes the **Video** tab options available in DashBoard.

Table 5.4 Video Tab Options

Menu	Item	Parameters	Description	
Reference Setup	Reference Input	Frame 1*	The card is using Frame Reference 1	
		Frame 2	The card is using Frame Reference 2	
		External	The card is using the reference input on: <ul style="list-style-type: none"> • BNC 9 (8310AR-033, 8320AR-033); or • BNC 11 (8320AR-049) 	
	Output Format	#	Specifies the format of the output signal of the card	
Output Setup	Output 1	Quad Split*	Output 1 displays the Quad Split as configured using the options in the Quad Split tab	
		Bkgd A	Output 1 displays the Bkgd A source	
		Bkgd B	Output 1 displays the Bkgd B source	
		Bkgd C	Output 1 displays the Bkgd C source	
		Bkgd D	Output 1 displays the Bkgd D source	
	Output 2	Same parameters as above. The default setting is Quad Split.		
	Output 3	Same parameters as above. The default setting is Bkgd A.		
	Output 4	Same parameters as above. The default setting is Bkgd B.		
	Dithering	Disabled*	Dithering is disabled	
		Enabled - low	Dithering is enabled and set to 2bits	
		Enabled - medium	Dithering is enabled and set to 3bits	
		Enabled - high	Dithering is enabled and set to 4bits	
	Clip at Black	Selected	SuperBlack is clipped on all outputs	
		Cleared*	SuperBlack is not clipped	
	Clip at White	Selected	SuperWhite is clipped on all outputs	
		Cleared*	SuperWhite is not clipped	
Signal Loss Alarm	Bkgd #	Selected*	An alarm is triggered when a missing or an invalid signal is detected on the specified input	
		Cleared	The alarm is suppressed when a missing or an invalid signal is detected on the specified input	

GPI/Tally Configuration

The menu items available in the **GPI/Tally Setup** tab enable you to configure the functions and polarity of each GPI connected to the QSP-8229A.

Table 5.5 GPI/Tally Setup Menu Items

Menu	Item	Parameter	Description
GPI #	Function	None*	The port is not configured and the GPI has no effect
		Output # - Quad	When triggered, the specified output displays the Quad Split
		Output # - Bkgd #	When triggered, the specified output displays the specified Bkgd source at full-screen
		Output # - Cycle	On each trigger, the output will cycle through the possible Bkgd sources, and the Quad Split
		# Quad - Black	The specified quadrant displays black when the GPI is triggered
		# Quad - Bkgd #	The specified quadrant displays the selected Bkgd source when the GPI is triggered
		# Quad - Cycle	The specified quadrant output cycles through the available input sources and black when the GPI is triggered
		Bkgd # - Tally 1	Select this option to have the GPI control the first on-screen tally associated with the specified input on the QSP-8229A
		Bkgd # - Tally 2	Select this option to have the GPI control the second on-screen tally associated with the specified input on the QSP-8229A
	Trigger	Edge*	Performs the function when a transition edge is detected on the GPI input. The Low-to-High or High-to-Low active edge is set by the Polarity control.
		Level	Performs the function when a voltage level is driven on the GPI input. The voltage level High or Low is set by the Polarity control.
	Polarity	High/Rising	Sets the polarity of the edge or level trigger. In the case of edge trigger, a Low-to-High transition starts the function. In the case of level trigger, a high level starts the function.
		Low/Falling*	Sets the polarity of the edge or level trigger. In the case of the edge trigger, a High-to-Low transition starts the function. In the case of a level trigger, a low level starts the function.

Remote Control Configuration

Table 5.6 outlines the options in the **Remote Control** tab for the QSP-8229A. This tab provides options for configuring communications between the QSP-8229A and tally device.

Table 5.6 Remote Control Tab Items

Menu	Item	Parameter	Description
Serial Port	Port Enabled	Selected	Enables the Serial COM port on the rear module to communicate with a serial device
		Cleared*	Disables the Serial COM port
	Protocol	TSL UMD v3.1	Selects the serial communication protocol for the external device connected to the Serial COM port on the rear module
	Port Type	#	Selects the electrical standard for the Serial COM port on the rear module. The default is RS 232.
	Bit Rate	#	Selects the bit rate for the external device connected to the Serial COM port. The default is 38400.
	Data Bits	#	Selects the number of data bits transmission (character length). The default is 8.
	Parity		Sets the Parity type. The default is None.
	Stop Bits	#	Sets the number of stop bits transmission. The default is 1.
Ethernet Port	TSL UMD v3.1 - Enabled	Selected	Enables ethernet communication from the Ethernet 10/100 port on the QSP-8229A rear module to a device using the Tally Systems Ltd. (TSL) UMD protocol v3.1
		Cleared*	Disables the Ethernet 10/100 port for tallies
	Role	Server*	The QSP-8229A functions as a host, or socket listener, on the network
		Client	The QSP-8229A functions as a service requester that initiates communications with a server
	Protocol	TCP*	Select this option if your device uses the Transmission Control Protocol (TCP) for ethernet communications
		UDP	Select this option if your device uses the User Data Protocol (UDP) for ethernet communications
	Local Port	#	Specifies the port number for the tally device. The default is 9000.
	Remote IP Address ^a	#	Specifies the IP Address for the server the QSP-8229A sends requests to. The default is 0.0.0.0.
	Remote Port ^a	#	Specifies the port number for the server the QSP-8229A sends requests to. The default is 0.

a. This menu item is only applicable when Role is set to Client.

Ethernet Configuration

Table 5.7 outlines the options in the **Ethernet** tab for the QSP-8229A. This tab provides options for configuring the ethernet communication for the QSP-8229A.

Table 5.7 Ethernet Tab Items

Menu	Item	Parameter	Description	
Ethernet	Method	Static	User manually supplies the Ethernet Setup settings	
		DHCP*	Automates the assignment of the Ethernet settings	
	IP Address	##.##.###	The IP Address for the card	
	Subnet Mask	###.##.#	The subnet mask for the card	
	Default Gateway	##.##.#	The gateway for communication outside of the local area network (LAN)	
	Apply Changes		Applies and saves any changes made to the Ethernet Settings	
	Cancel		Cancels any setting changes and resets the Ethernet Settings to the previous values	
	Ethernet Status	OK		Ethernet communications for the card are valid
		Link Down		Ethernet communications for the card are invalid. The ethernet cable may be disconnected from the rear module or the network may be down.
		No IP Address		The following conditions are occurring: <ul style="list-style-type: none"> • The Method is set to DHCP. • The ethernet cable connected to card rear module is securely connected. • A valid IP Address is no longer available. The DHCP server may be down or is still powering up after a loss of power.
	MAC Address (read-only)	###:###:###:###:###:###	The MAC Address for the card	

Personality Configuration

Table 5.8 outlines the options in the **Personality** tab for the QSP-8229A.

Table 5.8 Personality Tab Items

Menu	Item	Parameter	Description
Timing Display	Timing Display	Relative to Reference*	The BKGD A, B, C, D Timing fields in the Signal tab display the timing values relative to the selected analog reference
		Input to Output	The BKGD A, B, C, D Timing fields in the Signal tab display the timing values relative to the SDI output of the card
Card Lock	Edit Permission	Unlocked*	All menu items are unlocked and can be edited
		Locked	All menu items, except this one, are locked and read-only. The card can still be controlled by GPI if this features was enabled prior to locking.
Enable Fan Alarm^a	Stalled Fan	Selected*	The FPGA Fan field in the Signal tab reports when the fan on the card surface is not operating correctly
		Cleared	Disables this reporting feature

a. This field is only displayed for when using Board Rev 3 or higher.

Load/Save

The menu items available in the **Load/Save** tab enable you to reset menu parameters for the card to the factory default values.

Table 5.9 Load/Save Tab Items

Menu	Item	Parameter	Description
Global Settings	Load Factory Defaults		Resets all DashBoard parameters and values (excluding ethernet, reference, and output format settings) to the factory default values

Proc Amps Tab

The following table summarizes the **Proc Amps** tab options available in DashBoard.

Table 5.10 Proc Amps Tab Items

Menu	Item	Parameters	Description
Out #	Enable	Selected*	Enables the adjustment of Proc Amp settings for the selected output
		Cleared	The Proc Amp settings for the selected output are inactive
	Video Gain (%)	0 to 200 ^a	Adjusts the Chroma and Luma Gain values simultaneously
	Chroma Gain (%)	0 to 200 ^b	Adjusts the Cr and Cb values of the output video signals: <ul style="list-style-type: none"> Increasing the gain increases the saturation of colors Decreasing the gain de-saturates the colors until the signal is black and white
	CB Gain (%)	0 to 200 ^c	Adjusts the Cb component of the chrominance video signal: <ul style="list-style-type: none"> Increasing the value causes the video signal colors to become increasingly saturated with blue Decreasing the value de-saturates blue from the video signal
	Black Offset (IRE)	-8 to 100 ^d	Selects how much of the input video signal values are mapped to black in the output signal: <ul style="list-style-type: none"> Increasing the value increases the black level and lightens the image Decreasing the value darkens the image
	Procamp	Reset	Resets the Proc Amp menu settings for the selected output to the default values

- a. The default value is 100.
- b. The default value is 100.
- c. The default value is 100.
- d. The default value is 0.

Quad Split Tabs

The following tables summarize the **Quad Split** tab options available in DashBoard.

Video/Label Tab

Table 5.11 summarizes the options available in the **Video/Label** tab for the Quad Split.

Table 5.11 Video/Label Tab Items

Menu	Item	Parameters	Description
Quadrant Selection	Upper Left	Black	The upper left quadrant displays black
		Bkgd A*	The upper left quadrant displays the Bkgd A source
		Bkgd B	The upper left quadrant displays the Bkgd B source
		Bkgd C	The upper left quadrant displays the Bkgd C source
		Bkgd D	The upper left quadrant displays the Bkgd D source
	Upper Right	Same parameters as above. The default setting is Bkgd B.	
	Lower Left	Same parameters as above. The default setting is Bkgd C.	
	Lower Right	Same parameters as above. The default setting is Bkgd D.	
Source Label	Bkgd A	Bkgd A*	Enter text in this field to configure the label for the specified source. Note that a blank field hides the text overlay in the display quadrant. This label is applied to the Tally/Border tab items, the Bkgd # tab items, and the Config tab items.
	Bkgd B	Bkgd B*	
	Bkgd C	Bkgd C*	
	Bkgd D	Bkgd D*	

Tally/Border Tab

Table 5.12 summarizes the options available in the **Tally/Border** tab for the Quad Split.

Table 5.12 Tally/Border Tab Items

Menu	Item	Parameters	Description
Tally Control	Tally Position	No tallies shown*	
		Tally 1 on left, Tally 2 on right	Assigns Tally 1 to the left, and Tally 2 to the right
		Tally 2 on left, Tally 1 on right	Assigns Tally 1 to the right, and Tally 2 to the left
		Tallies displayed in border	
	Tally Color	Tally 1 is red, Tally 2 is green*	
		Tally 2 is red, Tally 1 is green	

Table 5.12 Tally/Border Tab Items

Menu	Item	Parameters	Description
Border Control	Border Color	Color*	Sets the border around a quadrant to the default color for the source ^a
		Black	Sets the border around the quadrants to black
		White	Sets the border around the quadrants to white
		Transparent	The border around the quadrants is fully transparent
	Border Size	0-50 ^b	Adjusts the width, in pixel units, of the border around the specified source. Note that a value of 0 removes the border.

- a. The default colors for the sources are as follows: Bkgd A is set to tan, Bkgd B is set to purple, Bkgd C is set to cyan, and Bkgd D is set to gray.
- b. The default value is 4.

Bkgd A, B, C, D Tabs

Table 5.13 summarizes the menu options in the **Bkgd A, B, C, D** sub-tabs located at the bottom of the **Quad Split** tab. Note that the options described below are available for each background source.

Table 5.13 Bkgd # Tab Items

Menu	Item	Parameters	Description
Bkgd # - Label	Bkgd #	#	Enter text to assign a new QSP-8229A static label to the source
	TSL UMD	Ignore	The dynamic label information for this input is ignored; the QSP-8229A static label is displayed instead
		Append*	The dynamic label information is displayed after the QSP-8229A static label
		Prepend	The dynamic label information is displayed before the QSP-8229A static label
		Replace	The dynamic label information for this input is displayed; the QSP-8229A static label is ignored
	TSL Address	0-126 ^a	Assigns a Display Address for the specified input
Bkgd # - Color	Red	0-255	Sets the background color of the source label to red
	Green	0-255	Sets the background color of the source label to green
	Blue	0-255	Sets the background color of the source label to blue
	Transparency	0-100	Sets the background of the source label to 0 (opaque), transparent, to 100 (fully transparent). The default value is 50.

- a. The default value for Bkgd A is 0, Bkgd B is 1, Bkgd C is 2, and Bkgd D is 3.

Appendix B. Specifications

In This Appendix

This appendix provides information on the specifications for your QSP-8229A. Note that specifications are subject to change without notice.

The following topics are discussed:

- 8310AR-033 and 8320AR-033 Specifications
- 8320AR-049 Specifications

8310AR-033 and 8320AR-033 Specifications

Table 6.1 provides technical specifications when using the 8310AR-033 or 8320AR-033 Rear Modules.

Table 6.1 QSP-8229A Technical Specifications - 8310AR-033 and 8320AR-033

Category	Parameter	Specification
Serial Digital Video Inputs	Number of Inputs	4
	SDI Data Rates and SMPTE Standards Accommodated	SMPTE 259M (270 Mbps) SMPTE 292M (1.485 Gbps)
	Impedance	75 Ohms
	Return Loss	< -15dB, 0 to 1.5GHz
	Equalization	80m
Serial Digital Video Outputs	Number of Outputs	4
	Impedance	75 Ohms
	Return Loss	OUT 1: -15dB, 0 to 1.5GHz OUT 2-4: <-15dB, 0 to 1.5GHz
	Signal Level	800mV +/-10%
	DC Offset	0+/-50mV
	Rise and Fall Time	SD: 900ps typical HD: 150ps typical
	Overshoot	<10% typical
Power	Power Consumption	22W

8320AR-049 Specifications

Table 6.2 provides technical specifications when using the 8320AR-049 Rear Module.

Table 6.2 QSP-8229A Technical Specifications - 8320AR-049

Category	Parameter	Specification
Serial Digital Video Inputs	Number of Looping Inputs	4
	SDI Data Rates and SMPTE Standards Accommodated	SMPTE 259M (270 Mbps) SMPTE 292M (1.485 Gbps)
	Impedance	75 Ohms
	Return Loss	Not applicable for looping input
	Equalization	50 m
Serial Digital Video Outputs	Number of Outputs	4
	Number of Looping Outputs	4 (<i>8320AR-049 Rear Module only</i>)
	Impedance	75 Ohms
	Return Loss	OUT 1-4: <15dB, 0 to 1.5GHz
	Signal Level	800mV +/-10%
	DC Offset	0+/-50mV
	Rise and Fall Time	SD: 900ps typical HD: 150ps typical
	Overshoot	<10% typical
Power	Power Consumption	22W

Appendix C. Service Information

In This Chapter

This chapter contains the following sections:

- Troubleshooting Checklist
- Warranty and Repair Policy

Troubleshooting Checklist

Routine maintenance to this openGear product is not required. In the event of problems with your QSP-8229A, the following basic troubleshooting checklist may help identify the source of the problem. If the card or frame still does not appear to be working properly after checking all possible causes, please contact your openGear products distributor, or the Technical Support department at the numbers listed under the “**Contact Us**” section.

1. **Visual Review** — Performing a quick visual check may reveal many problems, such as connectors not properly seated or loose cables. Check the card, the frame, and any associated peripheral equipment for signs of trouble.
2. **Power Check** — Check the power indicator LED on the distribution frame front panel for the presence of power. If the power LED is not illuminated, verify that the power cable is connected to a power source and that power is available at the power main. Confirm that the power supplies are fully seated in their slots. If the power LED is still not illuminated, replace the power supply with one that is verified to work.
3. **Reference Signal Status** — Verify that the analog reference (blackburst or tri-level) is supplied on one of the three reference inputs. Check the Reference Input and the Output Format settings. Also check the status of the reference by navigating to the Reference Status field located on the Signal tab in DashBoard.
4. **Input Signal Status** — Verify that source equipment is operating correctly and that a valid signal is being supplied.
5. **Output Signal Path** — Verify that destination equipment is operating correctly and receiving a valid signal.
6. **Unit Exchange** — Exchanging a suspect unit with a unit that is known to be working correctly is an efficient method for localizing problems to individual units.
7. **Re-load the Factory Defaults** — If the card appears to be working and reports no errors, but is not generating an active picture or outputs black, restoring the default factory configuration may fix the problem.

Warranty and Repair Policy

The QSP-8229A is warranted to be free of any defect with respect to performance, quality, reliability, and workmanship for a period of FIVE (5) years from the date of shipment from our factory. In the event that your QSP-8229A proves to be defective in any way during this warranty period, Ross Video Limited reserves the right to repair or replace this piece of equipment with a unit of equal or superior performance characteristics.

Should you find that this QSP-8229A has failed after your warranty period has expired, we will repair your defective product should suitable replacement components be available. You, the owner, will bear any labor and/or part costs incurred in the repair or refurbishment of said equipment beyond the FIVE (5) year warranty period.

In no event shall Ross Video Limited be liable for direct, indirect, special, incidental, or consequential damages (including loss of profits) incurred by the use of this product. Implied warranties are expressly limited to the duration of this warranty.

This QSP-8229A User Manual provides all pertinent information for the safe installation and operation of your openGear Product. Ross Video policy dictates that all repairs to the QSP-8229A are to be conducted only by an authorized Ross Video Limited factory representative. Therefore, any unauthorized attempt to repair this product, by anyone other than an authorized Ross Video Limited factory representative, will automatically void the warranty. Please contact Ross Video Technical Support for more information.

In Case of Problems

Should any problem arise with your QSP-8229A, please contact the Ross Video Technical Support Department. (Contact information is supplied at the end of this publication.)

A Return Material Authorization number (RMA) will be issued to you, as well as specific shipping instructions, should you wish our factory to repair your QSP-8229A. If required, a temporary replacement frame will be made available at a nominal charge. Any shipping costs incurred will be the responsibility of you, the customer. All products shipped to you from Ross Video Limited will be shipped collect.

The Ross Video Technical Support Department will continue to provide advice on any product manufactured by Ross Video Limited, beyond the warranty period without charge, for the life of the equipment.

Notes:

Notes:

Contact Us

Contact our friendly and professional support representatives for the following:

- Name and address of your local dealer
- Product information and pricing
- Technical support
- Upcoming trade show information

Technical Support

Telephone: +1 613 • 652 • 4886
After Hours Emergency: +1 613 • 349 • 0006
Email: techsupport@rossvideo.com

General Information

Telephone: +1 613 • 652 • 4886
Fax: +1 613 • 652 • 4425
Email: solutions@rossvideo.com
Website: <http://www.rossvideo.com>

Visit Us

Visit our website for:

- Company information and news
- Related products and full product lines
- Online catalog
- Testimonials