

# GPI-100

## VANC to GPIO Trigger Inserter/Decoder User Manual

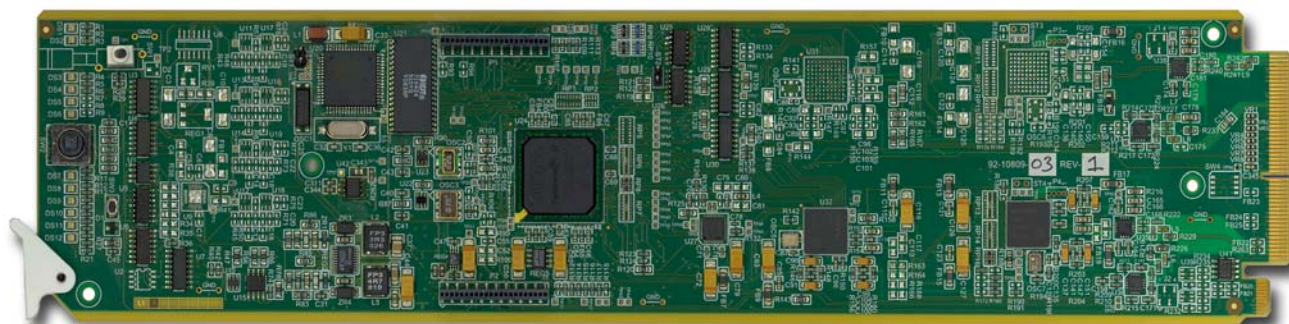

---

# GPI-100 User Manual

- Ross Part Number: GPI100DR-004-03
- Release Date: May 10, 2012.

The information in this manual is subject to change without notice or obligation.

---

## Copyright

© 2012 Ross Video Limited. All rights reserved.

Contents of this publication may not be reproduced in any form without the written permission of Ross Video Limited. Reproduction or reverse engineering of copyrighted software is prohibited.

---

## Patents

This product is protected by the following US Patents: 4,205,346; 5,115,314; 5,280,346; 5,561,404; 7,304,886; 7,508,455; 7,602,446; 7,834,886; 7,914,332. This product is protected by the following Canadian Patents: 2039277; 1237518; 1127289. Other patents pending.

---

## Notice

The material in this manual is furnished for informational use only. It is subject to change without notice and should not be construed as commitment by Ross Video Limited. Ross Video Limited assumes no responsibility or liability for errors or inaccuracies that may appear in this manual.

---

## Trademarks

-  is a registered trademark of Ross Video Limited.
- Ross, ROSS, ROSS®, and MLE are registered trademarks of Ross Video Limited.
- openGear® is a registered trademark of Ross Video Limited.
- DashBoard Control System™ is a trademark of Ross Video Limited.
- All other product names and any registered and unregistered trademarks mentioned in this manual are used for identification purposes only and remain the exclusive property of their respective owners.

---

# Important Regulatory and Safety Notices to Service Personnel

Before using this product and any associated equipment, refer to the “**Important Safety Instructions**” listed below to avoid personnel injury and to prevent product damage.

Product may require specific equipment, and/or installation procedures to be carried out to satisfy certain regulatory compliance requirements. Notices have been included in this publication to call attention to these specific requirements.

## Symbol Meanings



---

*This symbol on the equipment refers you to important operating and maintenance (servicing) instructions within the Product Manual Documentation. Failure to heed this information may present a major risk of damage to persons or equipment.*

---



---

**Warning** — The symbol with the word “**Warning**” within the equipment manual indicates a potentially hazardous situation, which, if not avoided, could result in death or serious injury.

---



---

**Caution** — The symbol with the word “**Caution**” within the equipment manual indicates a potentially hazardous situation, which, if not avoided, may result in minor or moderate injury. It may also be used to alert against unsafe practices.

---



---

**Notice** — The symbol with the word “**Notice**” within the equipment manual indicates a potentially hazardous situation, which, if not avoided, may result in major or minor equipment damage or a situation which could place the equipment in a non-compliant operating state.

---



---

**ESD Susceptibility** — This symbol is used to alert the user that an electrical or electronic device or assembly is susceptible to damage from an ESD event.

---

## Important Safety Instructions



---

**Caution** — This product is intended to be a component product of the DFR-8300 series frame. Refer to the DFR-8300 Series Frame User Manual for important safety instructions regarding the proper installation and safe operation of the frame as well as its component products.

---



---

**Warning** — Certain parts of this equipment namely the power supply area still present a safety hazard, with the power switch in the OFF position. To avoid electrical shock, disconnect all A/C power cords from the chassis’ rear appliance connectors before servicing this area.

---



---

**Warning** — Service barriers within this product are intended to protect the operator and service personnel from hazardous voltages. For continued safety, replace all barriers after any servicing.

*This product contains safety critical parts, which if incorrectly replaced may present a risk of fire or electrical shock. Components contained with the product’s power supplies and power supply area, are not intended to be customer serviced and should be returned to the factory for repair. To reduce the risk of fire, replacement fuses must be the same time and rating. Only use attachments/accessories specified by the manufacturer.*

---

## EMC Notices

### United States of America FCC Part 15

This equipment has been tested and found to comply with the limits for a class A Digital device, pursuant to part 15 of the FCC Rules. These limits are designed to provide reasonable protection against harmful interference when the equipment is operated in a commercial environment. This equipment generates, uses, and can radiate radio frequency energy and, if not installed and used in accordance with the instruction manual, may cause harmful interference to radio communications. Operation of this equipment in a residential area is likely to cause harmful interference in which case the user will be required to correct the interference at their own expense.



**Notice** — *Changes or modifications to this equipment not expressly approved by Ross Video Limited could void the user's authority to operate this equipment.*

---

### CANADA

This Class "A" digital apparatus complies with Canadian ICES-003.

Cet appareil numérique de la classe "A" est conforme à la norme NMB-003 du Canada.

### EUROPE

This equipment is in compliance with the essential requirements and other relevant provisions of CE Directive 93/68/EEC.

### INTERNATIONAL

This equipment has been tested to **CISPR 22:1997** along with amendments **A1:2000** and **A2:2002**, and found to comply with the limits for a Class A Digital device.



**Notice** — *This is a Class A product. In domestic environments, this product may cause radio interference, in which case the user may have to take adequate measures.*

---

## Maintenance/User Serviceable Parts

Routine maintenance to this openGear product is not required. This product contains no user serviceable parts. If the module does not appear to be working properly, please contact Technical Support using the numbers listed under the "Contact Us" section on the last page of this manual. All openGear products are covered by a generous 5-year warranty and will be repaired without charge for materials or labor within this period. See the "Warranty and Repair Policy" section in this manual for details.

## Environmental Information

**The equipment that you purchased required the extraction and use of natural resources for its production. It may contain hazardous substances that could impact health and the environment.**

To avoid the potential release of those substances into the environment and to diminish the need for the extraction of natural resources, Ross Video encourages you to use the appropriate take-back systems. These systems will reuse or recycle most of the materials from your end-of-life equipment in an environmentally friendly and health conscious manner.

The crossed out wheelie bin symbol invites you to use these systems.



If you need more information on the collection, re-use, and recycling systems, please contact your local or regional waste administration.

You can also contact Ross Video for more information on the environmental performance of our products.

---

## Company Address



### **Ross Video Limited**

8 John Street  
Iroquois, Ontario, K0E 1K0  
Canada

### **Ross Video Incorporated**

P.O. Box 880  
Ogdensburg, New York  
USA 13669-0880

General Business Office: (+1) 613 • 652 • 4886

Fax: (+1) 613 • 652 • 4425

Technical Support: (+1) 613 • 652 • 4886

After Hours Emergency: (+1) 613 • 349 • 0006

E-mail (Technical Support): [techsupport@rossvideo.com](mailto:techsupport@rossvideo.com)

E-mail (General Information): [solutions@rossvideo.com](mailto:solutions@rossvideo.com)

Website: <http://www.rossvideo.com>

# Contents

- Introduction 1**
  - Overview..... 1-2
    - Features..... 1-2
  - Functional Block Diagram..... 1-3
  - User Interfaces ..... 1-4
    - DashBoard Control System™ ..... 1-4
    - On-screen Menu System..... 1-4
  - Documentation Terms and Conventions..... 1-5
  
- Installation 2**
  - Before You Begin ..... 2-2
    - Static Discharge..... 2-2
    - Unpacking..... 2-2
  - Quick Start ..... 2-3
  - Installing the GPI-100..... 2-5
    - Rear Modules..... 2-5
    - Installing a Rear Module ..... 2-5
    - Installing the GPI-100 ..... 2-6
  - Cabling for the GPI-100 ..... 2-7
    - Rear Module Cabling ..... 2-7
    - Connections Overview ..... 2-7
  - Software Upgrades..... 2-9
  
- User Controls 3**
  - Card Overview ..... 3-2
  - Control and Monitoring Features..... 3-3
    - Status and Selection LEDs on the GPI-100..... 3-3
  
- Configuration 4**
  - General Settings ..... 4-2
  - Configuring GPIOs ..... 4-3
  - Setting the Logging Timestamp..... 4-4
  - Downloading Log Files ..... 4-5
  - Monitoring ..... 4-6
  
- Using the On-Screen Menus 5**
  - On-screen Display Overview ..... 5-2
    - OSD Switch Overview ..... 5-2
  - OSD Layout and Navigation..... 5-3
  - Using the Menus ..... 5-4
  
- Specifications 6**
  - Technical Specifications ..... 6-2

<b>Service Information</b>	<b>7</b>
Troubleshooting Checklist .....	7-2
Reset Button.....	7-2
Warranty and Repair Policy .....	7-3

# Introduction

---

## In This Chapter

This chapter contains the following sections:

- Overview
- Functional Block Diagram
- User Interfaces
- Documentation Terms and Conventions

## A Word of Thanks

Congratulations on choosing an openGear GPI-100 VANC to GPIO Trigger Inserter/Decoder. Your GPI-100 is part of a full line of Digital Products within the openGear Terminal Equipment family of products, backed by Ross Video's experience in engineering and design expertise since 1974.

You will be pleased at how easily your new GPI-100 fits into your overall working environment. Equally pleasing is the product quality, reliability and functionality. Thank you for joining the group of worldwide satisfied Ross Video customers!

Should you have a question pertaining to the installation or operation of your GPI-100, please contact us at the numbers listed on the back cover of this manual. Our technical support staff is always available for consultation, training, or service.

---

## Overview

The GPI-100 enables GPIO triggers to be carried in the Vertical Ancillary (VANC) data area of an SDI (SMPTE 259) or HD-SDI (SMPTE 292) video signal, in accordance with SMPTE 291 and other related standards. The GPI-100, as an encoder, reads GPIO inputs and inserts them into the VANC. As a decoder, it reads the VANC and applies the data to GPIO outputs. This allows GPIO enabled equipment to be triggered remotely through the video path.

The GPI-100 provides a simple interface allowing the carriage of GPIO triggers as part of the video signal. For example:

- The card is set to act as an encoder or a decoder. This determines if the card will read and place the GPIOs into the VANC (encode) or read the VANC and assert the GPIOs (decode).
- GPIO triggers are logged both to the screen and to a log file. The log file can be transferred from the card to a PC through a network connection.
- Entries in the log file are time stamped. The GPI-100 can be set to use an NTP time server, time code or its own internal clock as its time reference.
- One GPI-100 can insert trigger for many GPI-100s acting as receivers. There are eight GPIOs available and a receiver can act on all or some of them.
- Card configuration can be uploaded to a PC. This configuration can be used to reconfigure a card back to a known state or to quickly clone the card setup into other cards.

## Features

The following features make the GPI-100 the best solution for carrying GPIO triggers with the video:

- Operates automatically with popular SD and HD video formats
- Each card can be set up to either encode or decode
- Frame-accurate triggering: each trigger is delivered within one video frame time
- All triggers are logged as proof of delivery
- Allows you to select a unique Originator ID so another operator's triggers will not affect your GPIO outputs
- Video bypass capability
- Reports status and can be configured remotely via the DashBoard Control System™
- Fits openGear DFR-8300 series frames
- 5-year transferable warranty

# Functional Block Diagram

This section provides the functional block diagram that outlines the workflow of the GPI-100.

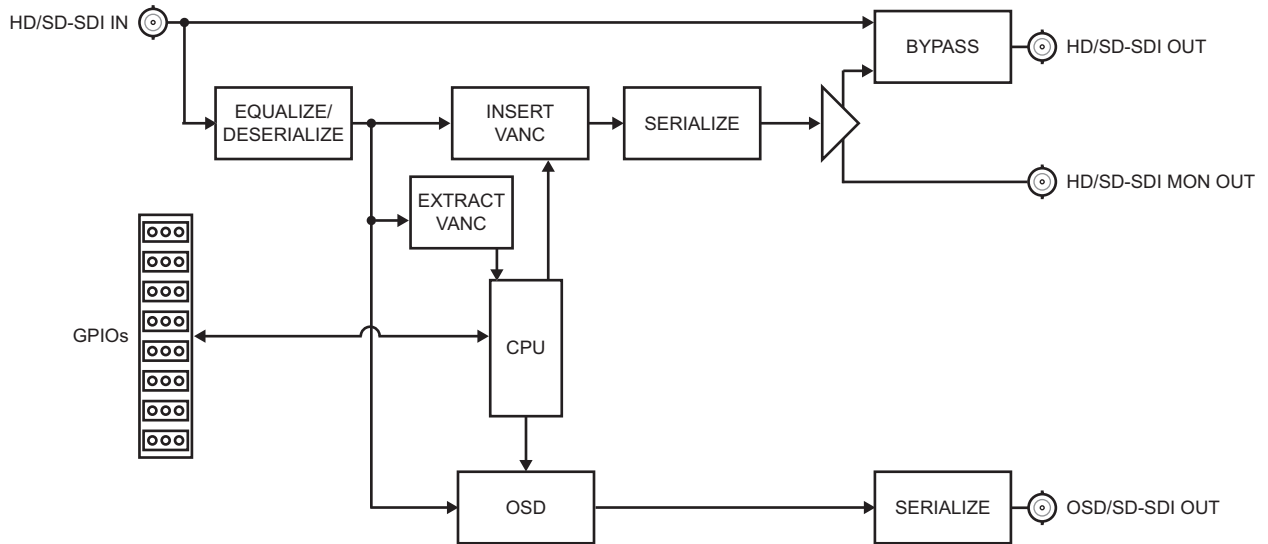

**Figure 1.1** Simplified Block Diagram

---

# User Interfaces

The GPI-100 includes two user interfaces.

## DashBoard Control System™

The DashBoard Control System™ enables you to monitor and control openGear frames and cards from a computer. DashBoard communicates with other cards in the DFR-8300 series frame through the Network Controller Card. The DashBoard Control System software and manual are available for download from our website.

### *For More Information...*

- on the GPI-100 menus in DashBoard, refer to the chapter “**Configuration**” on page 4-1.
- on using DashBoard, refer to the *DashBoard User Manual* available from our website.

## On-screen Menu System

For maximum flexibility of configuration, the GPI-100 also provides a Heads-Up Display on an SDI video output. When activated, card status and parameters can be viewed and adjusted using the card-mounted finger joystick and an easy to use menu system.

### *For More Information...*

- on the card-edge controls, refer to the section “**Card Overview**” on page 3-2.
- on the on-screen menu system, refer to the chapter “**Using the On-Screen Menus**” on page 5-1.

---

# Documentation Terms and Conventions

The following terms and conventions are used throughout this manual:

- **“Board”** and **“Card”** refer to the GPI-100 card itself, including all components and switches.
- **“DashBoard”** refers to the DashBoard Control System™.
- **“Frame”** refers to the DFR-8300 series frame that houses the GPI-100 card.
- **“GPIO”** means General Purpose Input-Output. This term is commonly used in the broadcast industry to refer to DC signals used by one device to control another.
- **“Operator”** and **“User”** refer to the person who uses the GPI-100.
- **“Rear Module”** refers to the connector module at the rear of the frame, into which the GPI-100 is inserted.
- **“System”** and **“Video system”** refer to the mix of interconnected production and terminal equipment in which the GPI-100 operates.
- **“VANC”** is the Vertical Ancillary data space of a serial digital video signal, and is defined by SMPTE standard 291M.



# Installation

---

## In This Chapter

This chapter provides instructions for installing the GPI-100, installing the card into the frame, cabling details, and updating the card software.

The following topics are discussed:

- Before You Begin
- Quick Start
- Installing the GPI-100
- Cabling for the GPI-100
- Software Upgrades

---

## Before You Begin

Before proceeding with the instructions in this chapter, ensure that your DFR-8300 series frame is properly installed according to the instructions in the *DFR-8300 Series User Manual*.

### Static Discharge

Throughout this chapter, please heed the following cautionary note:



---

**ESD Susceptibility** — *Static discharge can cause serious damage to sensitive semiconductor devices. Avoid handling circuit boards in high static environments such as carpeted areas and when synthetic fiber clothing is worn. Always exercise proper grounding precautions when working on circuit boards and related equipment.*

---

### Unpacking

Unpack each GPI-100 you received from the shipping container and ensure that all items are included. If any items are missing or damaged, contact your sales representative or Ross Video directly.

---

## Quick Start

Assuming you have a DFR-8300 series frame, two GPI-100 cards and two Rear Modules, the following steps will get you started with VANC metadata insertion:

1. Connect the DFR-8300 series frame to your LAN. Refer to the *DFR-8300 Series User Manual* and *MFC-8300 Series User Manual* for details.
2. Install DashBoard on a computer connected to the LAN. The DashBoard Control System™ software and user manual are available from the Ross Video website.
3. Install each rear module in the frame, as described in the section “**Installing a Rear Module**” on page 2-5.
4. Install each GPI-100 card into a rear module as described in the section “**Installing the GPI-100**” on page 2-6. One card will be used to insert the GPIO triggers into the VANC and the second card will be used to read the GPIOs from the VANC.
5. Connect a 292 or 259 signal to the **SDI IN** BNC on the rear module of the encode card. Refer to the section “**Cabling for the GPI-100**” on page 2-7 for details.
6. Connect the **SDI OUT** BNC of the encode card to the **SDI IN** BNC of the decode card.
7. Launch DashBoard on your computer. It should automatically find your frame within a minute or two.

### Configure a GPI-100 as an Encoder

1. Click the “+” next to the frame name to show the cards in the frame, then double-click the GPI-100 to be used as the encoder.
2. Select the **Settings** tab and set the **Card Function** to **Encode**. It is also a good idea to give the card a meaningful name. This makes it easier to identify it in a frame which contains many cards. Click **Accept** to apply these changes.
3. Select the **GPIO Mask** tab and select the boxes for all eight GPIOs. It will not matter if you do not connect a GPIO to every connection because the connection will be open by default. Click **Save** to apply this change.
4. Connect a GPIO source (for example, a switch) to one or more of the GPIO inputs of the card as described in the section “**Cabling for the GPI-100**” on page 2-7.

### Configure a GPI-100 as a Decoder

1. Click the “+” next to the frame name to show the cards in the frame, then double-click the GPI-100 to be used as the decoder.
2. Select the **Settings** tab and set the **Card Function** to **Decode**. Give the card a name. Click **Accept** to apply these changes.
3. Select the **GPIO Mask** tab and select the boxes for all eight GPIOs. Click **Save** to apply this change.
4. Connect one or more of the GPIO outputs of the card to a GPIO controlled device. Your GPIO source is now driving your GPIO controlled device through the VANC.
5. You must set the time for the log’s time stamp to be accurate:
  - Select the **Time** tab and set the time according to the instructions in the section “**Setting the Logging Timestamp**” on page 4-4.
  - Select a **Time Source** (Timecode is recommended if it is available in the VANC).
  - Set the other parameters if required for the Time Source.

- Click **Accept** to apply your changes.
6. Select the **Log** tab of the decode card. Each time your GPIO source sends a trigger it appears in the log. This tab shows the last 20 entries of the log file maintained on the GPI-100. The complete log can be downloaded to the PC by clicking the **Download Logfile Save** button.

---

# Installing the GPI-100

This section outlines how to install a rear module and card in a DFR-8300 series frame. Refer to the section “**Cabling for the GPI-100**” on page 2-7 for cabling details.

## Rear Modules

When installing the GPI-100:

- **DFR-8310 series frames** — The **MDL-R10** Full Rear Module is required. The GPI-100 is not compatible with the DFR-8310-BNC frame.
- **DFR-8321 series frames** — The **MDL-R20** Full Rear Module is required.

## Installing a Rear Module

If the Rear Module is installed, proceed to the section “**Installing the GPI-100**” on page 2-6.

Use the following procedure to install a Rear Module in your DFR-8300 series frame:

1. Locate the card frame slots on the rear of the frame.
2. Remove the Blank Plate from the slot you have chosen for the GPI-100 installation.
3. Install the bottom of the Rear Module in the **Module Seating Slot** at the base of the frame’s back plane. (**Figure 2.1**)

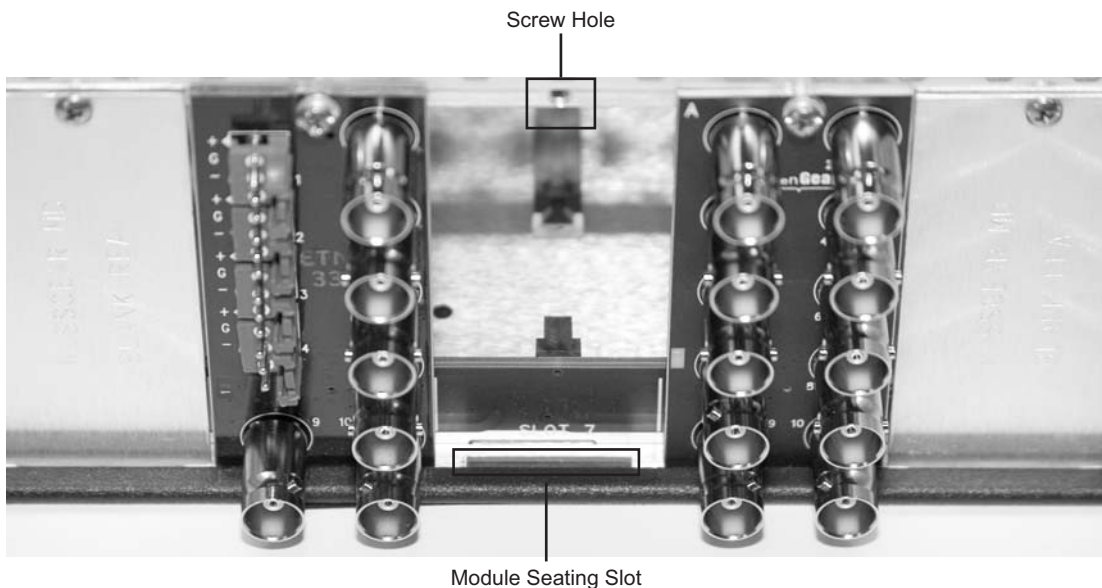

**Figure 2.1** Rear Module Installation in a DFR-8300 Series Frame (GPI-100 not shown)

4. Align the top hole of the Rear Module with the screw on the top-edge of the frame back plane.
5. Using a Phillips screwdriver and the supplied screw, fasten the Rear Module to the back plane of the frame. Do not over tighten.
6. Ensure proper frame cooling and ventilation by having all rear frame slots covered with Rear Modules or Blank Plates.

This completes the procedure for installing a Rear Module in your DFR-8300 series frame.

## Installing the GPI-100

Use the following procedure to install the GPI-100 in a DFR-8300 series frame:

1. Locate the Rear Module you installed in the procedure “**Installing a Rear Module**” on page 2-5.



---

**Notice** — *Heat and power distribution requirements within a frame may dictate specific slot placements of cards. Cards with many heat-producing components should be arranged to avoid areas of excess heat build-up, particularly in frames using convectional cooling.*

---

2. Hold the GPI-100 by the edges and carefully align the card-edges with the slots in the frame.
3. Fully insert the card into the frame until the rear connection plus is properly seated in the Rear Module.
4. Verify whether your rear module label is self-adhesive by checking the back of the label for a thin wax sheet. You must remove this wax sheet before affixing the label.
5. Affix the supplied rear module label to the BNC area of the Rear Module.

This completes the procedure for installing the GPI-100 in a DFR-8300 series frame.

# Cabling for the GPI-100

This section provides information for connecting cables to the installed Rear Modules on the DFR-8300 series frames. Connect the input and output cables according to the following sections.

## Rear Module Cabling

This section provides cabling diagrams for the rear modules. The type of rear module depends on the frame the card is installed in.

### DFR-8310 Series Frames

Each **MDL-R10** occupies one slot and accommodates one card. The **MDL-R10** provides one SDI input, a bypass relay from **BNC 1** to **BNC 3**, bi-directional Logic-level GPIOs, and a monitoring video output. (Figure 2.2)

### DFR-8321 Series Frames

Each **MDL-R20** occupies two slots and accommodates one card. The **MDL-R20** provides one SDI input, a bypass relay from **BNC 1** to **BNC 3**, bi-directional Logic-level GPIOs, and a monitoring video output. (Figure 2.3)

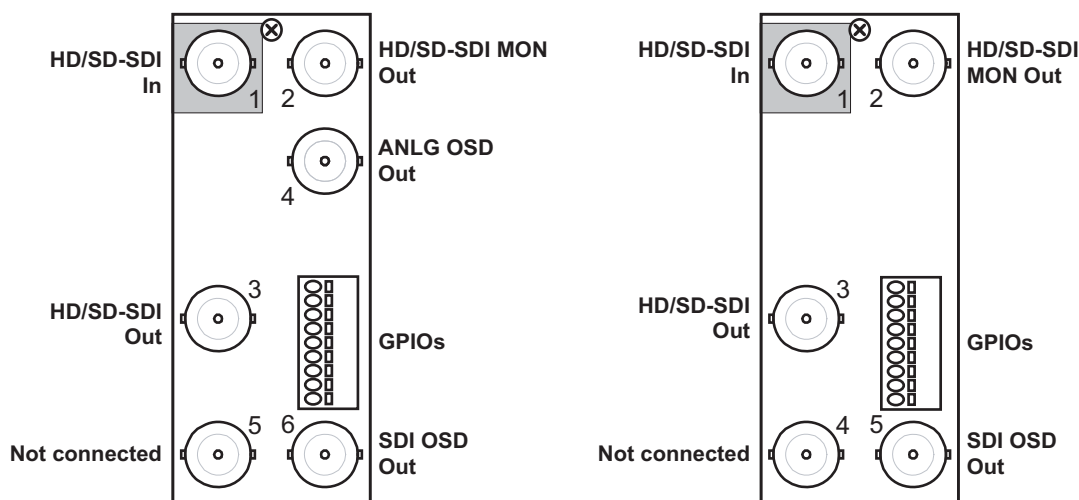

Figure 2.2 Cabling for the MDL-R10 Rear Module Figure 2.3 Cabling for the MDL-R20 Rear Module

## Connections Overview

This section briefly outlines the types of connections available on the rear modules.

### SDI In — BNC 1

**BNC 1** accepts an SDI (SMPTE 259) or HD-SDI (SMPTE 292) video signal. The GPI-100 requires this input in all cases. It inserts or extracts VANC packets in this signal and routes the resulting output to **BNC 3**. The input signal is internally terminated in 75ohms when the GPI-100 is active; when the GPI-100 is in bypass, the termination is provided by the downstream equipment connected to **BNC 3**.

## SDI Out — BNC 3

**BNC 3** carries the main program output from the GPI-100, consisting of the signal applied to **BNC 1**, with VANC data packets inserted. **BNC 1** is routed directly to **BNC 3** (without passing through the GPI-100), under the following circumstances: power off, GPI-100 card removed, GPI-100 **Bypass** push-button out, software selection or certain major error conditions.

## SDI Monitor Out — BNC 2

When the GPI-100 is active, **BNC 2** carries a copy of the SDI output present on **BNC 3**. This can be useful for test purposes. **BNC 2** does not have any bypass capability: with power off or the GPI-100 removed, there is no output signal on this jack.

## SDI OSD Out — BNC 5 or BNC 6

**BNC 5** (**BNC 6** on the MDL-R10) carries an SDI (SMPTE 259) video signal that can be connected to an SDI video monitor for setup of operating parameters, in conjunction with the GPI-100's **Menu** switch (**SW2**).

## GPIO Inputs/Outputs

GPIOs 1-8 are inputs to the GPI-100 when used to encode GPIO triggers into the VANC. These jacks are outputs when GPIO triggers are decoded from the VANC. Refer to **Figure 2.4** for MDL-R10 pinouts and **Figure 2.5** for MDL-R20 pinouts.

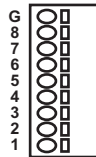

**Figure 2.4** GPIO Pinouts for the MDL-R10    **Figure 2.5** GPIO Pinouts for the MDL-R20

---

# Software Upgrades

This section provides instructions for upgrading the software for your GPI-100 using the DashBoard Control System™.

Use the following procedure to upgrade the software on a GPI-100:

1. Contact Ross Technical Support for the latest software version file.
2. Launch the DashBoard client on your computer.
3. Display a tab for the card you wish to upgrade by double-clicking its status indicator in the **Basic Tree View**.
4. From the **Device** tab, click **Upload** to display the **Select File for upload** dialog box.
5. Navigate to the **\*.bin** upload file you wish to upload.
6. Click **Open** and follow the on-screen instructions.
7. Click **Finish** to start the upgrade.
8. Monitor the upgrade.
  - A **Upload Status** dialog enables you to monitor the upgrade process.
  - The card reboots automatically once the file is uploaded. The card is temporarily taken offline.
  - The reboot process is complete once the status indicators for the **Card State** and **Connection** return to their previous status.



**Operating Tip** — *If you are running DashBoard version 2.3.0 or lower, you must click **Reboot** in the **Device** tab to complete the upgrade process.*

---

This completes the procedure for upgrading the software on a GPI-100.

## Troubleshooting

If you encounter problems when upgrading your card software, verify the following:

- Ethernet cable is properly connected if you are uploading the file via a network connection.
- The file you are attempting to load is a **\*.bin** file that is for the card you are upgrading.



# User Controls

---

## In This Chapter

This chapter provides a general overview of the user controls available on the GPI-100.

The following topics are discussed:

- Card Overview
- Control and Monitoring Features

---

## Card Overview

This section provides a general overview of the GPI-100 card components.

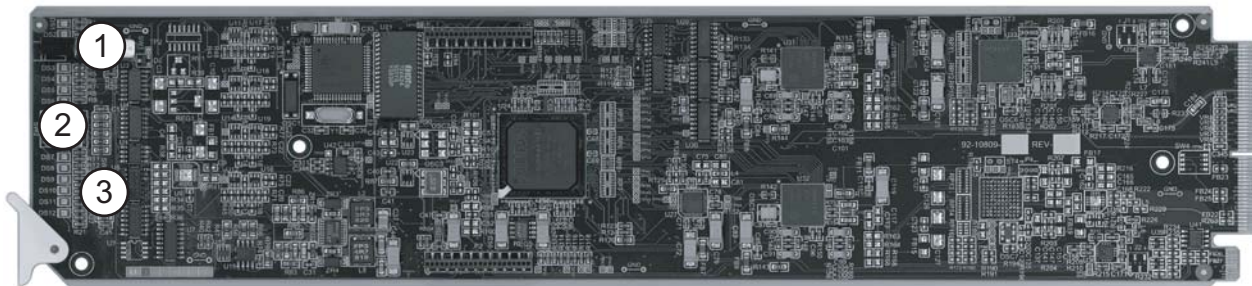

**Figure 3.1** GPI-100 — Components

1) Bypass Switch (SW1)	2) Menu Switch (SW2)	3) Reset Switch (SW3)
------------------------	----------------------	-----------------------

### 1. Bypass Switch (SW1)

If the GPI-100 is installed in the **MDL-R20** rear module, this two-position push-button can be used to control the relay.

- When the push-button is in the **IN** position, the GPI-100 is in the video signal path.
- Pressing it once moves the switch to the **OUT** position and bypasses the GPI-100.
- Pressing it again restores the GPI-100 to its active state.

### 2. Menu Switch (SW2)

The recommended user interface for the GPI-100 is the DashBoard program, running on a computer connected to the openGear frame through an Ethernet connection. If your frame does not have the LAN option, or you do not have access to a computer with DashBoard, you can use the on-screen display (OSD) in conjunction with the Menu Switch. This requires either an SDI or analog monitor (NSTC or PAL) to be connected to the GPI-100. The Menu Switch is a five-direction square finger joystick located near the front card-edge.

For details on the use of the Menu Switch and OSD, refer to the chapter “**Using the On-Screen Menus**” on page 5-1.

### 3. Reset Switch (SW3)

This button is used for rebooting the card. Refer to the section “**Reset Button**” on page 7-2 for details.

#### **For More Information...**

- on the LEDs available on the card-edge, refer to the section “**Control and Monitoring Features**” on page 3-3.

## Control and Monitoring Features

This section provides information on the card-edge LEDs for the GPI-100. Refer to **Figure 3.2** for the location of the LEDs.

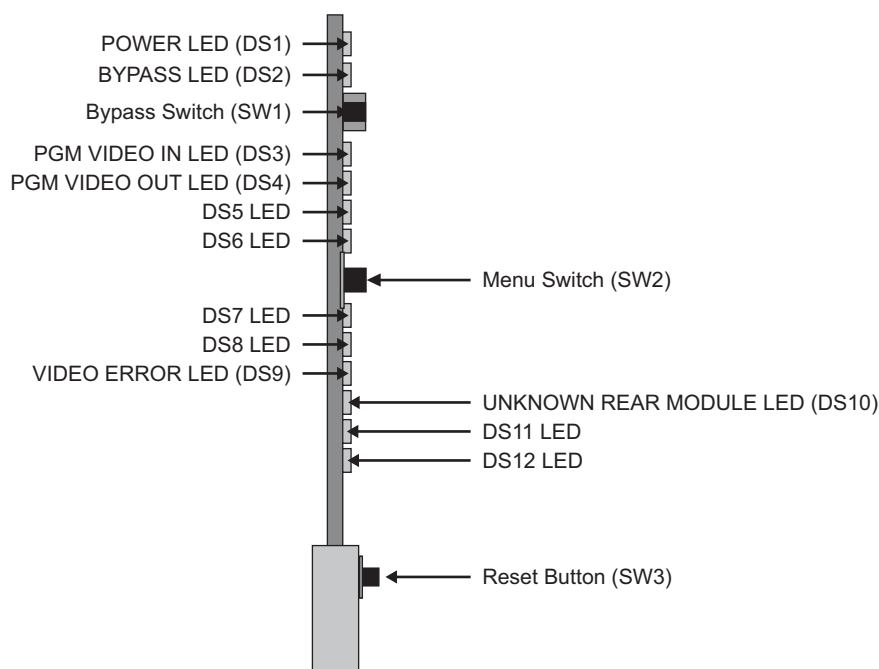

**Figure 3.2** GPI-100 Card-edge Controls

### Status and Selection LEDs on the GPI-100

The front-edge of the GPI-100 has LED indicators for communication activity. Basic LED displays and descriptions are provided in **Table 3.1**.

**Table 3.1** LEDs on the GPI-100

LED	Color	Display and Description
<b>POWER (DS1)</b>	Green	When lit green, this LED indicates that the card is running with a valid input.
	Flashing Green	When flashing green, this LED indicates that the bootloader is waiting for a software upload.
	Yellow	When lit yellow, this LED indicates there is a warning for a signal or a configuration error is occurring.
	Red	When lit red, this LED indicates that the card is not operational. This will occur if, for example, there is not video input.
	Off	When off, this LED indicates that there is no power.
<b>BYPASS (DS2)</b>	Red	When lit red, the GPI-100's video is bypassed.
	Off	When off, this LED indicates that the GPI-100 is in the video path and is capable of inserting data.
<b>PGM VID IN (DS3)</b>	Green	When lit green, the Program Video input is present and valid.
	Red	When lit red, no valid input is present. This typically means that the input cable is disconnected.

**Table 3.1 LEDs on the GPI-100**

LED	Color	Display and Description
<b>PGM VID OUT (DS4)</b>	Green	When lit green, the Program Video output serializer is locked to a valid input.
	Red	When lit red, there is a hardware fault on the card.
<b>DS5</b>		This LED is not implemented.
<b>DS6</b>		This LED is not implemented.
<b>DS7</b>		This LED is not implemented.
<b>DS8</b>		This LED is not implemented.
<b>VIDEO ERROR (DS9)</b>	Green	When lit green, this LED indicates no video errors are occurring.
	Orange	When lit orange, this LED indicates that there has been an error (e.g. EDH) in the video input stream
<b>UNKNOWN REAR MODULE (DS10)</b>	Green	When lit green, this LED indicates a supported rear module is installed with the card.
	Orange	When lit orange, this LED indicates this indicates that the rear module connected to the GPI-100 is not one of the types recognized by the software. Operation may not be correct.
<b>DS11</b>		This LED is not implemented.
<b>DS12</b>		This LED is not implemented.

# Configuration

---

## In This Chapter

This chapter explains how to use the user interface to set up the GPI-100. This discussion is based on the use of DashBoard through a network connection. The order of sections in this chapter follows the workflow required to set up the GPI-100 for operation. It is recommended that you proceed through the following sections in order to achieve the best possible understanding of the product.

The following topics are discussed:

- General Settings
- Configuring GPIOs
- Setting the Logging Timestamp
- Downloading Log Files
- Monitoring

---

# General Settings

This section provides a summary of the initial tasks you may wish to perform before configuring your card for monitoring VANC data. Before proceeding to any of the other sections, please ensure that these settings are correct, as they will have an effect on the operation of the other functions.

## To configure the general settings

1. Select the **Settings** tab.
2. Type a unique name for your card in the **Card ID** field. This is especially useful if you have more than one GPI-100 in a frame. You may also want to add “Encode” or “Decode” to the name. If this field is blank, the name is just “GPI-100”.
3. Use the **Card Function** to determine if the card will be used to encode (**Encode**) triggers into the VANC or decode (**Decode**) triggers from the VANC.
4. Use the **Originator** field to specify a unique value to represent the code that protects against GPIOs from other originators being detected.
5. Use the **DID** and **SDID** fields to specify the VANC address used to encoded and decode the triggers. The default address is 84/2 decimal (54/02 hex). This should not be changed unless it conflicts with existing VANC data. If you need to change it, please set the same address in encoders and decoders.
6. If required, configure the Heads-up Display as follows:
  - Set the **OSD Video Type** to suit your picture monitor.
  - The **OSD Background Color** is normally black, but other selections are available for your convenience. If the video input is a standard definition SMPTE 259 signal (480i 59.94 or 576i 50), you can select Overlay as the background color. This causes the menus to be keyed over the video background. If you select Overlay when the video input is HD or absent, the background is black.
7. If you selected **Encode** in step 3., set **Encode Line** and the **Encode Channel** values. These settings are ignored for the Decode Card Function and the card will look for the triggers on any valid line and channel combination.
8. Click **Accept** to apply the changes.
9. You can save the **Configuration** of the card to a file on a PC by clicking **Save**.
10. The Factory Defaults **Reset** button clears all configuration settings and restores the settings to as they were shipped from the factory.

---

# Configuring GPIOs

The GPI-100 has eight GPIOs connections on the rear module. The **GPIO Mask** tab controls which of the eight are active. The GPI-100 will only generate triggers for enabled GPIOs in encode mode and will ignore changes in the GPIO state of unchecked GPIOs. While decoding triggers from the VANC, the GPI-100 will only drive GPIOs that are enabled. It is therefore possible to have the encode card generate triggers that the decode card will not react to. For example, an encode card could generate GPIO1 and GPIO2 at different times. A decode card could be set to respond to GPIO1 while another card responds to GPIO2.

## About GPIO Polarities

Connecting a GPIO input on the encoding GPI-100 to ground (i.e. a Closed switch) causes a Low logic level. A decoding GPI-100 will faithfully reflect this Low logic level on the corresponding GPIO output. An Open input on the encoder is a High logic level, which will produce a High at the output of a decoding GPI-100. In summary, the GPIO output state of the decoder is identical to the GPIO input state of the encoder.

## Monitoring the GPIO Status

The **GPIO Status** tab reports the status of each of the inputs/outputs as either **Low** or **High**.

## To configure a GPIO to be active

1. Select the **GPIO Mask** tab.

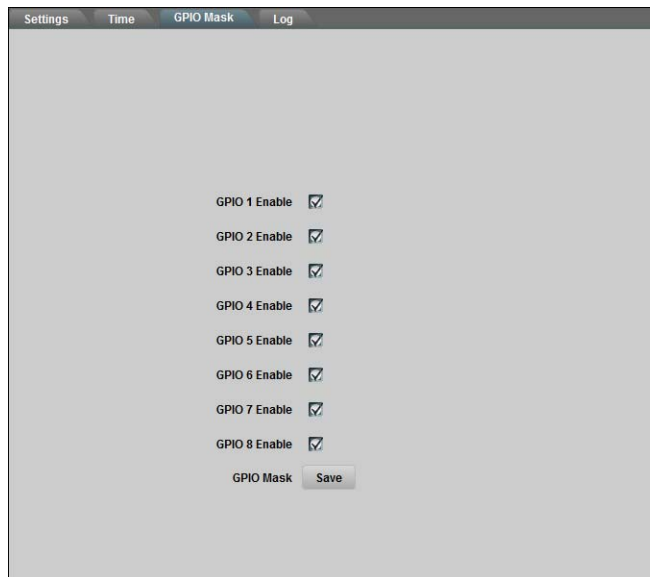

*GPIO Mask Tab*

2. From the provided list, select the box(es) for the GPIOs you wish to enable.
3. Click **Save** to apply the changes.

---

## Setting the Logging Timestamp

The GPI-100 logs any changes of the GPIO state for both the encode and decode cards. For the timestamp to be valid, you must have the time set on the GPI-100. There are three possible methods for setting the time; network time server, timecode or manually.

### To set the logging timestamp

1. Select the **Time** tab.

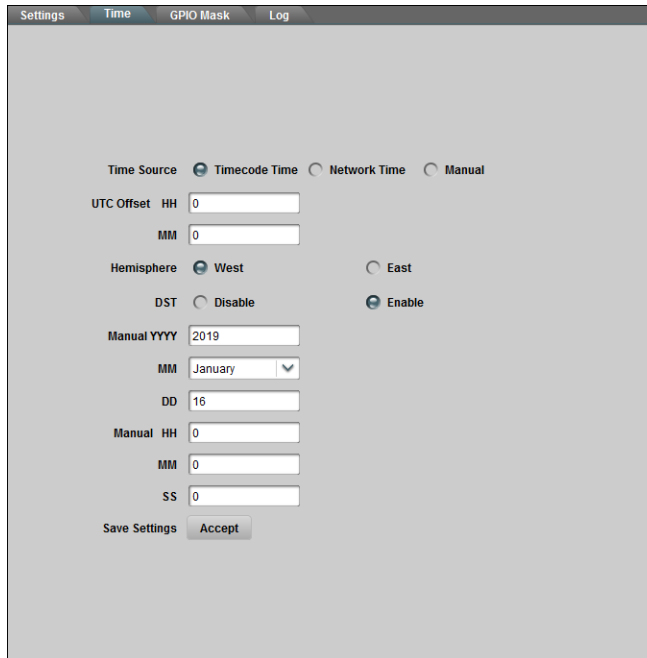
The screenshot shows the 'Time' configuration tab in a software interface. At the top, there are four tabs: 'Settings', 'Time', 'GPIO Mask', and 'Log'. The 'Time' tab is active. Below the tabs, there are three radio buttons for 'Time Source': 'Timecode Time' (selected), 'Network Time', and 'Manual'. Under 'Timecode Time', there are two input fields for 'UTC Offset': 'HH' (0) and 'MM' (0). Below that are two radio buttons for 'Hemisphere': 'West' (selected) and 'East'. Under 'Hemisphere', there are two radio buttons for 'DST': 'Disable' and 'Enable' (selected). Below 'DST', there are three input fields for 'Manual' time: 'YYYY' (2019), 'MM' (January), and 'DD' (16). Below that are three more input fields for 'Manual' time: 'HH' (0), 'MM' (0), and 'SS' (0). At the bottom left, there is a 'Save Settings' label and an 'Accept' button.

*Time Tab*

2. To enable the card to read the time from the VANC data:
  - Select **Timecode Time** from the **Time Source** area.
  - Use the **Manual** fields to specify the month day and year if it's not present in the incoming timecode. If multiple copies of timecode are present in the signal, the GPI-100 uses the last one received.
3. To enable the card to read the time from an NTP server:
  - Ensure that the Network Controller card in the openGear frame has been configured for NTP communication. Refer to the *MFC-8300 Series User Manual* for details.
  - Select **Network Time** from the **Time Source** area.
  - Use the **UTC Offset** field to specify your time offset from Universal Time (UTC), as a positive number of hours and minutes.
  - Use the **Hemisphere** field to specify a direction (West or East). For example, the area of North America where Pacific time is observed is 8 hours west of longitude 0; the settings would be UTC Offset: HH=8, MM = 0 and Hemisphere = West. Note that UTC is also known as GMT (Greenwich Mean Time).
  - Enable or disable **DST** (Daylight Savings Time) as appropriate.
4. To manually specify the time:
  - Use the fields in the **Manual** area to enter the time and date.
5. Click **Accept** to apply the changes.

---

## Downloading Log Files

The **Log** tab shows the last 20 trigger events. An event occurs any time there is a change to any of the GPIOs that are currently enabled. It is logged when a GPIO goes high and also logged when it returns to low. Each log entry is time-stamped with the date and time. The first two characters in each log entry are a hexadecimal representation of the state of the 8 GPIOs. GPIO 1 is the least significant bit and GPIO 8 is the most significant bit. The GPI-100 log is much larger than can be displayed on the Dashboard interface, so there is an option to download the log entries to a text file on your PC. The logfile can be viewed in most text editors.

### To download the log file

1. Select the **Log** tab.
2. Click **Save** to display a dialog box to select a filename for the saved log on the PC.
3. Navigate to the folder you wish to save the logfile to.
4. Click **Save** to move a copy of the logfile to the PC.

---

# Monitoring

The GPI-100 has several alarms that can affect the overall status of the card. This section outlines the three status tabs for the GPI-100. These Status tabs provide read-only information to help monitor the GPI-100 via DashBoard. The indicators in the Status tabs can vary in severity from green (valid) to red (alarm). DashBoard reports the most severe alarm for a single field.

## Product Status

The **Product** tab provides read-only information, such as board revision, serial number, and rear module type. This information is helpful to a Ross Video technical support when there are questions about the operation of the unit.

## GPIO Status Tab

The **GPIO Status** tab reports the status of the eight GPIO inputs/outputs. The status of each of the inputs/outputs is either Open or Closed where Open means logic level 1 (3.3V) and Closed means logic level 0 (0V).

The following fields are displayed in the **GPIO Status** tab:

- **Card Status** — This field reports if the GPIO connection are valid (green), or if no video source or unsupported rear module is connected.
- **Incoming ASI** — This field reports the length and speed of the packet.
- **Bypass State** — This field reports if the card is in Active or Bypass mode (based on how SW1 is set on the card-edge)
- **GPIO #** — This field reports the state of the specified GPIO. The TSI-100 has two active GPIOs. GPIO 1 is active high and GPIO 2 is active low. An active GPIO output produces a switch closure on the rear module.

### *For More Information...*

- on how the GPI-100 uses the VANC to transfer GPIOs from an encode card to a decode card, refer to the section “**Configuring GPIOs**” on page 4-3.

# Using the On-Screen Menus

---

## In This Chapter

This chapter explains how to use the **Menu** switch (**SW3**) functions available on the On-screen Display (OSD) of the GPI-100. It does not describe each available menu; for information on these, refer to the chapter “**Configuration**” on page 4-1. The purpose of this chapter is to explain how to navigate the menus and access the available functions and settings.

The following topics are discussed:

- On-screen Display Overview
- OSD Layout and Navigation
- Using the Menus

---

## On-screen Display Overview

This section briefly describes how to access and navigate through the menus in the on-screen display (OSD). The OSD feature is displayed on a separate composite monitoring output. When activated, the card status and parameters can be viewed and adjusted using the card-mounted menu switch and an easy to use menu system.

### *For More Information...*

- on the switch locations on the card-edge, refer to the section “**Card Overview**” on page 3-2.

## OSD Switch Overview

The **Menu** switch is used to navigate the GPI-100 menu system and configure item parameters. This switch is a five-direction, square, finger joystick.

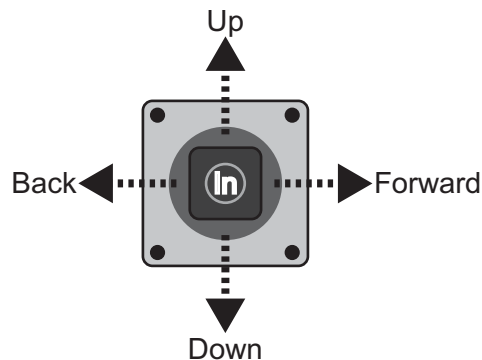

**Figure 5.1** Menu Switch

With the card-edge facing you, use the following menu switch actions and **Figure 5.1** to navigate the menu parameters:

- **In** — pressing once brings the menu system onto the monitor output, holding for two seconds exits the menu system. This position is also used to enter the menu values and parameters.
- **Up** — pressing once selects the menu, item, or value *above* the current selection, holding scrolls to the top of the available selections.
- **Down** — pressing once selects the menu, item, or value *below* the current selection, holding scrolls to the bottom of the available selections.
- **Forward** — pressing once moves from menu to item, or item to value.
- **Back** — pressing once moves from value to item, or item to menu.

---

# OSD Layout and Navigation

A menu, similar shown below, is displayed on the OSD output.

GPI-100 GPIO VANC Encoder		
Product	Settings	EXIT
Product GPI-310		
Manufacturer		
Hardware Rev	A	
Software Rev	A	
Firmware Rev	B	
Rear Module	40	
Current (mA)	400	
Serial Number	N/A	
Current Time	20:37:12	
Current Date	2011/06/02	
● OK		Slot 6

Main OSD Screen — Product Status

The top line of the screen has three items (from left to right): Product, Settings, and Exit.

## Product

This is the first in a list of Status screens. To view these screens, press the **Menu** switch **In** to highlight the word Product, then press **Menu** switch **Down** once to view the GPIO Status screen, and **Down** again for the next screen in the sequence. These are the same **Status** fields described in the section “**Configuration**” on page 4-1.

## Settings

This is the first in a list of Setup menus. To view these, press the **Menu** switch **Forward** to advance the selection bar to the word Settings, then press the **Menu** switch **In** to highlight it. Now press the **Menu** switch **Down** once to view the Alarms menu, and **Down** again for the next menu in the sequence. These are the same menus described in the chapter “**Configuration**” on page 4-1.



---

**Note** — While editing numeric fields, Forward and Back allow you to select individual digits, while Up and Down change the value of the selected digit. Numeric entry is completed by pressing the **Menu** switch **In**. This also applies to editing alphanumeric values in the **Edit Strings** menu.

---

## Exit

To turn off the OSD: press the **Menu** switch **Forward** to advance the selection bar to the word **Exit**, then press the **Menu** switch **In**.

To turn the OSD back on, press the **Menu** switch **In** again. This selection is somewhat redundant, since you should return the front OSD switch to the “in” position anyway to turn the OSD off.

# Using the Menus

The available menus that can be selected via the OSD are described in **Table 5.1**.

**Table 5.1 Available Menus**

Status (left column)	Setup Menu (center column)	Exit (right)
Product	Settings	Exit
GPIO Status	Time	
	GPIO Mask	
	Log	

The use of the menus to change settings will be illustrated by the following example:

1. Navigate to the **Setup Menu** entry on the top row, as discussed previously, by using the **Forward** and **Back** positions of the **Menu** switch.
2. If the **Menu** name (for example, **Settings**) is highlighted (brighter than other text), skip to step 3. If it is not highlighted, press the **Menu** switch **In** to highlight it.
3. Press the **Menu** Switch **Down** or **Up** to step through the available menus.
4. When you reach **Settings**, select it by pressing the **Menu** switch **In**. The display should be similar to the one shown below.

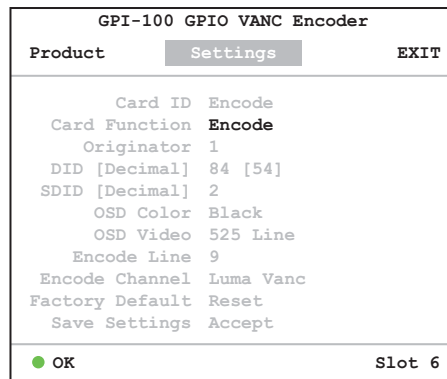

*OSD Settings Menu*

5. Press the **Menu** switch **Down** or **Up** to step through the available items that you can set on this menu.
6. When you reach the **OSD Color** item, select it by pressing the **Menu** switch **In**.
7. Press the **Menu** switch **Down** or **Up** to step through the available values for this item. Note that the background color changes at each step.
8. When you reach the **Card Function** item, select it by pressing the **Menu** switch **In**.
9. Press the **Menu** switch **Down** or **Up** to step through the available values for this item.
10. When you reach the desired value (e.g. Encode), select it by pressing the **Menu** switch **In**.
11. Repeat steps step 5. to step 10. to select values for other items in this menu.
12. To switch to a different menu: press the **Menu** switch **Up** or **Down** repeatedly until the selection bar moves to the title. Press the **Menu** switch **In**. Return to step 3.

# Specifications

---

## In This Chapter

This chapter provides the technical specification information for the GPI-100. Note that technical specifications are subject to change without notice.

The following topics are discussed:

- Technical Specifications

# Technical Specifications

This section provides technical specifications for the GPI-100.

**Table 6.1 GPI-100 Technical Specifications**

Category	Parameter	Specification
SDI Inputs	Number of Inputs	1 Program input
	Data Rates and SMPTE Standards Accommodated	480i 59.94 (SMPTE 259M)
		576i 50 (SMPTE 259M)
		1080i 50, 59.94, 60 (SMPTE 292M)
		720p 50, 59.94, 60 (SMPTE 292M)
		1080p 23.98, 24 (SMPTE 292M)
		1080psf 23.98, 24 (SMPTE 292M)
	Impedance	75ohm terminating in Active mode
		Loop-through to SDI Output in Bypass mode
	Equalization	> 100m of Belden 1694A cable @ 1.485Gbps
400m of Belden 1694A cable @ 270Mbps		
Return Loss	>13dB to 1.485GHz	
SDI Outputs	Number of Outputs	1 Program output
		1 output monitor
		1 on-screen display (OSD) 259M output
	Impedance	75ohm
	Return Loss	>10dB to 1.485GHz
	Signal Level	800mV $\pm$ 10%
	DC Offset	0V $\pm$ 50mV
	Rise & Fall Time (20-80%)	700ps typical (270Mbps)
120ps typical (1.485Gbps)		
Overshoot	<8%	
<b>GPIO Inputs and Outputs</b>	Number of Signals and type	3.3v CMOS logic levels (8 inputs or 8 outputs)
<b>Power</b>	Max. Power Consumption	5W

# Service Information

---

## In This Chapter

This chapter contains the following sections:

- Troubleshooting Checklist
- Warranty and Repair Policy

---

# Troubleshooting Checklist

Routine maintenance to this openGear product is not required. In the event of problems with your GPI-100, the following basic troubleshooting checklist may help identify the source of the problem. If the frame still does not appear to be working properly after checking all possible causes, please contact your openGear products distributor, or the Technical Support department at the numbers listed under the “**Contact Us**” section.

1. **Visual Review** — Performing a quick visual check may reveal many problems, such as connectors not properly seated or loose cables. Check the card, the frame, and any associated peripheral equipment for signs of trouble.
2. **Power Check** — Check the power indicator LED on the distribution frame front panel for the presence of power. If the power LED is not illuminated, verify that the power cable is connected to a power source and that power is available at the power main. Confirm that the power supplies are fully seated in their slots. If the power LED is still not illuminated, replace the power supply with one that is verified to work.
3. **Re-seat the Card in the Frame** — Eject the card and re-insert it into the frame.
4. **Check Control Settings** — Refer to the Installation and User Controls sections of this manual to verify all user-adjustable component settings
5. **Input Signal Status** — Verify that source equipment is operating correctly and that a valid signal is being supplied.
6. **Output Signal Path** — Verify that destination equipment is operating correctly and receiving a valid signal.
7. **Unit Exchange** — Exchanging a suspect unit with a unit that is known to be working correctly is an efficient method for localizing problems to individual units.

## Reset Button

In the unlikely event of a complete card failure, you may be instructed by a Ross Technical Support specialist to perform a complete software reload on the GPI-100.

Use the following procedure to reload the software on a GPI-100:

1. Press and hold the **Menu** switch.
2. While holding the **Menu** switch, press the **Reset** button.
3. Release the **Reset** button and then the **Menu** switch.
  - The **POWER LED** (DS1) will flash green while the card is waiting for a new software load.
  - If a new software load is not sent to the card within 60 seconds, the card will attempt to restart with its last operational software load.
  - Software loads can be sent to the GPI-100 via the connection on the rear of the frame.

This completes the procedure for reload the software on a GPI-100.

---

## Warranty and Repair Policy

The GPI-100 is warranted to be free of any defect with respect to performance, quality, reliability, and workmanship for a period of FIVE (5) years from the date of shipment from our factory. In the event that your GPI-100 proves to be defective in any way during this warranty period, Ross Video Limited reserves the right to repair or replace this piece of equipment with a unit of equal or superior performance characteristics.

Should you find that this GPI-100 has failed after your warranty period has expired, we will repair your defective product should suitable replacement components be available. You, the owner, will bear any labor and/or part costs incurred in the repair or refurbishment of said equipment beyond the FIVE (5) year warranty period.

In no event shall Ross Video Limited be liable for direct, indirect, special, incidental, or consequential damages (including loss of profits) incurred by the use of this product. Implied warranties are expressly limited to the duration of this warranty.

This GPI-100 User Manual provides all pertinent information for the safe installation and operation of your openGear Product. Ross Video policy dictates that all repairs to the GPI-100 are to be conducted only by an authorized Ross Video Limited factory representative. Therefore, any unauthorized attempt to repair this product, by anyone other than an authorized Ross Video Limited factory representative, will automatically void the warranty. Please contact Ross Video Technical Support for more information.

### In Case of Problems

Should any problem arise with your GPI-100, please contact the Ross Video Technical Support Department. (Contact information is supplied at the end of this publication.)

A Return Material Authorization number (RMA) will be issued to you, as well as specific shipping instructions, should you wish our factory to repair your GPI-100. If required, a temporary replacement frame will be made available at a nominal charge. Any shipping costs incurred will be the responsibility of you, the customer. All products shipped to you from Ross Video Limited will be shipped collect.

The Ross Video Technical Support Department will continue to provide advice on any product manufactured by Ross Video Limited, beyond the warranty period without charge, for the life of the equipment.

# Contact Us

Contact our friendly and professional support representatives for the following:

- Name and address of your local dealer
- Product information and pricing
- Technical support
- Upcoming trade show information

## Technical Support

Telephone: +1 613 • 652 • 4886  
After Hours Emergency: +1 613 • 349 • 0006  
Email: [techsupport@rossvideo.com](mailto:techsupport@rossvideo.com)

## General Information

Telephone: +1 613 • 652 • 4886  
Fax: +1 613 • 652 • 4425  
Email: [solutions@rossvideo.com](mailto:solutions@rossvideo.com)  
Website: <http://www.rossvideo.com>

## Visit Us

Visit our website for:

- Company information and news
- Related products and full product lines
- Online catalog
- Testimonials