

ADC-8732B (-S, -C)
Analog Composite to SD-SDI Video Decoder
User Manual

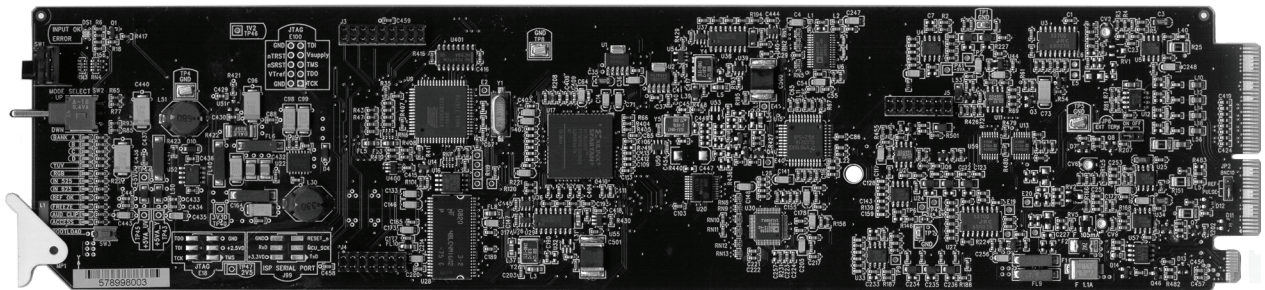

8732BDR-004-02A • ADC-8732B Analog Composite to SD-SDI Video Decoder User Manual

- Ross Part Number: **8732BDR-004-02A**
- Release Date: December 2, 2009. Printed in Canada.

The information contained in this manual is subject to change without notice or obligation.

Copyright

© 2009 Ross Video Limited. All rights reserved.

Contents of this publication may not be reproduced in any form without the written permission of Ross Video Limited. Reproduction or reverse engineering of copyrighted software is prohibited.



Patents

This product is protected by the following US Patents: 4,205,346; 5,115,314; 5,280,346; 5,561,404; 7,034,886; 7,508,455. This product is protected by the following Canadian Patents: 2039277; 1237518; 1127289. Other patents pending.

Notice

The material in this manual is furnished for informational use only. It is subject to change without notice and should not be construed as commitment by Ross Video Limited. Ross Video Limited assumes no responsibility or liability for errors or inaccuracies that may appear in this manual.

Trademarks

-  is a registered trademark of Ross Video Limited.
-  is a trademark of Ross Video Limited.
- Ross, ROSS, ROSS® are registered trademarks of Ross Video Limited.
- DashBoard Control System™ is a trademark of Ross Video Limited.
- All other product names and any registered and unregistered trademarks mentioned in this guide are used for identification purposes only and remain the exclusive property of their respective owners.

Important Regulatory and Safety Notices

Before using this product and any associated equipment, refer to the “**Important Safety Instructions**” listed below to avoid personnel injury and to prevent product damage.

Products may require specific equipment, and/or installation procedures to be carried out to satisfy certain regulatory compliance requirements. Notices have been included in this publication to call attention to these specific requirements.

Symbol Meanings



This symbol on the equipment refers you to important operating and maintenance (servicing) instructions within the Product Manual Documentation. Failure to heed this information may present a major risk of damage or injury to persons or equipment.



Warning — The symbol with the word “**Warning**” within the equipment manual indicates a potentially hazardous situation which, if not avoided, could result in death or serious injury.



Caution — The symbol with the word “**Caution**” within the equipment manual indicates a potentially hazardous situation which, if not avoided, may result in minor or moderate injury. It may also be used to alert against unsafe practices.



Notice — The symbol with the word “**Notice**” within the equipment manual indicates a situation, which if not avoided, may result in major or minor equipment damage or a situation which could place the equipment in a non-compliant operating state.



ESD Susceptibility — This symbol is used to alert the user that an electrical or electronic device or assembly is susceptible to damage from an ESD event.

Important Safety Instructions



Caution — This product is intended to be a component product of the DFR-8300 series frame. Refer to the DFR-8300 series frame User Manual for important safety instructions regarding the proper installation and safe operation of the frame as well as its component products.



Warning — Certain parts of this equipment namely the power supply area still present a safety hazard, with the power switch in the OFF position. To avoid electrical shock, disconnect all A/C power cards from the chassis’ rear appliance connectors before servicing this area.



Warning — Service barriers within this product are intended to protect the operator and service personnel from hazardous voltages. For continued safety, replace all barriers after any servicing.
This product contains safety critical parts, which if incorrectly replaced may present a risk of fire or electrical shock. Components contained with the product’s power supplies and power supply area, are not intended to be customer serviced and should be returned to the factory for repair. To reduce the risk of fire, replacement fuses must be the same time and rating. Only use attachments/accessories specified by the manufacturer.

EMC Notices

United States of America FCC Part 15

This equipment has been tested and found to comply with the limits for a class A Digital device, pursuant to part 15 of the FCC Rules. These limits are designed to provide reasonable protection against harmful interference when the equipment is operated in a commercial environment. This equipment generates, uses, and can radiate radio frequency energy and, if not installed and used in accordance with the instruction manual, may cause harmful interference to radio communications. Operation of this equipment in a residential area is likely to cause harmful interference in which case the user will be required to correct the interference at his own expense.



Notice — *Changes or modifications to this equipment not expressly approved by Ross Video Limited could void the user's authority to operate this equipment.*

CANADA

This Class "A" digital apparatus complies with Canadian ICES-003.

Cet appareil numérique de la classe "A" est conforme à la norme NMB-003 du Canada.

EUROPE

This equipment is in compliance with the essential requirements and other relevant provisions of **CE Directive 93/68/EEC**.

INTERNATIONAL

This equipment has been tested to **CISPR 22:1997** along with amendments **A1:2000** and **A2:2002**, and found to comply with the limits for a Class A Digital device.



Notice — *This is a Class A product. In domestic environments, this product may cause radio interference, in which case the user may have to take adequate measures.*

Maintenance/User Serviceable Parts

Routine maintenance to this openGear product is not required. This product contains no user serviceable parts. If the module does not appear to be working properly, please contact Technical Support using the numbers listed under the "Contact Us" section on the last page of this manual. All openGear products are covered by a generous 5-year warranty and will be repaired without charge for materials or labor within this period. See the "Warranty and Repair Policy" section in this manual for details.

Environmental Information

The equipment that you purchased required the extraction and use of natural resources for its production. It may contain hazardous substances that could impact health and the environment.

To avoid the potential release of those substances into the environment and to diminish the need for the extraction of natural resources, Ross Video encourages you to use the appropriate take-back systems. These systems will reuse or recycle most of the materials from your end-of-life equipment in an environmentally friendly and health conscious manner.

The crossed-out wheeled bin symbol invites you to use these systems.

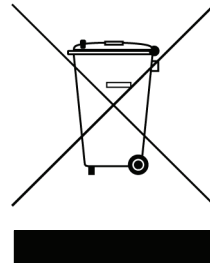

If you need more information on the collection, reuse, and recycling systems, please contact your local or regional waste administration. You can also contact Ross Video for more information on the environmental performances of our products.

Company Address



Ross Video Limited

8 John Street
Iroquois, Ontario
Canada, K0E 1K0

Ross Video Incorporated

P.O. Box 880
Ogdensburg, New York
USA 13669-0880

General Business Office: (+1) 613 • 652 • 4886

Fax: (+1) 613 • 652 • 4425

Technical Support: (+1) 613 • 652 • 4886

After Hours Emergency: (+1) 613 • 349 • 0006

E-mail (Technical Support): techsupport@rossvideo.com

E-mail (General Information): solutions@rossvideo.com

Website: <http://www.rossvideo.com>



Contents

Introduction	1
Overview.....	1-2
Features.....	1-3
Functional Block Diagram.....	1-4
Documentation Terms and Conventions.....	1-5
Installation	2
Before You Begin	2-2
Static Discharge.....	2-2
Unpacking.....	2-2
Installing the ADC-8732B	2-3
Rear Modules for the DFR-8310 Series Frames	2-3
Rear Modules for the DFR-8321 Series Frames	2-3
Installing a Rear Module	2-3
Installing the ADC-8732B.....	2-4
Cabling for the ADC-8732B.....	2-5
DFR-8310 Series Frame Cabling Overview.....	2-5
DFR-8321 Series Frame Cabling Overview.....	2-5
Video Cabling for the ADC-8732B.....	2-6
Audio Cabling for the ADC-8732B	2-7
Software Upgrades for the ADC-8732B.....	2-8
Installing a License Key	2-8
Performing Software Upgrades	2-8
User Controls	3
Card Overview	3-2
Tracking Pulse Output.....	3-3
Control and Monitoring Features.....	3-4
Status and Selection LEDs on the ADC-8732B	3-4
Notes on Timing Modes	3-6
Line Delay Mode.....	3-6
Line Sync Mode	3-6
Frame Delay Mode.....	3-7
Frame Sync Mode.....	3-7
Menus	4
SNMP Monitoring and Control	4-2
DashBoard Menus for the ADC-8732B.....	4-3
Status Menus	4-3
Setup Menus	4-4
Timing Menus	4-5
Output Menus	4-6
Framing Menus.....	4-6
Proc Amp Menus.....	4-7

Audio Menus	4-7
Alarms Menus.....	4-8
Heads-up Display Menus	4-9
Overview.....	4-9
Bank A Menus	4-10
Bank A Menu Parameters	4-11
Bank B Menus	4-12
Bank B Menu Parameters	4-13
Bank C Menus	4-14
Bank C Menu Parameters	4-15
Bank D Menus	4-17
Bank D Menu Parameters	4-18

Specifications **5**

Technical Specifications	5-2
--------------------------------	-----

Service Information **6**

Troubleshooting Checklist	6-2
Bootload Button.....	6-2
Warranty and Repair Policy	6-3

Introduction

In This Chapter

This chapter contains the following sections:

- Overview
- Functional Block Diagram
- Documentation Terms and Conventions

A Word of Thanks

Congratulations on choosing an openGear ADC-8732B Analog Composite to SD-SDI Video Decoder. Your ADC-8732B is part of a full line of Digital Products within the openGear Terminal Equipment family of products, backed by Ross Video's experience in engineering and design expertise since 1974.

You will be pleased at how easily your new ADC-8732B fits into your overall working environment. Equally pleasing is the product quality, reliability and functionality. Thank you for joining the group of worldwide satisfied Ross Video customers!

Should you have a question pertaining to the installation or operation of your ADC-8732B, please contact us at the numbers listed on the back cover of this manual. Our technical support staff is always available for consultation, training, or service.

Overview

The ADC-8732B is a 10-bit broadcast quality video decoder with a 12-bit analog to digital converter. It is specifically designed for broadcast or production situations in which an analog PAL-B, PAL-M, PAL-N, or NTSC composite signal must be converted to a component SD-SDI signal. Seven SD-SDI outputs are provided.

The ADC-8732B fits into the DFR-8300 series frames. Refer to the *DFR-8300 Series Frames User Manual* for specific ventilation and cooling instructions to maintain optimum operating conditions.

The ADC-8732B is available in the following models:

- **ADC-8732B** — The base model decoder includes Proc Amps, Line Delay, and Line Synchronizer modes.
- **ADC-8732B-S** — This model includes a Frame Synchronizer, along with all the features available on the ADC-8732B.
- **ADC-8732B-C** — This model includes the AAM-8581 daughter card and includes four channels of analog audio embedding along with all the features available on the ADC-8732B.
- **ADC-8732B-SC** — This model includes a Frame Synchronizer in addition to all the features available on the ADC-8732B-C and the ADC-8732B.

The complete circuit for the ADC-8732B, including a 12-bit A-D converter, decoder, Line (or frame) synchronizer, serializer, tracking delay pulse, and microprocessor is contained on a single DA-sized card. Additional daughter cards are required for audio embedding.

A 10-bit decoding process provides excellent performance with all types of picture sources. The decoder uses 3-line, 5-line, and adaptive 3D filters with advanced control algorithms.

To simplify configuration, the ADC-8732B offers two methods:

- **DashBoard Control System™** — The ADC-8732B is fully compliant with all openGear technical specifications and supports remote monitoring and control via the DashBoard Control System.
- **Heads-up Display (HUD)** — The ADC-8732B includes an on-screen display that enables you to view adjustments made using the card-edge controls.
- Changes made using either of the above methods are reflected in the other.

ADC-8732B-S Overview

The ADC-8732B model comes with a full featured frame synchronizer, capable of synchronizing incoming video to house reference. Various timing modes are available to accommodate most situations.

ADC-8732B-C Overview

The ADC-8732B-C model includes the ADC-8732B or the ADC-8732B-S, the AAM-8581, and the appropriate rear module. The AAM-8581 is a daughter card that plugs onto the top of the ADC-8732B and enables you to add four channels of analog audio conversion and embedding to the SDI video output of the ADC-8732B. The AAM-8581 uses state of the art analog to digital converters that provide 24-bit resolution. The audio gain adjustment is provided in the analog domain through the use of digital potentiometers and has a range of ± 10 dBu.

Features

The following features make the ADC-8732B the most flexible, high-quality decoding card for your analog to digital conversion requirements:

- 12-bit analog to digital conversion
- 10-bit decoding with 3-line/5-line/3D adaptive comb filters
- Optional Frame Synchronization (no daughter card required)
- Freeze modes
- Horizontal and vertical timing adjustments
- Programmable vertical interval blanking
- Setup adjustment
- Black level offset
- Passes Super Black
- Status indicator LEDs on card-edge
- Choice of reference inputs (composite sync only)
- Tracking Delay output for companion audio synchronizer
- Built-in test signals
- Reports status and configuration remotely via the DashBoard Control System™
- Fits DFR-8300 series frames
- Fully compliant with openGear specifications
- 5-year transferable warranty

ADC-8732B-C Features

The following features are also available for the ADC-8732B-C:

- 4 channel audio embedding
- 24-bit ADC resolution
- Selectable maximum input level from -10dBu to +10dBu in 0.5dBu increments
- +/- 0.05dB frequency response 20Hz to 22Hz
- Audio Clip LED on card-edge
- Alarm feature via DashBoard
- Silence alarm with threshold and alarm timeout settings
- Audio Delay up to 5 seconds

Functional Block Diagram

This section provides a functional block diagram that outlines the workflow of the ADC-8732B.

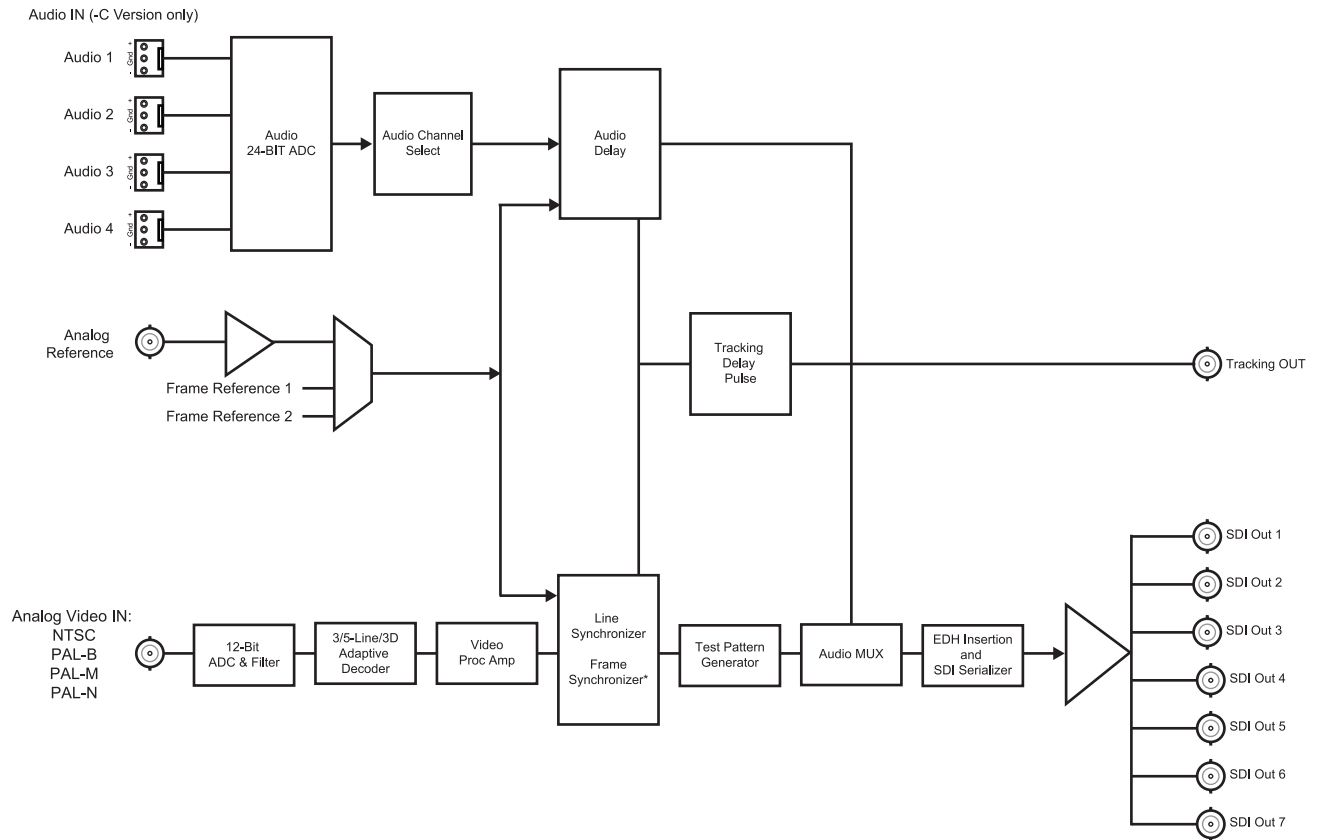

*Available on the ADC-8732B-S and ADC-8732B-SC only

** On the R2S-8732 Split Rear Modules, only SDI Out 2 and 4 are available.

Figure 1.1 ADC-8732B — Simplified Block Diagram

Documentation Terms and Conventions

The following terms and conventions are used throughout this manual:

- “**Frame**” refers to DFR-8300 series frame that houses the ADC-8732B card, as well as any openGear frames.
- All references to the **DFR-8300 series frame** also includes all version of the 10-slot (DFR-8310 series) and 20-slot (DFR-8321 series) frames and any available options unless otherwise noted.
- All references to the **ADC-8732B** also includes all versions unless otherwise indicated.
- “**Operator**” and “**User**” refer to the person who uses ADC-8732B.
- “**Board**”, and “**Card**” refer to openGear terminal devices within openGear frames, including all components and switches.
- “**System**” and “**Video system**” refer to the mix of interconnected production and terminal equipment in your environment.
- “**525-line mode**” refers to broadcast situations using **NTSC** or **PAL-M** composite (analog) signal reference inputs.
- “**625-line mode**” refers to broadcast situations using **PAL-B** or **PAL-N** composite (analog) signal reference inputs.
- “**PAL**” refers to PAL-B, PAL-M, and PAL-N unless otherwise stated.
- The “**Operating Tips**” and “**Note**” boxes are used throughout this manual to provide additional user information.

Installation

In This Chapter

This chapter provides instructions for installing the Rear Module(s) for the ADC-8732B, installing the card into the frame, cabling details, and updating the card software.

The following topics are discussed:

- Before You Begin
- Installing the ADC-8732B
- Cabling for the ADC-8732B
- Software Upgrades for the ADC-8732B

Before You Begin

Before proceeding with the instructions in this chapter, ensure that your DFR-8300 series frame is properly installed according to the instructions in the *DFR-8300 Series User Manual*.

Static Discharge

Throughout this chapter, please heed the following cautionary note:



ESD Susceptibility — *Static discharge can cause serious damage to sensitive semiconductor devices. Avoid handling circuit boards in high static environments such as carpeted areas and when synthetic fiber clothing is worn. Always exercise proper grounding precautions when working on circuit boards and related equipment.*

Unpacking

Unpack each ADC-8732B you received from the shipping container and ensure that all items are included. If any items are missing or damaged, contact your sales representative or Ross Video directly.

Installing the ADC-8732B

This section outlines how to install a Rear Module in a DFR-8300 series frame. The same procedure applies regardless of the frame or card type. However, the specific Rear Module you need to install depends on the frame you are using.



Note — An error message displays in the DashBoard **Hardware Status** field when using the AAM-8581 daughter card with an unsupported Rear Module. The following Rear Modules are not supported by the AAM-8581: 8310AR-030, 8310AR-031, 8320AR-030, 8320AR-031, 8320AR-040, and 8320AR-041.

Rear Modules for the DFR-8310 Series Frames

When installing in the DFR-8310 series frames:

- **ADC-8732B** — The **8310AR-030** Rear Module (R1-8732) is required. The ADC-8732B is also compatible with the DFR-8310-BNC frame.
- **ADC-8732B-C** or **ADC-8732B-SC** — The **8310AR-037** Rear Module (R1C-8732) is required.

Rear Modules for the DFR-8321 Series Frames

When installing in the DFR-8321 series frames:

- **ADC-8732B** — The **8320AR-030** Full Rear Module (R2-8732) or the **8320AR-031** Split Rear Module (R2S-8732) can be used.
- **ADC-8732B-C** or **ADC-8732B-SC** — The **8320AR-031** Full Rear Module (R2C-8732) is required. The ADC-8732B-C and the ADC-8732B-SC are not compatible with the Split Rear Module.

Installing a Rear Module

If you are installing the ADC-8732B in a DFR-8310-BNC frame, or the Rear Module is already installed, proceed to the section “**Installing the ADC-8732B**” on page 2-4.

Use the following procedure to install a Rear Module in your DFR-8300 series frame:

1. Locate the card frame slots on the rear of the frame.



Note — Do not install the ADC-8732B-C or the ADC-8732B-SC in slot 10 of your DFR-8310 series frame when using an MFC-8310-N series Network Controller Card. Doing so may damage the Network Controller Card, the AAM-8581, or both.

2. Remove the Blank Plate from the slot you have chosen for the ADC-8732B installation.
3. Install the bottom of the Rear Module in the **Module Seating Slot** at the base of the frame’s back plane. **Figure 2.1**

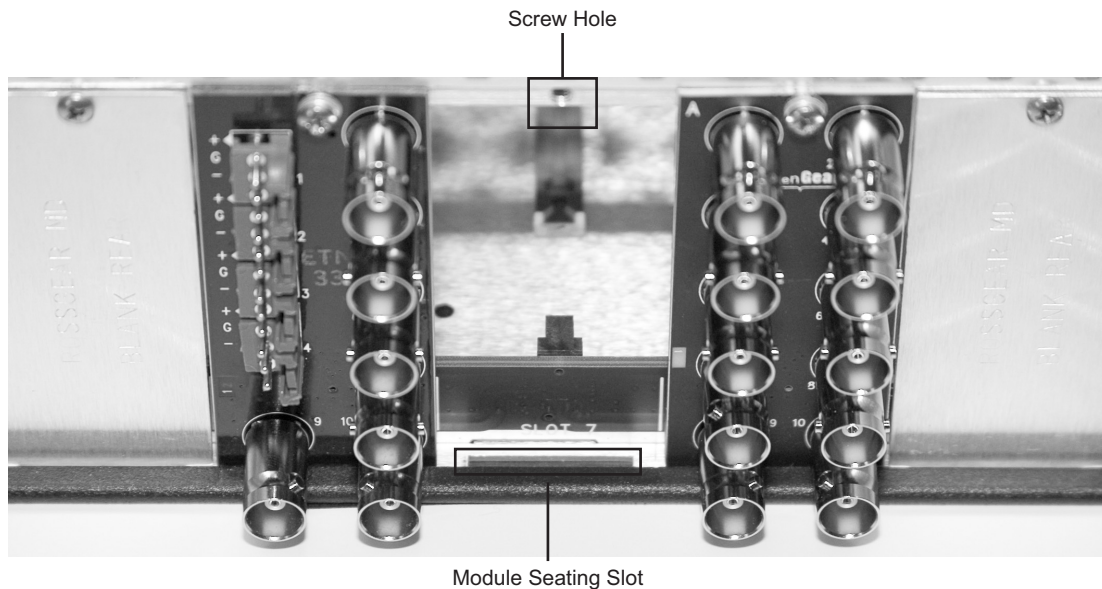

Figure 2.1 Rear Module Installation in a DFR-8310 Series Frame (ADC-8732B not shown)

4. Align the top hole of the Rear Module with the screw on the top-edge of the frame back plane.
5. Using a Phillips screwdriver and the supplied screw, fasten the Rear Module to the back plane of the frame. Do not over tighten.
6. Ensure proper frame cooling and ventilation by having all rear frame slots covered with Rear Modules or Blank Plates.

This completes the procedure for installing a Rear Module in your DFR-8300 series frame.

Installing the ADC-8732B

This section outlines how to install the ADC-8732B in a DFR-8300 series frame. If the ADC-8732B is to be installed in any compatible frame other than a Ross Video product, refer to the frame manufacturer's manual for specific instructions.

Use the following procedure to install the ADC-8732B in a DFR-8300 series frame:

1. Locate the Rear Module you installed in the procedure “**Installing a Rear Module**” on page 2-3.



Notice — Heat and power distribution requirements within a frame may dictate specific slot placements of cards. Cards with many heat-producing components should be arranged to avoid areas of excess heat build-up, particularly in frames using convective cooling.

2. Hold the ADC-8732B by the edges and carefully align the card-edges with the slots in the frame.
3. Fully insert the card into the frame until the rear connection plus is properly seated in the Rear Module.
4. Affix the supplied **Rear Module Label**, as per the included instructions, to the BNC area of the Rear Module.

This completes the procedure for installing the ADC-8732B in a DFR-8300 series frame.

Cabling for the ADC-8732B

This section provides information for connecting cables to the installed Rear Modules on the DFR-8300 series frames. Connect the input and output cables according to the following sections.

DFR-8310 Series Frame Cabling Overview

In the DFR-8310 series frames, the ADC-8732B is used with the following Rear Modules:

- **R1-8732** Rear Module — Each card occupies one slot and provides seven SD-SDI outputs, one tracking pulse output, and a reference input. Cable your ADC-8732B according to **Figure 2.2**.
- **R1C-8732** Rear Module — Each card occupies one slot and provides four audio inputs, three SDI outputs, one tracking pulse output, and a reference output. Cable your ADC-8732B-C or ADC-8732B-SC according to **Figure 2.3**.

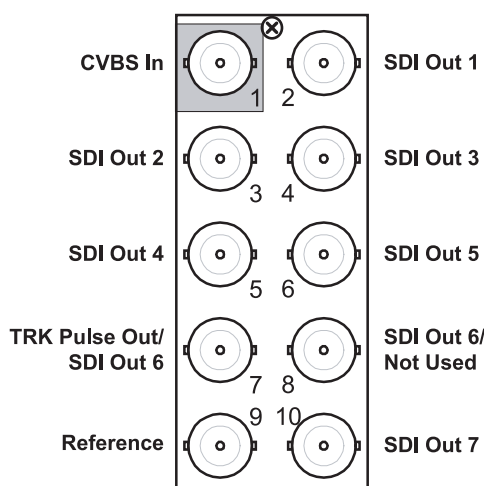

Figure 2.2 Cable Connections for the **R1-8732** and **R2-8732** Rear Modules

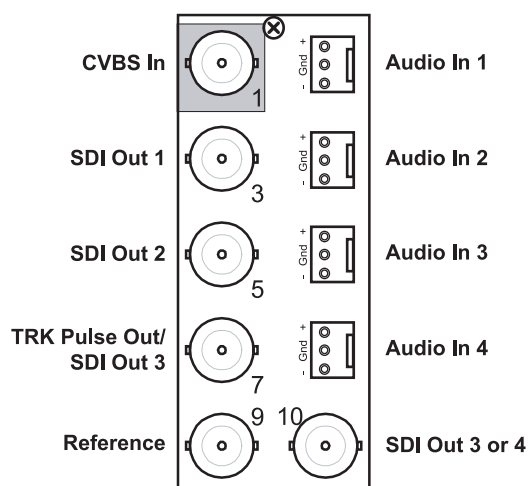

Figure 2.3 Cable Connections for the **R1C-8732** and **R2C-8732** Rear Modules

DFR-8321 Series Frame Cabling Overview

In the DFR-8321 series frames, the ADC-8732B is used with the following Rear Modules:

- **R2-8732** Full Rear Module — Each card occupies two slots and provides seven SD-SDI outputs, one tracking pulse output, and a reference input. Cable your ADC-8732B according to **Figure 2.2**.
- **R2C-8732** Full Rear Module — Each card occupies two slots and provides four audio inputs, three SDI outputs, one tracking pulse output, and a reference output. Cable your ADC-8732B-C or ADC-8732B-SC according to **Figure 2.3**.
- **R2S-8732** Split Rear Module — Each card occupies one slot and provides two or three outputs. Note that each rear module provides connections for two cards. Cable your ADC-8732B according to **Figure 2.4**.

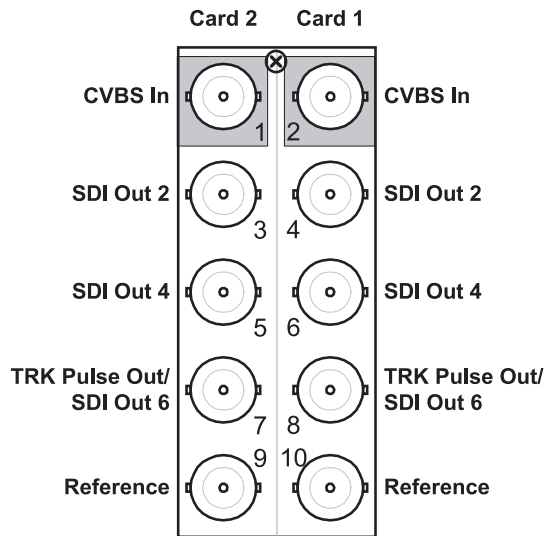

Figure 2.4 Cable Connections for the R2S-8732 Rear Module

Video Cabling for the ADC-8732B

Use the following procedure to cable the ADC-8732B:

1. Connect the input composite signal to BNC 1 (CVBS In). If you are using the R2S-8732 Split Rear Module, BNC 1 or BNC 2 can be used, depending on the positioning of the ADC-8732B in the frame.
2. Connect downstream SD-SDI devices to BNCs 2 through 6, 8, and 10 (SD-SDI Out). If you are using the R2S-8732 Split Rear Module, connect to the required BNCs as indicated in **Figure 2.4**.
3. Connect BNC 7 (TRK Pulse Out) to any device that needs to track the video delay through the ADC-8732B or ADC-8732B-S.
 - The Tracking Pulse is a positive 5V pulse. Its width tracks the video delay as it passes through the card. The ADC-8732B tracking delay pulse tracks up to two video lines, the ADC-8732B-S up to two fields.
 - If you are using the R2S-8732 Split Rear Module, connect to BNC 8 to **JP3** is set to the default.
4. Connect a video reference in one of two ways:
 - Connect to BNC 9 (Reference) on the Rear Module. If you are using the R2S-8732 Split Rear Module, connect to BNC 9 or BNC 10, depending on the positioning of the ADC-8732B in the frame; or
 - Connect to **REF1** or **REF2** on the back of the frame.
5. Specify the reference source using DashBoard or the Heads-Up Display.

This completes the procedure for cabling the ADC-8732B.

Audio Cabling for the ADC-8732B

The R1C-8732 and R2C-8732 Rear Modules provide four audio terminal blocks with removable connectors for Audio In 1, 2, 3, and 4 (refer to **Figure 2.3** for cable designations). Each connector has locations for the positive, negative, and grounded wires of a balanced analog audio cable.

Use the following procedure to wire the analog audio for the R1C-8732 and R2C-8732:

1. Insert an analog audio wire to the designated polarity slot on the connector of the rear module. **Figure 2.5**

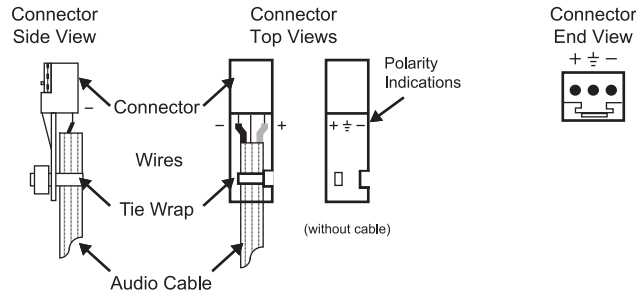

Figure 2.5 Connector Wiring for R1C-8732 and R2C-8732 Input Sockets

2. Use a tweaker screwdriver to tighten the corresponding capture screw.
3. Repeat steps 1 and 2 for each wire on each connector.
4. Once the cables are wired to the connectors, install the connectors on the terminal blocks for the rear module.

This completes the procedure for wire the analog audio for the R1C-8732 and R2C-8732.

Software Upgrades for the ADC-8732B

This section provides instructions for installing a license key and upgrading the software for your ADC-8732B using the DashBoard Control System™.

Installing a License Key

When installing a license key on the ADC-8732B:

- You must have DashBoard installed and communicating with the DFR-8300 series frame that houses the card you wish to install the key for. The DashBoard software and manual are available from the Ross Video website.
- Ensure that you are using version 2.0 or higher of DashBoard. This information is available by selecting **Help** ⇒ **About DashBoard** from the DashBoard main toolbar.

Installing a License Key

Use the following procedure to install a license key for the ADC-8732B using DashBoard:

1. Launch DashBoard on your computer.
2. In Dashboard, display the **Device** tab of the ADC-8732B by double-clicking its status indicator in the **Basic Tree View**.
3. Select the **Setup** tab in the **Device View** to display the setup information.
4. Make a note of the **Request Code** in the License Key field.
5. Contact Ross Video Technical Support using the information found in the section “**Contact Us**”.
 - When you speak to the Technical Support representative, tell them your name, your facility name, and the **Request Code** from the **Setup** tab from step 4.
 - You will be given a License Key that must be entered in the **License** field of the **Setup** tab.
6. Enter the **License Key** in the **License** box of the **Setup** tab.
7. When the installation is complete, verify that the following has occurred:
 - the **Setup** tab displays “**Licensed**” in the **Frame Sync** field.
 - the **Frame Sync** field displays a green background.

This completes the procedure for installing a license key for the ADC-8732B using DashBoard.

Performing Software Upgrades

DashBoard enables you to upload software updates to the ADC-8732B.

Use the following procedure to upload software to the ADC-8732B:

1. Contact Ross Technical Support for the latest software version file.
2. In DashBoard, display the **Device** tab of the ADC-8732B by double-clicking its status indicator in the **Basic Tree View**.
3. From the **Device** tab, click **Upload** to display the **Select File for upload** dialog box.
4. Click **Browse...** to navigate to the *.bin file you wish to upload. DashBoard automatically selects the last directory that you loaded from.

5. Click **Open** to display a confirmation dialog box. This dialog box displays the selected upload file name, type, size, and the file creation date.
6. From the **Confirmation** dialog box, select one of the following:
 - **Cancel** — Select this option to cancel the upload of the file and return to the **Device View**.
 - **Continue** — Select this option to upload the file. While uploading, an **Uploading Progress** dialog box opens.



Important — *Pressing the **Cancel** button while uploading will leave the card in an invalid state. Do not click **Cancel** unless the uploading progress has stopped completely for 60 seconds or more.*

7. Monitor the upgrade progress bar displayed in DashBoard while the software is upgraded on your ADC-8732B.
8. To complete the upgrade process, DashBoard performs an automatic reboot of the card.



Note — *The communications processor of the ADC-8732B requires approximately 30 seconds to re-start and re-establish network communications.*

- The ADC-8732B automatically saves all your settings before starting the reboot process.
- The status of all the cards in the frame are grayed out until the reboot process is complete.

This completes the procedure to upload software to the ADC-8732B.

User Controls

In This Chapter

This chapter provides a general overview of the user controls available on the ADC-8732B.

The following topics are discussed:

- Card Overview
- Control and Monitoring Features
- Notes on Timing Modes

Card Overview

This section provides a general overview of the ADC-8732B components. The configurations outlined in this section should be performed before installing the card in the frame, but may be repeated as required. For information on the LEDs available on the card-edge, refer to the section “Control and Monitoring Features” on page 3-4.

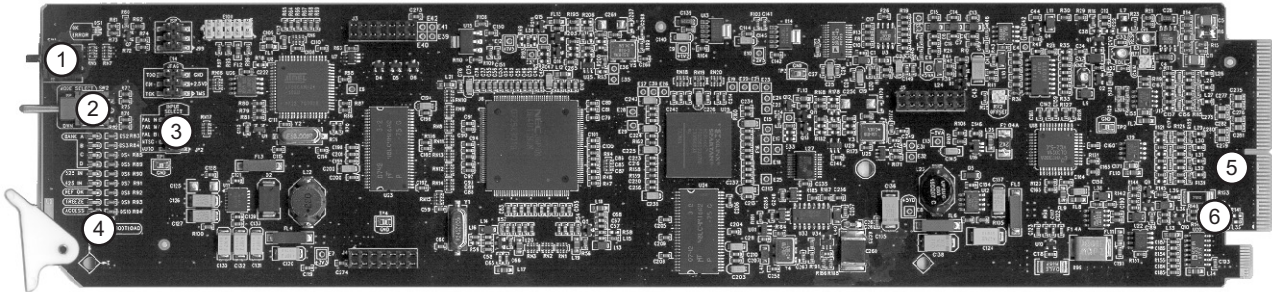

Figure 3.1 ADC-8732B — Components

1) SW1 - Function Select	3) JP2 - Input Select	5) JP3 - BNC 7
2) SW2 - Mode Select	4) SW3 - Bootload Button	6) JP1 - EXT TERM

1. SW1 - Function Select

SW1 is a 16-position rotary switch used to select functions such as Proc Amp controls and timing adjustment menu items. The **SW1** switch works in conjunction with the **SW2** toggle switch. You select the function with **SW1**, and then use **SW2** to select modes or configuration settings within that function. Refer to the section “Heads-up Display Menus” on page 4-9 for details.

2. SW2 - Mode Select

SW2 is a 3-position momentary toggle switch with an automatic spring-return to the center position. Use **SW2** to enable, disable, and select specific ADC-8732B functional modes or configurations within the function menu (selected first using **SW1**).

3. JP2 - Input Select

Use **JP2** to select the input video standard. Select from the following:

- **PAL-N** — Selecting this option forces PAL-N decoding.
- **PAL-M** — Selecting this option forces PAL-M decoding.
- **PAL-B** — Selecting this option forces PAL-B decoding.
- **NTSC** — Selecting this option forces NTSC decoding.
- **AUTO** — Selecting this option enables the card to automatically detect the video input standard. This is the default setting.
- **REMOTE** — The input video standard is set remotely in Dashboard.

4. SW3 - Bootload Button

SW3 is used for factory service in the unlikely event of a complete card failure. The Bootload process is further described in the section “Bootload Button” on page 6-2.

5. JP3 - BNC 7

Use **JP3** to configure BNC 7 (TRK Pulse Out). This is useful in the DFR-8321 series frames when using the R2S-8732 Split Rear Module to take advantage of the extra SD-SDI Out. Select from the following:

- **Default** — Select this position to use BNC 7 as Track Pulse Out and BNC 8 as SD-SDI Out 6. Refer to **Figure 3.2** for jumper positions.
- **Extra SDI Out** — Select this position to use BNC 7 as SDI Out 6 and when BNC 8 is not connected. This position is advised when using the R2S-8732 Split Rear Module. Refer to **Figure 3.3** for jumper positions.

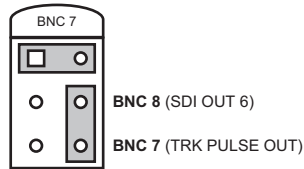

Figure 3.2 JP3 — Default Setting

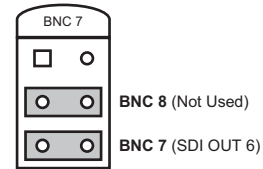

Figure 3.3 JP3 — Extra SD-SDI Out Setting

6. JP1 - EXT TERM

Use **JP1** to terminate the signal on the Reference BNC. Select from the following:

- **ON** — Select this option to terminate the signal.
- **OFF** — Select this option to leave the signal unterminated.

Tracking Pulse Output

The ADC-8732B and ADC-8732B-S offer a tracking delay output that pulses high in a two frame cycle on BNC 7. The pulse is a positive 5V signal. Its width is a measurement of the video delay through the card. The pulse tracks delay up to two video lines on the ADC-8732B and up to two fields on the ADC-8732B-S.

Control and Monitoring Features

This section provides information on the card-edge monitoring features of the ADC-8732B. These features can be used in conjunction with the Heads-Up Display (HUD). All the card-edge control functions are locked by default. To unlock the card, refer to the section “**Edit Permission**” on page 4-3. Refer to **Figure 3.4** for the location of the LEDs and controls for fan, alarm, and communications.

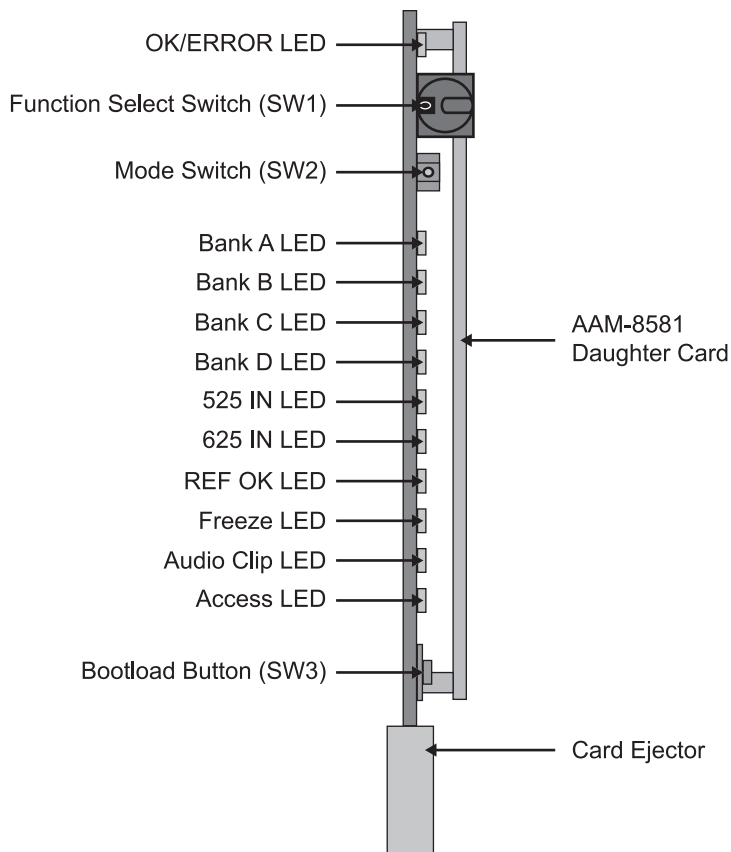

Figure 3.4 ADC-8732B Card-edge Controls

Status and Selection LEDs on the ADC-8732B

The front-edge of the ADC-8732B has LED indicators that display the status of the input signals, and indicate menu function and configuration selections. Refer to **Figure 3.4** for LED locations. Basic LED displays and descriptions are provided in **Table 3.1**.

Table 3.1 LEDs on the ADC-8732B

LED	Color	Display and Description
OK/ERROR	Green	When lit, this LED indicates that the card is functioning normal and that no anomalies have been detected. The following conditions must be satisfied: <ul style="list-style-type: none"> • a valid input signal is present • if forcing an input standard, the incoming signal matches • a valid reference signal is present when a reference is required, and that the reference standard matches the input standard. Selecting Line Sync or Frame Sync modes require that a reference signal be present.
	Red	When lit red, this LED indicates one of the following errors: <ul style="list-style-type: none"> • a valid input signal is not present • the input signal does not match the forced input standard • a valid reference signal is not present • the reference signal does not match the input signal
Bank #	Green	When lit, this LED confirms that the corresponding Bank is selected.
525 IN	Green	When lit, this LED indicates that the input signal is 525-lines (NTSC or PAL-M).
625 IN	Green	When lit, this LED indicates that the input signal is 625-lines (PAL-B or PAL-N).
REF OK	Green	When lit green, this LED indicates a reference signal is present at the Frame REF or reference BNC input, and that the reference is locked. The reference signal matches the input standard.
	Flashing	When flashing, this LED indicates that the reference standard does not match the input standard.
	Off	When not lit, this LED indicates that a reference is not present.
FREEZE	Yellow	When lit, this LED indicates that the output is frozen. (Frame Sync versions only)
AUDIO CLIP	Red	When lit, this LED indicates that one or more of the audio input levels is too high and is causing distortion at the input to the A-D converter. This LED is implemented only for the ADC-8732B-C and ADC-8732B-SC.
ACCESS	Yellow	When lit, this LED indicates that Switch Access is unlocked. The ADC-8732B card-edge controls are accessible.

Notes on Timing Modes

This section provides additional information on selecting Timing Modes for your ADC-8732B.

Line Delay Mode

This mode uses the input signal to generate the output timing. There is a constant delay between the input and the output. The reference is not used. This is useful in applications where a constant delay through the card is required. The minimum delay through the card is given in the section “**Technical Specifications**” on page 5-2. Output timing can be adjusted from this minimum delay up to an additional two lines in half-pixel increments. Refer to the section “**2 – Horizontal Delay**” on page 4-15” and the section “**4 – Vertical Interval End**” on page 4-13.

Line Sync Mode

This mode uses the reference to generate the output timing on a line-by-line basis, but uses the input signal timing to decide when a frame begins. Whenever a signal is received, the output-timing generator waits for the next falling edge of H Sync on the reference signal before outputting the received signal. The advantage of this mode is that as long as all input sources are timed to be on the same line, the output timing stays constant, regardless of which input is selected. This is very useful in that all sources to the ADC-8732B (for example, from a routing switcher) only need to be lined up to the same line. Up to two extra lines of delay can be added to the output in half-pixel increments in this mode.



Note — *If two input sources are not on the same line, then switching from one source to the other causes a jump in the output timing by an exact number of lines. For example, if the two sources are 2.5 lines apart, the output jumps by either 2 or 3 lines depending on the position of the sources with respect to the reference.*

Threshold Point

A finite amount of time is needed to process an input signal before it can be output. This is called the minimum delay. In Line Sync operation the start of the input line is delayed beyond the minimum delay until the start of the next reference line, then it is output. If the input signal’s timing slips enough, the start of its line will not have enough time to get processed and be output in time to be aligned with the start of the reference line. This point is called the threshold point. When the input signal slips to the threshold point the output will be delayed until the next reference line.

The threshold point is measured as the amount of time the input signal’s line start must lead the reference’s line start. This is 2 lines plus 38 μ s.

In addition, there is built in hysteresis so that if an input source is near the threshold point, the output timing will be constant and will not jump back and forth by a line if the input signal varies slightly. However, if the input signal is exactly on the threshold point, the output timing may vary from one power up to the next. In other words, the card may power up with different timing than the previous time it was powered-up. To avoid this condition, it is recommended to keep the input signal away from the threshold point. Two microseconds can be considered a safe distance.



Note — *In Line Sync Mode, the falling edge of the incoming video Sync should be kept away from the threshold point.*

Frame Delay Mode

The Frame Delay mode is identical to the Line Delay mode, except that the output timing can be delayed by up to a full frame of video. By using almost a full frame of delay, it is possible to set apparent negative timing, making it look like the output occurs before the input.

Frame Sync Mode

The Frame Sync mode makes it possible to use asynchronous sources. The output timing is generated entirely based on the reference. Whether a synchronous or an asynchronous source is used, output timing is constant. The delay through the card will be:

- one full frame of buffered video;
- an additional delay of anything from the minimum latency of the ADC-8732B-S (an amount in the order of less than a microsecond) up to an additional full frame of delay (two frames total).

Up to one extra frame of delay can be added to the output in half-pixel increments in this mode.

Menus

In This Chapter

This chapter provides a summary of the menus available for the ADC-8732B.

The following topics are discussed:

- SNMP Monitoring and Control
- DashBoard Menus for the ADC-8732B
- Heads-up Display Menus



Note — *For each supported line standard (525 and 625), the ADC-8732B stores the default and user-adjusted video settings independently in non-volatile memory. The selection of settings is determined by the input timing source.*

SNMP Monitoring and Control

The Network Controller Card in the DFR-8300 series frame provides optional support for remote monitoring of your frame and the using Simple Network Management Protocol (SNMP), which is compatible with many third-party monitoring and control tools.

Refer to your ADC-8732B Management Information Base (MIB) file for a breakdown of SNMP controls on this card. Refer to the *DFR-8300 Series User Manual* and the *MFC-8300 Series User Manual* for additional information on SNMP Monitoring and Control.

DashBoard Menus for the ADC-8732B

This section briefly summarizes the menus, items, and parameters available from the DashBoard Control System™ for the ADC-8732B. Note that parameters marked with an asterisk (*) are the factory default values and the values stored in the non-volatile memory are marked with an ^m.

The DashBoard Control System™ enables you to monitor and control openGear frames and cards from a computer. DashBoard communicates with other cards in the DFR-8300 series frame through the Network Controller Card.



Note — The ADC-8732B defaults with **Edit Permissions** set to **Locked**.

Status Menus

Table 4.1 summarizes the **Status** tab parameters available in DashBoard for the ADC-8732B. The **Status** tabs provide read-only information such as software revision issue, fan door status, and power consumption.

Table 4.1 Status Tab Items

Tab Title	Item	Parameters	Description
Product (Read-only)	Product	ADC-8732B	
	Supplier	Ross Video Ltd.	
	Board Rev	##	Indicates the Board revision level
	Serial Number	#####	Indicates the card serial number
	Software Rev	##.##	Indicates the software version
	Firmware Rev	#.###	Indicates the firmware version
Hardware (Read-only)	HW Status	Green - OK	Normal operation; no hardware errors
		Yellow - Check I/O Module	Card is connected to a rear model not supported by the AAM-8581 ^a
		Red - FPGA load invalid	The card failed to load the FPGA firmware
		Red - Incomp I/O Module	Card is connected to an incompatible rear module
	Voltage (mV)	#	Supply Voltage
	Current (mA)	#	Current consumption of card
	Rear Module	#	Type of rear module in the slot
	CPU Headroom	#	Processing power available
	RAM Available (bytes)	###/###	On-board processing memory available
	EE Bank	#	Storage count

Table 4.1 Status Tab Items

Tab Title	Item	Parameters	Description
Signal (Read-only)	Signal Status	Green	Indicates that the card is functioning normally and no anomalies are detected
		Yellow	The reference does not match the input standard
		Red	An error has occurred
	Input Status	Signal Present	Indicates the presence of an input signal
		No Signal	
	Input Standard	If you have the card configured for a fixed standard, this field displays that input standard.	
		If the card is configured for Auto Detect, this field tracks the input signal. On loss of input, the input standard shows the last input standard used.	
	Reference	Reference OK	Indicates the presence of a reference signal
No Reference			

- a. This message will display when the following rear modules are installed when using the AAM-8581: 8310AR-030, 8310AR-031, 8320AR-030, 8320AR-031, 8320AR-040, and 8320AR-041.

Notes on the Signal Status

When the **Signal Status** indicator in DashBoard is green, the following conditions are present:

- A valid input signal is present
- The incoming signal matches the forced input standard
- A valid reference signal is present when a reference is required and that reference standard matches the input standard. Selecting Line Sync or Frame Sync modes require that a reference signal be present.

When the **Signal Status** indicator in DashBoard is red, the following errors have occurred:

- A valid input signal is not present
- The input signal does not match the forced input standard
- A valid reference signal is not present

Setup Menu

Table 4.2 summarizes the **Setup Menu** options available in DashBoard for the ADC-8732B.

Table 4.2 Setup Menu Items

Menu Title	Item	Parameters	Description
Setup	Input Control	AUTO	When JP2 is set to REMOTE , you can specify the input video standard.
		NTSC	
		PAL-B	
		PAL-M	
		PAL-N	
	NTSC Setup ^m	Off	Disables the setup
		On	Enables the setup

Table 4.2 Setup Menu Items

Menu Title	Item	Parameters	Description
Setup	Input Mode ^m	Standard	Select if using a standard video input
		VTR	Select if using input signals that do not have a stable time base
	Decode Mode ^m (NTSC options)	3D Adaptive	Selects 3D Adaptive Decode Mode
		3 Line	Selects 3-line Decode Mode
	Decode Mode ^m (PAL options)	5 Line	Selects 5-line Decode Mode when in PAL
	Edit Permission	Unlocked	All menu options are unlocked and can be edited.
		Locked	All menu items, except this one, are locked and read-only.
	Factory Defaults	Reset	Resets all parameters to factory defaults.
	Licensable Features		Indicates if the software key for any licensable features is installed.

Timing Menus

Table 4.3 summarizes the **Timing Menu** options available in DashBoard for the ADC-8732B.

Table 4.3 Timing Menu Items

Menu Title	Item	Parameters	Description
Timing	Reference	Frame Reference 1	The reference source is the analog reference connected to the frame REF 1 port
		Frame Reference 2	The reference source is the analog reference connected to the frame REF 2 port
		BNC 9	The reference source is the analog reference connected to BNC 9
	Timing Mode ^m	Line Delay	Output timing is based on input timing
		Line Sync	Output timing is based on the reference
		Frame Delay ^a	Output timing is based on input timing
		Frame Sync ^a	Output timing is based on the reference
	Horizontal Delay ^m (half pixels)	0-1715 ^b	Adjusts the horizontal delay
		0-1727 ^c	
	Vertical Delay ^m (lines)	0-524 ^b	Adjusts the vertical delay
		0-624 ^c	
	Minimum Delay	Reset	Resets the Delay

- a. This option is only available for the ADC-8732B-S.
- b. When in 525-line mode (NTSC/PAL-M).
- c. When in 625-line mode (PAL-B/PAL-N).

Output Menu

Table 4.4 summarizes the **Output Menu** options available in DashBoard for the ADC-8732B.

Table 4.4 Output Menu Items

Tab Title	Item	Parameters	Description
Output	Input Video Loss Mode ^m	Black	When the input signal is lost or invalid, SD-SDI black is the output
		No Output	When the input signal is lost or invalid, there is no output present
		Freeze	When the input signal is lost or invalid, the last valid image is frozen, as determined by the Freeze Mode option, and used as the output
	Forced Black	Off	Disables this feature
		On	Forces the output to black
	Test Pattern	Off	Disables this feature
		SDI Check Field	
		Full Field Color Bars	
	Forced Freeze	Off	Disables this feature.
		On	Enables a forced freeze of the output. The frozen output video displayed will be determined by the Freeze Mode setting.
	Freeze Mode	Field 1	When a freeze occurs, the last Field 1 is the output.
		Field 2	When a freeze occurs, the last Field 2 is the output.
		Frame	When a freeze occurs, the last full frame is the output.

Framing Menus

Table 4.5 summarizes the **Framing Menu** options available in DashBoard for the ADC-8732B.

Table 4.5 Framing Menu Items

Menu Title	Item	Parameters	Description
Framing	Vertical Interval Blanking ^m	Pass	Pass the vertical interval
		Blank	Blank the vertical interval
	Vertical Interval End ^m	19-21 ^a	Selects the line on which the vertical interval ends
		22 ^b	
	Lock V Bit On Line ^{mb}	10	Sets the V-Bit to line 10
		20	Sets the V-Bit to line 20

a. When in 525-line mode (NTSC/PAL-M).

b. When in 625-line mode (PAL-B/PAL-N), the Vertical Interval End is fixed at 22.

Proc Amp Menus

Table 4.6 summarizes the **Proc Amp Menu** options available in DashBoard for the ADC-8732B.

Table 4.6 Proc Amp Menu Items

Menu Title	Item	Parameters	Description	
Proc Amp	Video Gain (%) ^m	50 to 150	Adjusts the output video gain level.	
	Chroma Gain (%) ^m	50 to 150	Adjusts the output chroma gain.	
	CB Gain (%) ^m	50 to 150	Adjusts the output C _B gain.	
	Hue (DEG) ^m	-43° to 44.8°	Adjusts the hue phase (in degrees).	
	Black Level Offset (IRE) ^m	-7.2 to 51.7	Adjusts the output black level of the card.	
	Super Black ^m	Pass		Enables the input to pass without clipping.
		Clip		Clips any value below black.
	Automatic Gain Control ^m	Off		Disables the Automatic Gain Control Mode (AGC).
		Chroma		Chroma values in the output are adjusted based on the input signal.
		Luma		Luminance values in the output are adjusted based on the input signal.
		Both		Chroma and luminance values in the output are adjusted based on the input signal.
Proc Amp	Reset		Resets all Proc Amp controls to the factory default values.	

Audio Menus

Table 4.7 summarizes the **Audio Menu** options available in DashBoard for the ADC-8732B.

Table 4.7 Audio Menu Items

Menu Title	Item	Parameters	Description
Analog Audio Inputs	Audio Input Gain (dB) ^m	-10.0 to +10.0	Adjusts the Audio Gain for each input
	Audio Input Status ^m	OK	Indicates that audio is present and above the selected Silence Threshold value.
		Clip	Indicates that the audio input level is too high and is causing distortion.
		No Input	Indicates that the input audio level is below the selected Silence Threshold value.

Table 4.7 Audio Menu Items

Menu Title	Item	Parameters	Description
Analog Audio Inputs	Notify Audio Input Alarm	Checkbox enabled	An alarm is triggered when the selected audio input is clipping or if it is silent for longer than the selected Silence Alarm Threshold value.
		Checkbox disabled	Disables this feature.
	Silence Threshold ^m	-6dBFS to -84dBFS	Selects the audio threshold for silence measurement and defines the audio silence threshold (-6dBFS increments)
	Silence Alarm Timeouts ^m	0 to 60	Selects the duration of silence before an alarm is displayed in the Signal tab.
Embedded Audio	Audio Mux Enable	Checkbox enabled	Embeds audio channels into the horizontal interval of the digital video.
		Checkbox disabled	Disables this feature.
	Embed to ^m	Group 1	Selects which group to embed the audio into.
		Group 2	
		Group 3	
		Group 4	
	Audio Delay (ms) ^m	0 to 5000	Selects the amount of additional audio delay to add to the input audio before it is embedded.
	Channel Source	Analog Input #	Assigns Analog Input # to the selected embedded channel.
Audio Configuration	Reset	Resets the audio settings to the factory default values.	

Alarms Menus

Table 4.8 summarizes the **Alarms Menu** options available in DashBoard for the ADC-8732B.

Table 4.8 Alarms Menu Items

Menu Title	Item	Parameters	Description
Alarms	Loss of Input	Ignore	Signal Status parameter in the Signal tab ignores loss of reference.
		Notify	Signal Status parameter in the Signal tab reports loss of reference when they occur.
	Loss of Reference	Ignore	Signal Status parameter in the Signal tab ignores loss of input conditions.
		Notify	Signal Status parameter in the Signal tab reports loss of input conditions when they occur.

Heads-up Display Menus

This section summarizes the menu system of the Heads-Up Display (HUD) and how to navigate the menus and options using the **SW1** and **SW2** switches on the ADC-8732B card-edge. The HUD feature is displayed on a separate composite monitoring output. When activated, the card status and parameters can be viewed and adjusted using the card-mounted menu switch and an easy to use menu system. A list of the available menus and parameters is also provided in this section.

Overview

The menus are split into Banks: A, B, C and D. Each bank has 16 positions, 0 though F, with position 0 (zero) reserved for the Bank designation. Positions 1 to F may contain menu items.

A particular menu is referred to as: **Bank-Menu**, for example **A-9**. The ADC-8732B must be unlocked to be able to adjust the parameters. By default, whenever the card is powered up, it is locked.

Parameters in the menus can be adjusted without turning on the HUD, but using the display gives visual feedback to ensure the parameter is adjusted correctly. The HUD is superimposed over all video outputs.



Note — *When the ADC-8732B is powered up or unlocked, it defaults to Bank A and the HUD is disabled.*

Navigation

Use the following procedure to navigate the Bank Menus of the ADC-8732B:

1. Rotate **SW1** to position **0**.
2. Toggle **SW2** up or down to select the Bank.
3. Rotate **SW1** to the required menu.
4. Toggle **SW2** to select the required parameter.

This completes the procedure for navigating the Bank Menus of the ADC-8732B.

The following tables list all the menus and the possible parameters. To activate some of these parameters, it may be necessary to toggle **SW2** in either direction, or it may require that **SW2** be held in either direction for a few seconds.

The following rules apply to the tables that are used throughout this section:

- The label “**+**” instructs you to toggle the **Mode Switch (SW2)** up momentarily.
- The label “**-**” instructs you to toggle the **Mode Switch (SW2)** down momentarily.
- The label “**+ (h)**” instructs you to hold the **Mode Switch (SW2)** up for one second.

The label “**- (h)**” instructs you to hold the **Mode Switch (SW2)** down for one second

Ballistics

In those menus where there is a wide adjustment range, a mechanism to help speed up the selection process is provided. If **SW2** is pressed and held in either direction, the values in the menu will change at an increasing faster rate. The rate of change will reach its peak after approximately two seconds. This is called **ballistics**.

Bank A Menus

Table 4.9 summarizes the functions available on Bank A.

Table 4.9 Bank A Menu and Parameters Table

Menu Select	Menu	Parameters	HUD Values
0	Bank Select	A – B – C – D	BANK A B C D
1	Heads-Up Display	+ (h) On – Off	HEADS UP ON OFF
2	--		
3	--		
4	Decode Mode (NTSC) ^m	+ 3 Line – 3D Adaptive	DECODE 3 LINE 3D ADAPT
	Decode Mode (PAL) ^m	5 Line	DECODE 5 LINE
5	Test Pattern	+ Full Field Color Bars SDI Check Field – Off	TEST PAT FF BARS PATH OFF
6	--		
7	--		
8	Video Gain ^m	+ Increase – Decrease	VID GAIN (###.#)%
9	Black Level Offset ^m	+ Increase – Decrease	BLK OFF (##.#) IRE
A	Chroma Gain ^m	+ Increase – Decrease	CHROMA (###.#)%
B	Hue ^m	+ Increase – Decrease	HUE (##.##) DEG
C	C _B Gain ^m	+ Increase – Decrease	CB GAIN (###.#)%
D	AGC	+ Both Luma Chroma – Off	AGC BOTH LUMA CHROMA OFF
E	Factory Defaults	+ (h) Reset All – (h) Reset Proc Amp	DEFAULT ALL RST PROC RST
F	Switch Access	+ (h) Locked – (h) Unlocked	ACCESS LOCKED UNLOCKED

Bank A Menu Parameters

The following section provides a brief overview of the parameters available in Bank A.

1 – Heads-Up Display

The Heads-Up Display (HUD) is used to provide visual feedback to the user while altering parameters with the card-edge controls. It is not necessary to have the HUD on while adjusting parameters.



Note — *The display is superimposed over all ADC-8732B video outputs. Do not use this feature with on-air signals.*

4 – Decode Mode

The Decode Mode function allows you to select 3-line or 3D Adaptive decoding for NTSC input signals. In PAL-B, PAL-M, and PAL-N, the decoder uses a 5-line aperture. The menu parameters will differ depending on the input signal format.

5 – Test Pattern

Use this menu to select a test pattern type, or to disable the test pattern option.



Note — *When using the SD-SDI Check Field test pattern, the HUD must be set to OFF for the test pattern to provide accurate results.*

8 – Video Gain

Use this menu to adjust the gain of the output signal. The range is 50% to 150%. This menu uses ballistics.

9 – Black Level Offset

This menu configures the black level offset that is not affected by the NTSC Setup function. The range is -7.2 to 51.7 IRE. This menu uses ballistics.

For example, with Black Level Offset at 1 IRE, a setup level of 7.5 IRE on the video input, and NTSC Setup off, the black level will be 8.5 IRE.

A — Chroma Gain

This menu allows you to adjust the Chroma portion of the output signal. The range is 50% to 150%. This menu uses ballistics.

B – Hue

Use this menu to adjust the hue of the output signal. The range is -43.0° to 44.8°. This menu uses ballistics.

C – C_B Gain

Use this menu to adjust the C_B portion of the output signal. The range is 50% to 150%. This menu uses ballistics.

D – AGC (Automatic Gain Control)

Use this menu to enable or disable the Automatic Gain Control (AGC) for Chrominance, Luminance, or both. The Proc Amp menu controls will still affect the output video with AGC enabled.

E – Factory Defaults

This function allows you to return all controls to their default values except the **HUD** and **Edit Permission** menu settings.

F – Switch Access

The ADC-8732B can be monitored using DashBoard at any time while it is powered. The card must be unlocked to adjust parameters. On power-up, the **Edit Permission** always reverts to its default value if locked. The **ACCESS LED** lights whenever the card is unlocked.

The **Switch Access** function allows you to lock or unlock user access to all adjustment parameters from the card-edge controls. The “lock” function should be performed after installation to secure all settings, and to prevent anyone from accidentally changing the settings.

Note the following rules:

- When access is locked, no adjustments can be made and the HUD is automatically turned off. The **ACCESS LED** is off.
- When access is unlocked, adjustments can be made. The **ACCESS LED** is lit. The HUD must be manually turned on again if needed.

Bank B Menus

Table 4.10 summarizes the functions available on Bank B.

Table 4.10 Bank B Menu and Parameters Table

Menu Select	Menu	Parameters	HUD Values
0	Bank Select	+ A B – C D	BANK A B C D
1	Setup ^{m a}	+ On – Off	SETUP ON OFF
2	--		
3	Vertical Interval Blanking ^m	+ Blank – Pass Through	VI BLANK BLANK PASS
4	Vertical Interval End ^m	+ Increase – Decrease	VI END (##)
5	SuperBlack ^m	+ Pass Through – Clip	SUPER BLK PASS CLIP
6	V Bit Lock ^{m a}	+ Line 20 – Line 10	V BIT LOC 20 10
7	--		

Table 4.10 Bank B Menu and Parameters Table

Menu Select	Menu	Parameters	HUD Values
8	--		
9	--		
A	--		
B	--		
C	--		
D	--		
E	--		
F	--		

a. When in 525-line mode (NTSC/PAL-M).

Bank B Menu Parameters

The following section provides a brief overview of the parameters available in Bank B.

1 – Setup

Use this menu to determine how the card controls the incoming signal with respect to NTSC setup. Select from the following:

- **ON** — Select this option if the incoming signal has setup on it. The ADC-8732B will remove it before it converts the composite signal to SD-SDI.
- **OFF** — Select this option if the incoming signal does not have setup on it.

3 – Vertical Interval Blanking

Use this menu to blank the vertical interval or allow the signals in the vertical interval to pass through the ADC-8732B.

4 – Vertical Interval End

The ADC-8732B has a programmable Vertical Interval that allows you to set where the VI ends and the first line of active video begins. Everything up to, but not including, the first line of active video is considered part of the Vertical Interval and will be affected by this function.

- In NTSC or PAL-M, signals in the vertical interval are passed without setup even if setup is enabled. The Vertical Interval End can be set to line 19, 20, or 21.
- In PAL-B and PAL-N, the Vertical Interval End is not adjustable and is set to 22.

5 – SuperBlack

Use this menu to clip SuperBlack values from the input video signal as follows:

- Allow the input's active video signal to pass through unaltered
- Clip any value below black

6 – V Bit Lock

Some types of equipment require that the transition from vertical interval to active video to be locked to either line 10 or line 20. Use this menu to select the V Bit location.



Note — V Bit location can only be moved in the NTSC/PAL-M input standards.

Bank C Menus

Table 4.11 summarizes the functions available on Bank C.

Table 4.11 Bank C Menu and Parameters Table

Menu Select	Menu	Parameters	HUD Values
0	Bank Select	+ A B C – D	BANK A B C D
1	Timing Mode ^m	+ Frame Sync ^a Frame Delay ^a Line Sync – Line Delay	TIME MODE FS FD LS LD
2	Horizontal Delay ^m	+ Increase – Decrease	H DELAY (####)
3	Horizontal Reset	+ Zero – No action	H RESET ZERO
4	Vertical Delay ^m	+ Increase – Decrease	V DELAY (#)
5	Vertical Reset	+ Zero – No action	V RESET ZERO
6	Minimum Delay	+ Zero – No action	MIN DEL ZERO
7	Input Mode ^m	+ VTR Input – Standard Input	IN MODE VTR STAND
8	Freeze Mode ^m	+ Frame Field 2 – Field 1	FRZ MODE FRAME FLD 2 FLD 1
9	Forced Freeze	+ Freeze ^b – Pass Through	FREEZE FORCE PASS
A	Input Loss Mode ^m	+ Freeze ^b No Output – Black	IN LOSS FREEZE NO OUTPUT BLACK
B	--		

Table 4.11 Bank C Menu and Parameters Table

Menu Select	Menu	Parameters	HUD Values
C	Forced Black	+ (h) On – (h) Off	FRCD BLK ON OFF
D	Forced Monochrome	+ (h) On – (h) Off	FRCD MONO ON OFF
E	--		
F	Reference ^m	+ BNC 9 Frame 1 – Frame 2	BNC9 REFERENCE FRM2 FRM1

- a. Only available on the ADC-8732B-S.
- b. When Freeze mode is enabled, the freeze is determined by the setting in Menu C-8.

Bank C Menu Parameters

The following section provides a brief overview of the parameters available in Bank C.

1 – Timing Modes

The ADC-8732B features the Line Delay and Line Sync Timing Modes. The ADC-8732B-S features the Line Delay, Line Sync, Frame Delay, and Frame Sync Timing Modes. Refer to the section “**Notes on Timing Modes**” on page 3-6 for details.

2 – Horizontal Delay

Delay can be added to the output video in half-pixel increments up to a maximum of 1715 in NTSC/PAL-M or 1727 in PAL-B/PAL-N. This menu uses ballistics.

- If you cross over the maximum Horizontal Delay, the value returns to 0 and the Vertical Delay value increments by 1.
- Crossing the minimum delay returns the Horizontal Delay value to 1715 (NTSC or PAL-M), or 1725 (PAL-B or PAL-N) and decreases the Vertical Delay value by 1.
- If at maximum Horizontal Delay and maximum Vertical Delay, incrementing the Horizontal Delay value will cause the Vertical Delay value to wrap from maximum value to the minimum value.
- If at minimum Horizontal Delay and minimum Vertical Delay, decreasing the Horizontal Delay value will cause the Vertical Delay value to wrap from minimum value to the maximum value.

3 – Horizontal Reset

This menu resets the Horizontal Delay value to 0.

4 – Vertical Delay

Extra delay can be added to the output video in line increments. Vertical Delay can add up to a maximum of 524 lines in NTSC/PAL-M or 624 lines in PAL-B/PAL-N. This menu uses ballistics.

Note the following points when adjusting the Vertical Delay:

- If you cross over the maximum Vertical Delay, the value returns to 0.

- Crossing the minimum delay returns the Vertical Delay value to 524 (NTSC or PAL-M), or 624 (PAL-B or PAL-N).

5 – Vertical Reset

Use this menu to reset the Vertical Delay value to 0.

6 – Minimum Delay

Use this menu to reset the Horizontal Delay and Vertical Delay values to 0. Note that this resets the Horizontal Delay and Vertical Delay values across all Timing Modes.

7 – Input Mode

Use this menu to select what type of video is the input. Select from the following:

- **Standard** — Select this option when using input signals with a stable time base.
- **VTR** — Select this option when using input signals that do not have a stable time base, such as VTRs. A reference should be used to reclock the output signal to the house reference. This requires that one of the **Sync Timing Modes** be enabled. Refer to the section “**1 – Timing Modes**” on page 4-15 for details.

8 – Freeze Mode

Use this menu to set what will be the output when a freeze occurs (as set by the Forced Freeze menu). This menu is only applicable for the ADC-8732B-C and ADC-8732B-SC. The output is frozen if any of the following conditions occur:

- The user freezes the output manual. Refer to the section “**9 – Forced Freeze**” above.
- There is a loss of input signal. Refer to the section “**A – Input Loss Mode**” below.

9 – Forced Freeze

The output can be manually frozen (ADC-8732B-S only) using the **Forced Freeze** menu. When enabled, it will freeze Field 1 only, Field 2 only, or the entire frame as determined by the **Freeze Mode** setting. If **Forced Freeze** is set to **ON**, the output is frozen only if the **Timing Mode** is set to **Frame Sync**.

A – Input Loss Mode

Use this menu to select what type of video appears at the system’s outputs when the input video signal is lost or invalid. Select from the following:

- **Black** — The output is set to SD-SDI black. The **Timing Mode** must be set to **Frame Sync** and the reference must be valid.
- **No Output** — No signal is present on the output.
- **Freeze** — The last valid image is automatically frozen (ADC-8732B-S only). The freeze is determined by the **Freeze Mode** setting. The **Timing Mode** must be set to **Frame Sync** and the reference must be valid.

C – Forced Black

This menu forces the output to SD-SDI Black. The output can be forced to SDI Black only when Line/Delay modes and the input signal is valid; or when in Line/Frame Sync modes and the input or reference is valid.

D – Forced Monochrome

This menu turns off the color portion of the output SD-SDI signal.

F – Reference

The Sync Timing Modes of the ADC-8732B require a reference. The recommended signal is a stable composite analog black signal. This menu selects where the card will look for that reference. The choices are BNC 9 (or BNC 10 when using the **R2S-8732** Split Rear Module), Frame Reference 1, and Frame Reference 2.

Bank D Menus

Table 4.12 summarizes the functions available on Bank D.

Table 4.12 Bank D Menu and Parameters Table

Menu Select	Menu	Parameters	HUD Values
0	Bank Select	A – B – C D	BANK A B C D
1	Audio MUX Enable ^m	+ Increase – Decrease	MUX ENABL ON OFF
2	Embed Group Select ^m	+ 1 2 3 – 4	EMBEDDED 1 2 3 4
3	Audio Delay ^{m a}	+ Increase – Decrease	AUD DELAY (#####)MS
4	Channel Source ^m	+ Increase – Decrease	MUTE CHANNEL 1 1 2 3 4
5	Channel Source ^m	+ Increase – Decrease	MUTE CHANNEL 2 1 2 3 4
6	Channel Source ^m	+ Increase – Decrease	MUTE CHANNEL 3 1 2 3 4

Table 4.12 Bank D Menu and Parameters Table

Menu Select	Menu	Parameters	HUD Values
7	Channel Source ^m	+ Increase - Decrease	MUTE 1 CHANNEL 4 2 3 4
8	Audio Input Gain ^m	+ Increase - Decrease	IN 1 GAIN (#.#)DB
9	Audio Input Gain ^m	+ Increase - Decrease	IN 2 GAIN (#.#)DB
A	Audio Input Gain ^m	+ Increase - Decrease	IN 3 GAIN (#.#)DB
B	Audio Input Gain ^m	+ Increase - Decrease	IN 4 GAIN (#.#)DB
C	Silence Threshold ^m	+ Increase - Decrease	THRESH HL -(##)DBFS
D	Audio Configuration Reset	Hold SW2 up for 3 seconds	AUD RST 0
E	--		
F	--		

- a. The minimum Audio Delay is based on the Timing Mode, Horizontal Delay, Vertical Delay, and Video Standard settings.

Bank D Menu Parameters

The following section provides a brief overview of the parameters available in Bank D.

1 – Audio MUX Enable

This menu allows you to enable the audio embedding feature on the ADC-8732B-C or ADC-8732B-SC. Select from the following:

- **ON** — The audio channels are embedded into the horizontal interval of the digital video based on the Embed To, Audio Delay, and Channel Source settings.
- **OFF** — The audio embedding feature is disabled.

3 – Audio Delay

This menu controls the amount of additional delay to be added to the input audio before it is embedded. The audio delay is entered in milliseconds and has a range of 0-5000ms (5 seconds). Note that the minimum audio delay is based on the Timing Mode, Horizontal Delay, Vertical Delay, and Video settings. This menu is used in conjunction with the Minimum Delay. This menu is only applicable for the ADC-8732B-C and ADC-8732B-SC.

- If the **Timing Mode** is set to **Frame Sync**, 1 frame of delay is added to the minimum audio delay. When using NTSC, this is equal to 33mS. When using PAL, this is equal to 40mS.

- The **Horizontal Delay** and **Vertical Delay** settings are also applied to the minimum audio delay.
- If the card is not set to **Frame Sync Mode** and the Horizontal and Vertical delay settings are set to 0, the minimum inherent delay for the audio is 3mS.

4, 5, 6, 7 – Channel Source

Use these menus to map the analog input channels to the embedded channels within the embedded group. Any input channel can be routed to any, or all, of the embedded channels within the selected group. This menu is only applicable for the ADC-8732B-C and ADC-8732B-SC.

8, 9, A, B – Audio Input Gain

Use these menus to adjust the audio gain for each input of the AAM-8581 over a range of ± 10 dBu in increments of 0.05dBu. The audio is adjusted on the AAM-8581 in the analog domain before the A-D conversion for maximum signal resolution. This menu is only applicable for the ADC-8732B-C and ADC-8732B-SC.

C – Silence Threshold

This menu selects the audio threshold for silence from a range of -84dBFS to -6dBFS in increments of 6dBFS. The value selected defines silence for the input audio level and influences when the “**No Input**” error message is displayed in the **Audio Input Status** field of DashBoard. This menu is only applicable for the ADC-8732B-C and ADC-8732B-SC.

D – Audio Configuration Reset

This feature enables you to reset the audio settings to the factory default values. This menu is only applicable for the ADC-8732B-C and ADC-8732B-SC.

Specifications

In This Chapter

This chapter provides technical information on the ADC-8732B.

The following topics are discussed:

- Technical Specifications

Technical Specifications

This section provides the technical specifications for the ADC-8732B.

Table 5.1 ADC-8732B Technical Specifications

Category	Parameter	Specification
Composite Video Input	Signal Standards Accepted	NTSC, PAL-B, PAL-M, PAL-N
	Number of Inputs	1
	Composite Video	1V p-p nominal
	Input Impedance	75ohm terminating
	Return Loss	>50dB to 6.75MHz
	Common Mode Rejection	>58dB @ 50/60Hz
Component SDI Output	Signal Standards	SMPTE 259M-C, 270Mbps 525/625 lines, 10 bits
	Number of Outputs	Full Rear Module: 7 Split Rear Module: 3
	Output Return Loss	>20dB to 270MHz
	Signal Level	800mV ±10%
	DC Offset	<75mV
	Rise and Fall Time	>800pS (20 to 80%, ±15%)
	Overshoot	<10% typical
Audio Input (R1C-8732 and R2-8732 Rear Modules only)	Number of Inputs	4
	Connector	3-pin plug to BNC
	Input Impedance	>10Kohm
	Maximum Input Level	+34dBu (input gain set to -10dBu)
	Input Level Range	±10dBu
	Frequency Response	± 0.05dB 20Hz to 22kHz @ Fs = 48kHz
Audio Performance (R1C-8732 and R2-8732 Rear Modules only)	Signal to Noise Ratio	100dB 101dB 'A' weighted 107dB CCITT weighting
	Total Harmonic Distortion	<100dB
	Inter-Modular Distortion	<0.003% (-90dB) @ -20dBFS SMPTE/DIN two-tone test
	Phase Linearity	1.2° @ 20kHz
	Amplitude Linearity	0.6dB @ -100dBFS
	Crosstalk	>98dB
	Minimum Audio Delay	3ms
	Maximum Audio Delay	5sec
	Operating Range	5°C to 40°C ambient

Table 5.1 ADC-8732B Technical Specifications

Category	Parameter	Specification
Analog Reference	Signal Standards Accepted	NTSC, PAL-B, PAL-M, PAL-N
	Number of INputs	1
	Input Impedance	75ohm
	Return Loss	>46dB to 6.75MHz
Minimum Delay in Line/Frame Delay Mode	Minimum Delay	NTSC: 2 Lines + 38μs PAL: 3 Lines +38μs
Tracking Delay Pulse	ADC-8732B	up to 2 video lines
	ADC-8732B-S, ADC-8732B-SC	up to 2 video frames
Power Consumption	Total without AAM-8581	4.0W
	Total with AAM-8581	7.8W

Service Information

In This Chapter

This chapter contains the following sections:

- Troubleshooting Checklist
- Warranty and Repair Policy

Troubleshooting Checklist

Routine maintenance to this openGear product is not required. In the event of problems with your ADC-8732B, the following basic troubleshooting checklist may help identify the source of the problem. If the frame still does not appear to be working properly after checking all possible causes, please contact your openGear products distributor, or the Technical Support department at the numbers listed under the “**Contact Us**” section.

1. **Visual Review** — Performing a quick visual check may reveal many problems, such as connectors not properly seated or loose cables. Check the card, the frame, and any associated peripheral equipment for signs of trouble.
2. **Power Check** — Check the power indicator LED on the distribution frame front panel for the presence of power. If the power LED is not illuminated, verify that the power cable is connected to a power source and that power is available at the power main. Confirm that the power supplies are fully seated in their slots. If the power LED is still not illuminated, replace the power supply with one that is verified to work.
3. **Input Signal Status** — Verify that source equipment is operating correctly and that a valid signal is being supplied.
4. **Output Signal Path** — Verify that destination equipment is operating correctly and receiving a valid signal.
5. **Unit Exchange** — Exchanging a suspect unit with a unit that is known to be working correctly is an efficient method for localizing problems to individual units.

Bootload Button

In the unlikely event of a complete card failure, you may be instructed by a Ross Technical Support specialist to perform a complete software reload on the ADC-8732B.

Use the following procedure to reload the software on a ADC-8732B:

1. Eject the card from the frame.
2. Press and hold the **Alarm Mute/Bootload** button, while re-inserting the card into the frame.
3. Release the button.
 - The **STATUS OK LED** will flash green while the card is waiting for a new software load.
 - If a new software load is not sent to the card within 60 seconds, the card will attempt to restart with its last operational software load.
 - Software loads can be sent to the ADC-8732B via the connection on the rear of the frame.

This completes the procedure for reload the software on a ADC-8732B.

Warranty and Repair Policy

The ADC-8732B is warranted to be free of any defect with respect to performance, quality, reliability, and workmanship for a period of FIVE (5) years from the date of shipment from our factory. In the event that your ADC-8732B proves to be defective in any way during this warranty period, Ross Video Limited reserves the right to repair or replace this piece of equipment with a unit of equal or superior performance characteristics.

Should you find that this ADC-8732B has failed after your warranty period has expired, we will repair your defective product should suitable replacement components be available. You, the owner, will bear any labor and/or part costs incurred in the repair or refurbishment of said equipment beyond the FIVE (5) year warranty period.

In no event shall Ross Video Limited be liable for direct, indirect, special, incidental, or consequential damages (including loss of profits) incurred by the use of this product. Implied warranties are expressly limited to the duration of this warranty.

This ADC-8732B User Manual provides all pertinent information for the safe installation and operation of your openGear Product. Ross Video policy dictates that all repairs to the ADC-8732B are to be conducted only by an authorized Ross Video Limited factory representative. Therefore, any unauthorized attempt to repair this product, by anyone other than an authorized Ross Video Limited factory representative, will automatically void the warranty. Please contact Ross Video Technical Support for more information.

In Case of Problems

Should any problem arise with your ADC-8732B, please contact the Ross Video Technical Support Department. (Contact information is supplied at the end of this publication.)

A Return Material Authorization number (RMA) will be issued to you, as well as specific shipping instructions, should you wish our factory to repair your ADC-8732B. If required, a temporary replacement frame will be made available at a nominal charge. Any shipping costs incurred will be the responsibility of you, the customer. All products shipped to you from Ross Video Limited will be shipped collect.

The Ross Video Technical Support Department will continue to provide advice on any product manufactured by Ross Video Limited, beyond the warranty period without charge, for the life of the equipment.

Contact Us

Contact our friendly and professional support representatives for the following:

- Name and address of your local dealer
- Product information and pricing
- Technical support
- Upcoming trade show information

PHONE	General Business Office and Technical Support	613 • 652 • 4886
	After Hours Emergency	613 • 349 • 0006
	Fax	613 • 652 • 4425
E-MAIL	General Information	solutions@rossvideo.com
	Technical Support	techsupport@rossvideo.com
POSTAL SERVICE	Ross Video Limited	8 John Street, Iroquois, Ontario, Canada K0E 1K0
	Ross Video Incorporated	P.O. Box 880, Ogdensburg, New York, USA 13669-0880

Visit Us

Please visit us at our website for:

- Company information
- Related products and full product lines
- On-line catalog
- News
- Testimonials

www.rossvideo.com