

# DMX-6259-A Series

**AES/EBU Audio De-Multiplexer with Fiber Optic Input  
User Manual**

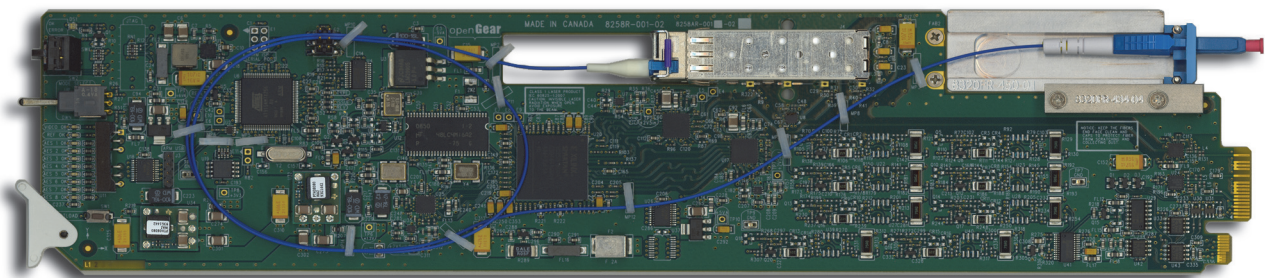

---

# DMX-6259-A Series User Manual

- Ross Part Number: 6259ADR-004-04
- Release Date: February 19, 2013.

The information in this manual is subject to change without notice or obligation.

---

## Copyright

© 2013 Ross Video Limited. All rights reserved.

This work is proprietary and confidential to Ross Video Limited, its subsidiaries and its other affiliated corporations and may not be copied, distributed, sold or otherwise used or relied upon without the express written permission of Ross Video Limited. Reproduction or reverse engineering of copyrighted software is prohibited.

---

## Patents

This product is protected by the following US Patents: 4,205,346; 5,115,314; 5,280,346; 5,561,404; 7,304,886; 7,508,455; 7,602,446; 7,834,886; 7,914,332. This product is protected by the following Canadian Patents: 2039277; 1237518; 1127289. Other patents pending.

---

## Notice

The material in this manual is furnished for informational use only. It is subject to change without notice and should not be construed as commitment by Ross Video Limited. Ross Video Limited assumes no responsibility or liability for errors or inaccuracies that may appear in this manual.

---

## Trademarks

-  is a registered trademark of Ross Video Limited.
- Ross, ROSS, ROSS®, and MLE are registered trademarks of Ross Video Limited.
- openGear® is a registered trademark of Ross Video Limited.
- DashBoard Control System™ is a trademark of Ross Video Limited.
- Java and all Java-based marks are trademarks or registered trademarks of Sun Microsystems, Inc. in the United States and other countries. Ross Video Limited is independent of Sun Microsystems, Inc.
- Apple® Mac OS®, Leopard®, Snow Leopard™, and Lion™ are trademarks of Apple Inc., registered in the U.S. and other countries.
- Microsoft®, Internet Explorer®, and Windows® are either registered trademarks or trademarks of Microsoft Corporation in the U.S.A. and/or other countries.
- Linux® is the registered trademark of Linus Torvalds in the U.S. and other countries.
- Firefox® is a registered trademark of the Mozilla Foundation.
- All other product names and any registered and unregistered trademarks mentioned in this manual are used for identification purposes only and remain the exclusive property of their respective owners.

---

# Important Regulatory and Safety Notices to Service Personnel

Before using this product and any associated equipment, refer to the “**Important Safety Instructions**” listed below to avoid personnel injury and to prevent product damage.

Product may require specific equipment, and/or installation procedures to be carried out to satisfy certain regulatory compliance requirements. Notices have been included in this publication to call attention to these specific requirements.

## Symbol Meanings



---

*This symbol on the equipment refers you to important operating and maintenance (servicing) instructions within the Product Manual Documentation. Failure to heed this information may present a major risk of damage to persons or equipment.*

---



---

**Warning** — The symbol with the word “**Warning**” within the equipment manual indicates a potentially hazardous situation, which, if not avoided, could result in death or serious injury.

---



---

**Caution** — The symbol with the word “**Caution**” within the equipment manual indicates a potentially hazardous situation, which, if not avoided, may result in minor or moderate injury. It may also be used to alert against unsafe practices.

---



---

**Notice** — The symbol with the word “**Notice**” within the equipment manual indicates a potentially hazardous situation, which, if not avoided, may result in major or minor equipment damage or a situation which could place the equipment in a non-compliant operating state.

---



---

**ESD Susceptibility** — This symbol is used to alert the user that an electrical or electronic device or assembly is susceptible to damage from an ESD event.

---

## Important Safety Instructions



---

**Caution** — This product is intended to be a component product of the DFR-8300 series frame. Refer to the DFR-8300 Series Frame User Manual for important safety instructions regarding the proper installation and safe operation of the frame as well as its component products.

---



---

**Warning** — Certain parts of this equipment namely the power supply area still present a safety hazard, with the power switch in the OFF position. To avoid electrical shock, disconnect all A/C power cords from the chassis’ rear appliance connectors before servicing this area.

---



---

**Warning** — Service barriers within this product are intended to protect the operator and service personnel from hazardous voltages. For continued safety, replace all barriers after any servicing.

---

*This product contains safety critical parts, which if incorrectly replaced may present a risk of fire or electrical shock. Components contained with the product’s power supplies and power supply area, are not intended to be customer serviced and should be returned to the factory for repair. To reduce the risk of fire, replacements fuses must be the same time and rating. Only use attachments/accessories specified by the manufacturer.*

---

## EMC Notices

### United States of America FCC Part 15

This equipment has been tested and found to comply with the limits for a class A Digital device, pursuant to part 15 of the FCC Rules. These limits are designed to provide reasonable protection against harmful interference when the equipment is operated in a commercial environment. This equipment generates, uses, and can radiate radio frequency energy and, if not installed and used in accordance with the instruction manual, may cause harmful interference to radio communications. Operation of this equipment in a residential area is likely to cause harmful interference in which case the user will be required to correct the interference at their own expense.



**Notice** — *Changes or modifications to this equipment not expressly approved by Ross Video Limited could void the user's authority to operate this equipment.*

---

### CANADA

This Class "A" digital apparatus complies with Canadian ICES-003.

Cet appareil numérique de la classe "A" est conforme à la norme NMB-003 du Canada.

### EUROPE

This equipment is in compliance with the essential requirements and other relevant provisions of CE Directive 93/68/EEC.

### INTERNATIONAL

This equipment has been tested to **CISPR 22:1997** along with amendments **A1:2000** and **A2:2002**, and found to comply with the limits for a Class A Digital device.



**Notice** — *This is a Class A product. In domestic environments, this product may cause radio interference, in which case the user may have to take adequate measures.*

---

## Maintenance/User Serviceable Parts

Routine maintenance to this openGear product is not required. This product contains no user serviceable parts. If the module does not appear to be working properly, please contact Technical Support using the numbers listed under the "Contact Us" section on the last page of this manual. All openGear products are covered by a generous 5-year warranty and will be repaired without charge for materials or labor within this period. See the "Warranty and Repair Policy" section in this manual for details.

---

# Important Laser Safety Measures and Notices

Before using this product and any associated equipment, refer to the sections below so as to avoid personnel injury and to prevent product damage. For further safety information when using fiber products, consult the following publications:

- *IEC-60825- 2, Safety of Laser Products - Part 2: Safety of Optical Fiber Communication Systems (OFCS)* (for use outside of the U.S.A.)
- *ANSI Z136.2, Safe Use of Optical Fiber Communication Systems Utilizing Laser Diode and LED Sources* (for use in the U.S.A.)

Products may require specific equipment, and /or installation procedures be carried out to satisfy certain regulatory compliance requirements.



---

**Caution** — *Before operating or servicing this product, all personnel should be familiar with laser safety and fiber handling practices.*

---

## Safety Measures for Operation

During normal operation of this product, heed the following safety measures:

- Do not stare at, or into, broken, or damaged, fibers.
- Do not stare at, or into, optical connectors.
- Only properly trained and authorized personnel shall be permitted to perform laser/fiber optic operations.
- Ensure that appropriate labels are displayed in plain view and in close proximity to the optical port on the protective housing/access panel of the terminal equipment.

## Safety Measures for Maintenance and Servicing



---

**Warning** — *Do not use optical equipment, such as a microscope or an eye loupe, to stare at the energized fiber end. Doing so may damage your eyes.*

---

During maintenance and servicing of this product, only properly trained and authorized personnel shall be allowed to use optical test or diagnostic equipment.

## Laser Information



---

**CLASS 1 LASER PRODUCT**  
*IEC 60825-1:2007*

**Caution** — *INVISIBLE LASER RADIATION WHEN OPEN. AVOID EXPOSURE TO THE BEAM.*

---

## Environmental Information

**The equipment that you purchased required the extraction and use of natural resources for its production. It may contain hazardous substances that could impact health and the environment.**

To avoid the potential release of those substances into the environment and to diminish the need for the extraction of natural resources, Ross Video encourages you to use the appropriate take-back systems. These systems will reuse or recycle most of the materials from your end-of-life equipment in an environmentally friendly and health conscious manner.

The crossed out wheelie bin symbol invites you to use these systems.



If you need more information on the collection, re-use, and recycling systems, please contact your local or regional waste administration.

You can also contact Ross Video for more information on the environmental performance of our products.

---

## Company Address



### **Ross Video Limited**

8 John Street  
Iroquois, Ontario, K0E 1K0  
Canada

### **Ross Video Incorporated**

P.O. Box 880  
Ogdensburg, New York  
USA 13669-0880

General Business Office: (+1) 613 • 652 • 4886

Fax: (+1) 613 • 652 • 4425

Technical Support: (+1) 613 • 652 • 4886

After Hours Emergency: (+1) 613 • 349 • 0006

E-mail (Technical Support): [techsupport@rossvideo.com](mailto:techsupport@rossvideo.com)

E-mail (General Information): [solutions@rossvideo.com](mailto:solutions@rossvideo.com)

Website: <http://www.rossvideo.com>



# Contents

- Introduction 1**
  - Overview..... 1-2
    - Features..... 1-2
  - Functional Block Diagram..... 1-3
  - User Interfaces ..... 1-4
    - DashBoard Control System™ ..... 1-4
    - Card-edge Controls..... 1-4
    - SNMP Monitoring and Control..... 1-4
  - Documentation Terms and Conventions..... 1-5
  
- Installation 2**
  - Before You Begin ..... 2-2
    - Static Discharge..... 2-2
    - Unpacking..... 2-2
    - Working with Fiber Optic Connectors ..... 2-2
  - Installing the DMX-6259-A Series ..... 2-3
    - Supported Rear Modules ..... 2-3
    - Installing a Rear Module ..... 2-3
    - Installing the Card ..... 2-4
  - Cabling..... 2-5
    - Cabling Overview..... 2-5
  - Software Upgrades..... 2-6
  
- User Controls 3**
  - Card Overview ..... 3-2
  - Control and Monitoring Features..... 3-3
    - Status and Selection LEDs ..... 3-3
  - Reference Compatibility ..... 3-5
  - Operation Notes ..... 3-6
    - Audio Proc Amp Controls ..... 3-6
    - Minimum Delay Overview..... 3-6
    - De-embedding Non-PCM Signals ..... 3-6
  
- DashBoard Menus 4**
  - Status Tabs ..... 4-2
    - Signal Tab..... 4-2
    - Hardware Tab ..... 4-3
    - Product Tab ..... 4-4
  - Setup Tab ..... 4-5
  - Input Status Tab ..... 4-7
  - AES Outputs 1-8 Tabs ..... 4-8
  - Embedded Outputs Tab ..... 4-9
  - Alarm Enables Tab ..... 4-10

<b>Card-edge Menus</b>	<b>5</b>
Navigating the Card-edge Menu System .....	5-2
Card-edge Menus .....	5-3
Menu Descriptions .....	5-5
<b>Specifications</b>	<b>6</b>
DMX-6259-A Technical Specifications .....	6-2
DMX-6259-A-H Technical Specifications .....	6-4
Channel Status Data Table .....	6-6
Passing the Status Bytes .....	6-6
<b>Service Information</b>	<b>7</b>
Troubleshooting Checklist .....	7-2
Bootload Button .....	7-2
Warranty and Repair Policy .....	7-3

# Introduction

---

## In This Chapter

This chapter contains the following sections:

- Overview
- Functional Block Diagram
- User Interfaces
- Documentation Terms and Conventions

## A Word of Thanks

Congratulations on choosing an openGear DMX-6259-A Series AES/EBU Audio De-Multiplexer with Fiber Optic Input. Your DMX-6259-A series card is part of a full line of Digital Products within the openGear Terminal Equipment family of products, backed by Ross Video's experience in engineering and design expertise since 1974.

You will be pleased at how easily your new DMX-6259-A series card fits into your overall working environment. Equally pleasing is the product quality, reliability and functionality. Thank you for joining the group of worldwide satisfied Ross Video customers!

Should you have a question pertaining to the installation or operation of your DMX-6259-A series card, please contact us at the numbers listed on the back cover of this manual. Our technical support staff is always available for consultation, training, or service.

---

# Overview

This section briefly outlines the features of the DMX-6259-A series cards.

## DMX-6259-A

The DMX-6259-A AES/EBU Audio De-Multiplexer with Fiber Optic Input is a broadcast quality de-embedder with one multi-rate SDI input which supports up to eight AES (16 channels) audio outputs. The AES outputs are 75ohm unbalanced. A single mode fiber interface with a LC/UPC connector provides an SDI input. A selectable coax input is also provided.

The DMX-6259-A can produce up to eight AES outputs, extracting them from any of the 16 possible audio channels of the SD or HD-SDI input. The AES outputs are 48kHz, synchronous with the video output. The AES outputs have the following adjustments available: delay, gain, and invert.

Card status and control parameters are displayed in the DashBoard Control System™.

## DMX-6259-A-H

The DMX-6259-A-H is a version of the DMX-6259-A that includes high sensitivity receive SFPs for increased link budget. The DMX-6259-A-H is compatible with standard 1310nm transmitters, and the CWDM transmitters from 1260nm to 1620nm (attenuation may be required to reduce optical power below -9dBm).

## Features

The DMX-6259-A series cards include the following features:

- Supports HD-SD SDI SMPTE 292M, 1.5Gbps and SMPTE 259M, 270Mbps
- Supports AES-3id-2001, and EBU Tech 3250
- Supports de-embedding of non-PCM data such as Dolby® Digital and Dolby® E
- Audio de-embedding for all popular formats 480i, 576i, 720p, and 1080i
- Eight AES-3id 75ohm unbalanced outputs on DIN 1.0/2.3 connectors
- DMX-6259-A offers an optical input sensitivity of -18dBm
- DMX-6259-A-H offers an optical input sensitivity of -28dBm
- One SDI processed output
- Automatic input video format detection
- SNMP support available
- User defined loss of signal output
- Audio controls such as gain, invert, and delay
- Internally generated test patterns and test tones
- Reports status and configuration remotely via the DashBoard Control System™
- Fits DFR-8321 series frames
- 5-year transferable warranty

# Functional Block Diagram

This section provides a functional block diagram that outlines the workflow of the DMX-6259-A series.

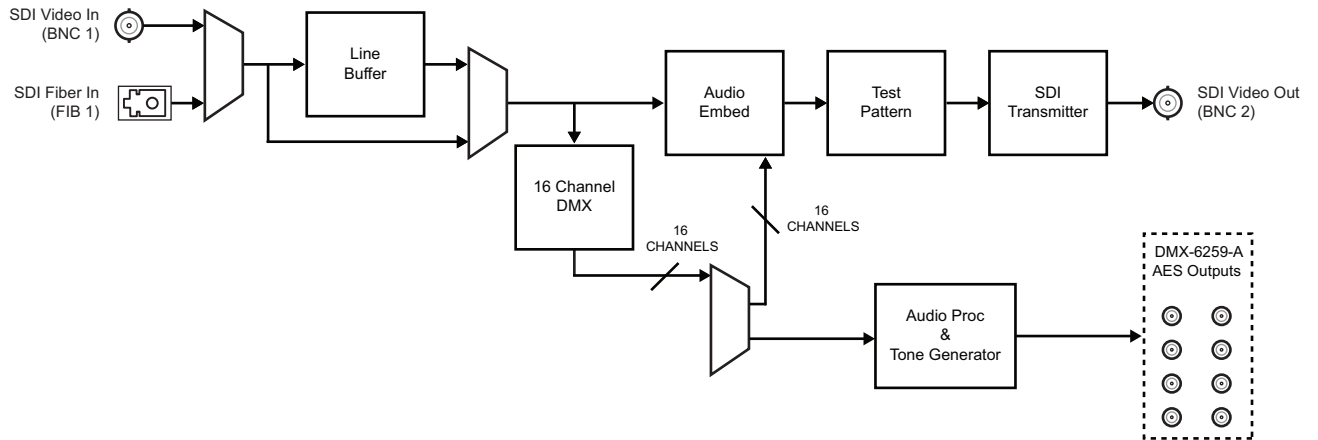

**Figure 1.1** Simplified Block Diagram

---

# User Interfaces

The DMX-6259-A series cards include the following user interfaces.

## DashBoard Control System™

The DashBoard Control System™ enables you to monitor and control openGear frames and cards from a computer. DashBoard communicates with other cards in the DFR-8321 series frame through the MFC-8300 Series Network Controller Card.

### *For More Information on...*

- installing and using DashBoard, refer to the *DashBoard User Manual*.
- menus available in DashBoard for the DMX-6259-A series, refer to the chapter “**DashBoard Menus**” on page 4-1.

## Card-edge Controls

The front-edge of the DMX-6259-A series cards feature LED indicators for the power, video input status, and communication activity. The card-edge also includes the SW2 and SW3 switches that can be used in conjunction to navigate the card-edge menu system.

### *For More Information on...*

- the card-edge controls and LEDs, refer to the section “**Card Overview**” on page 3-2.
- the card-edge menus, refer to the chapter “**Card-edge Menus**” on page 5-1.

## SNMP Monitoring and Control

The Network Controller Card in the DFR-8321 series frame provides optional support for remote monitoring of your frame and cards using the Simple Network Management Protocol (SNMP), which is compatible with many third-party monitoring and control tools.

### *For More Information on...*

- enabling SNMP Monitoring and Control for your frame, refer to the *MFC-8300 Series User Manual*.
- SNMP controls for the card, refer to the Management Information Base (MIB) for your card.

---

# Documentation Terms and Conventions

The following terms and conventions are used throughout this manual.

## Terms

The following terms are used:

- “**525-line mode**” refers to broadcast situations using **NTSC** composite (analog) signal reference inputs.
- “**625-line mode**” refers to broadcast situations using **PAL-B** composite (analog) signal reference inputs.
- “**Board**” and “**Card**” refer to openGear terminal devices within openGear frames, including all components and switches.
- “**DFR-8321 series frame**” includes all versions of the DFR-8321 series and any available options unless otherwise noted.
- “**DMX-6259-A**” refers to the non-high sensitivity version of the card.
- “**DMX-6259-A-H**” refers to the high sensitivity version of the card.
- “**DMX-6259-A series**” refers to all versions of the card unless otherwise noted.
- “**Frame**” refers to DFR-8321 series frames that house the DMX-6259-A series card.
- “**Operator**” and “**User**” refer to the person who uses DMX-6259-A series card.
- “**PAL**” refers to PAL-B unless otherwise stated.
- “**System**” and “**Video system**” refer to the mix of interconnected production and terminal equipment in your environment.

## Conventions

The following conventions are used:

- The “**Operating Tips**” and “**Note**” boxes are used to provide additional user information.



# Installation

---

## In This Chapter

This chapter provides instructions for installing the rear module(s) for the DMX-6259-A series card, installing the card into the DFR-8321 series frame, cabling details, and updating the card software.

The following topics are discussed:

- Before You Begin
- Installing the DMX-6259-A Series
- Cabling
- Software Upgrades

---

# Before You Begin

Before proceeding with the instructions in this chapter, ensure that your DFR-8321 series frame is properly installed according to the instructions in the *DFR-8300 Series User Manual*.

## Static Discharge

Throughout this chapter, please heed the following cautionary note:



---

**ESD Susceptibility** — *Static discharge can cause serious damage to sensitive semiconductor devices. Avoid handling circuit boards in high static environments such as carpeted areas and when synthetic fiber clothing is worn. Always exercise proper grounding precautions when working on circuit boards and related equipment.*

---

## Unpacking

Unpack each card you received from the shipping container and ensure that all items are included. If any items are missing or damaged, contact your sales representative or Ross Video directly.

## Working with Fiber Optic Connectors

Keep the following in mind when working with fiber optic connectors:

- Every time you are required to insert a connector into a device or mating sleeve, you must clean the connector. All exposed surfaces of the ceramic ferrule must be clean. Follow your facility practices of cleaning fiber optic connectors.
- Connectors must always be inserted into a device or have a dust cap on. Refer to **Figure 2.1** for dust cap locations.
- A poor optical connection is often similar to a poor electrical connection. Try removing the connector, cleaning, and re-inserting the connector. A bad connection can result in experiencing instability of signal, high loss, or a noisy signal.

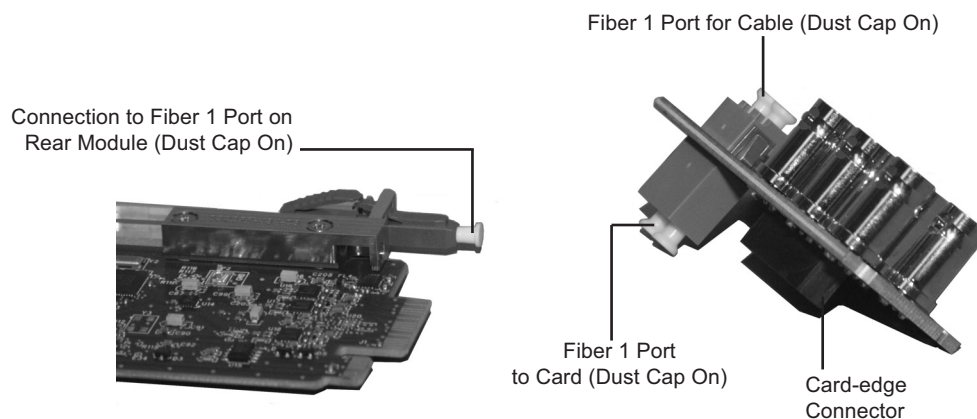

**Figure 2.1** Card Connectors with Dust Caps Installed

# Installing the DMX-6259-A Series

This section outlines how to install a rear module and then your card in an DFR-8321 series frame. You cannot install the DMX-6259-A series card in a DFR-8310 series or a DFR-8320 series frame.



**Caution** — *Never attempt to look down the barrel of a connected fiber or device transmitting an optical signal. The transmitted light is not in the visible spectrum and may cause permanent eye damage. Turn off all laser sources before disconnecting devices.*

## Supported Rear Modules

This section outlines the rear modules supported by each model of the DMX-6259-A series card.

### DMX-6259-A

The **8320AR-048A** Full Rear Module is required when installing the DMX-6259-A.

### DMX-6259-A-H

The **8320AR-048A** Full Rear Module is required when installing the DMX-6259-A-H.

## Installing a Rear Module

If the rear module is already installed, proceed to the section “**Installing the Card**” on page 2-4.

### To install a rear module in your DFR-8321 series frame

1. Locate the card frame slots on the rear of the DFR-8321 series frame.
2. Remove the Blank Plate from the slot you have chosen for the card installation.
3. Remove the dust caps from the Fiber ports on the rear module that face the interior of the frame. Refer to **Figure 2.1** and **Figure 2.2** for dust cap locations.

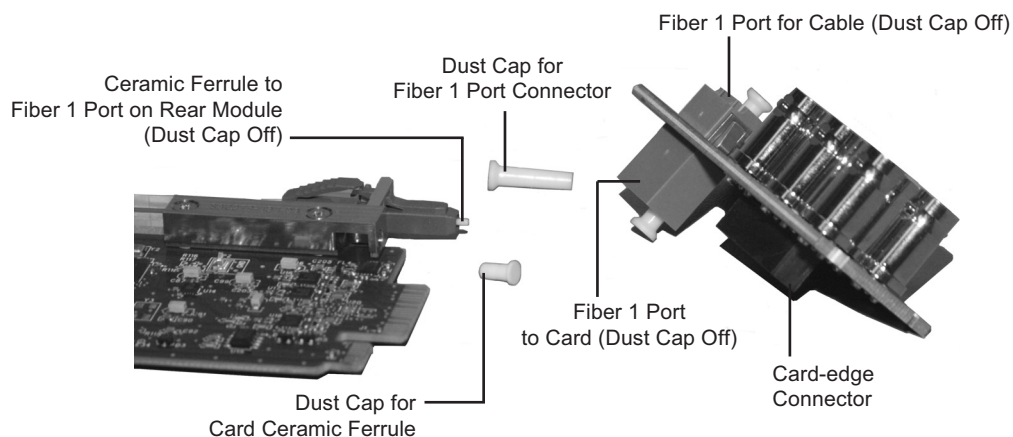

**Figure 2.2** Card Connectors with Dust Caps Removed — DMX-6259-A

4. Install the bottom of the rear module in the **Module Seating Slot** at the base of the frame’s back plane.

5. Align the top hole of the rear module with the screw on the top-edge of the frame back plane.
6. Using a Phillips screwdriver and the supplied screw, fasten the rear module to the back plane of the frame. Do not over tighten.
7. Ensure proper frame cooling and ventilation by having all rear frame slots covered with rear modules or blank plates.

## Installing the Card

The card uses a single mode, LC/UPC connector to interface with the **8320AR-048A** Full Rear Module. This section outlines how to install the card in a DFR-8321 series frame.

### To install the card in a DFR-8321 series frame

1. Locate the rear module you installed in the procedure “**Installing a Rear Module**” on page 2-3.
2. Ensure the rear module is the **8320AR-048A** Full Rear Module.
3. Remove the dust cap from the connector on the card end.
  - Refer to **Figure 2.1** and **Figure 2.3** for dust cap locations.
  - Refer to the section “**Important Laser Safety Measures and Notices**” at the beginning of this manual for safety information when handling fiber optic components.

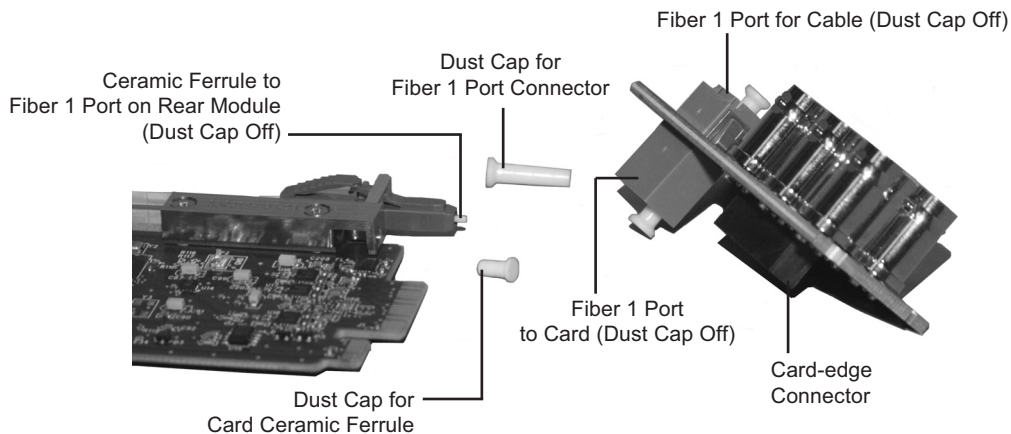

**Figure 2.3** Card Connectors with Dust Caps Removed — DMX-6259-A

4. Ensure that the exposed surface of the ceramic ferrule of the connector is clean. Refer to the section “**Working with Fiber Optic Connectors**” on page 2-2 for cleaning tips.
5. Hold the card by the edges and carefully align the card-edges with the slots in the frame.
6. Fully insert the card into the frame until the rear connection plus is properly seated in the rear module. You will feel a click when the card mates onto the rear module.
7. Affix the supplied Rear Module Label, as per the included instructions, to the BNC area of the rear module.
8. Remove the dust cap from the **Fiber 1** port (the topmost fiber optic port) on the rear module that faces the exterior of the frame.
9. Ensure the ceramic ferrule of the **Fiber 1** port connector is clean.
10. Cable your rear module as outlined in the section “**Cabling**” on page 2-5.

# Cabling

This section provides information for connecting cables to the installed rear module. Connect the input and output cables according to the following sections.

The optical connector used to mate the card to the rear module is designed for blind mate optical connectors. All fiber interfaces are single mode fibers.



**Caution** — Never attempt to look down the barrel of a connected fiber or device transmitting an optical signal. The transmitted light is not in the visible spectrum and may cause permanent eye damage. Turn off all laser sources before disconnecting devices.

## Cabling Overview

The DMX-6259-A series card is used with the **8320AR-048A** Full Rear Module. Each module occupies two slots and accommodates one card. This module provides one fiber input, one SDI input, one SDI output, and eight AES unbalanced outputs at 75ohm. (**Figure 2.4**)



**Note** — You must use the **Setup** tab in DashBoard to specify which SDI Source to use as the input (BNC or Optical Port).

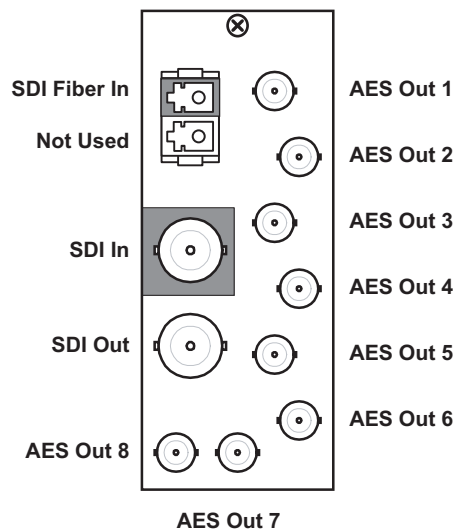

**Figure 2.4** Cable Designations for the 8320AR-048A Rear Module



**Caution** — Do not exceed the maximum input power of -9dBm on the DMX-6259-A-H. Doing so will damage the card.

---

# Software Upgrades

This section provides instructions for upgrading the software for your card using the DashBoard client. The DashBoard client enables you to upload software updates to the card.

## To upload software to the card

1. Contact Ross Technical Support for the latest software version file.
2. In DashBoard, display the **Device** tab of the card by double-clicking its status indicator in the **Basic Tree View**.
3. From the **Device** tab, click **Upload** to display the **Select File for upload** dialog box.
4. Navigate to the \*.bin upload file you wish to upload. DashBoard automatically selects the last directory that you loaded from.
5. Click **Open** to display a confirmation dialog box. This dialog box displays the selected upload file name, type, size, and the file creation date.
6. From the **Confirmation** dialog box, select one of the following:
  - **Cancel** — Select this option to cancel the upload of the file and return to the **Device View**.
  - **Continue** — Select this option to upload the file. While uploading, an **Uploading Progress** dialog box opens.



---

**Notice** — Pressing the **Cancel** button while uploading will leave the card in an invalid state. Do not click **Cancel** unless the uploading progress has stopped completely for 60 seconds or more. If upload fails, repeat the upload process from DashBoard. If the upload process fails again, refer to the section “**Bootload Button**” on page 7-2.

---

7. Monitor the upgrade progress bar displayed in DashBoard while the software is upgraded on your card.
8. To complete the upgrade process, the card automatically reboots.



---

**Note** — The communications processor of the DMX-6259-A requires approximately 30 seconds to re-start and re-establish network communications.

---

- The card automatically saves all your settings before starting the reboot process.
- The status of all the cards in the frame are grayed out until the reboot process is complete.

# User Controls

---

## In This Chapter

This chapter provides a general overview of the user controls available on the front edge of the card.

The following topics are discussed:

- Card Overview
- Control and Monitoring Features
- Reference Compatibility
- Operation Notes

# Card Overview

This section provides a general overview of the card components.

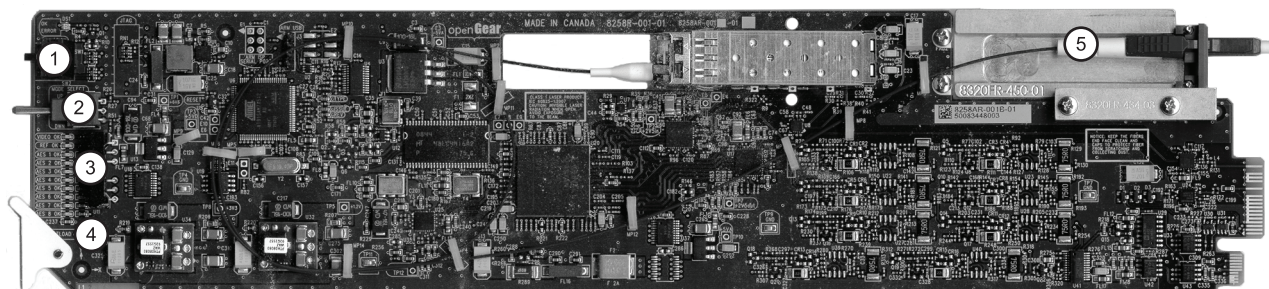

**Figure 3.1** DMX-6259-A — Card-edge Components

1) Function Select Switch	3) Four Character Display	5) Fiber Optic Connector
2) Mode Select Switch	4) Bootload Button	

## 1. Function Select Switch

Use this switch to select general operation functions and menu items. This switch works in conjunction with the Mode Select Switch.

## 2. Mode Select Switch

Use this switch to enable, disable, and select specific configurations within the operational function modes menu (selected first with the Function Select Switch).

## 3. Four Character Display

This display is located on the card-edge and reports the menu and options selected using the Function Select Switch and the Mode Select Switch.

## 4. Bootload Button

Use this button for factory service in the unlikely event of a complete card failure. Do not press this button unless instructed to do so by Ross Technical Support personnel.

## 5. Fiber Optic Connector

The card uses a blind mate, single mode, LC/UPC connector to interface with the Full Rear Module (8320AR-048A). The rear module is passive, which allows for the card to be replaced without the need to remove any connected BNC or fiber optic cables.

The fiber optic connector for the card includes a dust cap. The dust cap must stay on at all times when not installed in a frame. Ensure to keep the fibers end face clean and use the caps to protect the fiber from scratches and collecting dust.

### **For More Information on...**

- using the switches, refer to the section “**Navigating the Card-edge Menu System**” on page 5-2.
- the LEDs located on the card-edge, refer to the section “**Status and Selection LEDs**” on page 3-3.
- handling fiber optic components, refer to the section “**Important Laser Safety Measures and Notices**” at the beginning of this manual.
- using fiber connectors, refer to the section “**Working with Fiber Optic Connectors**” on page 2-2.

# Control and Monitoring Features

This section provides information on the card-edge LEDs for the card. Refer to **Figure 3.2** for the location of the LEDs and controls.

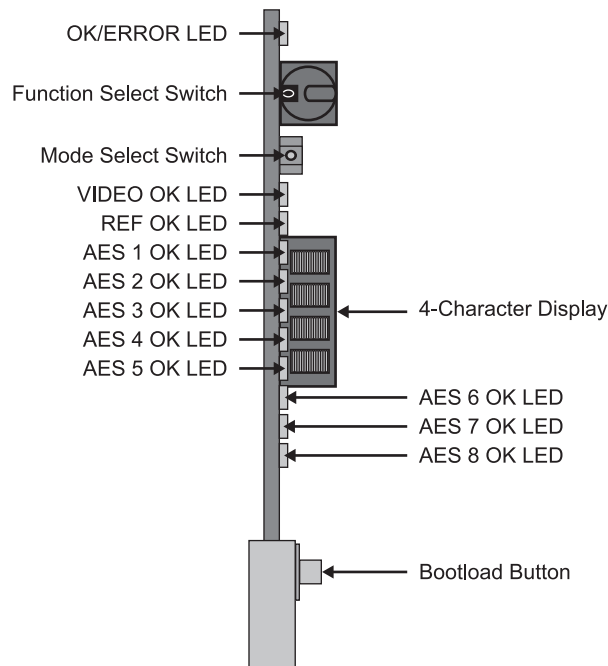

**Figure 3.2** Card-edge Controls

## Status and Selection LEDs

The front-edge of the card has LED indicators for the power, video input status, and communication activity. Basic LED displays and descriptions are provided in **Table 3.1**.

**Table 3.1** LEDs on the DMX-6259-A

LED	Color	Display and Description
OK/ERROR	Green	When lit green, this LED indicates that the card is functioning normal and that no anomalies have been detected. The following conditions must be satisfied: <ul style="list-style-type: none"> <li>• a valid input signal is present</li> <li>• a valid reference signal is present when a reference is required, and that the reference standard matches the input standard.</li> </ul>
	Flashing Green	When flashing green, this LED indicates the bootloader is waiting for a software upload.
	Flashing Green and Orange	When lit green with flashing orange, this LED indicates there is a signal error such as a missing or invalid input or reference.
	Orange	When lit orange, this LED indicates the card is powering on.
	Red	When lit red, this LED indicates the card is not operational.
	Off	When off, this LED indicates there is no power to the card.

**Table 3.1 LEDs on the DMX-6259-A**

<b>LED</b>	<b>Color</b>	<b>Display and Description</b>
<b>VIDEO OK</b>	Green	When lit, this LED indicates that the video input is valid.
	Flashing Green	When flashing, this LED indicates that video is present, but the input format is unsupported.
	Off	When unlit, this LED indicates the absence of an input signal.
<b>REF OK</b>	Green	When lit green, this LED indicates a valid reference signal.
	Flashing Green	When flashing, this LED indicates that the reference signal is present but the format is invalid.
	Off	When unlit, this LED indicates that a reference signal is not present, or is not supported.
<b>AES 1 OK</b>	Yellow	When lit, this LED indicates the presence of the embedded audio Group 1 on the video input.
<b>AES 2 OK</b>	Yellow	When lit, this LED indicates the presence of the embedded audio Group 2 on the video input.
<b>AES 3 OK</b>	Yellow	When lit, this LED indicates the presence of the embedded audio Group 3 on the video input.
<b>AES 4 OK</b>	Yellow	When lit, this LED indicates the presence of the embedded audio Group 4 on the video input.
<b>AES 5 OK</b>	Yellow	This LED is not implemented.
<b>AES 6 OK</b>	Yellow	This LED is not implemented.
<b>AES 7 OK</b>	Yellow	This LED is not implemented.
<b>AES 8 OK</b>	Yellow	This LED is not implemented.

---

## Reference Compatibility

It is important to remember that if you are using the source connected to either **Frame 1** or **Frame 2** BNCs on the openGear series frames as the reference, the input video frame rate must match the reference frame rate. Refer to **Table 3.2** for frame rate compatibility.

**Table 3.2 Compatible Video Formats**

Reference	Output					
	480i/59.94	720p/59.94	1080i/59.94	576i/50	1080i/50	720p/50
<b>480i/59.94</b>	✓	✓	✓			
<b>720p/59.94</b>	✓	✓	✓			
<b>1080i/59.94</b>	✓	✓	✓			
<b>576i/50</b>				✓	✓	✓
<b>720p/50</b>				✓	✓	✓
<b>1080i/50</b>				✓	✓	✓

---

## Operation Notes

This section provides brief notes when operating the card such as using the proc amp control, the minimum delay, and de-embedding PCM versus Non-PCM signals.

### Audio Proc Amp Controls

The card includes Processing Amplifiers (Proc Amps) for the audio outputs on the card. Note that these features are not available when using the card-edge controls.

Proc Amp adjustments are applied in the following order:

1. **Delay** — This option enables you to adjust the delay of the audio channel. If you have enabled the Delay Lock feature, changing the delay value for one channel automatically changes the value for the other channel.
2. **Gain** — This option allows you to adjust the gain by +/- 20dB in 1dB increments. If you have enabled the Gain Lock feature, changing the gain value for one channel automatically changes the value for the other channel.
3. **Invert** — This option enables you to invert the polarity of the audio signal for the selected channel.

### Minimum Delay Overview

The line buffer stores incoming video in relation to the incoming video clock timing. The video data is then read out in relation to the reference timing. This allows the input video to be switched between sources that may not be perfectly timed without timing glitches. Video source timing must remain within the buffer window to properly switch between sources. **Table 3.3** provides information on the buffer window available depending on how the Minimum Delay feature is configured in DashBoard.

**Table 3.3 Minimum Delay**

If the option is...	Format	Minimum Delay	Maximum Delay
<b>Disabled</b>	SD	1/4 line	1/2 line
	HD	1/4 line	1/2 line
<b>Enabled</b>	SD	1/8 line	1/4 line
	HD	1/16 line	1/8 line

### De-embedding Non-PCM Signals



---

**Note** — *When de-embedding non-PCM signals, channel pairs must be kept together.*

---

#### To configure the card to de-embed non-PCM signals

1. Launch DashBoard on your computer and display the **Device View** for the card you wish to configure.
2. Select the **AES Outputs** tab for the output channel you wish to configure.
3. Set the **Channel Gain** to **0**.
4. Clear the applicable **Ch Invert** check box to disable inverting on the channel.

# DashBoard Menus

---

## In This Chapter

This chapter briefly summarizes the menus, items, and parameters available from the DashBoard Control System™ for the card. Parameters marked with an asterisk (\*) are the factory default values.

The following topics are discussed:

- Status Tabs
- Setup Tab
- Input Status Tab
- AES Outputs 1-8 Tabs
- Embedded Outputs Tab
- Alarm Enables Tab

## Status Tabs

This section summarizes the read-only information displayed in the Status tabs. The fields in the **Status** tabs vary in severity from green (valid), yellow (caution), to red (alarm). DashBoard reports the most severe alarm for a single field.

### Signal Tab

**Table 4.1** summarizes the read-only information displayed in the **Signal** tab.

**Table 4.1 Signal Tab Items**

Tab Title	Item	Parameters	Description
Signal	Signal Status	OK	Indicates when the card is functioning normally or if anomalies are detected
		No Input	
		Invalid Format	
		Incompatible	
		Non-Sync Video	
		Group Not Present	
	Group Channel Silent		
	Audio Status	OK	Indicates the status of the audio source
		PCM - Silent	
		Source Async	
		Group 4 Reduced to 20bit <sup>a</sup>	
	Reference Status	OK	Indicates that a valid reference source is present
		No Ref - Video	The following conditions are occurring: <ul style="list-style-type: none"> <li>• Card reference is set to Frame 1 or Frame 2</li> <li>• A valid reference signal is not present</li> <li>• Card has gone to Video Timing Mode</li> </ul>
		No Ref - Free Run	The following conditions are occurring: <ul style="list-style-type: none"> <li>• Card reference is set to Frame 1 or Frame 2</li> <li>• A valid reference signal is not present</li> <li>• A valid video signal is not present</li> <li>• Card has gone to Free Run Mode</li> </ul>
		Invalid Format - Video	Card has detected an invalid <sup>b</sup> reference format and has switched to Video Timing Mode
	Invalid Format - Free Run	The following conditions are occurring: <ul style="list-style-type: none"> <li>• Card has detected an invalid<sup>b</sup> reference format</li> <li>• Input video is missing or invalid</li> <li>• Card has switched to Free Run Mode</li> </ul>	

**Table 4.1 Signal Tab Items**

Tab Title	Item	Parameters	Description	
<b>Signal</b>	Input Format	#	Indicates the input video format	
	Reference Format	#	Indicates the reference video format	
	Output Format	#	Indicates the output video format	
	Optical Module Status	OK		Indicates the status of the card Optical Module
		Temp High		
		Temp Low		
		Rx Power High		
		Rx Power Low		
		Rx Fault		
Not Detected				
Optical Rx Power (dBm)	#	Indicates the power at the optical input. This value is accurate to $\pm 3$ dBm.		
<b>Signal — Embedded Audio Status</b>	Group #	PCM	Indicates the status of the incoming embedded audio	
		No Input		
		PCM-Silent		
		Non-PCM		
		Async		
		Mixed		

- a. This parameter indicates that there are more than 3 groups of 24bit SD embedded audio sources.
- b. Refer to the section “**Reference Compatibility**” on page 3-5 for a complete list of supported references.

## Hardware Tab

Table 4.2 summarizes the read-only information displayed in the **Hardware** tab.

**Table 4.2 Hardware Tab Items**

Tab Title	Item	Parameters	Description
<b>Hardware</b>	HW Status	OK	Indicates the status of the hardware including the SFP module. Some messages displayed are dependent on the settings in the <b>Alarms Enable</b> tab
		FPGA load invalid	
		Incomp I/O module	
		Current out of spec	
		Internal Error	
		SFP Temp Low	
		SFP Temp High	
		SFP Power High	
		SFP Power Low	
		SFP Not Detected	
	Voltage (mV)	#	Supply Voltage
Current (mA)	#	Current consumption of card	

**Table 4.2 Hardware Tab Items**

Tab Title	Item	Parameters	Description
<b>Hardware</b>	Optical Module Temperature (C)	#	Indicates the optical module temperature
	CPU Headroom	#	Processing power available
	RAM Available	###	On-board processing memory available
	Uptime (h)		Displays the number of hours since the last reboot of the card
	Configuration Bank	#	Storage count

## Product Tab

Table 4.3 summarizes the read-only information displayed in the **Product** tab.

**Table 4.3 Product Tab Items**

Tab Title	Item	Parameters	Description
<b>Product</b>	Product	DMX-6259-A, or DMX-6259-A-H	
	Supplier	Ross Video Ltd.	
	Board Rev	##	Indicates the board version
	Rear Module	#	Type of rear module in the slot
	Board S/N	#####	Indicates the board serial number
	Software Rev	##.##	Indicates the software version
	Firmware Rev	#.###	Indicates the firmware version

## Setup Tab

Table 4.4 summarizes the Setup options available in DashBoard.

**Table 4.4 Setup Menu Items**

Menu Title	Item	Parameters	Description
Setup	SDI Source	Copper	Assigns the BNC as the SDI input source
		Optical*	Assigns Optical Port 1 as the SDI input source
	Reference	Frame 1*	Specifies the reference source
		Frame 2	
		Video	
	Minimum Delay	Selected*	Provides the shortest video delay through the card. When using SD, the delay is 7 $\mu$ s. When using HD, the delay is 1.5 $\mu$ s.
		Cleared	The total video delay through the card will be the values above plus half a video line
	Loss of Input	Black	Sets the output to Black in the event of a loss of video input
		Blue	Sets the output to Blue in the event of a loss of video input
		Custom*	Sets the output to a custom color in the event of a loss of video input. Use the Y, Cr, and Cb sliders to configure the color.
	Loss of Input	Y slider	Sets the luminance component of the Loss of Input Custom video signal.
		Cr slider	Sets the Cr component of the Loss of Input Custom video signal.
		Cb slider	Sets the Cb component of the Loss of Input Custom video signal.
	Test Pattern <sup>a</sup>	None	Disables the test pattern feature
		100% Color Bars	Specifies the type of test pattern to output
		Frequency Sweep	
		Black	
		Blue	
		Matrix Pathological	
		Luma Ramp	
		Y/C Ramp	
75% SMPTE Bars			
SD Audio	20 Bit*	Embeds 20bit audio	
	24 Bit	Embeds 24bit audio	
	Auto	Embeds 20-24bit audio depending on the source and number of bits	

**Table 4.4 Setup Menu Items**

Menu Title	Item	Parameters	Description
<b>Setup</b>	Silence Threshold (dB)	-96 to 0	Audio below the specified threshold value is considered silent
	Silence Timeout (sec)	1 to 60	Audio silent for longer than the specified value raises an alarm
	Edit Permission	Unlocked*	All menu options are unlocked and can be edited.
		Locked	All menu items, except this one, are locked and read-only.
	All Audio	Reset	Resets the parameters in the Embedded Audio Outputs tab to factory defaults
	Factory Defaults	Reset	Resets all parameters to factory defaults.

- a. This setting is not retained on power down.

## Input Status Tab

Table 4.5 summarizes the **Input Status Menu** options available in DashBoard.

**Table 4.5 Input Status Menu Items**

Menu Title	Item	Parameters	Description
Input Status	Input Format (Read-only)	#	Displays the format of the video input
	CRC Errors (Read-only)	#	Displays the count of the CRC errors on the video input. This 14bit counter is reset on loss of video, or by user request. The counter is non-latching, and will roll over from maximum count to zero. <ul style="list-style-type: none"> <li>• For SD formats, it displays both active picture and full frame errors.</li> <li>• For HD formats, it displays the total count of errors.</li> </ul>
	Error Count	Reset	Resets the CRC Errors field
	Embedded Audio - Group # Channel # (Read-only)	PCM	Displays the status of each group and channel of embedded audio
		No Input	
		PCM-Silent	
		Non-PCM	
Async			
Word Length (Read-only)	Mixed	#bit	Displays the word length of the audio in number of bits

# AES Outputs 1-8 Tabs

Table 4.6 summarizes the AES Outputs 1-4 and AES Outputs 5-8 options available in DashBoard.

**Table 4.6 AES Outputs Menu Items**

Menu Title	Item	Parameters	Description
AES #	Ch A Source	Mute	Selects the source of the AES output
		Group # Ch#	
		#Hz	
		#kHz	
	Ch B Source	Same as above	
	Ch A Delay (ms)	0* to 1000	Adjusts the delay of the audio channel
	Ch B Delay (ms)	Same as above	
	Delay Lock	Selected*	Locks the Delay slider of both channels together. If the values for the two channels are different, that change is maintained when the channels are locked.
		Cleared	The Delay slider is unlocked
	Ch A Gain (dB)	-20 to +20 <sup>a</sup>	Adjusts the gain of the audio channel
	Ch B Gain (dB)	Same as above	
	Gain Lock	Selected*	Locks the Gain slider of both channels together. If the values for the two channels are different, that change is maintained when the channels are locked.
		Cleared	The Gain slider is unlocked
	Ch A Invert	Selected	Inverts the audio signal of the channel
		Cleared*	The audio signal is not inverted
	Ch B Invert	Same as above	
Output	Reset	Resets the parameters for the selected output to the default values	
Outputs #-#	Reset	Resets the indicated output parameters to the default values	

a. The default value is 0.

## Embedded Outputs Tab

Table 4.7 summarizes the **Embedded Outputs Menu** options available in DashBoard.

**Table 4.7 Embedded Outputs Menu Items**

Menu Title	Item	Parameters	Description
<b>Group #</b>	Enable	Selected*	Determines if the group is inserted in the output or not
		Cleared	
	Ch # Source	Mute	Configures the Primary Source that is inserted in to the embedded group if present
		Group# Ch#	
		#Hz Tone	
		#kHz Tone	
	Group #	Reset	Resets the specific group sources to the default values
	All Groups	Reset	Resets all groups to the default values

# Alarm Enables Tab

Table 4.8 summarizes the Alarm Enables options available in DashBoard.

**Table 4.8 Alarms Menu Items**

Menu Title	Item	Parameters	Description	
<b>Video Input &amp; Reference Alarm</b>	No Input	Selected*	Signal Status field reports a loss of input	
		Cleared	Disables the alarm	
	Invalid Input	Selected*	Input Format field displays an alarm when the input video is a format that is not supported	
		Cleared	Disables the alarm	
	Incompatible Input	Selected*	Input Format field reports when the frame rate is not the same as the reference input	
		Cleared	Disables the alarm	
	Non-Sync Input	Selected*	Signal Status field reports if the video input is asynchronous to the reference	
		Cleared	Disables the alarm	
	No Reference	Selected*	Reference Status field reports loss of input conditions	
		Cleared	Disables the alarm	
	Invalid Reference	Selected*	Reference Format field reports when the reference is a format that is not supported	
		Cleared	Disables the alarm	
	<b>Hardware</b>	Incompat Rear Module	Selected*	Hardware Status field reports when a rear module is not compatible with the card
			Cleared	Disables the alarm
<b>Optical Module Alarms</b>	Alarm on Abnormal Temperature	Selected*	Hardware Status field reports when the temperature of the SFP module is not in range (high/low)	
		Cleared	Disables the alarm	
	Alarm on Abnormal Power	Selected*	Hardware Status field reports when the power consumption of the SFP module is not in range (high/low)	
		Cleared	Disables the alarm	
	Alarm on Not Detected	Selected*	Hardware Status field reports when the optical module is not detected	
		Cleared	Disables the alarm	
<b>Embedded Input Audio - Group #</b>	Group not present	Selected*	Signal Status field reports when a group is not present on the input	
		Cleared	Disables the alarm	
	Channel # Silent	Selected*	Signal Status field reports when the specified channel is detected as silent	
		Cleared	Disables the alarm	

**Table 4.8 Alarms Menu Items**

<b>Menu Title</b>	<b>Item</b>	<b>Parameters</b>	<b>Description</b>
<b>AES Outputs - AES #</b>	Source Missing	Selected*	Audio Status field reports when the source is not detected
		Cleared	Disables the alarm
	Source Async	Selected*	Audio Status field reports when the selected output source is asynchronous to the input video
		Cleared	Disables the alarm
<b>Embedded Outputs - Group #</b>	Source Missing	Selected*	Embedded Audio Status field reports when the selected source is not present or is silent
		Cleared	Disables the alarm
	Source Async	Selected*	Embedded Audio Status field reports when the selected source is asynchronous to the input video
		Cleared	Disables the alarm
	SD 24Bit	Selected*	Audio Status field reports when the selected configuration would embed 4 groups of 24bit audio in an SD output. Group 4 is down-sampled to 20bit audio.
		Cleared	Disables the alarm
	All Alarms	Set	Enables all alarms
	All Alarms	Clear	Disables all alarms



# Card-edge Menus

---

## In This Chapter

This chapter provides a summary of the menus available for the card.

The following topics are discussed:

- Navigating the Card-edge Menu System
- Card-edge Menus
- Menu Descriptions

---

# Navigating the Card-edge Menu System

This section summarizes how to navigate the menus and options using the **SW1** and **SW2** switches on the card-edge.

## To navigate the card-edge menus

1. Rotate **SW1** to the required menu.
2. Toggle **SW2** to select the required parameter.



**Note** — *Do not power down the card before ensuring that all edited parameters are saved. Saving edited parameters can take up to 10 seconds.*

---

## Card-edge Menus

**Table 5.1** lists all the menus, and menu items available using the card-edge controls. To activate some of these parameters, it may be necessary to toggle **SW2** in either direction, or it may require that **SW2** be held in either direction for a few seconds. Default values are indicated with an asterisk (\*). Refer to the section “**Menu Descriptions**” on page 5-5 for a brief summary of the menus available on the card-edge.

**Table 5.1 Card-edge Menus and Items**

Menu Select	Card-Edge Menu Label	Menu Name	Card-Edge Item Label	Item Name
0	DMX-6259-A slot #, or DMX-6259-A-H slot #	Home		
1	Fact Def	Factory Default	n/a	Factory Default
2	Ref Src	Reference Source	Fr 1*	Frame 1 Reference
			Fr 2	Frame 2 Reference
			Vid	Video
3	LOI	Loss of Input	Black	
			Blue	
			Custom*	
4	Test Patt	Test Pattern	None*	
			75%	SMPTE Bars
			YC Ramp	Y/C Ramp
			L Ramp	Luma Ramp
			Matr Path	Matrix Pathological
			Blue	Flat Field Blue
			Black	Flat Field Black
			Frq Swp	Frequency Sweep
5	Grp Sel	Group Select	Grp 1	Group 1
			Grp 2	Group 2
			Grp 3	Group 3
			Grp 4	Group 4
6	Grp Enbl	Group Enable	Enabled*	
			Disabled	

**Table 5.1 Card-edge Menus and Items**

<b>Menu Select</b>	<b>Card-Edge Menu Label</b>	<b>Menu Name</b>	<b>Card-Edge Item Label</b>	<b>Item Name</b>
<b>7</b>	Ch1 Src	Channel 1 Source	Mute	
			T4k	4kHz Tone
			T2k	2kHz Tone
			T1k	1kHz Tone
			T.5k	500Hz Tone
			G1C1 - G4C4	Group 1, Channel 1 to Group 4, Channel 4
<b>8</b>	Ch2 Src	Channel 2 Source	Same as above	
<b>9</b>	Ch3 Src	Channel 3 Source	Same as above	
<b>A</b>	Ch4 Src	Channel 4 Source	Same as above	
<b>B</b>	AES Sel	AES Output Select	AES1*- AES8	AES 1 to AES 8
<b>C</b>	ChA Src	Channel A Source	G1C1 - G4C4	Group 1, Channel 1 to Group 4, Channel 4
<b>D</b>	ChB Src	Channel B Source	Same as above	

---

# Menu Descriptions

This section briefly summarizes the menu parameters available in the card-edge display.

## 0 — Home

This read-only menu displays the product name and the slot the card is installed in the frame.

## 1 — Factory Defaults

This function enables you to return all controls to their factory default values.

To reset the card parameters to factory default values using the card-edge controls:

1. Rotate **SW1** to **1**. The Four Character Display displays “**Fact Def**”.
2. Toggle **SW2** down and hold for 3 seconds.
3. Release **SW2**.

## 2 — Reference Source

This menu enables you to select where the card will look for a reference. The choices are Frame Reference 1 (**Fr 1**), Frame Reference 2 (**Fr 2**), and Video (**Vid**). Refer to the section “**Reference Compatibility**” on page 3-5 for details.

## 3 — Loss of Input

Use this menu to select what type of video displays at the system’s outputs when the input video signal is lost or invalid.

## 4 — Test Pattern

This menu enables you to specify the type of test pattern to output. Note that this setting is not retained on power down.

## 5 — Group Select

This menu enables you to select the embedded group before assigning sources to the channels, enabling the group, and selecting backup sources. This menu is used in conjunction with Menus 6 to E.

## 6 — Group Enable

Use this menu to determine if the selected group is embedded in the output or not.

## 7, 8, 9, A — Channel # Source

Use Menus 7 to A to configure the source that is inserted into the embedded group if present. These menus are used in conjunction with Menu 5 (Group Select). The following are the default values based on the group selected:

- Group 1 — When Menu 5 is set to Grp1, the default value of Menu 7 is G1C1.
- Group 2 — When Menu 5 is set to Grp 2, the default value of Menu 8 is G2C2.
- Group 3 — When Menu 5 is set to Grp 3, the default value of Menu 9 is G3C3.
- Group 4 — When Menu 5 is set to Grp 4, the default value of Menu A is G4C4.

## **B — AES Select**

Use Menu B to specify an AES output to configure. This menu is used in conjunction with Menus C (Channel A Source) and D (Channel B Source). The default value is AES1.

## **C — Channel A Source**

Use Menu C to select the Channel A source for a specific AES output. This menu is used in conjunction with Menu B (AES Select). The following are the default values based on the AES selected:

- When Menu B is set to AES1, the default value of Menu C is G1C1.
- When Menu B is set to AES2, the default value of Menu C is G1C3.
- When Menu B is set to AES3, the default value of Menu C is G2C1.
- When Menu B is set to AES4, the default value of Menu C is G2C3.
- When Menu B is set to AES5, the default value of Menu C is G3C1.
- When Menu B is set to AES6, the default value of Menu C is G3C3.
- When Menu B is set to AES7, the default value of Menu C is G4C1.
- When Menu B is set to AES8, the default value of Menu C is G4C3.

## **D — Channel B Source**

Use Menu D to select the Channel B source for a specific AES output. This menu is used in conjunction with Menu B (AES Select). The following are the default values based on the AES selected:

- When Menu B is set to AES1, the default value of Menu D is G1C2.
- When Menu B is set to AES2, the default value of Menu D is G1C4.
- When Menu B is set to AES3, the default value of Menu D is G2C2.
- When Menu B is set to AES4, the default value of Menu D is G2C4.
- When Menu B is set to AES5, the default value of Menu D is G3C2.
- When Menu B is set to AES6, the default value of Menu D is G3C4.
- When Menu B is set to AES7, the default value of Menu D is G4C2.
- When Menu B is set to AES8, the default value of Menu D is G4C4.

# Specifications

---

## In This Chapter

This chapter provides technical specification details on the card. Note that specifications are subject to change without notice.

The following topics are discussed:

- DMX-6259-A Technical Specifications
- DMX-6259-A-H Technical Specifications
- Channel Status Data Table

# DMX-6259-A Technical Specifications

This section includes the technical specifications for the DMX-6259-A.

**Table 6.1 DMX-6259-A Technical Specifications**

Category	Parameter	Specification
<b>Optical Input</b>	Number of Inputs	1
	SMPTE Standards Accommodated	SMPTE 259M, SMPTE 292M
	Operating Wavelength Range	1210nm to 1620nm
	Input Power Operating Range (Color Bars)	<ul style="list-style-type: none"> <li>• -3dBm to -18dBm @ 2.97Gbps</li> <li>• -3dBm to -19dBm @ 270Mbps and 1.5Gbps</li> </ul>
	Input Power Operating Range (Pathological)	<ul style="list-style-type: none"> <li>• -3dBm to -17dBm @ 2.97Gbps</li> <li>• -3dBm to -18dBm @ 270Mbps and 1.5Gbps</li> </ul>
	Receiver Overload	At values above -3dBm
	Connector	Single mode, LC/UPC
<b>SDI Input</b>	Number of Inputs	1
	SDI Data Rates and SMPTE Standards Accommodated	SMPTE 259M, SMPTE 292M
	Impedance	75ohm terminating
	Return Loss	>15dB to 1.485GHz >10dB from 1.485GHz to 2.97GHz
	Cable Length with Equalizer	>300m of Belden 1694A cable @ 270Mbps >120m of Belden 1694A cable @ 1.485Gbps >80m of Belden 1694A cable @ 2.97Gbps
	Connector Type	BNC
<b>SDI Output</b>	Number of Outputs	1
	SDI Data Rates and SMPTE Standards Accommodated	SMPTE 259M, SMPTE 292M
	Impedance	75ohm
	Return Loss	>15dB to 1.485GHz >10dB 1.485GHz to 2.97GHz
	Signal Level	800mV, ±10%
	DC Offset	0V ±50mV
	Rise and Fall Time (20-80%)	<ul style="list-style-type: none"> <li>• 700ps typical @ 270Mbps</li> <li>• 120ps typical @ 1.485Gbps, 2.97Gbps</li> </ul>
	Overshoot	<10%
	Connector Type	BNC

**Table 6.1 DMX-6259-A Technical Specifications**

<b>Category</b>	<b>Parameter</b>	<b>Specification</b>
<b>AES Outputs</b>	Number of Outputs	8 AES-3id outputs
	Impedance	75ohm
	Resolution	24bits
	Voltage	1V p-p
	Sampling Rate	48kHz
	Connector Type	DIN 1.0/2.3
<b>Environmental</b>	Operating Range	5°C to 40°C ambient
<b>Power</b>	Total Power Consumption	<8W

# DMX-6259-A-H Technical Specifications

This section includes the technical specifications for the DMX-6259-A-H.



**Caution** — Do not exceed the maximum input power of -9dBm on the DMX-6259-A-H. Doing so will damage the card.

**Table 6.2 DMX-6259-A-H Technical Specifications**

Category	Parameter	Specification
<b>Optical Input</b>	Number of Inputs	1
	SMPTE Standards Accommodated	SMPTE 292M, SMPTE 259M
	Operating Wavelength Range	1260nm to 1620nm
	Input Power Operating Range (Color Bars)	<ul style="list-style-type: none"> <li>• -9dBm to -28dBm @ 2.97Gbps</li> <li>• -9dBm to -28dBm @ 270Mbps and 1.5Gbps</li> </ul>
	Input Power Operating Range (Pathological)	<ul style="list-style-type: none"> <li>• -9dBm to -28dBm @ 2.97Gbps</li> <li>• -9dBm to -28dBm @ 270Mbps and 1.5Gbps</li> </ul>
	Receiver Overload	At values above -9dBm
	Maximum Input Power	-9dBm
	Connector	Single Mode, LC/UPC, APD
<b>SDI Input</b>	Number of Inputs	1
	SDI Data Rates and SMPTE Standards Accommodated	SMPTE 259M, SMPTE 292M
	Impedance	75ohm terminating
	Return Loss	>15dB to 1.485GHz >10dB from 1.485GHz to 2.97GHz
	Cable Length with Equalizer	>300m of Belden 1694A cable @ 270Mbps >120m of Belden 1694A cable @ 1.485Gbps >80m of Belden 1694A cable @ 2.97Gbps
	Connector Type	BNC

**Table 6.2 DMX-6259-A-H Technical Specifications**

Category	Parameter	Specification
<b>SDI Output</b>	Number of Outputs	1
	SDI Data Rates and SMPTE Standards Accommodated	SMPTE 259M, SMPTE 292M
	Impedance	75ohm
	Return Loss	>15dB to 1.485GHz >10dB 1.485GHz to 2.97GHz
	Signal Level	800mV, ±10%
	DC Offset	0V ±50mV
	Rise and Fall Time (20-80%)	<ul style="list-style-type: none"> <li>• 700ps typical @ 270Mbps</li> <li>• 120ps typical @ 1.485Gbps, 2.97Gbps</li> </ul>
	Overshoot	<10%
	Connector Type	BNC
<b>AES Outputs</b>	Number of Outputs	8 AES-3id outputs
	Impedance	75ohm
	Resolution	24bits
	Voltage	1V p-p
	Sampling Rate	48kHz
	Connector Type	DIN 1.0/2.3
<b>Environmental</b>	Operating Range	5°C to 40°C ambient
<b>Power</b>	Total Power Consumption	<8W

## Channel Status Data Table

The following table shows the channel status bit information that is used for all output audio.

**Table 6.3 Channel Status Data**

Byte	Bit	Function	Transmitted
0	0	Professional or Consumer use of Channel Status Block	Professional (1)
	1	Normal Audio or Non-Audio Mode	Normal Audio (0)
	2-4	Emphasis	No Emphasis (100)
	5	Lock Indication	Locked (0)
	6-7	Sampling Rate	48kHz (01)
1	0-3	Channel Mode	2 channel stereo (0001)
	4-7	User Bit Mode	192-bit (0001)
2	0-2	Auxiliary Bit Usage	20-bit audio sample, Aux bits undefined (000)
	3-5	Sample Word Length	20- or 24-bits (101)
	6-7	Alignment Level	Not Indicated (00)
3	0-7	Multi-channel Modes	Undefined (0)
4	0-1	Digital Audio Reference Signal	Not a Reference (0)
	2	Reserved	0
	3-6	Sampling Frequency	Not Indicated (0000)
	7	Sampling Frequency Scaling Flag	No Scaling (0)
5	0-7	Reserved	Unused (0)
6-9		ASCII Source ID	Unused (0)
10-13		ASCII Destination ID	Unused (0)
14-17		Local Sample Address	Unused (0)
18-21		Time of Day	Unused (0)
22	0-7	C data reliability	Only the first 5 Status Bytes are marked as Reliable All other Status Bytes are marked as Unreliable
23	0-7	CRC	Calculated CRC

### Passing the Status Bytes

The DMX-6259-A series card replaces Channel Status Bytes according to **Table 6.3** or passes Status Bytes through from input to output. In order for the Channel Status Bytes on the incoming embedded stream to be re-embedded, the outgoing Data Word Length must match the specified word length in the Channel Status bits.

# Service Information

---

## In This Chapter

This chapter contains the following sections:

- Troubleshooting Checklist
- Warranty and Repair Policy

---

# Troubleshooting Checklist

Routine maintenance to this openGear product is not required. In the event of problems with your DMX-6259-A series card, the following basic troubleshooting checklist may help identify the source of the problem. If the frame still does not appear to be working properly after checking all possible causes, please contact your openGear products distributor, or the Technical Support department at the numbers listed under the “**Contact Us**” section.

1. **Visual Review** — Performing a quick visual check may reveal many problems, such as connectors not properly seated or loose cables. Check the card, the frame, and any associated peripheral equipment for signs of trouble.
2. **Power Check** — Check the power indicator LED on the distribution frame front panel for the presence of power. If the power LED is not illuminated, verify that the power cable is connected to a power source and that power is available at the power main. Confirm that the power supplies are fully seated in their slots. If the power LED is still not illuminated, replace the power supply with one that is verified to work.
3. **Input Signal Status** — Verify that source equipment is operating correctly and that a valid signal is being supplied.
4. **Output Signal Path** — Verify that destination equipment is operating correctly and receiving a valid signal.
5. **Unit Exchange** — Exchanging a suspect unit with a unit that is known to be working correctly is an efficient method for localizing problems to individual units.

## Bootload Button

In the unlikely event of a complete card failure, you may be instructed by a Ross Technical Support specialist to perform a complete software reload on the card.

### To reload the software on a card

1. Eject the card from the frame.
2. Press and hold the **Bootload** button, while re-inserting the card into the frame.
3. Release the button.
  - The **STATUS OK LED** will flash green while the card is waiting for a new software load.
  - If a new software load is not sent to the card within 60 seconds, the card will attempt to restart with its last operational software load.
  - Software loads can be sent to the card via the connection on the rear of the frame.

---

## Warranty and Repair Policy

The DMX-6259-A series card is warranted to be free of any defect with respect to performance, quality, reliability, and workmanship for a period of FIVE (5) years from the date of shipment from our factory. In the event that your DMX-6259-A series card proves to be defective in any way during this warranty period, Ross Video Limited reserves the right to repair or replace this piece of equipment with a unit of equal or superior performance characteristics.

Should you find that this DMX-6259-A series card has failed after your warranty period has expired, we will repair your defective product should suitable replacement components be available. You, the owner, will bear any labor and/or part costs incurred in the repair or refurbishment of said equipment beyond the FIVE (5) year warranty period.

In no event shall Ross Video Limited be liable for direct, indirect, special, incidental, or consequential damages (including loss of profits) incurred by the use of this product. Implied warranties are expressly limited to the duration of this warranty.

This DMX-6259-A Series User Manual provides all pertinent information for the safe installation and operation of your openGear Product. Ross Video policy dictates that all repairs to the DMX-6259-A series card are to be conducted only by an authorized Ross Video Limited factory representative. Therefore, any unauthorized attempt to repair this product, by anyone other than an authorized Ross Video Limited factory representative, will automatically void the warranty. Please contact Ross Video Technical Support for more information.

### In Case of Problems

Should any problem arise with your DMX-6259-A series card, please contact the Ross Video Technical Support Department. (Contact information is supplied at the end of this publication.)

A Return Material Authorization number (RMA) will be issued to you, as well as specific shipping instructions, should you wish our factory to repair your DMX-6259-A series card. If required, a temporary replacement frame will be made available at a nominal charge. Any shipping costs incurred will be the responsibility of you, the customer. All products shipped to you from Ross Video Limited will be shipped collect.

The Ross Video Technical Support Department will continue to provide advice on any product manufactured by Ross Video Limited, beyond the warranty period without charge, for the life of the equipment.

# Contact Us

Contact our friendly and professional support representatives for the following:

- Name and address of your local dealer
- Product information and pricing
- Technical support
- Upcoming trade show information

## Technical Support

Telephone: +1 613 • 652 • 4886  
After Hours Emergency: +1 613 • 349 • 0006  
Email: [techsupport@rossvideo.com](mailto:techsupport@rossvideo.com)

## General Information

Telephone: +1 613 • 652 • 4886  
Fax: +1 613 • 652 • 4425  
Email: [solutions@rossvideo.com](mailto:solutions@rossvideo.com)  
Website: <http://www.rossvideo.com>

## Visit Us

Visit our website for:

- Company information and news
- Related products and full product lines
- Online catalog
- Testimonials