

ADA-7551
Audio Distribution Amplifier

AM-7551-03

ADA 7551 BLOCK DIAGRAM

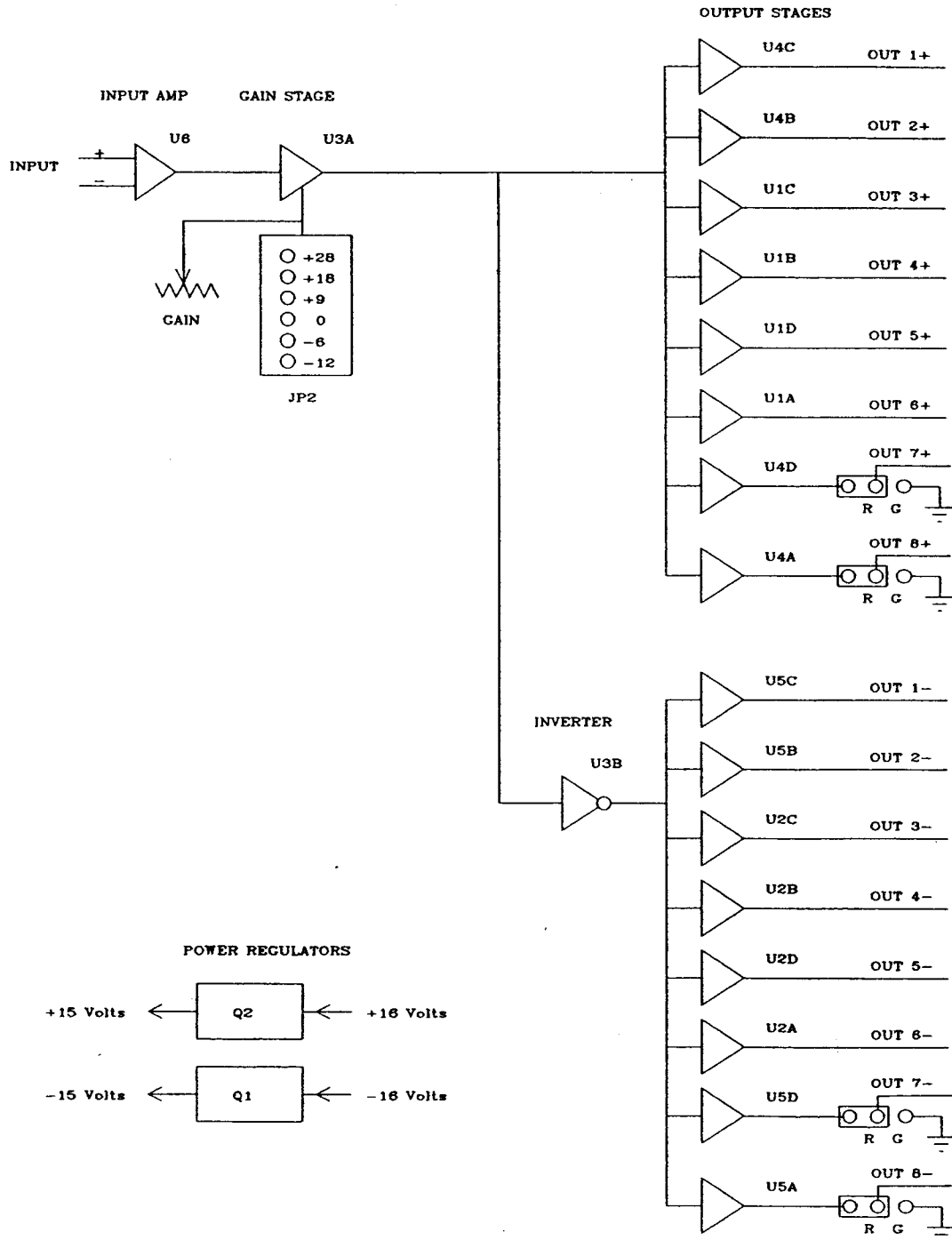

Introduction

The Ross ADA-7551 Audio Distribution Amplifier provides a means of amplifying and distributing program-level audio with virtually no loss of quality. Use of the latest types of integrated circuits which are developed specifically suited to professional audio applications assures a very low level of distortion and noise.

Installation

The card TRAY TYPE jumper (JP1) settings must be set before use. All jumper plugs must be set in a vertical row corresponding with the tray type designation as follows:



Ross Trays

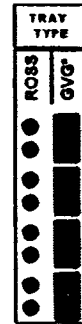

GVG* Trays

CAUTION:

If JP1 is not set correctly for a GVG tray, damage to the integrated circuits may occur.

Operation

Controls are provided for setting the gain of the amplifier.

The GAIN jumper plug is to be set for the desired gain range. In most installations it will be set to the 0 dB position to obtain unity gain.

The GAIN potentiometer provides a fine control of the gain and has a range of +/- 6dB.

There is no need to set the common mode BAL adjustment as it has been precisely factory pre-set and sealed. This amplifier incorporates an advanced type of input stage that does not have to be balanced for each installation.

Circuit Description

The input stage, U6, performs the function of converting the balanced input signal into an unbalanced (single ended) signal for further processing.

This stage is unique because it functions exactly as if the amplifier had a floating transformer input. This means that it responds only to the voltage difference between the two input lines and ignores any imbalance to ground. This gives the distribution amplifier the very desirable ability to accept any out-of-balance input signal and produce a perfectly balanced output. As a consequence, it also has an exceptional ability to reject common mode hum and noise over the whole audio band.

The input circuit includes diodes to protect the amplifier against damaging input noise spikes.

The amplifier gain is provided by circuit U3A. JP2 selects the desired gain range and RV1 provides vernier gain adjustment.

*GVG is a trademark of The Green Valley Group Inc.

ADA-7551 Audio Distribution Amplifier

The positive line outputs are driven by unity-gain stages U1 and U4. These circuits are designed to be very stable and not oscillate at any normal line load.

The negative output stages U2 and U5 are driven by unity-gain inverter U3B.

The power input voltage of approximately +/- 16 volts is reduced to +/- 15 volts by transistors Q2 and Q1. This lower voltage powers the input and gain stages while the output stages are fed directly from the power supply.

Alignment

The only alignment controls provided are for balancing the common-mode rejection of the input amplifiers. To adjust the BAL control, make the indicated connections to the terminal block associated with the particular amplifier.

NOTE:

Because this control has been precisely calibrated at the factory, it must not be adjusted unless U6 has been replaced.

1. Place the amplifier on the extender board.
2. Use a short jumper wire to connect the tray "input +" and "input -" terminals together.
3. Connect an audio generator between "input +" and ground. Set the generator frequency to 1 KHz and output level to +20 dBu.
4. Connect a balanced-input sensitive audio level meter or distortion analyser to a balanced pair of amplifier outputs.
5. With the output level meter set to the most sensitive scale, adjust the INPUT BAL potentiometer to obtain the lowest possible output level. It should be possible to obtain an output level of at least -80 dBu. (100dB below +20 dBu). Seal the pot.
6. Disconnect the test set up.

Specifications

Input	Input Impedance	>35K ohms, balanced
	Max Input Level	+34 dBu [+30 dBm]
	Common Mode Rejection	>100 dB @ 60 Hz >80 dB @ 20 KHz
Output	Number of Outputs	8
	Max Output Level	+28 dBu [+24 dBm]
	Output Impedance	48 ohms, [600 ohms]
	Output Isolation	>70 dB
Performance	S/N Ratio	>100 dB (unity gain) relative to +8 dBu
	Gain Range	-18 to +34 dB (± 6 dB fine adjustment)
	Frequency Response	+/- 0.02 dB 20 Hz to 20 KHz
	Total Harmonic Distortion	<0.002% [0.007%]
	Intermodulation	<0.002% [0.006%](SMPTE)
	Crosstalk between Amplifiers	>100 dB
	Power Consumption @ +8 dBu output	1.6 W [2.6 W]
<p>All tests performed at +18 dBu and cover 20 Hz to 20 KHz unless otherwise specified. All measurements made with an Audio Precision System One test set. Performance of the 600 ohm version is similar, except where indicated [].</p>		

ADA-7551 Audio Distribution Amplifier

ADA 7551
Bill of Materials

7551A-001

Item	QTY	REF	Part	Description	Part Number
1.	1	R48	NVR	NO VALUE, RESISTOR 5%	---
2.	16	R1,R3,R5,R7,R15,R17,R19, R21,R35,R36,R38,R41,R51, R53,R55,R57	NVR 1%	NO VALUE, RESISTOR 1%	---
3.	1	C18	22p	CAPACITOR, CERAMIC 100V 2% 22p	201-220
4.	3	C2,C8,C16	47p	CAPACITOR, CERAMIC 100V 2% 47p	201-470
5.	1	C4	4n7	CAPACITOR, CERAMIC 4n7	203-470
6.	1	C3	10n	CAPACITOR, CERAMIC 10n	204-100
7.	4	C1,C7,C11,C17	100n	CAPACITOR, GLASS 100n	225-100
8.	2	C6,C5	100u 250-005	CAPACITOR, TANTALUM 6.3V 100u	250-005
9.	2	C14,C12	47u	CAPACITOR, TANTALUM 16V 47u	250-006
10.	4	C9,C10,C13,C15	6u8	CAPACITOR, TANTALUM 25V 6u8	250-008
11.	1	J1	311-035	CONNECTOR, 2X25P, PCB MNT, 90 DEG	311-035
12.	4	CR1,CR2,CR3,CR4	1N4148	DIODE, SIGNAL GP 1N4148	360-005
13.	1	MP1	365-003	PCB, EJECTOR	365-003
14.	1	JP2	403-004-12	HEADER, 12 PIN, 2 ROW MALE, PL.23 BL.1 LL.1	403-004-12
15.	1	JP1	403-004-16	HEADER, 16 PIN, 2 ROW MALE, PL.23 BL.1 LL.1	403-004-16
16.	1	U3	NE5532N	INT-COMPENSATED, DUAL LO-NOISE OP, AMP	504-129
17.	1	U6	SSM-2143P	-6dB DIFFERENTIAL, LINE RECEIVER	504-130
18.	4	U1,U2,U4,U5	TLE2064CN	JFET-INPUT, HIGH-OUT POWER, QUAD OP AMP	504-155
19.	1				

20.	1	JPPLUG2			
21.	1	RV2	100R 1T	VARIABLE, RESISTOR, 1/4 DIA 1-TURN 100R	710-002
22.	1	RV1	10K 720-002	VARIABLE, RESISTOR, 20-TURN 10K	720-002
23.	1	PCB	7551-001-01	AUDIO, AMP	7551-001-01
24.	2	F2,F1	1R 1%	RESISTOR, 1/4W, 1% 1R	810-100
25.	1	R28	53R6 1%	RESISTOR, 1/4W, 1% 53R6	811-536
26.	1	R29	191R 1%	RESISTOR, 1/4W, 1% 191R	812-191
27.	1	R30	750R 1%	RESISTOR, 1/4W, 1% 750R	812-750
28.	1	R50	1K07 1%	RESISTOR, 1/4W, 1% 1K07	813-107

Notes

REVISION RECORD

REV.	DATE	BY	DESCRIPTION

- F1 = 0.5A FUSE
- F2 = 0.5A FUSE
- TP1 = TRAY TYPE
- TP2 = GAIN -12dB TO +20dB
- RV1 = GAIN
- RV2 = INPUT BAL
- TP3 = OUT +1
- TP4 = GND
- TP5 = -15V
- TP6 = +15V

MANUFACTURE THE BOARD TO THE SPECIFICATIONS OF THE ORIGINAL DESIGNER. THE BOARD IS TO BE MANUFACTURED TO THE SPECIFICATIONS OF THE ORIGINAL DESIGNER. THE BOARD IS TO BE MANUFACTURED TO THE SPECIFICATIONS OF THE ORIGINAL DESIGNER.

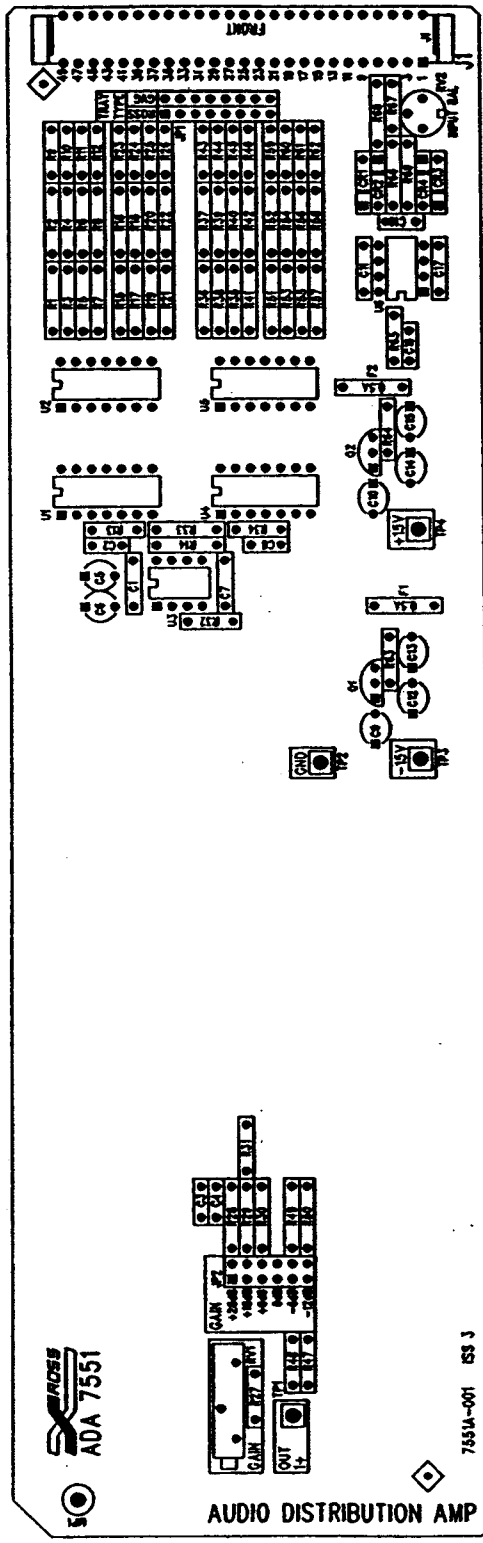

ROSS VIDEO LIMITED

ROSS VIDEO LIMITED
 AUDIO DISTRIBUTION AMP
 7551A-001
 7551A-001/A



ADA 7551

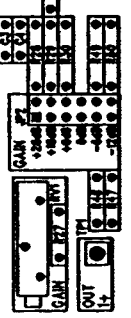

AUDIO DISTRIBUTION AMP

7551A-001 6S3 J



Ross™, ROSS™ are Trademarks of:

Copyright © 1995 by Ross Video Limited.
Printed in Canada.
All Rights reserved.
All specifications are subject to change without notice.

Ross Video Limited
8 John Street
Iroquois, Ontario
K0E 1K0

No part of this manual may be reproduced in any form
without prior written permission from Ross Video Limited.

DISTRIBUTION PRODUCTS WARRANTY and REPAIR POLICY

- 1.** Ross Video Limited (the Company) warrants its products to be free from defects in workmanship and material under normal use and service for a period of **FIVE** years from the date of shipment. If, within the warranty period, the customer notifies the Company that a product is defective, the Company will correct the defect, either by repairing the defective product or by shipping a replacement product to the customer, as determined by the Company.
- 2.** Liabilities under this warranty is limited to the repair or replacement of the product as determined by the Company and is in lieu of all other warranties expressed or implied.
- 3.** This warranty does not extend to any product which has been subjected to misuse, neglect, accident, improper installation or application, nor does it extend to products which have been repaired or altered outside the factory by personnel other than those of the Company, unless expressly authorised in writing by the Company.
- 4.** Warranty repairs will be made at the Company's plant unless otherwise specified in writing by the Company. All packing, shipping, and special handling costs will be paid for by the customer.
- 5.** Non-warranty repair service made at the factory will be at customer expense. Cost of repairs will be quoted following examination of the product by Company personnel.
- 6.** In no event shall Ross Video Limited be liable for direct, indirect, special, incidental, or consequential damages (including loss of profits).