

SRA-8802

Single 3G/HD/SD Reclocking Distribution Amplifier User Manual

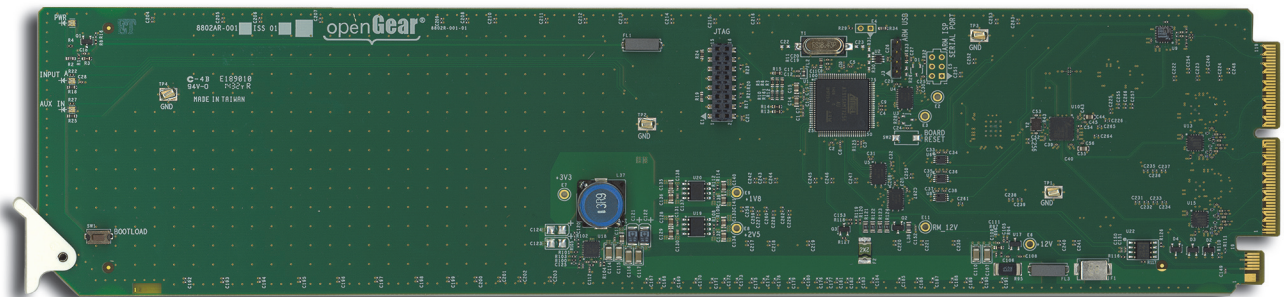

Thank You for Choosing Ross

You've made a great choice. We expect you will be very happy with your purchase of Ross Technology.

Our mission is to:

1. Provide a Superior Customer Experience
 - offer the best product quality and support
2. Make Cool Practical Technology
 - develop great products that customers love

Ross has become well known for the Ross Video Code of Ethics. It guides our interactions and empowers our employees. I hope you enjoy reading it below.

If anything at all with your Ross experience does not live up to your expectations be sure to reach out to us at solutions@rossvideo.com.



David Ross
CEO, Ross Video
dross@rossvideo.com

Ross Video Code of Ethics

Any company is the sum total of the people that make things happen. At Ross, our employees are a special group. Our employees truly care about doing a great job and delivering a high quality customer experience every day. This code of ethics hangs on the wall of all Ross Video locations to guide our behavior:

1. We will always act in our customers' best interest.
2. We will do our best to understand our customers' requirements.
3. We will not ship crap.
4. We will be great to work with.
5. We will do something extra for our customers, as an apology, when something big goes wrong and it's our fault.
6. We will keep our promises.
7. We will treat the competition with respect.
8. We will cooperate with and help other friendly companies.
9. We will go above and beyond in times of crisis. *If there's no one to authorize the required action in times of company or customer crisis - do what you know in your heart is right. (You may rent helicopters if necessary.)*

SRA-8802 · User Manual

- Ross Part Number: 8802DR-004-04
- Release Date: January 18, 2018.

The information contained in this Guide is subject to change without notice or obligation.

Copyright

©2018 Ross Video Limited, Ross®, and any related marks are trademarks or registered trademarks of Ross Video Limited. All other trademarks are the property of their respective companies. PATENTS ISSUED and PENDING. All rights reserved. No part of this publication may be reproduced, stored in a retrieval system, or transmitted in any form or by any means, mechanical, photocopying, recording or otherwise, without the prior written permission of Ross Video. While every precaution has been taken in the preparation of this document, Ross Video assumes no responsibility for errors or omissions. Neither is any liability assumed for damages resulting from the use of the information contained herein.

Patents

Patent numbers US 7,034,886; US 7,508,455; US 7,602,446; US 7,802,802 B2; US 7,834,886; US 7,914,332; US 8,307,284; US 8,407,374 B2; US 8,499,019 B2; US 8,519,949 B2; US 8,743,292 B2; GB 2,419,119 B; GB 2,447,380 B; and other patents pending.

Notice

The material in this manual is furnished for informational use only. It is subject to change without notice and should not be construed as commitment by Ross Video Limited. Ross Video Limited assumes no responsibility or liability for errors or inaccuracies that may appear in this manual.

Safety Notices

Refer to the “**Important Regulatory and Safety Notices**” document that accompanied your product.

Statement of Compliance

This product has been determined to be compliant with the applicable standards, regulations, and directives for the countries where the product is marketed.

Compliance documentation, such as certification or Declaration of Compliance for the product is available upon request by contacting techsupport@rossvideo.com. Please include the product; model number identifiers and serial number and country that compliance information is needed in request.

EMC Notices

US FCC Part 15

This equipment has been tested and found to comply with the limits for a class A Digital device, pursuant to part 15 of the FCC Rules.

These limits are designed to provide reasonable protection against harmful interference when the equipment is operated in a Commercial environment. This equipment generates, uses, and can radiate radio frequency energy and, if not installed and used in accordance with the instruction manual, may cause harmful interference to radio

communications. Operation of this equipment in a residential area is likely to cause harmful interference in which case the user will be required to correct the interference at his own expense.

Notice — *Changes or modifications to this equipment not expressly approved by Ross Video Ltd. could void the user's authority to operate this equipment.*

Canada

This Class “A” digital apparatus complies with Canadian ICES-003 and part 15 of the FCC Rules.

Cet appareil numérique de la classe “A” est conforme a la norme NMB-003 du Canada.

European Union

This equipment is in compliance with the essential requirements and other relevant provisions established under regulation (EC) No 765/2008 and Decision No 768/2008/EC referred to as the “New Legislative Framework”.



Warning — *This equipment is compliant with Class A of CISPR 32. In a residential environment this equipment may cause radio interference.*

Australia/New Zealand

This equipment is in compliance with the provisions established under the Radiocommunications Act 1992 and Radiocommunications Labeling (Electromagnetic Compatibility) Notice 2008.

Korea

This equipment is in compliance with the provisions established under the Radio Waves Act.

Class A equipment (Broadcasting and communications service for business use)

This device is a business-use (Class A) EMC-compliant device. The seller and user are advised to be aware of this fact. This device is intended for use in areas outside home.

Type of Equipment	User's Guide
A급 기기 (업무용 방송통신기자재)	이 기기는 업무용(A급) 전자파적합기기로서 판매자 또는 사용자는 이 점을 주의하시기 바라며, 가정외의 지역에서 사용하는 것을 목적으로 합니다.
Class A Equipment (Industrial Broadcasting & Communication Equipment)	This equipment is Industrial (Class A) electromagnetic wave suitability equipment and seller or user should take notice of it, and this equipment is to be used in the places except for home.

International

This equipment has been tested under the requirements of CISPR 22:2008 or CISPR 32:2015 and found to comply with the limits for a Class A Digital device.

Notice — *This is a Class A product. In domestic environments, this product may cause radio interference, in which case the user may have to take adequate measures.*

Maintenance/User Serviceable Parts

Routine maintenance to this openGear product is not required. This product contains no user serviceable parts. If the module does not appear to be working properly, please contact Technical Support using the numbers listed under the “**Contact Us**” section of this manual. All openGear products are covered by a generous 5-year warranty

and will be repaired without charge for materials or labor within this period. See the “**Warranty and Repair Policy**” section in this manual for details.

Environmental Information

The equipment may contain hazardous substances that could impact health and the environment.

To avoid the potential release of those substances into the environment and to diminish the need for the extraction of natural resources, Ross Video encourages you to use the appropriate take-back systems. These systems will reuse or recycle most of the materials from your end-of-life equipment in an environmentally friendly and health conscious manner.

The crossed-out wheeled bin symbol invites you to use these systems.



If you need more information on the collection, reuse, and recycling systems, please contact your local or regional waste administration. You can also contact Ross Video for more information on the environmental performances of our products.

Company Address



Ross Video Limited

8 John Street
Iroquois, Ontario, K0E 1K0
Canada

Ross Video Incorporated

P.O. Box 880
Ogdensburg, New York
USA 13669-0880

General Business Office: (+1) 613 • 652 • 4886

Fax: (+1) 613 • 652 • 4425

Technical Support: (+1) 613 • 652 • 4886

After Hours Emergency: (+1) 613 • 349 • 0006

E-mail (Technical Support): techsupport@rossvideo.com

E-mail (General Information): solutions@rossvideo.com

Website: <http://www.rossvideo.com>

Contents

- Introduction 1**
 - Overview..... 1-2
 - Features..... 1-2
 - Functional Block Diagrams 1-3
 - Single 1x8 Configuration 1-3
 - Single 1x8 Configuration with Bypass Relay 1-3
 - User Interfaces 1-5
 - DashBoard Control System 1-5
 - Card-edge Monitoring 1-5
 - SNMP Monitoring and Control 1-5
 - Documentation Terms and Conventions..... 1-6

- Installation 2**
 - Before You Begin 2-2
 - Static Discharge 2-2
 - Unpacking..... 2-2
 - Installing the SRA-8802 2-3
 - Supported Rear Modules 2-3
 - Installing a Card 2-3
 - Cabling..... 2-5
 - Software Upgrades..... 2-7

- Configuration 3**
 - Card Overview 3-2
 - Monitoring Features..... 3-3
 - Status LEDs 3-3
 - Using DashBoard..... 3-5
 - Configuring the SRA-8802 3-6
 - Enabling the Failover Feature 3-6
 - Configuring the Equalizer 3-7
 - Configuring the Reclocker 3-7
 - Loss of Input..... 3-8

- DashBoard Menus 4**
 - Status Tabs 4-2
 - Signal Tab..... 4-2
 - Hardware Tab 4-4
 - Product Tab 4-4
 - Setup Tab 4-5
 - Alarms Tab 4-6

- Specifications 5**
 - Technical Specifications 5-2

Service Information

6

Troubleshooting Checklist	6-2
Bootload Button	6-2
Warranty and Repair Policy	6-3

Introduction

In This Chapter

This chapter contains the following sections:

- Overview
- Functional Block Diagrams
- User Interfaces
- Documentation Terms and Conventions

A Word of Thanks

Congratulations on choosing an openGear SRA-8802 3G/HD/SD Reclocking Amplifier. Thank you for joining the group of worldwide satisfied Ross Video customers!

Should you have a question pertaining to the installation or operation of your SRA-8802, please contact us at the numbers listed on the back cover of this manual. Our technical support staff is always available for consultation, training, or service.

Overview

Your SRA-8802 is a 3G/HD/SD Multi-Definition SDI distribution amplifier, capable of equalizing and reclocking all common serial digital signals. The outputs are non-inverting making it an excellent ASI distribution amplifier. An LED indicator at the front of the card identifies the presence of incoming video, simplifying system troubleshooting.

Features

The SRA-8802 includes the following features:

- Equalizes and reclocks SDI signals of 270Mbps, 1.485Gbps, and 2.97Gbps
- Accepts DVB-ASI (EN 50083-9), and SMPTE 310 signals
- Flexible channel configurations:
 - › Operate as a single 1x8 with a backup input for auto fail-over (*requires the 8320AR-300 Full Rear Modules*)
 - › Operate as a single 1x8 with a backup input for auto fail-over and a bypass relay between SDI IN and OUT 1 (*requires the 8320AR-306 Full Rear Modules*)
 - › Operate as a single 1x4 (*requires the 8320AR-301 Split Rear Module*)
- Configure and monitor via DashBoard
- Automatic detection of incoming data rate
- Automatically mutes the channel output when a loss of input occurs
- Automatically performs a fail-over switch between the two SDI inputs (*requires the 8320AR-300, or 8320AR-306 Full Rear Modules*)
- All outputs are non-inverting
- LED indicator for signal presence
- Excellent input and output return loss
- Fits DFR-8321 and OG3-FR series frames
- Fully compliant with openGear specifications
- 5 year transferable warranty

Functional Block Diagrams

The SRA-8802 can operate as a re-clocking single 1x8 or as a single 1x4 amplifier. The configuration depends on the rear module you are using. This section provides the block diagrams for all configurations.

Single 1x8 Configuration

Figure 1.1 describes the workflow of the SRA-8802 with the 8320AR-300 Full Rear module. This configuration has the SRA-8802 operating as a single re-clocking 1x8 with BNC connections.

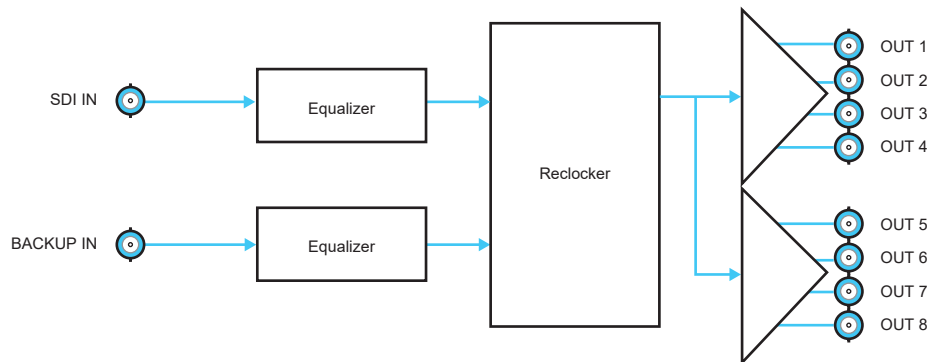

Figure 1.1 Simplified Diagram — 1x8 Configuration (8320AR-300)

Single 1x8 Configuration with Bypass Relay

Figure 1.2 describes the workflow of the SRA-8802 with the 8320AR-306 Full Rear module. This configuration has the SRA-8802 operating as a single re-clocking 1x8 with BNC connections.

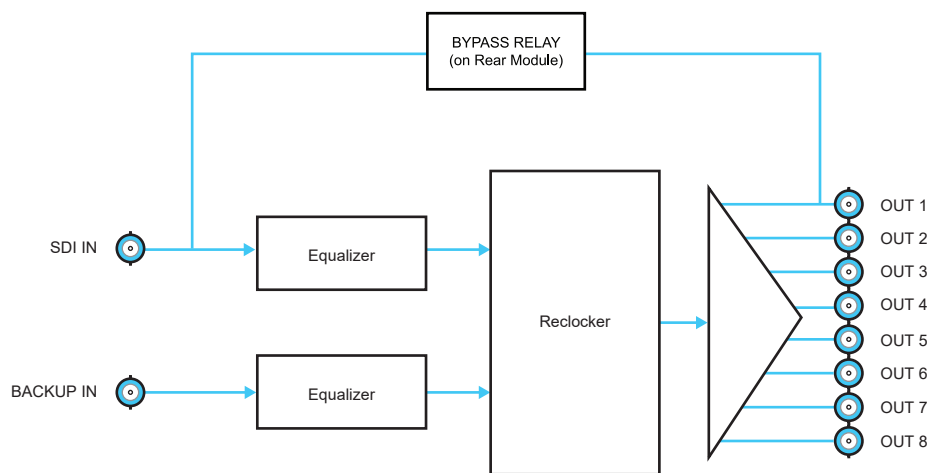

Figure 1.2 Simplified Diagram — 1x8 Configuration (8320AR-306)

Single 1x4 Configuration

Figure 1.3 describes the workflow of the SRA-8802 with the 8320AR-301 Split Rear module. This configuration has the SRA-8802 operating as a single re-clocking 1x4 with BNC connections.

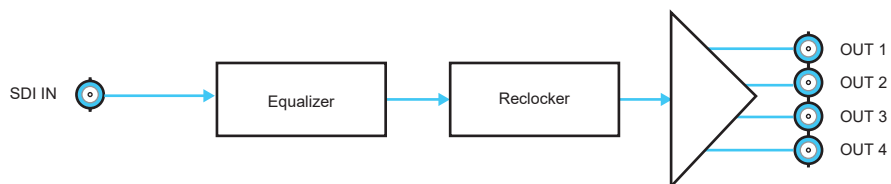

Figure 1.3 Simplified Diagram — 1x4 Configuration (8320AR-301)

User Interfaces

The following interfaces are available for control and monitoring of your SRA-8802.

DashBoard Control System

DashBoard enables you to monitor and control openGear frames and cards from a computer. DashBoard communicates with other cards in the openGear frame through the Network Controller card.

For More Information on...

- the menus in DashBoard, refer to the chapter “**DashBoard Menus**” on page 4-1.
- installing and using DashBoard, refer to the *DashBoard User Manual*.

Card-edge Monitoring

The card-edges provide LEDs for monitoring the status of the input signal.

For More Information on...

- the card-edge LEDs, refer to the section “**Monitoring Features**” on page 3-3.

SNMP Monitoring and Control

The Network Controller card in the openGear frame provides optional support for remote monitoring and control of your frame and openGear cards using Simple Network Management Protocol (SNMP), which is compatible with many third-party monitoring and control tools.

For More Information on...

- SNMP controls on your card, refer to your SRA-8802 Management Information Base (MIB) file.
- SNMP Monitoring and Control, refer to your *MFC-8300 Series or MFC-OG3 Series User Manual*.

Documentation Terms and Conventions

The following terms and conventions are used throughout this manual.

Terms

The following terms are used:

- “**Board**” and “**Card**” both refer to the card, including all components and switches.
- “**DashBoard**” refers to the DashBoard Control System.
- “**DFR-8321 series**” refers to the DFR-8321 series frames and all available options unless otherwise indicated.
- “**Network Controller Card**” refers to the MFC-8320-N, MFC-8322-N, and MFC-OG3-N Series Network Controller Cards unless otherwise indicated.
- “**OG3-FR series**” refers to the OG3-FR series frames and all available options unless otherwise indicated.
- “**openGear frame**” refers to the DFR-8321 series and OG3-FR series frames and all available options unless otherwise indicated.
- “**Operator**” and “**User**” both refer to the person who uses the SRA-8802.
- “**System**” and “**Video system**” both refer to the mix of interconnected production and terminal equipment in which the card operates.

Conventions

The following conventions are used:

- The “**Operating Tips**” and “**Note**” boxes are used to provide additional user information.

Installation

In This Chapter

This chapter provides instructions for installing the rear module for your SRA-8802, installing the card in the frame, cabling details, and how to upgrade the software on your card(s).

The following topics are discussed:

- Before You Begin
- Installing the SRA-8802
- Cabling
- Software Upgrades

Before You Begin

Before proceeding with the instructions in this chapter, ensure that your openGear frame is properly installed according to the instructions in its manual.

Static Discharge

Throughout this chapter, please heed the following cautionary note:



ESD Susceptibility — *Static discharge can cause serious damage to sensitive semiconductor devices. Avoid handling circuit boards in high static environments such as carpeted areas and when synthetic fiber clothing is worn. Always exercise proper grounding precautions when working on circuit boards and related equipment.*

Unpacking

Unpack each card you received from the shipping container and ensure that all items are included. If any items are missing or damaged, contact your sales representative or Ross Video directly.

Installing the SRA-8802

The SRA-8802 can be installed in the DFR-8321 series frames and the OG3-FR series frames using one of the supported rear modules. The procedure for installing the rear module and card in your openGear frame is the same regardless of the rear module used.

Supported Rear Modules

Notice — *Ensure that you install the SRA-8802 using one of the supported rear modules listed below. Installing the SRA-8802 with an unsupported rear module can damage the card, the rear module, or both.*

The Rear Module depends on the configuration you wish to use:

- **1x8 configuration** — The **8320AR-300**, or **8320AR-306** Full Rear Module is required.
- **1x4 configuration** — The **8320AR-301** Split Rear Module is required.

Installing a Card

You must first install the rear module in the frame and then install the card in the appropriate slot within an openGear frame. This section outlines how to perform both tasks.

To install the rear module in the openGear frame

1. Ensure that the frame is properly installed.
2. On the rear of the frame, locate the card frame slot.
3. Remove the Blank Plate from the rear of the slot you have chosen for card installation.
4. As shown in **Figure 2.1**, seat the bottom of the rear module in the seating slot at the base of the frame's back plane.

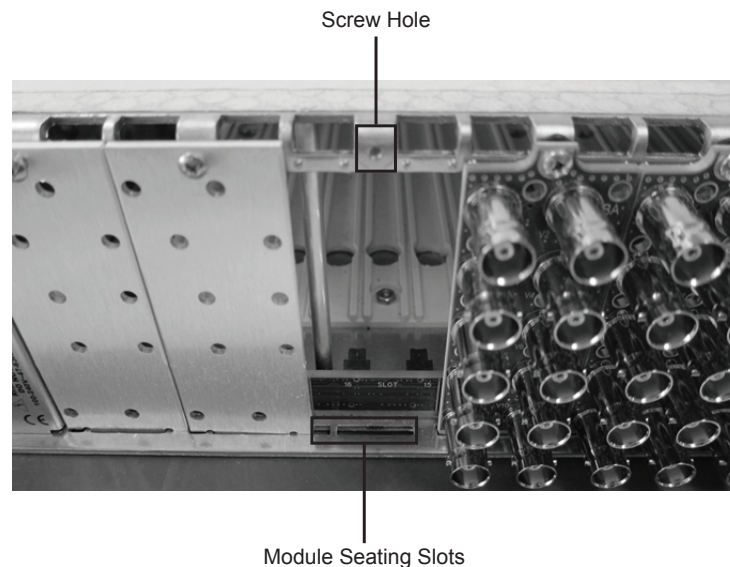

Figure 2.1 Rear Module Installation in an OG3-FR Series Frame (Cards not shown)

5. Align the top hole of the rear module with the screw hole on the top edge of the frame back plane.

6. Using a Phillips screwdriver and the supplied screw, fasten the rear module to the back plane. Do not over-tighten.
7. Verify whether your Rear Module Label is self-adhesive by checking the back of the label for a thin wax sheet. You must remove the wax sheet before affixing the label.
8. Affix the supplied Rear Module Label to the BNC area of the Rear Module.
9. Ensure proper frame cooling and ventilation by having all rear frame slots covered with rear modules or blank metal plates.

To install the card in the openGear frame

1. Locate the Rear Module you installed in the procedure “**To install the rear module in the openGear frame**” on page 2-3.
2. Hold the card by the edges and carefully align the card edges with the slots in the frame.
3. Fully insert the card into the frame until the rear connection plugs are properly seated on the midplane and rear modules.

Cabling

The SRA-8802 can operate as a single 1x8, or as a single 1x4 depending on the rear module you are using. This section provides cabling details for each supported configuration.

Single 1x8 Configurations

The 8320AR-300 Full Rear Module is required when operating as a single 1x8 configuration. Each rear module occupies two slots and accommodates one card. This rear module provides an SDI input, a backup input, and eight SDI outputs via BNC connections. (**Figure 2.2**)

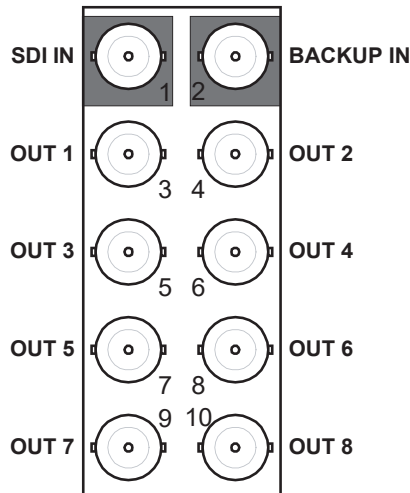

Figure 2.2 Cable Connections for the 8320AR-300 Full Rear Module

Single 1x8 Configuration with Bypass Relay

The 8320AR-306 Full Rear Module is required when operating as a single 1x8 configuration with a bypass relay. Each rear module occupies two slots, and accommodates one card. This rear module provides one SDI input, a backup input, and eight SDI outputs via BNC connections. A bypass relay between SDI IN and OUT 1 is also provided. (**Figure 2.3**)

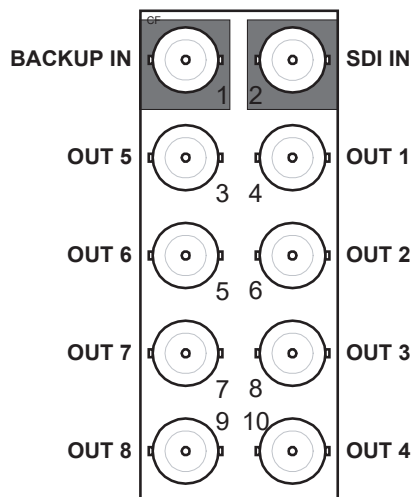

Figure 2.3 Cable Connections for 8320AR-306 Full Rear Module

Single 1x4 Configuration

The 8320AR-301 Split Rear Module is required when operating as a single 1x4 configuration. Each rear module occupies two slots, and accommodates two cards. This rear module provides one SDI input, and four SDI outputs via BNC connections per card. (**Figure 2.4**)

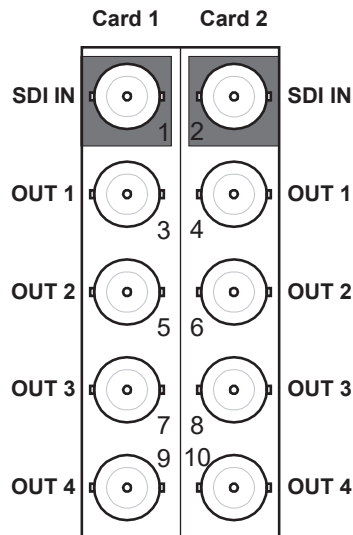

Figure 2.4 Cable Connections for the 8320AR-301 Split Rear Module

Software Upgrades

The SRA-8802 can be upgraded in the field via the Network Controller Card in your openGear frame. Note that DashBoard version 6.2.0 or higher is required.

To upgrade the software on a card

1. Contact Ross Technical Support for the latest software version file.
2. Display the **Device View** of the card by double-clicking its status indicator in the **Basic Tree View**.
3. From the **Device View**, click **Upload** to display the **Select file for upload** dialog.
4. Navigate to the *.bin upload file you wish to upload.
5. Click **Open**.
6. If you are upgrading a single card, click **Finish** to display the **Uploading to Selected Devices** dialog. Proceed to step 8.
7. If you are upgrading multiple cards:
 - Click **Next >** to display the **Select Destination** menu. This menu provides a list of the compatible cards based on the card selected in step 2.
 - Specify the card(s) to upload the file to by selecting the check box(es) for the cards you wish to upload the file to.
 - Verify that the card(s) you wish to upload the file to. The **Error/Warning** fields indicate any errors, such as incompatible software or card type mismatch.
 - Click **Finish** to display the **Uploading to Selected Devices** dialog.
8. Monitor the upgrade.
 - The **Uploading to Selected Devices** dialog enables you to monitor the upgrade process.
 - Click **OK** to complete the upgrade.
 - The card(s) are temporarily taken offline during the re-boot process. The process is complete once the status indicators for the **Card State** and **Connection** fields return to their previous status.

Configuration

In This Chapter

This chapter provides a general overview of the user controls available on your SRA-8802.

The following topics are discussed:

- Card Overview
- Monitoring Features
- Using DashBoard
- Configuring the SRA-8802

Card Overview

This section describes the **Bootload** button located on the card surface. There are no other card-edge controls as all configuration and setup is done using the menus in DashBoard. Refer to **Figure 3.1** for location of this button.

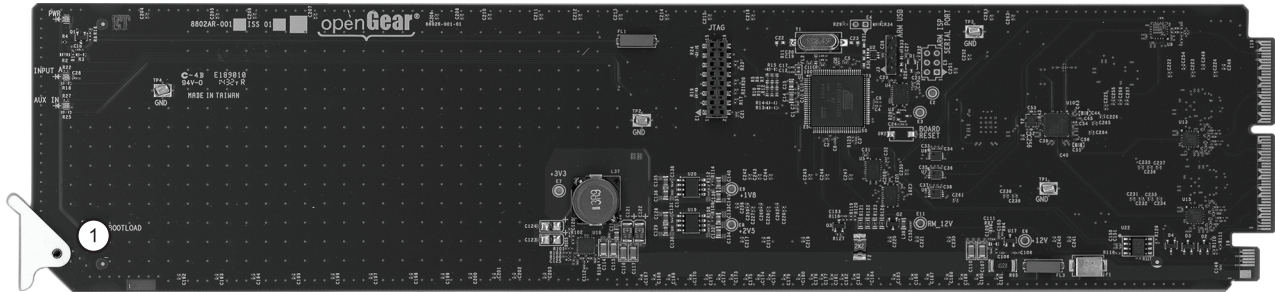

Figure 3.1 Card-edge Controls

1. Bootload Button

This button is used for factory service in the unlikely event of a complete card failure. Do not use this button unless advised by Ross Technical Support.

For More Information on...

- the Bootload process, refer to the section “**Bootload Button**” on page 6-2.

Monitoring Features

The following sections describe the card-edge LEDs. Refer to **Figure 3.2** for LED locations.

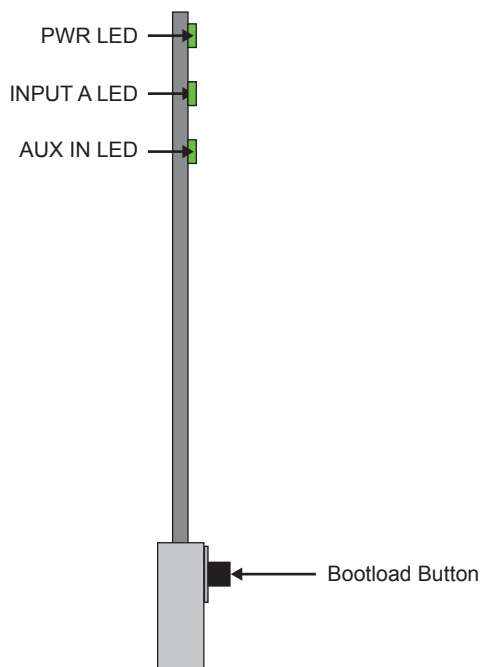

Figure 3.2 LED Locations

Status LEDs

Basic LED displays and descriptions are provided in **Table 3.1**.

Table 3.1 Status LEDs

LED	Color	Display and Description
PWR	Green	When lit green, this LED indicates that the card is functioning normal and that no anomalies have been detected.
	Flashing Green	When flashing green, this LED indicates that the Bootload button was pressed, and the card is receiving a new software load from the frame.
	Flashing Green and Orange	When lit green with flashing orange, this LED indicates a signal or configuration problem. Verify the signal status and settings.
	Amber	When lit amber, this LED indicates the card is running internal diagnostics while powering up.
	Red	When lit red or flashing red, this LED indicates the card is not operational. Re-seat card in frame, check the rear module type and connections, or call Ross Video Technical Support.
	Off	When off, this LED indicates there is no power to the card.
INPUT A	Green	When lit green, this LED indicates that a valid SDI input signal is present on Channel A.
	Red	When lit red, this LED indicates that the SDI input signal is missing or invalid on Channel A.

Table 3.1 Status LEDs

LED	Color	Display and Description
AUX IN	Green	When lit green, this LED indicates a valid SDI signal on the BACKUP IN BNC.
	Red	When lit red, this LED indicates that the SDI input signal is missing or invalid on the BACKUP IN BNC.

Using DashBoard

Before proceeding, ensure that the DashBoard client software is installed on a computer connected to your facility network. The DashBoard software and user manual area available from the Ross Video website.

For More Information on...

- installing DashBoard, refer to the *DashBoard User Manual*.

To launch DashBoard

- Ensure that you are running DashBoard software version 6.2.0 or higher.
- Launch DashBoard by double-clicking its icon on your desktop.
- Ensure that the openGear frame with your SRA-8802 card(s) is displayed in the Tree View located on the left-side of the DashBoard window.

It may take 30 seconds or more to update the Tree View. Consult the *MFC-8300 Series* or *MFC-OG3 Series User Manual* and *DashBoard User Manual* should the Tree View not display the card.

To access a card in DashBoard

- From the **Tree View**, expand the node for the openGear frame your cards are installed in. A list of cards installed in the frame is now displayed. In the example below, the node for Frame 6 is expanded to show a list of cards including the SRA-8802.
- Double-click the node for a card to display its menus in the **Device View** of DashBoard (right-side of the DashBoard window).

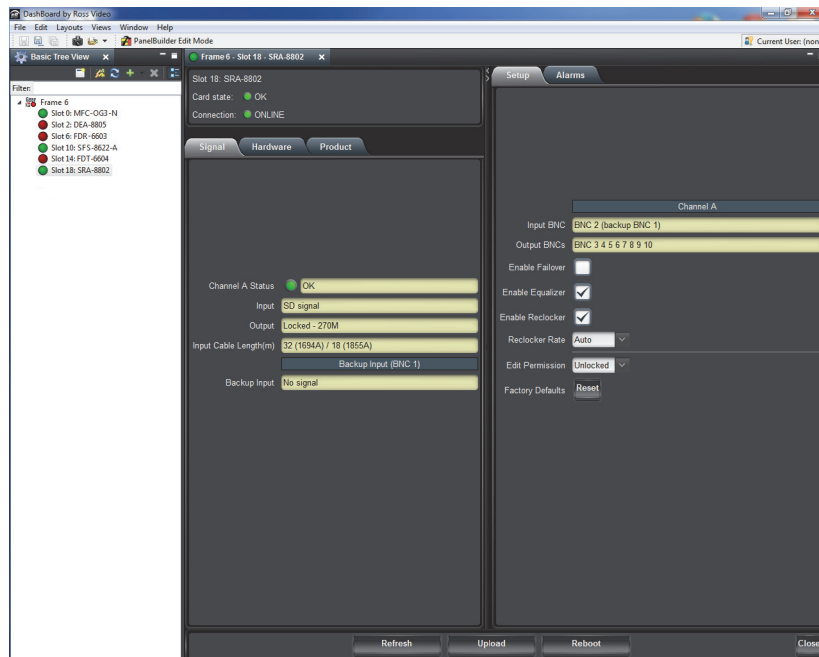

Example of a SRA-8802 in DashBoard

Configuring the SRA-8802

This section briefly outlines how to configure the SRA-8802 using the options available in DashBoard.

Enabling the Failover Feature

The failover feature enables the SRA-8802 to use a backup input source when the primary input source is lost and the backup input is stable for at least 3 seconds. Once the SRA-8802 determines that the primary input source is stable for at least 3 seconds, it automatically switches back to the primary source. The **Input** field on the **Signal** tab reports when the backup source is in use for Channel A.



Note — *The Failover Feature requires that the SRA-8802 be installed with an 8320AR-300, or 8320AR-306 Full Rear Module.*

The source assignments are fixed for Channel A as follows:

- Channel A — SDI IN is the primary input source and BACKUP IN is the backup source.

To enable the failover feature

1. From the **Device View**, select the **Setup** tab.

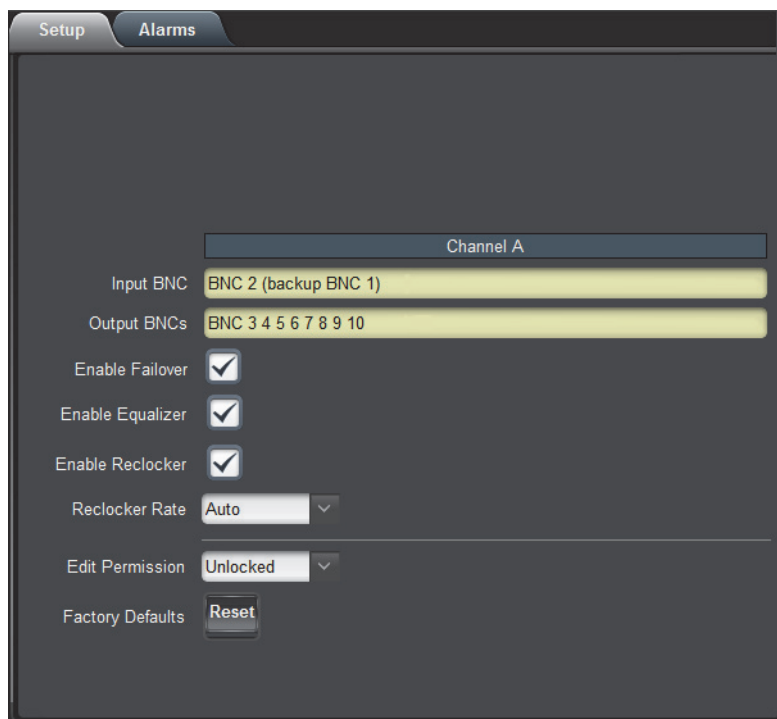

Setup Tab — Enabling the Failover Feature

2. Select the **Enable Failover** box. The box displays a check-mark.

Configuring the Equalizer

You can choose to enable or bypass the equalizer on the card. The equalizer enables the card to compensate for noise and signal losses inherent in long coaxial cable runs. Refer to the chapter “**Specifications**” on page 5-1 for information on the cable equalization specifications.



Note — *You must bypass the equalizer when using signals of less than 125Mbps (such as SMPTE 310 signals). For signals 125Mbps and greater (such as SDI signals), you must enable the equalizer.*

To enable the equalizer

1. From the **Device View**, select the **Setup** tab.
2. Select the **Enable Equalizer** box. The box displays a check-mark.

To bypass the equalizer

1. From the **Device View**, select the **Setup** tab.
2. Select the **Enable Equalizer** box to clear the box contents.

Configuring the Reclocker

This section summarizes how to enable the reclocker and select a data rate for the reclocker. This enables the card to reclock to a specific data rate or automatically detects and reclocks the data rate. It also sets the input signal rate type that the SRA-8802 will process.

To enable the reclocker

1. From the **Device View**, select the **Setup** tab.
2. Select the **Enable Reclocker** box. The box displays a check-mark.
3. Use the **Reclocker Rate** menu to choose a data rate. Choose from the following:
 - **Auto** — The SRA-8802 reclocks at the detected rate automatically.
 - **270 Mbps** — The SRA-8802 is set to reclock at 270Mbps only.
 - **1.5 Gbps** — The SRA-8802 is set to reclock at 1.5Gbps only.
 - **3.0 Gbps** — The SRA-8802 is set to reclock at 2.97Gbps only.

To bypass the reclocker



Note — *You must bypass the reclocker when using DVB-ASI, or SMPTE 310 signals.*

1. From the **Device View**, select the **Setup** tab.
2. Select the **Enable Reclocker** check box to clear the box contents.

Loss of Input

When enabled, this feature will indicate an alarm condition (red) in the **Channel Status** field of the **Signal** tab. This occurs if the SRA-8802 does not detect a valid input signal for that channel. To verify which BNC to troubleshoot, refer to the rear module labeling or the **Input BNC** status field in the **Setup** tab.

To enable an alarm for a loss of input

1. From the **Device View**, select the **Alarms** tab.
2. Select the **Alarm on Loss of Input** check box. The box displays a check-mark.

DashBoard Menus

In This Chapter

This chapter briefly summarizes the menus, items, and parameters available from DashBoard for your card. Default parameters are noted with an asterisk (*).

The following topics are discussed:

- Status Tabs
- Setup Tab
- Alarms Tab



Operating Tip — *Wait 30 seconds after the last setting change to ensure all changes are saved to the non-volatile memory of the card.*

Status Tabs

This section summarizes the read-only information displayed in the **Status** tabs. The fields in the **Status** tabs can vary in severity from green (valid), yellow (caution), to red (alarm). DashBoard reports the most severe alarm for a single field. Alarm colors are noted within the tables as text set in brackets next to the menu parameter name.

Signal Tab

Table 4.1 outlines the read-only information displayed in the **Signal** tab.

Table 4.1 Signal Tab Items

Tab Title	Item	Parameters	Description
Channel A	Channel A Status	OK (Green)	A valid input signal is detected
		No input (Red)	Input signal is not present. The Alarm on Loss of Input for this channel is enabled.
		No input (Green)	Input signal is not present. The Alarm on Loss of Input for this channel is disabled.
	Input	No signal	Input signal is not present
		<125mB/s signal	A signal detected at less than 125Mbps is present
		<125mB/s signal (backup)	A signal of less than 125Mbps is present from the backup source (BACKUP IN)
		SD signal	A valid 270Mbps input signal is present
		SD signal (backup)	A valid 270Mbps input signal is present from the backup source (BACKUP IN)
		HD signal	A valid 1.485Gbps input signal is present
		HD signal (backup)	A valid 1.485Gbps input signal is present from the backup source (BACKUP IN)
		3G signal	A valid 2.97Gbps input signal is present
		3G signal (backup)	A valid 2.97Gbps input signal is present from the backup source (BACKUP IN)
		Equalizer bypassed	Input signal is present and the equalizer is bypassed (the Enable Equalizer check box is not selected in the Setup tab)
	Output	Locked - 270Mbps	Reclocker locks at 270Mbps
		Locked - 1.5Gbps	Reclocker locks at 1.485Gbps
		Locked - 3.0Gbps	Reclocker locks at 2.97Gbps
		Unlocked (muted)	Reclocker is enabled and unlocked. The output is automatically muted.
		Reclocker bypassed	Input signal is present and the reclocker is bypassed (the Enable Reclocker check box is not selected in the Setup tab)
No signal (muted)		Input signal is not present. The output is automatically muted.	

Table 4.1 Signal Tab Items

Tab Title	Item	Parameters	Description
Channel A	Input Cable Length (m)	x (1694A) / y (1855A)	Indicates the approximate cable length used for the input signal where: <ul style="list-style-type: none"> • x represents the Belden 1694A length • y represents the Belden 1855A length
		N/A	One of the following is occurring: <ul style="list-style-type: none"> • a valid input source was not detected on the input BNC • the Enable Equalizer check box is not selected in the Setup tab
Backup Input^a	Backup Input	No signal	The backup input signal is not present
		SD signal	A valid 270Mbps signal is present for the backup input
		HD signal	A valid 1.485Gbps signal is present for the backup input
		3G signal	A valid 2.97Gbps signal is present for the backup input
		Equalizer bypassed	Backup input signal is present and the equalizer is bypassed (the Enable Equalizer check box is not selected in the Setup tab)

a. This information is only available when the SRA-8802 is installed with a 8320AR-300, or 8320AR-306 full rear module.

Hardware Tab

Table 4.2 outlines the read-only information displayed in the **Hardware** tab.

Table 4.2 Hardware Tab Items

Tab Title	Item	Parameters	Description
Hardware	HW Status	OK (Green)	The rear module installed with the card is supported and the card is operating correctly
		Incomp Rear Module (Red)	One of the following is occurring: <ul style="list-style-type: none"> • an unsupported rear module is installed with the card • the card is installed in the wrong frame slot (where the card does not align with the connector on the rear module)
	Voltage (mV)	#	Supply voltage
	Current (mA)	#	Current consumption of card in milliAmperes
	CPU Headroom	#	Processing power available
	RAM Available	#	On-board processing memory available
	Uptime (h)	#	Displays the number of hours since the last reboot of the card
	Configuration Bank	#	Storage count

Product Tab

Table 4.3 outlines the read-only information displayed in the **Product** tab.

Table 4.3 Product Tab Items

Tab Title	Item	Parameters	Description
Product	Product	SRA-8802	Displays the card model
	Supplier	Ross Video Ltd.	Indicates the manufacturer of your card
	Board Rev	###	Indicates the version of the PCB
	Board S/N	#####	Indicates the card serial number
	Rear Module	#	Indicates the installed rear module
		Unknown	Indicates that the installed rear module is not recognized by the card
	Software Rev	###.###	Indicates the software version

Setup Tab

Table 4.4 summarizes the Setup options available in DashBoard.

Table 4.4 Setup Menu Items

Menu Title	Item	Parameters	Description
Channel A	Input BNC	# (read-only)	Indicates the BNC on the rear module that is assigned as the input source
		N/C	Indicates that no BNCs are currently used as inputs
	Output BNCs	# (read-only)	Indicates the BNCs on the rear module that are assigned as the outputs
		N/C	Indicates that there are no outputs in this channel
	Enable Failover ^a	Selected	Channel A will use the Backup input when the primary input of the channel is lost. The Backup input signal must be stable for 3 seconds. Note that the card returns to the primary input once the primary input signal is stable for 3 seconds.
		Cleared*	Disables this feature
	Enable Equalizer	Selected*	Equalizer is always enabled
		Cleared	Disables the equalizer and sets the equalizer in bypass mode
	Enable Reclocker	Selected*	Reclocker is always enabled
		Cleared	Disables the reclocker and sets the reclocker in bypass mode
	Reclocker Rate	Auto*	Card automatically detects the incoming data rate
		270Mbps	Reclocker is set to 270Mbps
		1.5Gbps	Reclocker is set to 1.5Gbps
		3.0Gbps	Reclocker is set to 3Gbps
	Edit Permission	Unlocked*	All configurable menu options are editable
		Locked	All configurable menu options, except this one, are locked and are read-only
Factory Defaults	Reset	Resets all editable parameters to the factory default values	

- a. This information is only available when the SRA-8802 is installed with a 8320AR-300, or 8320AR-306 full rear module.

Alarms Tab

Table 4.5 summarizes the Alarms options available in DashBoard.

Table 4.5 Alarm Enables Menu Items

Menu Title	Item	Parameters	Description
Channel A	Alarm on Loss of Input	Selected*	The Status field in the Signal tab reports the loss of the input as an error/alarm
		Cleared	The Status field in the Signal tab reports the loss of the input as information only (status indicator does not update)

Specifications

In This Chapter

This chapter includes the technical specifications for the SRA-8802. Note that specifications are subject to change without notice.

The following topics are discussed:

- Technical Specifications

Technical Specifications

This section lists the technical specifications for the SRA-8802.

Table 5.1 Technical Specifications

Category	Parameter		Specification
Rear Modules	Supported Rear Modules		8320AR-300, 8320AR-301, 8320AR-306
SDI Inputs	Number of Inputs	8320AR-300	1 primary, 1 backup
		8320AR-301	1
		8320AR-306	1 primary, 1 backup
	Data Rates and SMPTE Standards Accommodated		19.39Mbps, 38.78Mbps, SMPTE 310 270Mbps, 525/625 Component, SMPTE 259M 270Mbps, DVB-ASI 1.485Gbps Component, SMPTE 292M 2.97Gbps Component, SMPTE 424M
	Impedance		75Ω terminating
	Equalization	8320AR-300, 8320AR-301	>500m (1640ft) of Belden 1694A cable @ 270Mbps >200m (650ft) of Belden 1694A cable @ 1.485Gbps >120m (394ft) of Belden 1694A cable @ 2.97Gbps
		8320AR-306	>500m (1640ft) of Belden 1694A cable @ 270Mbps >200m (650ft) of Belden 1694A cable @ 1.485Gbps >90m (295ft) of Belden 1694A cable @ 2.97Gbps
	Return Loss	8320AR-300, 8320AR-301	>15dB to 3GHz
8320AR-306		>14dB to 1.485GHz >7.8dB to 3GHz	
Connector Type		BNC	
SDI Outputs	Number of Outputs	8320AR-300	8
		8320AR-301	4
		8320AR-306	8
	Impedance		75Ω
	Return Loss		>15dB to 1.485GHz >10dB to 2.97GHz
	Signal Level		800mV ±10%
	DC Offset		0V ±50mV

Table 5.1 Technical Specifications

Category	Parameter	Specification
SDI Outputs	Rise & Fall Time (20-80%)	700ps typical (270Mbps) 120ps typical (1.485Gbps) 135ps typical (2.97Gbps)
	Overshoot	<10%
	Connector Type	BNC
Environment	Maximum Ambient Temperature	40°C (104°F)
Power	Total Power Consumption	2.8W

Service Information

In This Chapter

This chapter contains the following sections:

- Troubleshooting Checklist
- Warranty and Repair Policy

Troubleshooting Checklist

Routine maintenance to this openGear product is not required. In the event of problems with your card, the following basic troubleshooting checklist may help identify the source of the problem. If the frame still does not appear to be working properly after checking all possible causes, please contact your openGear products distributor, or the Technical Support department at the numbers listed under the “**Contact Us**” section at the end of the manual.

1. **Visual Review** — Performing a quick visual check may reveal many problems, such as connectors not properly seated or loose cables. Check the card, the frame, and any associated peripheral equipment for signs of trouble.
2. **Power Check** — Check the power indicator LED on the distribution frame front panel for the presence of power. If the power LED is not illuminated, verify that the power cable is connected to a power source and that power is available at the power main. Confirm that the power supplies are fully seated in their slots. If the power LED is still not illuminated, replace the power supply with one that is verified to work.
3. **Input Signal Status** — Verify that source equipment is operating correctly and that a valid signal is being supplied.
4. **Output Signal Path** — Verify that destination equipment is operating correctly and receiving a valid signal.
5. **Card Exchange** — Exchanging a suspect card with a card that is known to be working correctly is an efficient method for localizing problems to individual cards.

Bootload Button

In the unlikely event of a complete card failure, you may be instructed by a Ross Technical Support specialist to perform a complete software reload on the card.

To perform a complete software reload on the card

1. Eject the card from the openGear frame.
2. Press and hold the **Bootload** button, while re-inserting the card into the frame.
3. Release the button.
 - The **PWR** LED will flash green while the card is waiting for a new software load.
 - If a new software load is not sent to the card within 60 seconds, the card will attempt to restart with its last operational software load.
 - Contact Ross Technical Support for the latest software load for your card.

Warranty and Repair Policy

The SRA-8802 is warranted to be free of any defect with respect to performance, quality, reliability, and workmanship for a period of FIVE (5) years from the date of shipment from our factory. In the event that your SRA-8802 proves to be defective in any way during this warranty period, Ross Video Limited reserves the right to repair or replace this piece of equipment with a unit of equal or superior performance characteristics.

Should you find that this SRA-8802 has failed after your warranty period has expired, we will repair your defective product should suitable replacement components be available. You, the owner, will bear any labor and/or part costs incurred in the repair or refurbishment of said equipment beyond the FIVE (5) year warranty period.

In no event shall Ross Video Limited be liable for direct, indirect, special, incidental, or consequential damages (including loss of profits) incurred by the use of this product. Implied warranties are expressly limited to the duration of this warranty.

This User Manual provides all pertinent information for the safe installation and operation of your openGear Product. Ross Video policy dictates that all repairs to the SRA-8802 are to be conducted only by an authorized Ross Video Limited factory representative. Therefore, any unauthorized attempt to repair this product, by anyone other than an authorized Ross Video Limited factory representative, will automatically void the warranty. Please contact Ross Video Technical Support for more information.

In Case of Problems

Should any problem arise with your SRA-8802, please contact the Ross Video Technical Support Department. (Contact information is supplied at the end of this publication.)

A Return Material Authorization number (RMA) will be issued to you, as well as specific shipping instructions, should you wish our factory to repair your SRA-8802. If required, a temporary replacement frame will be made available at a nominal charge. Any shipping costs incurred will be the responsibility of you, the customer. All products shipped to you from Ross Video Limited will be shipped collect.

The Ross Video Technical Support Department will continue to provide advice on any product manufactured by Ross Video Limited, beyond the warranty period without charge, for the life of the equipment.

Contact Us

Contact our friendly and professional support representatives for the following:

- Name and address of your local dealer
- Product information and pricing
- Technical support
- Upcoming trade show information

Technical Support

Telephone: +1 613 • 652 • 4886
After Hours Emergency: +1 613 • 349 • 0006
Email: techsupport@rossvideo.com

General Information

Telephone: +1 613 • 652 • 4886
Fax: +1 613 • 652 • 4425
Email: solutions@rossvideo.com
Website: <http://www.rossvideo.com>

Visit Us

Visit our website for:

- Company information and news
- Related products and full product lines
- Online catalog
- Testimonials