



openGear

DEA-8805 User Guide

Thank You for Choosing Ross

You've made a great choice. We expect you will be very happy with your purchase of Ross Technology.

Our mission is to:

1. Provide a Superior Customer Experience
 - offer the best product quality and support
2. Make Cool Practical Technology
 - develop great products that customers love

Ross has become well known for the Ross Video Code of Ethics. It guides our interactions and empowers our employees. I hope you enjoy reading it below.

If anything at all with your Ross experience does not live up to your expectations be sure to reach out to us at solutions@rossvideo.com.



David Ross
CEO, Ross Video
dross@rossvideo.com

Ross Video Code of Ethics

Any company is the sum total of the people that make things happen. At Ross, our employees are a special group. Our employees truly care about doing a great job and delivering a high quality customer experience every day. This code of ethics hangs on the wall of all Ross Video locations to guide our behavior:

1. We will always act in our customers' best interest.
2. We will do our best to understand our customers' requirements.
3. We will not ship crap.
4. We will be great to work with.
5. We will do something extra for our customers, as an apology, when something big goes wrong and it's our fault.
6. We will keep our promises.
7. We will treat the competition with respect.
8. We will cooperate with and help other friendly companies.
9. We will go above and beyond in times of crisis. *If there's no one to authorize the required action in times of company or customer crisis - do what you know in your heart is right. (You may rent helicopters if necessary.)*

DEA-8805 · User Guide

- Ross Part Number: **8805DR-004-04**
- Revision: 2
- Release Date: August 21, 2024.

The information contained in this Guide is subject to change without notice or obligation.

Copyright

©2024 Ross Video Limited, Ross®, and any related marks are trademarks or registered trademarks of Ross Video Limited. All other trademarks are the property of their respective companies. PATENTS ISSUED and PENDING. All rights reserved. No part of this publication may be reproduced, stored in a retrieval system, or transmitted in any form or by any means, mechanical, photocopying, recording or otherwise, without the prior written permission of Ross Video. While every precaution has been taken in the preparation of this document, Ross Video assumes no responsibility for errors or omissions. Neither is any liability assumed for damages resulting from the use of the information contained herein.

Patents

Patent numbers US 7,034,886; US 7,508,455; US 7,602,446; US 7,802,802 B2; US 7,834,886; US 7,914,332; US 8,307,284; US 8,407,374 B2; US 8,499,019 B2; US 8,519,949 B2; US 8,743,292 B2; GB 2,419,119 B; GB 2,447,380 B; and other patents pending.

Notice

The material in this manual is furnished for informational use only. It is subject to change without notice and should not be construed as commitment by Ross Video Limited. Ross Video Limited assumes no responsibility or liability for errors or inaccuracies that may appear in this manual.

Safety Notices

Refer to the “**Important Regulatory and Safety Notices**” document that accompanied your product.

Statement of Compliance

This product has been determined to be compliant with the applicable standards, regulations, and directives for the countries where the product is marketed.

Compliance documentation, such as certification or Declaration of Compliance for the product is available upon request by contacting techsupport@rossvideo.com. Please include the product; model number identifiers and serial number and country that compliance information is needed in request.

EMC Notices

US FCC Part 15

This equipment has been tested and found to comply with the limits for a class A Digital device, pursuant to part 15 of the FCC Rules.

These limits are designed to provide reasonable protection against harmful interference when the equipment is operated in a Commercial environment. This equipment generates, uses, and can radiate radio frequency energy and, if not installed and used in accordance with the instruction manual, may cause harmful interference to radio communications. Operation of this equipment in a residential area is likely to cause harmful interference in which case the user will be required to correct the interference at his own expense.



Notice — *Changes or modifications to this equipment not expressly approved by Ross Video Ltd. could void the user's authority to operate this equipment.*

Canada

This Class "A" digital apparatus complies with Canadian ICES-003 and part 15 of the FCC Rules.
Cet appareil numérique de la classe "A" est conforme a la norme NMB-003 du Canada.

European Union

This equipment is in compliance with the essential requirements and other relevant provisions established under regulation (EC) No 765/2008 and Decision No 768/2008/EC referred to as the "New Legislative Framework".



Warning — *This equipment is compliant with Class A of CISPR 32. In a residential environment this equipment may cause radio interference.*

Australia/New Zealand

This equipment is in compliance with the provisions established under the Radiocommunications Act 1992 and Radiocommunications Labeling (Electromagnetic Compatibility) Notice 2008.

Korea

This equipment is in compliance with the provisions established under the Radio Waves Act.

Class A equipment (Broadcasting and communications service for business use)

This device is a business-use (Class A) EMC-compliant device. The seller and user are advised to be aware of this fact. This device is intended for use in areas outside home.

Type of Equipment	User's Guide
A급 기기 (업무용 방송통신기자재)	이 기기는 업무용(A급) 전자파적합기기로서 판매자 또는 사용자는 이 점을 주의하시기 바라며, 가정외의 지역에서 사용하는 것을 목적으로 합니다.
Class A Equipment (Industrial Broadcasting & Communication Equipment)	This equipment is Industrial (Class A) electromagnetic wave suitability equipment and seller or user should take notice of it, and this equipment is to be used in the places except for home.

International

This equipment has been tested under the requirements of CISPR 22:2008 or CISPR 32:2015 and found to comply with the limits for a Class A Digital device.



Notice — *This is a Class A product. In domestic environments, this product may cause radio interference, in which case the user may have to take adequate measures.*

Maintenance/User Serviceable Parts

Routine maintenance to this openGear product is not required. This product contains no user serviceable parts. If the module does not appear to be working properly, please contact Technical Support using the numbers listed under the “**Contact Us**” section of this manual. All openGear products are covered by a generous 5-year warranty and will be repaired without charge for materials or labor within this period. See the “**Warranty and Repair Policy**” section in this manual for details.

Environmental Information

The equipment may contain hazardous substances that could impact health and the environment.

To avoid the potential release of those substances into the environment and to diminish the need for the extraction of natural resources, Ross Video encourages you to use the appropriate take-back systems. These systems will reuse or recycle most of the materials from your end-of-life equipment in an environmentally friendly and health conscious manner.

The crossed-out wheeled bin symbol invites you to use these systems.



If you need more information on the collection, reuse, and recycling systems, please contact your local or regional waste administration. You can also contact Ross Video for more information on the environmental performances of our products.

Company Address



Ross Video Limited

8 John Street
Iroquois, Ontario, K0E 1K0
Canada

Ross Video Incorporated

P.O. Box 880
Ogdensburg, New York
USA 13669-0880

General Business Office: (+1) 613 • 652 • 4886

Fax: (+1) 613 • 652 • 4425

Technical Support: (+1) 613 • 652 • 4886

After Hours Emergency: (+1) 613 • 349 • 0006

E-mail (Technical Support): techsupport@rossvideo.com

E-mail (General Information): solutions@rossvideo.com

Website: <http://www.rossvideo.com>

Contents

Introduction	9
Related Publications	9
Documentation Conventions	9
Interface Elements	9
User Entered Text	9
Referenced Guides	10
Menu Sequences	10
Important Instructions	10
Contacting Technical Support	10
Before You Begin	11
Features	11
Functional Block Diagrams	11
Dual 1x4 Configuration	11
Dual 1x8 Configuration	12
User Interfaces	12
DashBoard Control System	12
Card-edge Monitoring	12
SNMP Monitoring and Control	12
Hardware Overview	15
Card Overview	15
Monitoring Features	15
Status LEDs	16
Physical Installation	17
Before You Begin	17
Static Discharge	17
Unpacking	17
Installing the DEA-8805	17
Supported Rear Modules	17
Installing a Card	17
Cabling	19
Dual 1x4 Configuration	19
Dual 1x8 Configuration	19
Using DashBoard	21
Configuration	23
Configuring the Equalizer for a Channel	23
Loss of Input	23
Upgrading the Software	25
DashBoard Menus	27
Status Tabs	27
Signal Tab	27

Hardware Tab	28
Product Tab	28
Setup Tab	29
Alarms Tab	29
Technical Specifications	31
SDI Inputs Specifications	31
SDI Outputs Specifications	31
Environmental	32
Power	32
Service Information	33
Troubleshooting Checklist	33
Bootload Button	33
Warranty and Repair Policy	33
Glossary	35

Introduction

This guide covers the installation, configuration, and use of the DEA-8805 card. The following chapters are included:

- “**Introduction**” summarizes the guide and provides important terms, and conventions.
- “**Before You Begin**” provides general information to keep in mind before installing and configuring your card.
- “**Hardware Overview**” provides a basic introduction to the hardware features including the cabling and monitoring features of the rear module.
- “**Physical Installation**” provides instructions for the physical installation of the card and its rear module, and provides information on cabling designations.
- “**Cabling**” provides cabling details based on the rear module.
- “**Using Dashboard**” provides a general overview of the user controls available on the DEA-8805.
- “**Configuration**” outlines how to configure the DEA-8805 using the options available in Dashboard.
- “**Upgrading the Software**” provides instructions for upgrading the software for your DEA-8805 using Dashboard.
- “**Dashboard Menus**” summarizes the DEA-8805 menus, items, and parameters in Dashboard.
- “**Technical Specifications**” provides technical specification details on the DEA-8805.
- “**Service Information**” provides information on the warranty and repair policy for your card.
- “**Glossary**” provides a list of terms used throughout this guide.

Related Publications

It is recommended to consult the following Ross documentation before installing and configuring your DEA-8805:

- ***DashBoard User Guide***, Ross Part Number: 8351DR-004
- ***MFC-OG3-N and MFC-8322-S User Guide***, Ross Part Number: 8322DR-004
- ***OG3-FR Series User Guide***, Ross Part Number: 8322DR-005
- ***OGX-FR Series User Guide***, Ross Part Number: 8322DR-204

Documentation Conventions

Special text formats are used in this guide to identify parts of the user interface, text that a user must enter, or a sequence of menus and sub-menus that must be followed to reach a particular command.

Interface Elements

Bold text is used to identify a user interface element such as a dialog box, menu item, or button. For example:

In the **Network** tab, click **Apply**.

User Entered Text

Courier text is used to identify text that a user must enter. For example:

In the **Language** box, enter `English`.

Referenced Guides

Text set in bold and italic represent the titles of referenced guides, manuals, or documents. For example:

For more information, refer to the ***DashBoard User Manual***.

Menu Sequences

Menu arrows are used in procedures to identify a sequence of menu items that you must follow. For example, if a step reads "**File > Save As**," you would click the **File** menu and then click **Save As**.

Important Instructions

Star icons are used to identify important instructions or features. For example:

- ★ Contact your IT department before connecting to your facility network to ensure that there are no conflicts. They will provide you with an appropriate value for the IP Address, Subnet Mask, and Gateway for your device.

Contacting Technical Support

At Ross Video, we take pride in the quality of our products, but if problems occur, help is as close as the nearest telephone.

Our 24-hour Hot Line service ensures you have access to technical expertise around the clock. After-sales service and technical support is provided directly by Ross Video personnel. During business hours (Eastern Time), technical support personnel are available by telephone. After hours and on weekends, a direct emergency technical support phone line is available. If the technical support person who is on call does not answer this line immediately, a voice message can be left and the call will be returned shortly. This team of highly trained staff is available to react to any problem and to do whatever is necessary to ensure customer satisfaction.

- **Technical Support:** (+1) 613-652-4886
- **After Hours Emergency:** (+1) 613-349-0006
- **E-mail:** techsupport@rossvideo.com
- **Website:** <http://www.rossvideo.com>

Before You Begin

Your DEA-8805 is a 3G/HD/SD Multi-Definition SDI distribution amplifier, capable of equalizing all common serial digital signals.

Features

The DEA-8805 includes the following features:

- Equalizes SDI signals of 270Mbps, 1.485Gbp, and 2.97Gbps
- Accepts DVB-ASI (EN 50083-9), and SMPTE 310 signals
- Flexible channel configurations:
 - › Operate as a dual 1x8 (*requires the 8320AR-302 full rear module*)
 - › Operate as a dual 1x4 (*requires the 8320AR-300 full rear module*)
- Configure and monitor via DashBoard
- Automatic detection of incoming data rate
- Automatically mutes the channel output when a loss of input occurs
- LED indicator for signal presence
- Excellent input and output return loss
- Fits DFR-8321, OG3-FR, and OGX-FR series frames
- Fully compliant with openGear specifications
- 5 year transferable warranty

Functional Block Diagrams

The DEA-8805 can operate as an equalizing dual 1x8 or as a dual 1x4. The configuration depends on the rear module you are using. This section provides the block diagrams for all configurations.

Dual 1x4 Configuration

Figure 1 describes the workflow of the DEA-8805 with the 8320AR-300 Full Rear module. This configuration has the DEA-8805 operating as a dual equalizing 1x4 with BNC connections.

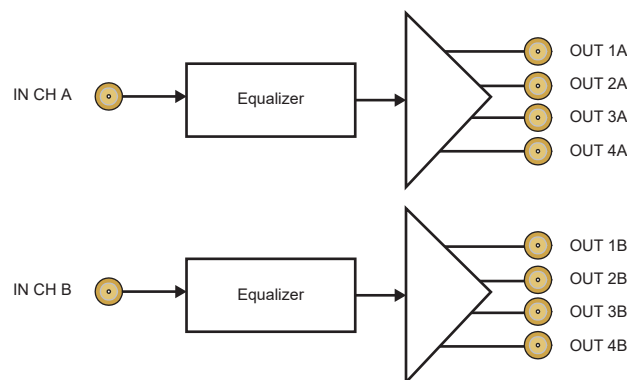

Figure 1 Simplified Diagram — Dual 1x4 Configuration (8320AR-300)

Dual 1x8 Configuration

Figure 2 describes the workflow of the DEA-8805 with the 8320AR-302 Full Rear module. This configuration has the DEA-8805 operating as a dual equalizing 1x8 with HD-BNC connections.

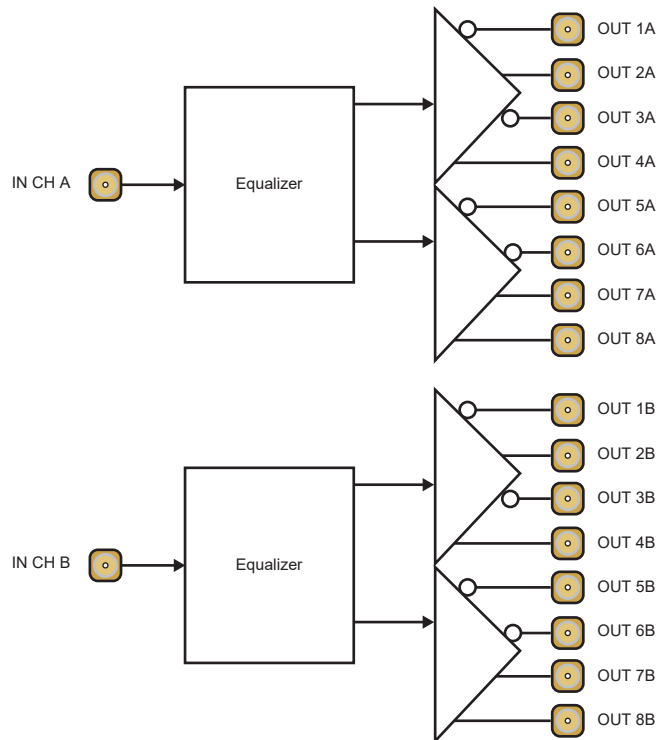

Figure 2 Simplified Diagram — Dual 1x8 Configuration (8320AR-302)

User Interfaces

The following interfaces are available for control and monitoring of your DEA-8805.

DashBoard Control System

DashBoard enables you to monitor and control openGear frames and cards from a computer. DashBoard communicates with other cards in the through the Network Controller Card.

For More Information on...

- menus in DashBoard, refer to **“DashBoard Menus”**.
- installing and using DashBoard, refer to the ***DashBoard User Manual***.

Card-edge Monitoring

The card-edges provide LEDs for monitoring the status of the input signal. Refer to **“Monitoring Features”**.

SNMP Monitoring and Control

The Network Controller Card in the openGear frame provides optional support for remote monitoring and control of your frame and openGear cards using Simple Network Management Protocol (SNMP), which is compatible with many third-party monitoring and control tools.

For More Information on...

- SNMP controls on your card, refer to your DEA-8805 Management Information Base (MIB) file.
- SNMP Monitoring and Control, refer to your ***MFC-8300 Series or MFC-OG3 Series User Manual***.

Hardware Overview

This chapter provides a general overview of the user controls available on your DEA-8805 card.

Card Overview

This section describes the **Bootload** button located on each card surface. There are no other card-edge controls as all configuration and setup is done using the menus in DashBoard. Refer to **Figure 3** for location of this button.

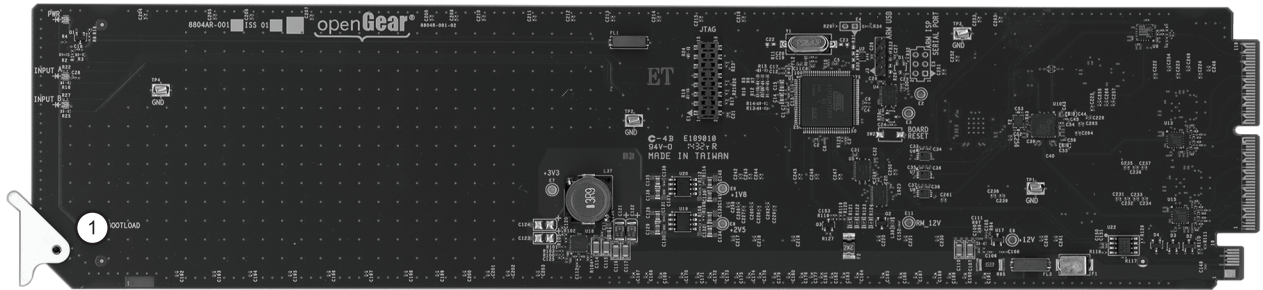

Figure 3 Card-edge Controls

1. Bootload Button

This button is used for factory service in the unlikely event of a complete card failure. Do not use this button unless advised by Ross Technical Support.

For More Information on...

- the Bootload process, refer to **"Bootload Button"**.

Monitoring Features

The following sections describe the card-edge LEDs. Refer to **Figure 4** for LED locations.

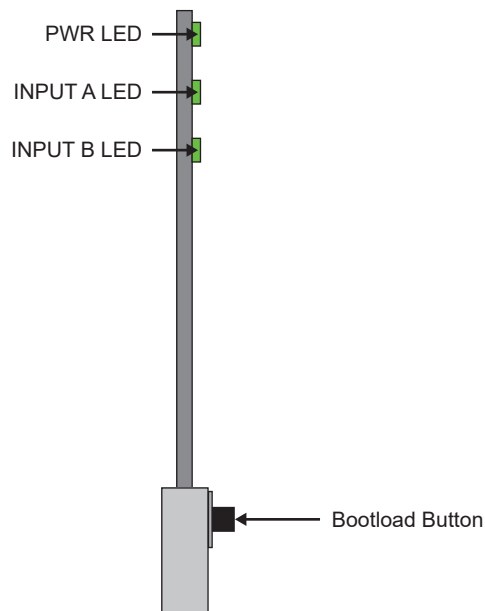

Figure 4 LED Locations

Status LEDs

Table 1 outlines the basic LED behavior.

Table 1 Status LEDs

LED	Color	Display and Description
PWR	Green	When lit green, this LED indicates that the card is functioning normal and that no anomalies have been detected.
	Flashing Green	When flashing green, this LED indicates that the Bootload button was pressed, and the card is receiving a new software load from the frame.
	Flashing Green and Orange	When lit green with flashing orange, this LED indicates a signal or configuration problem. Verify the signal status and settings.
	Amber	When lit amber, this LED indicates the card is running internal diagnostics while powering up.
	Red	When lit red or flashing red, this LED indicates the card is not operational. Re-seat card in frame, check the rear module type and connections, or call Ross Video Technical Support.
	Off	When unlit, this LED indicates there is no power to the card.
INPUT #^a	Green	When lit green, this LED indicates that a valid SDI input signal is present for the specified channel.
	Red	When lit red, this LED indicates that the SDI input signal is missing or invalid for the specified channel.

- a. The INPUT A LED reports on the Channel A source and the INPUT B LED reports on the Channel B source.

Physical Installation

This chapter provides instructions for installing the rear module, and then installing the DEA-8805 card in the openGear frame.

If you have questions pertaining to the installation of your card, contact us at the numbers listed in “**Contacting Technical Support**”. Our technical staff is always available for consultation, training, or service

Before You Begin

Before proceeding with the instructions in this chapter, ensure that your openGear frame is properly installed according to the instructions in its manual.

Static Discharge

Throughout this chapter, please heed the following cautionary note:



ESD Susceptibility — *Static discharge can cause serious damage to sensitive semiconductor devices. Avoid handling circuit boards in high static environments such as carpeted areas and when synthetic fiber clothing is worn. Always exercise proper grounding precautions when working on circuit boards and related equipment.*

Unpacking

Unpack each card you received from the shipping container and ensure that all items are included. If any items are missing or damaged, contact your sales representative or Ross Video directly.

Installing the DEA-8805

The DEA-8805 can be installed in the DFR-8321 series frames, the OG3-FR series, and OGX-FR series frames using one of the supported rear modules. The procedure for installing the rear module and card in your openGear frame is the same regardless of the rear module used.

Supported Rear Modules



Notice — *Ensure that you install the DEA-8805 using one of the supported rear modules listed below. Installing the DEA-8805 with an unsupported rear module can damage the card, the rear module, or both.*

The Rear Module depends on the configuration you wish to use:

- **Dual 1x4 configuration** — The **8320AR-300** full rear module is required.
- **Dual 1x8 configuration** — The **8320AR-302** full rear module is required.

Installing a Card

You must first install the rear module in the frame and then install the card in the appropriate slot within an openGear frame. This section outlines how to perform both tasks.

To install the rear module in the openGear frame

1. Ensure that the frame is properly installed.
2. On the rear of the frame, locate the card frame slot.

3. Remove the Blank Plate from the rear of the slot you have chosen for card installation.
4. As shown below, seat the bottom of the rear module in the seating slot at the base of the frame's back plane.

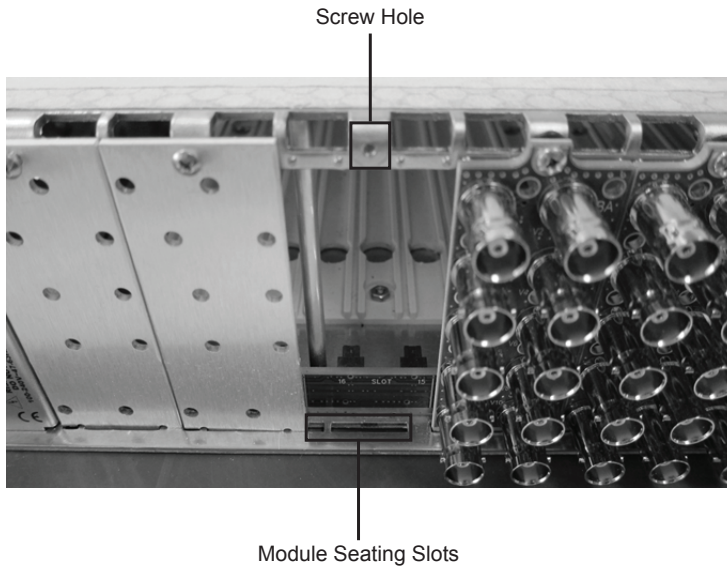

5. Align the top hole of the rear module with the screw hole on the top edge of the frame back plane.
6. Using a Phillips screwdriver and the supplied screw, fasten the rear module to the back plane. Do not over-tighten.
7. Verify whether your rear module label is self-adhesive by checking the back of the label for a thin wax sheet. You must remove the wax sheet before affixing the label.
8. Affix the supplied rear module label to the BNC area of the rear module.
9. Ensure proper frame cooling and ventilation by having all rear frame slots covered with rear modules or blank metal plates.

To install the card in the openGear frame

1. Locate the Rear Module you installed in the procedure **"To install the rear module in the openGear frame"**.
2. Hold the card by the edges and carefully align the card edges with the slots in the frame.
3. Fully insert the card into the frame until the rear connection plugs are properly seated on the midplane and rear modules.

Cabling

The DEA-8805 can operate as a dual 1x8, or as a dual 1x4 depending on the rear module you are using. This chapter provides cabling details based on the configuration.

Dual 1x4 Configuration

The 8320AR-300 full rear module is required when operating in a dual 1x4 configuration. Each rear module occupies two slots and accommodates one card. This rear module provides an SDI input and four SDI outputs per channel (A, B). (Figure 5)

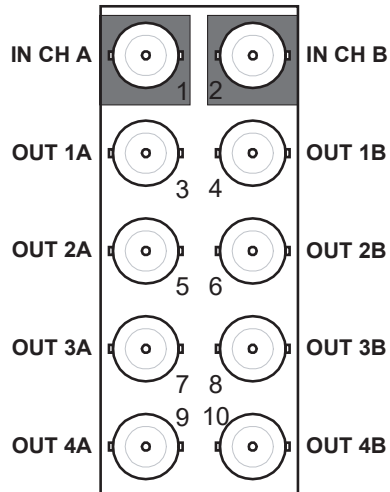
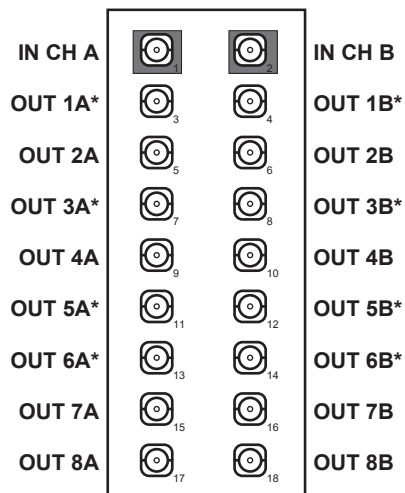

Figure 5 Cable Connections for the 8320AR-300 Full Rear Module

Dual 1x8 Configuration

The 8320AR-302 full rear module is required when operating in a dual 1x8 configuration. Each rear module occupies two slots and accommodates one card. This rear module provides an SDI input and eight SDI outputs per channel (A,B). (Figure 6)



Inverted outputs are noted with an asterisk (*).

Figure 6 Cable Connections for the 8320AR-302 Full Rear Module

Using DashBoard

Before proceeding, ensure that the DashBoard client is installed on a computer connected to your facility network. The DashBoard software and user manual are available from the Ross Video website.

For More Information on...

- installing DashBoard, refer to the ***DashBoard User Manual***.

To launch DashBoard

1. Ensure that you are running DashBoard software version 9.2.0 or higher.
 2. Launch DashBoard by double-clicking its icon on your desktop.
 3. Ensure that the openGear frame with your DEA-8805 card(s) is displayed in the Tree View located on the left-side of the DashBoard window.
- ★ It may take 30 seconds or more to update the Tree View. Consult the ***MFC-8300 Series or MFC-OG3 Series User Manual*** and ***DashBoard User Manual*** should the Tree View not display the card.

To access a card in DashBoard

1. From the **Tree View**, expand the node for the openGear frame your cards are installed in.
A list of cards installed in the frame is now displayed. In the example below, the node for Frame 6 is expanded to show a list of cards including the DEA-8805.
2. Double-click the node for a card to display its menus in the right pane of the DashBoard window.

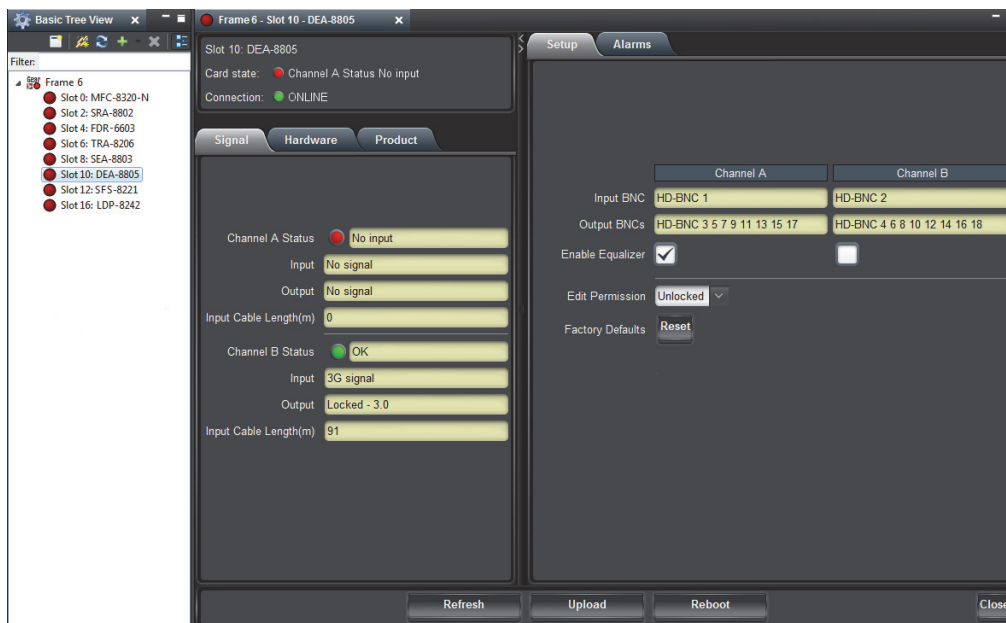

Configuration

This chapter briefly outlines how to configure the DEA-8805 using the options available in DashBoard.

Configuring the Equalizer for a Channel

You can choose to enable or bypass the equalizer on each channel. The equalizer enables the card to compensate for noise and signal losses inherent in long coaxial cable runs. Refer to “**Technical Specifications**” for information on the cable equalization specifications for your card.

★ You must bypass the equalizer when using signals of less than 125Mbps (such as SMPTE 310 signals). For signals 125Mbps and greater (such as SDI signals), you must enable the equalizer.

To enable the equalizer

1. From the **Device View**, select the **Setup** tab.

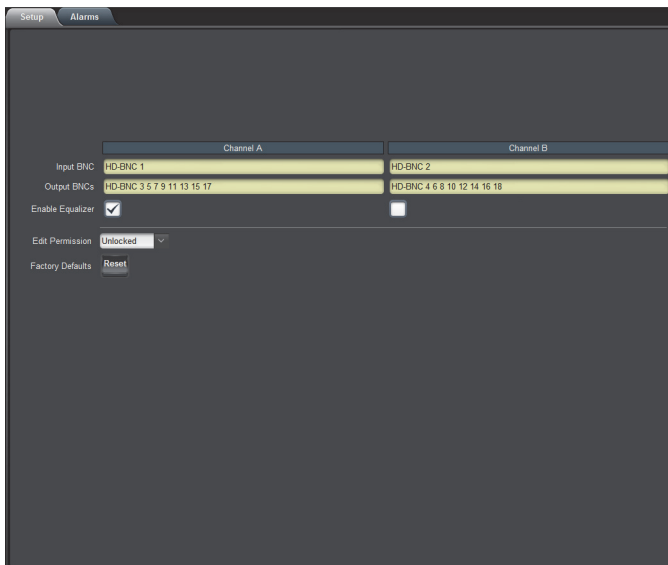

2. Select the **Enable Equalizer** box for the channel. The box displays a check-mark.

To bypass the equalizer

1. From the **Device View**, select the **Setup** tab.
2. Select the **Enable Equalizer** box for the channel to clear the box contents.

Loss of Input

When enabled, this feature will indicate an alarm condition (red) in the **Channel Status** field of the **Signal** tab. This occurs if the DEA-8805 does not detect a valid input signal for that channel. To verify which BNC to troubleshoot, refer to the rear module labeling or the **Input BNC** field in the **Setup** tab.

To enable an alarm for a loss of input

1. From the **Device View**, select the **Alarms** tab.
2. Select the **Alarm on Loss of Input** box for the channel.

Upgrading the Software

The DEA-8805 can be upgraded in the field via DashBoard.

To upgrade the software on a card

1. Contact Ross Technical Support for the latest software version file.
 2. Ensure the Ethernet cable is connected to the **Ethernet** port on the openGear frame.
 3. From the **Tree View**, expand the node for the DEA-8805 you want to access.
 4. Double-click the **Global** sub-node to display the interface in the right-half of DashBoard.
 5. Select **Upload**, located near the bottom of the interface, to display the **Select file Upload** dialog.
 6. Navigate to the ***.bin** file you want to upload.
 7. Click **Open**.
 8. If you are upgrading a single card:
 - a. Click **Finish** to start the upgrade.
 - b. Proceed to step step 10..
 9. If you are upgrading multiple cards:
 - a. Click **Next >** to display the **Select Destination** menu. This menu provides a list of the compatible cards.
 - b. Specify the card(s) to upload the file to by selecting the check box(es) for the cards you want to upload the file to.
 - c. Verify the card(s) you want to upload the file to. The **Error/Warning** fields indicate any errors, such as incompatible software or card type mismatch.
 - d. Click **Finish**.
 10. Monitor the upgrade.
 - An **Upload Status** dialog enables you to monitor the upgrade process.
 - Notice that each card is listed in the dialog with a  button. This button is replaced with a **Reboot** button once the software file is loaded to that card.
- ★ Avoid clicking the individual Reboot buttons until all cards have successfully completed the file upload process and the OK button, located in the bottom right corner of the dialog, is enabled.
- Click **OK** to reboot all the cards listed in the **Uploading to Selected Devices** dialog.
 - The **Reboot Confirm** dialog displays, indicating the number of cards that will reboot. Click **Yes** to continue the upgrade process. Note that clicking **Cancel** or **No** returns you to the **Uploading to Selected Devices** dialog without rebooting the card(s).
 - The card(s) are temporarily taken off-line during the reboot process. The process is complete once the status indicators for the **Card State** and **Connection** return to their previous status.

DashBoard Menus

This chapter briefly summarizes the menus, items, and parameters available from DashBoard for your card. Default parameters are noted with an asterisk (*).

- ★ Wait 30 seconds after the last setting change to ensure all changes are saved to the non-volatile memory of the card.

Status Tabs

This section summarizes the read-only information displayed in the **Status** tabs. The fields in the **Signal** tab vary in severity from green (valid), yellow (caution), to red (alarm). DashBoard reports the most severe alarm for a single field. Alarm colors are noted within the tables as text set in brackets next to the menu parameter name.

Signal Tab

Table 2 outlines the read-only information displayed in the **Signal** tab.

Table 2 Signal Tab Items

Item	Parameters	Description
Channel #		
Status	OK (Green)	A valid input signal is detected
	No input (Red)	Input signal is not present. The Alarm on Loss of Input for this channel is enabled.
	No input (Green)	Input signal is not present. The Alarm on Loss of Input for this channel is disabled.
Input	No signal	Input signal is not present
	<125mB/s signal	A signal detected at less than 125Mbps is present
	SD signal	A valid 270Mbps input signal is present
	HD signal	A valid 1.485Gbps input signal is present
	3G signal	A valid 2.97Gbps input signal is present
	Equalizer bypassed	Input signal is present and the equalizer is bypassed (the Enable Equalizer check box is not selected in the Setup tab)
Output	Signal present	Input signal is present and valid
	No signal (muted)	Input signal is not present
Input Cable Length (m)	x (1694A) / y (1855A)	Indicates the approximate cable length used for the input signal where: <ul style="list-style-type: none">• x represents the Belden 1694A length• y represents the Belden 1855A length

Table 2 Signal Tab Items

Item	Parameters	Description
Input Cable Length (m)	N/A	One of the following is occurring: <ul style="list-style-type: none"> a valid input source was not detected on the input BNC the Enable Equalizer check box is not selected in the Setup tab

Hardware Tab

Table 3 outlines the read-only information displayed in the **Hardware** tab.

Table 3 Hardware Tab Items

Item	Parameters	Description
HW Status	OK (Green)	The rear module installed with the card is supported and the card is operating correctly
	Incomp Rear Module (Red)	One of the following is occurring: <ul style="list-style-type: none"> an unsupported rear module is installed with the card the card is installed in the wrong frame slot (where the card does not align with the connector on the rear module)
Voltage (mV)	#	Supply voltage
Current (mA)	#	Current consumption of card in milliamperes
CPU Headroom	#	Processing power available
RAM Available	#	On-board processing memory available
Uptime (h)	#	Displays the number of hours since the last reboot of the card
Configuration Bank	#	Storage count

Product Tab

Table 4 outlines the read-only information displayed in the **Product** tab.

Table 4 Product Tab Items

Item	Parameters	Description
Product	DEA-8805	Displays the card model
Supplier	Ross Video Ltd.	Indicates the manufacturer of your card
Board Rev	##	Indicates the version of the PCB
Board S/N	#####	Indicates the card serial number
Rear Module	#	Indicates the installed rear module
	Unknown	Indicates that the installed rear module is not recognized by the card
Software Rev	##.##	Indicates the software version

Setup Tab

Table 5 summarizes the **Setup** options available in DashBoard.

Table 5 Setup Menu Items

Item	Parameters	Description
Channel #		
Input BNC	# (read-only)	Indicates the BNC on the rear module that is assigned as the input source for the specified channel
	N/C	Indicates that no BNCs are currently used as inputs for the channel
Output BNCs	# (read-only)	Indicates the BNCs on the rear module that are assigned as the outputs for the specified channel
	N/C	Indicates that there are no outputs in this channel
Enable Equalizer	Selected*	Equalizer is always enabled
	Cleared	Disables the equalizer and sets the equalizer in bypass mode
Edit Permission	Unlocked*	All configurable menu options are editable
	Locked	All configurable menu options, except this one, are locked and are read-only
Factory Defaults	Reset	Resets all editable parameters to the factory default values

Alarms Tab

Table 6 summarizes the **Alarms** options available in DashBoard.

Table 6 Alarm Enables Menu Items

Item	Parameters	Description
Channel #		
Alarm on Loss of Input	Selected*	The Status fields in the Signal tab reports the loss of the specified input as an error/alarm
	Cleared	The Status fields in the Signal tab reports the loss of the specified input as information only (status indicator does not update)

Technical Specifications

This chapter includes the technical specifications for the DEA-8805.

★ Specifications are subject to change without notice.

SDI Inputs Specifications

Table 7 Technical Specifications — SDI Inputs

Parameter		Specification
Number of Inputs		2
Data Rates and SMPTE Standards Accommodated		19.39Mbps, 38.78Mbps, SMPTE 310 270Mbps, 525/625 Component, SMPTE 259M 270Mbps, DVB-ASI 1.485Gbps Component, SMPTE 292M 2.97Gbps Component, SMPTE 424M
Impedance		75Ω terminating
Equalization		>500m (1640ft) of Belden 1694A cable @ 270MBps >200m (650ft) of Belden 1694A cable @ 1.485GBps >120m (394ft) of Belden 1694A cable @ 2.97GBps
Return Loss		>15dB to 3GHz
Connector Type	8320AR-300	BNC
	8320AR-302	HD-BNC

SDI Outputs Specifications

Table 8 Technical Specifications — SDI Outputs

Parameter		Specification
Number of Outputs	8320AR-300	4 per channel
	8320AR-302	8 per channel
Impedance		75Ω
Return Loss		>15dB to 1.485GHz >10dB to 2.97GHz
Signal Level		800mV ±10%
DC Offset		0V ±50mV
Rise & Fall Time (20-80%)		700ps typical (270Mbps) 120ps typical (1.485Gbps) 135ps typical (2.97Gbps)
Overshoot		<10%
Connector Type	8320AR-300	BNC
	8320AR-302	HD-BNC

Environmental

Table 9 Technical Specifications — Environmental

Parameter	Specification
Maximum Ambient Temperature	40°C (104°F)

Power

Table 10 Technical Specifications — Power

Parameter	Specification
Total Power Consumption	3.0W

Service Information

This chapter provides information on the warranty and repair policy for your DEA-8805.

Troubleshooting Checklist

Routine maintenance to this openGear product is not required. In the event of problems with your card, the following basic troubleshooting checklist may help identify the source of the problem. If the frame still does not appear to be working properly after checking all possible causes, please contact your openGear products distributor, or the Technical Support department at the numbers listed in “**Contacting Technical Support**”.

1. **Visual Review** — Performing a quick visual check may reveal many problems, such as connectors not properly seated or loose cables. Check the card, the frame, and any associated peripheral equipment for signs of trouble.
2. **Power Check** — Verify the power indicator LED on the distribution frame front panel for the presence of power. If the power LED is not illuminated, verify that the power cable is connected to a power source and that power is available at the power main. Confirm that the power supplies are fully seated in their slots. If the power LED is still not illuminated, replace the power supply with one that is verified to work.
3. **Input Signal Status** — Verify that source equipment is operating correctly and that a valid signal is being supplied.
4. **Output Signal Path** — Verify that destination equipment is operating correctly and receiving a valid signal.
5. **Card Exchange** — Exchanging a suspect card with a card that is known to be working correctly is an efficient method for localizing problems to individual cards.

Bootload Button

In the unlikely event of a complete card failure, you may be instructed by a Ross Technical Support specialist to perform a complete software reload on the card.

To perform a complete software reload on the card

1. Eject the card from the openGear frame.
2. Press and hold the **Bootload** button, while re-inserting the card into the frame.
3. Release the button.
 - The **PWR** LED will flash green while the card is waiting for a new software load.
 - If a new software load is not sent to the card within 60 seconds, the card will attempt to restart with its last operational software load.
 - Contact Ross Technical Support for the latest software load for your card.

Warranty and Repair Policy

The DEA-8805 is warranted to be free of any defect with respect to performance, quality, reliability, and workmanship for a period of FIVE (5) years from the date of shipment from our factory. In the event that your DEA-8805 proves to be defective in any way during this warranty period, Ross Video Limited reserves the right to repair or replace this piece of equipment with a unit of equal or superior performance characteristics.

Should you find that this DEA-8805 has failed after your warranty period has expired, we will repair your defective product should suitable replacement components be available. You, the owner, will

bear any labor and/or part costs incurred in the repair or refurbishment of said equipment beyond the FIVE (5) year warranty period.

In no event shall Ross Video Limited be liable for direct, indirect, special, incidental, or consequential damages (including loss of profits) incurred by the use of this product. Implied warranties are expressly limited to the duration of this warranty.

This User Manual provides all pertinent information for the safe installation and operation of your openGear Product. Ross Video policy dictates that all repairs to the DEA-8805 are to be conducted only by an authorized Ross Video Limited factory representative. Therefore, any unauthorized attempt to repair this product, by anyone other than an authorized Ross Video Limited factory representative, will automatically void the warranty. Please contact Ross Video Technical Support for more information.

In Case of Problems

Should any problem arise with your DEA-8805, please contact the Ross Video Technical Support Department. (Contact information is supplied at the end of this publication.)

A Return Material Authorization number (RMA) will be issued to you, as well as specific shipping instructions, should you wish our factory to repair your DEA-8805. If required, a temporary replacement frame will be made available at a nominal charge. Any shipping costs incurred will be the responsibility of you, the customer. All products shipped to you from Ross Video Limited will be shipped collect.

The Ross Video Technical Support Department will continue to provide advice on any product manufactured by Ross Video Limited, beyond the warranty period without charge, for the life of the equipment.

Glossary

The following terms are used throughout this guide:

Active image — the portion of the video picture area (production aperture) that is being utilized for output content. Active image excludes letterbox bars and pillar-box bars.

Card — refers to all DEA-8805 models unless otherwise noted.

DashBoard — the DashBoard Control System.

DTVCC captions — CEA-708 captions.

Frame — the openGear frame that houses the DEA-8805 unless otherwise noted.

MIB — management information base.

Network Controller Card — the MFC-OG3-N and any available options unless otherwise noted.

NTSC captions — the CEA-608-D: Line 21 Data Services captions.

openGear Frame — refers to the OG3-FR series and OGX-FR series frames unless otherwise noted.

PAL — PAL-B and PAL-G unless otherwise noted.

Production aperture — the image lattice that represents the maximum possible image extent in a given standard (e.g. the full size of all active pixels and active lines). For example, the 1080i production aperture would be 1920x1080.

System — the mix of interconnected production and terminal equipment in your environment.

UDP — User Datagram Protocol.

User — the person who uses the DEA-8805.

