

SRG-4400

Master Reference and Test Signal Generator User Manual



Thank you for choosing Ross

You've made a great choice. We expect you will be very happy with your purchase of Ross Technology.

Our mission is to:

1. Provide a Superior Customer Experience
 - offer the best product quality and support
2. Make Cool Practical Technology
 - develop great products that customers love

Ross has become well known for the Ross Video Code of Ethics. It guides our interactions and empowers our employees. I hope you enjoy reading it below.

If anything at all with your Ross experience does not live up to your expectations be sure to reach out to us at solutions@rossvideo.com.



David Ross
CEO, Ross Video
dross@rossvideo.com

Ross Video Code of Ethics

Any company is the sum total of the people that make things happen. At Ross, our employees are a special group. Our employees truly care about doing a great job and delivering a high quality customer experience every day. This code of ethics hangs on the wall of all Ross Video locations to guide our behavior:

1. We will always act in our customers' best interest.
2. We will do our best to understand our customers' requirements.
3. We will not ship crap.
4. We will be great to work with.
5. We will do something extra for our customers, as an apology, when something big goes wrong and it's our fault.
6. We will keep our promises.
7. We will treat the competition with respect.
8. We will cooperate with and help other friendly companies.
9. We will go above and beyond in times of crisis. *If there's no one to authorize the required action in times of company or customer crisis - do what you know in your heart is right. (You may rent helicopters if necessary.)*

SRG-4400 User Manual

- Ross Part Number: 4400DR-004A-06
- Release Date: July 6, 2017.

Copyright

© 2017 Ross Video Limited. Ross®, openGear®, and any related marks are trademarks or registered trademarks of Ross Video Ltd. All other trademarks are the property of their respective companies. PATENTS ISSUED and PENDING. All rights reserved. No part of this publication may be reproduced, stored in a retrieval system, or transmitted in any form or by any means, mechanical, photocopying, recording or otherwise, without the prior written permission of Ross Video. While every precaution has been taken in the preparation of this document, Ross Video assumes no responsibility for errors or omissions. Neither is any liability assumed for damages resulting from the use of the information contained herein.

Patents

Patent numbers US 7,034,886; US 7,508,455; US 7,602,446; US 7,802,802 B2; US 7,834,886; US 7,914,332; US 8,307,284; US 8,407,374 B2; US 8,499,019 B2; US 8,519,949 B2; US 8,743,292 B2; GB 2,419,119 B; GB 2,447,380 B; and other patents pending.

Important Regulatory and Safety Notices to Service Personnel

Before using this product and any associated equipment, refer to the “**Important Safety Instructions**” listed below to avoid personnel injury and to prevent product damage.

Product may require specific equipment, and/or installation procedures to be carried out to satisfy certain regulatory compliance requirements. Notices have been included in this publication to call attention to these specific requirements.

Symbol Meanings



This symbol on the equipment refers you to important operating and maintenance (servicing) instructions within the Product Manual Documentation. Failure to heed this information may present a major risk of damage to persons or equipment.



Warning — *The symbol with the word “Warning” within the equipment manual indicates a potentially hazardous situation, which, if not avoided, could result in death or serious injury.*



Caution — *The symbol with the word “Caution” within the equipment manual indicates a potentially hazardous situation, which, if not avoided, may result in minor or moderate injury. It may also be used to alert against unsafe practices.*



Notice — *The symbol with the word “Notice” within the equipment manual indicates a potentially hazardous situation, which, if not avoided, may result in major or minor equipment damage or a situation which could place the equipment in a non-compliant operating state.*



ESD Susceptibility — *This symbol is used to alert the user that an electrical or electronic device or assembly is susceptible to damage from an ESD event.*

Important Safety Instructions



Warning — *Certain parts of this equipment namely the power supply area still present a safety hazard, with the power switch in the OFF position. To avoid electrical shock, disconnect all A/C power cords from the chassis’ rear appliance connectors before servicing this area.*



Warning — *Service barriers within this product are intended to protect the operator and service personnel from hazardous voltages. For continued safety, replace all barriers after any servicing.*

This product contains safety critical parts, which if incorrectly replaced may present a risk of fire or electrical shock. Components contained with the product’s power supplies and power supply area, are not intended to be customer serviced and should be returned to the factory for repair. To reduce the risk of fire, replacements fuses must be the same time and rating. Only use attachments/accessories specified by the manufacturer.

EMC Notices

United States of America FCC Part 15

This equipment has been tested and found to comply with the limits for a class A Digital device, pursuant to part 15 of the FCC Rules. These limits are designed to provide reasonable protection against harmful interference when the equipment is operated in a commercial environment. This equipment generates, uses, and can radiate radio frequency energy and, if not installed and used in accordance with the instruction manual, may cause harmful interference to radio communications. Operation of this equipment in a residential area is likely to cause harmful interference in which case the user will be required to correct the interference at their own expense.



Notice — *Changes or modifications to this equipment not expressly approved by Ross Video Limited could void the user's authority to operate this equipment.*

CANADA

This Class “A” digital apparatus complies with Canadian ICES-003.

Cet appareil numérique de la classe “A” est conforme à la norme NMB-003 du Canada.

EUROPE

This equipment is in compliance with the essential requirements and other relevant provisions of CE Directive 93/68/EEC.

INTERNATIONAL

This equipment has been tested to **CISPR 22:2009** and found to comply with the limits for a Class A Digital device.



Notice — *This is a Class A product. In domestic environments, this product may cause radio interference, in which case the user may have to take adequate measures.*

Maintenance/User Serviceable Parts

Routine maintenance to this Ross Video product is not required. This product contains no user serviceable parts. If the module does not appear to be working properly, please contact Technical Support using the numbers listed under the “Contact Us” section on the last page of this manual. This Ross Video product is covered by a generous 3-year warranty and will be repaired without charge for materials or labor within this period. See the “Warranty and Repair Policy” section in this manual for details.

Environmental Information

The equipment that you purchased required the extraction and use of natural resources for its production. It may contain hazardous substances that could impact health and the environment.

To avoid the potential release of those substances into the environment and to diminish the need for the extraction of natural resources, Ross Video encourages you to use the appropriate take-back systems. These systems will reuse or recycle most of the materials from your end-of-life equipment in an environmentally friendly and health conscious manner.

The crossed out wheelie bin symbol invites you to use these systems.



If you need more information on the collection, re-use, and recycling systems, please contact your local or regional waste administration.

You can also contact Ross Video for more information on the environmental performance of our products.

This product is classified under Category 3, IT and Telecommunications Equipment, and is therefore inside and complies with the scope of the (2011/65/EU) RoHS Directive.

Company Address



Ross Video Limited

8 John Street
Iroquois, Ontario, K0E 1K0
Canada

Ross Video Incorporated

P.O. Box 880
Ogdensburg, New York
USA 13669-0880

General Business Office: (+1) 613 • 652 • 4886

Fax: (+1) 613 • 652 • 4425

Technical Support: (+1) 613 • 652 • 4886

After Hours Emergency: (+1) 613 • 349 • 0006

E-mail (Technical Support): techsupport@rossvideo.com

E-mail (General Information): solutions@rossvideo.com

Website: <http://www.rossvideo.com>

Contents

- Introduction** **1**
 - Overview..... 1-2
 - Features..... 1-2
 - Functional Block Diagrams 1-3
 - Inputs, and Audio Generator 1-3
 - SDI Outputs 1-3
 - Composite Pattern and Tri-Sync/Composite Black Outputs 1-4
 - Timecode 1-4
 - Signal Processing Modules 1-5
 - Documentation Terms and Conventions..... 1-6

- Physical Installation** **2**
 - Before You Begin 2-2
 - Static Discharge 2-2
 - Unpacking..... 2-2
 - Initial Product Inspection 2-3
 - Operating Environment Requirements 2-4
 - Rack Mount Installation..... 2-5
 - Installing the SRG-4400 into a Rack Unit..... 2-5
 - Installing the Rear Support Brackets 2-5
 - Installing the Breakout PCB 2-6
 - Before You Begin..... 2-6
 - Installing the Breakout PCB on the Rack Tray 2-7
 - Installing the Breakout PCB into the Rack Frame 2-7
 - Connecting the Breakout PCB to the SRG-4400 2-8
 - Cabling the Connectors on the Breakout PCB 2-9
 - Connecting Power..... 2-10
 - Replacing a Power Supply..... 2-10
 - Accessories and Options..... 2-12
 - Standard Accessories..... 2-12
 - Additional Software Options..... 2-12

- Functional Check Procedures** **3**
 - Required Equipment 3-2
 - Before You Begin 3-3
 - Initial Power-Up 3-4
 - Initial Configuration 3-5
 - Check Outputs..... 3-6
 - Composite (Analog) Video Signal Outputs: 3-6
 - Black 1 (Analog) Video Signal Outputs 3-6
 - Tri-Black 2 / 3 / 4 Tri-Level Sync Outputs 3-7
 - Serial Digital Video Signal Outputs 3-7
 - SDI Embedded Audio Settings..... 3-8
 - AES / EBU Audio Outputs..... 3-8
 - Analog Audio Outputs..... 3-9

Time and Timecode Settings	3-10
Genlock Mode	3-11
System Functions.....	3-11
Network Settings	3-12
Option Enable Settings	3-12
Calibration Settings	3-13
Operational Configuration	3-14

Operating Basics **4**

Front Panel Overview	4-2
Rear Panel Overview.....	4-4
Operating Basics	4-6
Software Upgrades	4-7
Before You Begin	4-7
Uploading the Software Files	4-7

Menu System **5**

Menu Screens and Maps	5-2
Audio Menus.....	5-5
Video Menus	5-9
Menu Descriptions.....	5-10
Timecode Menus	5-21
Menu Examples	5-23
Menu Descriptions.....	5-24
Additional Information for the Summer/Winter DST.....	5-30
Additional Information for the Leap Second Event (UTC).....	5-32
Genlock Menus	5-34
Menu Descriptions.....	5-35
System Setup Menus	5-39
Temperature Reports	5-39
Event Report	5-40
System Report.....	5-41
GPS Report	5-43
Configuration Menu	5-45
Network Menu	5-48
Other Menus	5-49
NTP Menus	5-50
NTP System is Off.....	5-50
NTP Client Mode.....	5-50
Server Mode.....	5-51
DashBoard Menu	5-53
Backup Device Menu	5-55
Poll the Primary SPG on.....	5-55
IP Address, SubNet Mask.....	5-55
Poll is disabled.....	5-55
This is PRIMARY, so never poll.....	5-55
Option Enable Menu	5-57
Calibration Menu	5-59
Disclaimer.....	5-60

Troubleshooting **6**

Troubleshooting Checklist	6-2
Equipment Checklist	6-3
Contacting Ross Video Technical Support	6-4

Specifications	7
General Characteristics	7-2
Performance Conditions	7-2
Reference Specifications.....	7-3
Video Reference Inputs	7-3
Frequency Reference Inputs	7-3
GPS Receiver Antenna Input	7-4
Frequency Reference Outputs	7-4
1Hz Frequency Reference Output	7-4
Analog Video Outputs	7-5
Notes on Field Blanking.....	7-5
Serial Digital Interface.....	7-7
Audio Specifications.....	7-9
AES/EBU Audio Unbalanced Outputs.....	7-9
AES/EBU Audio Balanced Outputs.....	7-9
Analog Audio Outputs.....	7-10
LTC Outputs	7-11
Programmable Pulse Unbalanced Outputs	7-12
Communication Interfaces	7-13
General Purpose Interface (GPI)	7-13
RS-232 Interface.....	7-13
Ethernet Interface.....	7-14
AC Power Source.....	7-15
Physical Specifications	7-16
Clearance	7-16
Mechanical Characteristics.....	7-16
Environment Characteristics	7-16
 Certifications and Compliances	 8
Certifications and Compliances	8-2
 Connector Pinouts	 9
Balanced Audio/AES/LTC Connector.....	9-2
Pin Views of Connectors	9-3
GPI/RS232 Connector	9-4
Connector Pinouts	9-4
Breakout Cable	9-4
Pin Views of Chassis Connectors.....	9-5
 Characters for Idents	 10
Notes about Compatibility Characters	10-2
Characters Available.....	10-3
 Test Patterns	 11
525i Test Patterns.....	11-2
625i Test Patterns.....	11-4
720p Test Patterns.....	11-6
1035i Test Patterns.....	11-8
1080i and 1080PsF Test Patterns.....	11-10
1080p Test Patterns.....	11-12
 Connecting via DashBoard	 12
General Usage.....	12-2

Accessing the SRG-4400 via DashBoard	12-3
NTP Option	13
Overview	13-2
Background Information	13-3
Simplified NTP Flowcharts.....	13-4
Required Time Corrections.....	13-6
GPS Option	14
Before You Begin	14-2
System Requirements.....	14-3
Cable, Antenna, and Amplifier Combinations	14-3
Installing the GPS Antenna.....	14-4
Connecting the SRG-4400 to the GPS Antenna	14-6
Connection without a Line Amplifier.....	14-6
Connection with a Line Amplifier.....	14-7
Operation.....	14-8
Locking the SRG-4400 to GPS.....	14-8
Signal Requirements.....	14-9
Required Time Corrections.....	14-9
System Noise Floor.....	14-9
Simplified GPS Flowchart.....	14-10
Date in the User Bits of Timecode	15
Service Information	16
User Maintenance.....	16-2
General Care	16-2
Exterior Cleaning.....	16-2
Preventive Maintenance.....	16-2
Servicing	16-3
Service Safety Overview	16-3
Important Information Regarding the use of Switch Cleaners	16-3
Warranty and Repair Policy	16-4

Introduction

In This Chapter

This chapter contains the following sections:

- Overview
- Functional Block Diagrams
- Documentation Terms and Conventions

A Word of Thanks

Congratulations on choosing the SRG-4400 Master Reference and Test Signal Generator. Thank you for joining the group of worldwide satisfied Ross Video customers!

Should you have a question pertaining to the installation or operation of your SRG-4400, please contact us at the numbers listed on the back cover of this manual. Our technical support staff is always available for consultation, training, or service.

Overview

The SRG-4400 is designed for high stability Master Sync operation. The product can provide a wide range of accurate reference signals including analog composite video, analog composite black-burst, tri-level sync, SD, HD and 3G serial digital (SDI) video, and SD, HD, and 3G SDI black. Additionally, there are AES/EBU digital audio outputs, an external frequency reference input, and a GPS input.

The SRG-4400, in its base configuration, is supplied as a Composite SPG with multiple Color Black and SD-SDI outputs. The Color Black outputs are configured to be capable of providing tri-level syncs. A sub-module also provides an interface for additional signals including AES/EBU digital audio outputs, analog audio outputs, LTC outputs, a GPS input, and an external frequency reference input.

Additional options above the base configuration are enabled using special Option Keys. These options are: GPS (SRG-4400-GPS) and NTP (SRG-4400-NTP). The connectors and associated hardware for these options will already be present, the Option Keys simply enable the GPS or NTP option.

The SRG-4400 comes standard with a dual power supply unit (PSU) configuration which has two PSU installed into the front of the unit, and can be “hot-swapped” should problems be encountered.

A companion automatic changeover unit, the ACO-4400A, is also available.

Features

The SRG-4400 includes the following:

- High Stability Internal Reference
- Genlock to the NTSC/PAL Black-Burst signals or optionally to GPS
- Frequency Lock to 10 MHz
- 2 Composite Analog Video signal outputs + 2 Composite Analog Black-Burst signal outputs
- 2 Independent Serial Digital Video signal outputs + 2 SDI Black outputs
- 3 Independent Pattern Generators
- 3 Independent Monochrome ID text and Monochrome Logo Generators supporting international characters
- 3 Independent and Timeable Black-Burst or Tri-Sync Generators
- 11 Independent channels of Timecode: 4 Longitudinal Timecode (LTC) outputs (Balanced), 2 Serial Digital VITC / ATC, and 5 Analog Video VITC
- 82 channels of Audio: 16 channels of Embedded Audio in each of 4 SDI outputs, 16 channels of Audio in 8 AES/EBU Serial Digital Audio outputs (8 Balanced and 2 BNC), 1 Stereo Analog Audio output (Balanced)
- 2 AES/EBU DARS Serial Digital Audio outputs (1 Balanced and 1 BNC)
- 48 kHz and 44.1 kHz Word Clock output
- 1Hz, 6Hz and 10MHz Reference output
- GPI (General Purpose Interface) for error status report and user preset
- Ethernet (100 BASE-T) Interface for connection to the DashBoard Control System
- No fans
- N+1 power redundancy
- Tight integration with the ACO-4400A Channel Changeover unit

Functional Block Diagrams

This section provides the functional block diagrams that outline the workflow of the SRG-4400.

Inputs, and Audio Generator

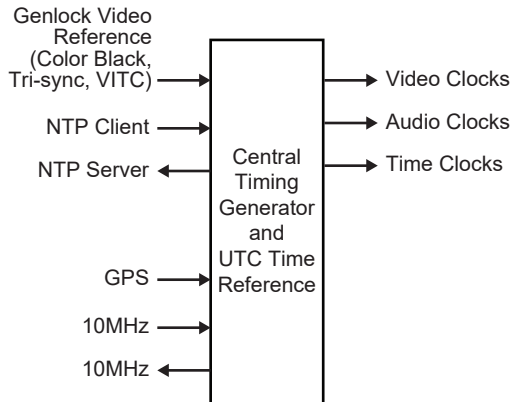

Figure 1.1 Central Timing Generator

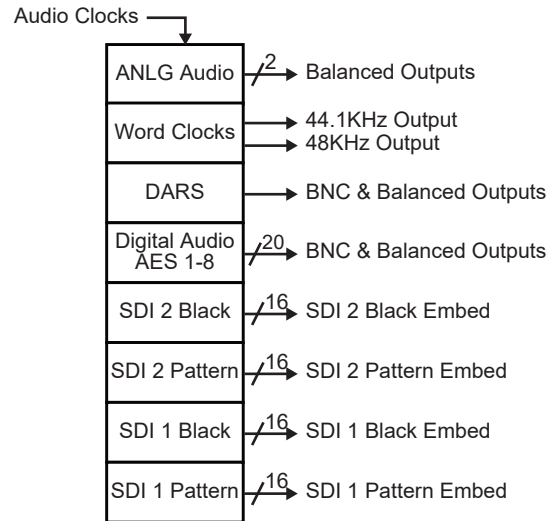

Figure 1.2 Audio Generator

SDI Outputs

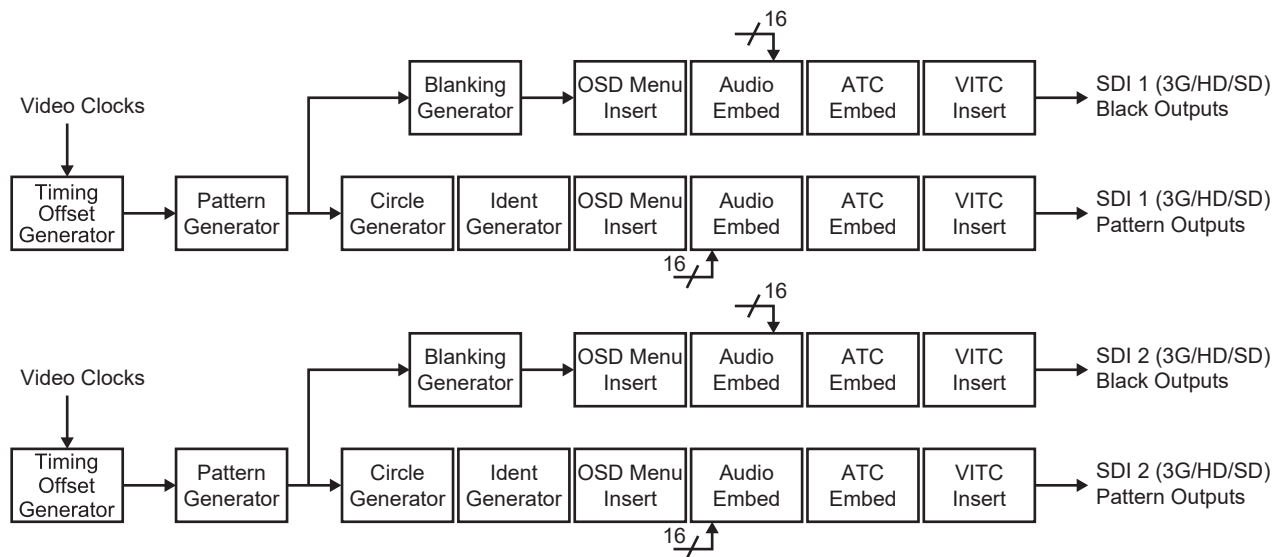

Figure 1.3 SDI Outputs

Composite Pattern and Tri-Sync/Composite Black Outputs

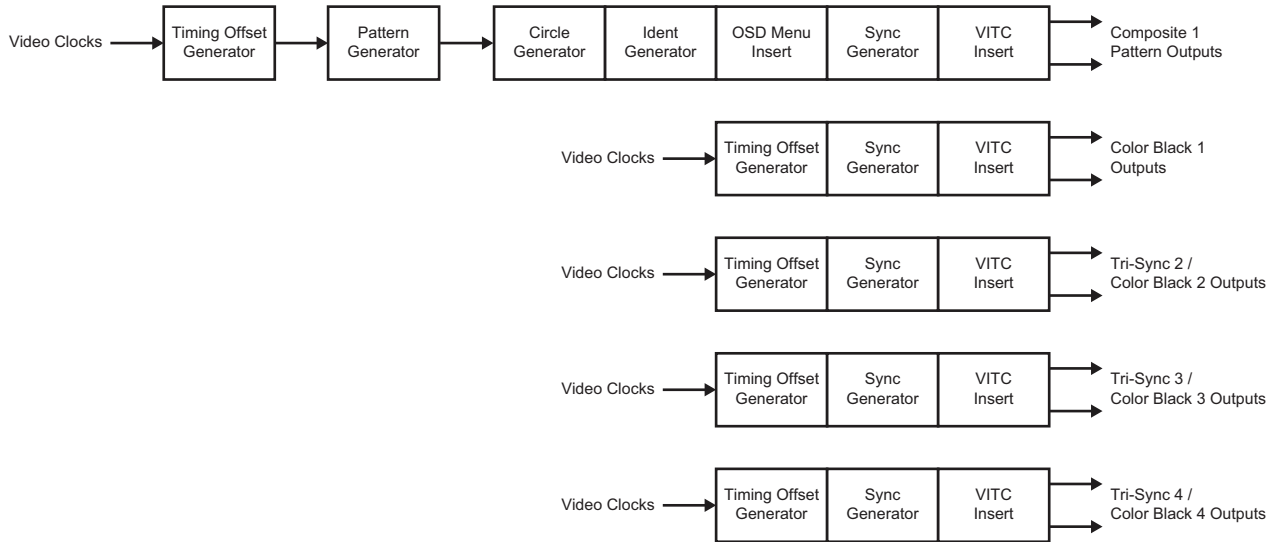

Figure 1.4 Composite Pattern and Tri-Sync/Composite Black Outputs

Timecode

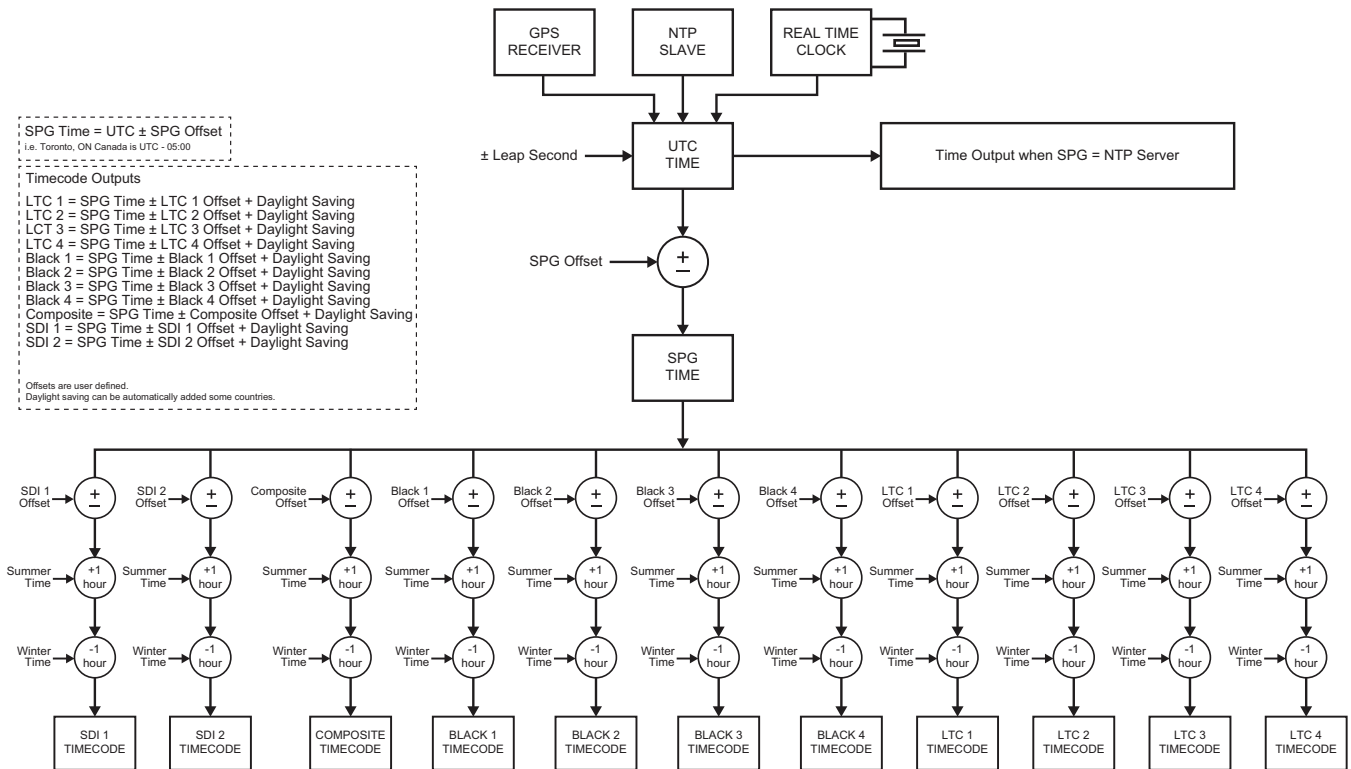

Figure 1.5 Timecode

Signal Processing Modules

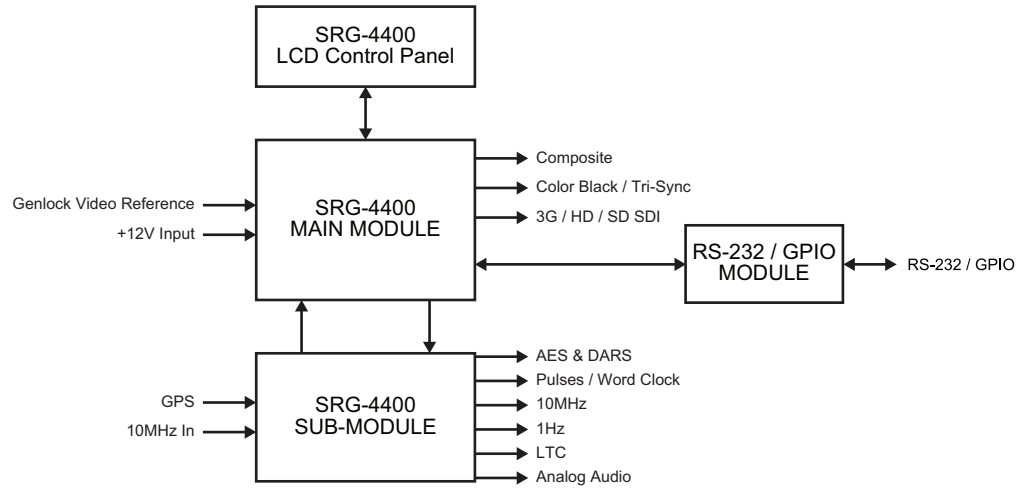

Figure 1.6 Signal Processing

Documentation Terms and Conventions

The following terms and conventions are used throughout this manual.

Terms

The following terms are used:

- “**Almanac**” refers to a set of parameters included in the GPS satellite navigation message that a receiver uses to predict the approximate location of a satellite. The almanac contains information about all of the satellites in the constellation.
- “**CW signals**” refers to continuous wave signals.
- “**Ephemeris**” is a description of the path of a celestial body indexed by time. The navigation message from each GPS satellite includes a predicted ephemeris for the orbit of that satellite valid for the current hour. The ephemeris is repeated every 30 seconds and is in the form of a set of 16 Keplerian-like parameters with corrections that account for the perturbations to the orbit caused by the earth’s gravitational field and other forces.
- “**Epoch**” is an instant of time (or a date) from which values of data are referenced. Note: an Era is the period of time between successive epochs.
- “**GLONASS**” refers to the Global Navigation Satellite System.
- “**GPS**” refers to global positioning system.
- “**Operator**” and “**User**” refer to the person who uses SRG-4400.
- “**RF interference**” refers to radio frequency interference
- “**System**” and “**Video system**” refer to the mix of interconnected production and terminal equipment in your environment.
- “**UTC**” refers to Co-ordinated Universal Time. The time scale based on the atomic second but occasionally corrected, by the insertion of leap seconds, to keep it approximately synchronized with Earth’s rotation. The leap second adjustments keep UTC within 0.9 seconds UT11.

Conventions

The following conventions are used:

- The “**Operating Tips**” and “**Note**” boxes are used throughout this manual to provide additional user information.

Physical Installation

In This Chapter

This chapter provides instructions for installing the SRG-4400.

The following topics are discussed:

- Before You Begin
- Initial Product Inspection
- Operating Environment Requirements
- Rack Mount Installation
- Installing the Breakout PCB
- Connecting Power
- Accessories and Options

Before You Begin

Before installing the SRG-4400, refer to the section “**Important Regulatory and Safety Notices to Service Personnel**” located at the front of this manual for power source, grounding, and other general safety information.

Static Discharge

Throughout this manual, please heed the following cautionary note:



ESD Susceptibility — *Static discharge can cause serious damage to sensitive semiconductor devices. Avoid handling circuit boards in high static environments such as carpeted areas and when synthetic fiber clothing is worn. Always exercise proper grounding precautions when working on circuit boards and related equipment.*

Unpacking

Unpack each SRG-4400 you received from the shipping container and ensure that all items are included. If any items are missing or damaged, contact your sales representative or Ross Video directly.

Initial Product Inspection

Perform the following Initial Product Inspection Procedure when you receive your SRG-4400:

1. Inspect the shipping carton for external damage, which may indicate possible damage to the SRG-4400. If damage exists, document it, including photographs, to support any insurance claim.
2. Remove the instrument from the shipping carton.
3. Check that the SRG-4400 has not been damaged in transit. The exterior should not have any scratches or impact marks. Prior to shipment the SRG-4400 is thoroughly inspected for mechanical defects.
4. Verify that the shipping carton contains the instrument, the standard accessories, and any optional accessories that you ordered.
5. Perform the Functional Check Procedures as outlined in the chapter “**Functional Check Procedures**” on page 3-1 after installing the SRG-4400.



Note — *Save the shipping carton and packaging materials for SRG-4400 re-packaging in case return shipment becomes necessary.*

Operating Environment Requirements

Verify that the location of your installation has the proper operating environment. The SRG-4400 operates correctly in ambient temperatures from 0 °C to +40 °C and relative humidity from 20% to 80%.

For More Information on...

- environmental operating specifications, refer to the appendix “**Specifications**” on page 7-1.

The SRG-4400 requires 50mm (2”) of side clearance for counter top use. Also, ensure sufficient rear clearance, e.g. 75mm (3”), so that cables are not compromised.

The SRG-4400 does not currently have an internal fan to assist with ventilation or cooling. Therefore, when you install the unit in an equipment bay, it is imperative that you ensure there is sufficient space all around the unit to allow the airflow to vent away any excess heat generated by the unit.



Caution — *The SRG-4400 could be damaged if it is powered on at temperatures or humidities outside the specified ranges.*

Rack Mount Installation

You can install the SRG-4400 into an equipment rack. It is recommended to use the rack mount kit and to loom the cables so that they do not introduce extra weight or twisting force on the front panel rack mountings or rear panel connectors. If installed in a mobile application, the rack mount kit is essential.

This section describes how to install the SRG-4400 into the rack.



Warning — To prevent the rack mounted SRG-4400 from tipping forward onto the operator, install the instrument so that the operator will be able to access all of its rear-panel connectors without pushing down on the instrument.

Installing the SRG-4400 into a Rack Unit

The SRG-4400 mounts in the rack cabinet by means of four screws through the front mounting flanges. This should normally be sufficient to carry the load, including weight of cables. Refer to the *SRG-4400 Quick Start Guide* for mounting details.

Installing the Rear Support Brackets



Warning — Do not use the support brackets to carry the SRG-4400. The brackets are not primarily designed for this purpose, and property damage or personal injury may result.

In some cases, (mobile trucks, etc.) it may be desirable to also support the rear of the SRG-4400. The rear support bars can be attached to the SRG-4400 in six possible positions. (Figure 2.1)

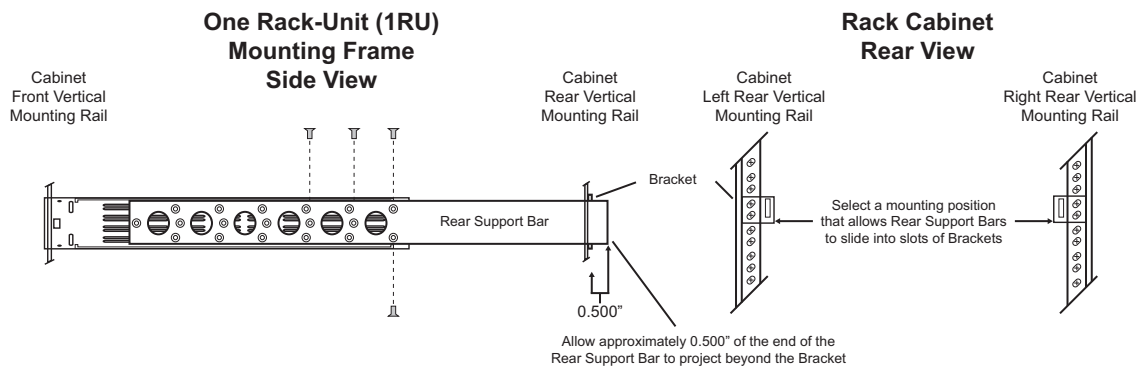

Figure 2.1 Installing the Support Brackets

To install the support brackets

1. Choose the position that suits the cabinet depth and will give approximately a 0.5” projection beyond the previously mounted bracket.
2. Using four screws per bracket, as shown in **Figure 2.1**, attach both bars.
3. Mount the frame to the front rails of the rack cabinet using rack screws.
4. At the rear of the cabinet, slide the bracket slots over the rear of the support bars and secure to the cabinet rear rails with rack screws.

Installing the Breakout PCB

The Breakout PCB for the SRG-4400 enables you to cable a Primary SRG-4400 and a Backup SRG-4400 to an ACO-4400A but still retain access to the AES, DARS, and Analog Audio connections on balanced 3-pin connectors.

Installing the Breakout PCB requires:

1. Installing the Breakout PCB on the Rack Tray
2. Installing the Breakout PCB into the Rack Frame
3. Connecting the Breakout PCB to the SRG-4400
4. Cabling the Connectors on the Breakout PCB

Before You Begin

Before installing the Breakout PCB, refer to the section “**Important Regulatory and Safety Notices to Service Personnel**” located at the front of this manual for power source, grounding, and other general safety information.

Static Discharge

Throughout this manual, please heed the following cautionary note:



ESD Susceptibility — *Static discharge can cause serious damage to sensitive semiconductor devices. Avoid handling circuit boards in high static environments such as carpeted areas and when synthetic fiber clothing is worn. Always exercise proper grounding precautions when working on circuit boards and related equipment.*

Unpacking

Unpack each SRG-4400 Install Kit you received from the shipping container and ensure that all items are included. If any items are missing or damaged, contact your sales representative or Ross Video directly.

Required Equipment

Table 2.1 summarizes the items that are required

Table 2.1 SRG-4400 Install Kit Items

Part Number	Description	Quantity
70-00994	Rack frame tray for the Breakout PCB	1
8399AR-032	Breakout PCB	1
4101-3004-RC	M3 5mm screws for the rear brackets and tray	8
88-00995	M3 10mm screws with lock washers	4
4400CR-100	30-pin Molex cable (red and violet wires)	1

Installing the Breakout PCB on the Rack Tray

You will need a Phillips screwdriver to affix the Breakout PCB to the rack tray using the four M3 10mm screws that were included in the SRG-4400 Install Kit.

For More Information on...

- installing the rear support brackets into the rack frame, refer to the section “**Installing the Rear Support Brackets**” on page 2-5.

To install the Breakout PCB on the rack tray

1. Position the Breakout PCB atop the screw posts on the tray. Refer to **Figure 2.2**.

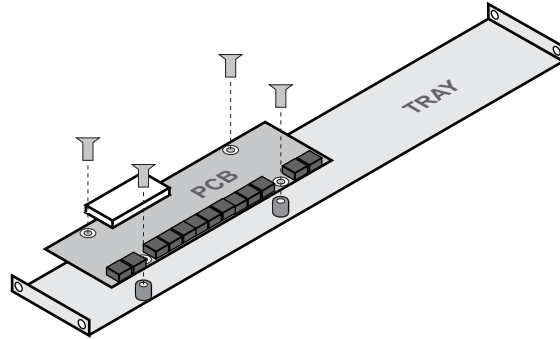

Figure 2.2 *Installing the Breakout PCB on the Rack Tray*

2. Affix the Breakout PCB using the provided four M3 10mm screws with lock washers (88-0095).

Installing the Breakout PCB into the Rack Frame

The Tray installs between the rear support brackets so that the 30-pin connector is aligned with the **BALANCED** 30-pin connector on the SRG-4400 rear panel. This section outlines how to affix the tray to the rear support brackets.

To install the Breakout PCB in the rack frame

1. Position the Breakout PCB and Tray behind the SRG-4400 in the rack frame (**Figure 2.3**) while ensuring to:
 - position the Breakout PCB so that its white 30-pin connector is aligned with the SRG-4400 rear panel 30pin connectors;
 - leave enough space between the SRG-4400 rear panel and the Breakout PCB to properly cable the connectors.

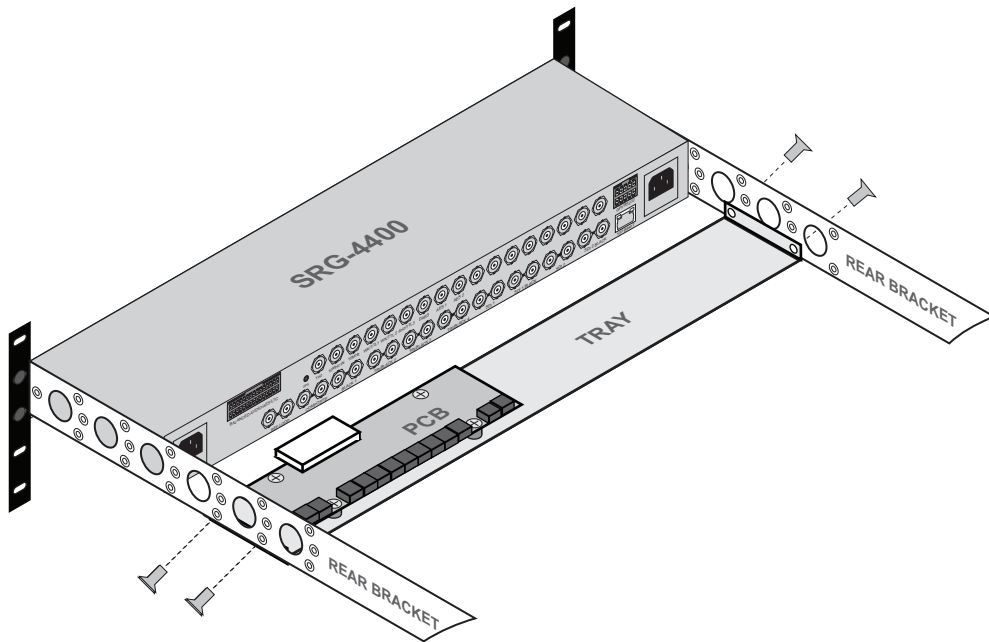

Figure 2.3 Installing the Breakout PCB and Tray to the Rear Brackets.

2. Use the 4 provided M3 5mm screws to affix the Breakout PCB and Tray to the Rear Brackets of the SRG-4400. Refer to **Figure 2.3**.

Connecting the Breakout PCB to the SRG-4400

The Breakout PCB connects to the SRG-4400 rear panel via the provided Interface Cable (4400CR-100). This cable type has red and violet wires, and two 30-pin Connectors.

For More Information on...

- using the Breakout PCB in a redundant system with an ACO-4400A, refer to the *ACO-4400A User Manual*.

To connect the Breakout PCB to the SRG-4400

1. Connect one end of the Interface Cable to the connector on the Breakout PCB.

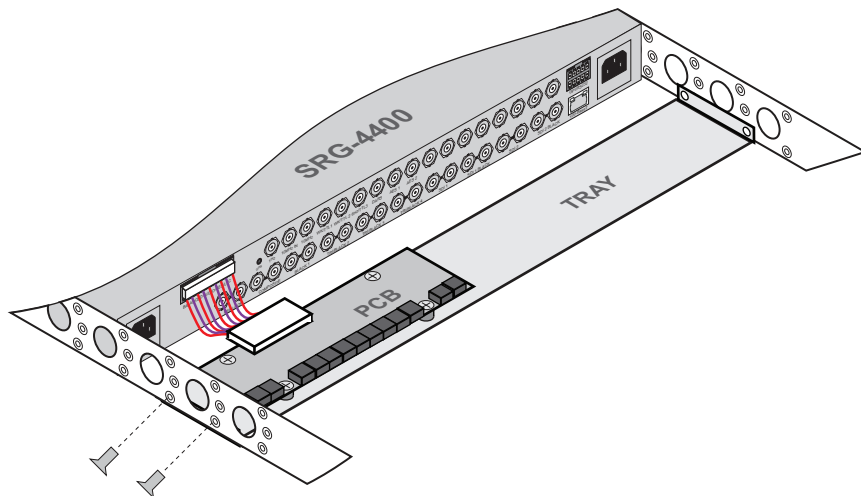

Figure 2.4 Connecting the Breakout PCB to the SRG-4400 Rear Panel

2. Connect the other end of the same Interface Cable to the **BALANCED** Connector on the SRG-4400 rear panel. Refer to **Figure 2.4**.

Cabling the Connectors on the Breakout PCB

The Breakout PCB provides a series of 3-pin terminal blocks with removable connectors that provides access to the AES, DARS, and Analog Audio connections. This section outlines the pinout designations and how to wire the 3-pin connectors.

Figure 2.5 illustrates the pinout assignment of the Breakout PCB 3-pin connectors. Each connector has locations for the positive, negative, and grounded wires. This information is also included in the PCB silk-screen.



Note — The functions of Pins 3-18 are assigned in the software. Refer to the section “**Programmable Balanced Outputs**” on page 5-47 for details.

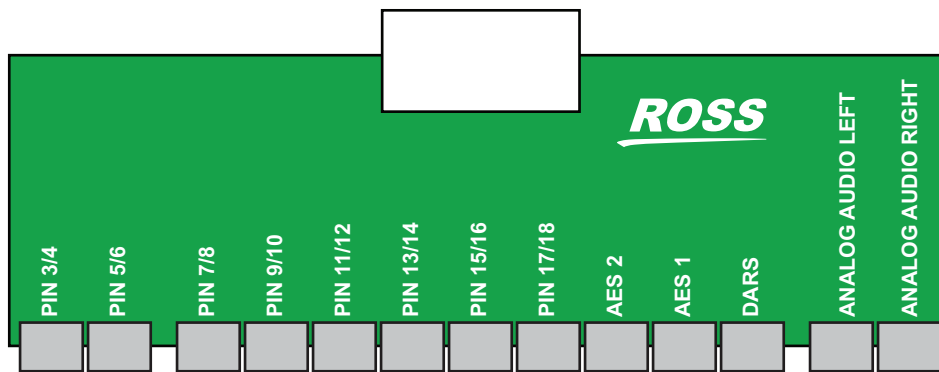

Figure 2.5 Breakout PCB — Top View of Connectors

To wire a 3-pin connector

1. Insert a wire to the designated polarity slot on the connector of the rear panel. (**Figure 2.6**)

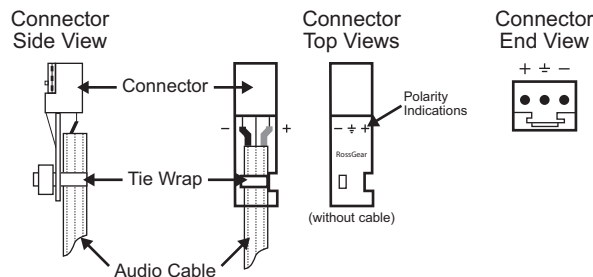

Figure 2.6 Connector Wiring for the Breakout PCB 3-pin Connectors

2. Use a tweaker screwdriver to tighten the corresponding capture screw.
3. Repeat steps 1 and 2 for each wire on each connector.
4. Once the cables are wired to the connectors, install the connectors on the terminal blocks of the Breakout PCB.

Connecting Power

The SRG-4400 operates from a single-phase power source with the neutral conductor at or near earth ground. The line conductor is fused for over-current protection. A protective ground connection through the grounding conductor in the power cord is essential for safe operation. Safety earth studs are also provided for earth bonding the chassis if you so require.

Your SRG-4400 includes the N+1 power option (PS-4400), you need to provide two power connections. For full power security, these should be on separate, independent and secure power grids. However, you still gain the security of power supply failure redundancy if you use the same power grid for both connections.

AC Power Requirement

Check that your location provides the proper electrical power requirements as listed in **Table 2.2**.

Table 2.2 AC Line Power Requirement

Parameter	Description
Line Voltage Range	120-230V
Line Frequency	50-60Hz
Maximum Power (Single PSU)	31VA (~14W - calculated)
	<130mA @ 230VAC <210mA @ 120 VAC
Maximum Power (Dual PSU)	46VA (~21W - calculated)
	<130mA @ 230VAC <210mA @ 120 VAC

Connecting the Power Cable

Connect the power cable to the instrument first, and then connect it to the AC power source. Note that connecting a live power cable causes the instrument to power on.



Caution — *The SRG-4400 does not have a power switch.*

Replacing a Power Supply

To replace a power supply, you must remove the faceplate from the chassis to gain access to the power supplies. This section summarizes how to replace a power supply in your SRG-4400.

To replace a power supply

1. Remove the four front screws from the control panel faceplate.

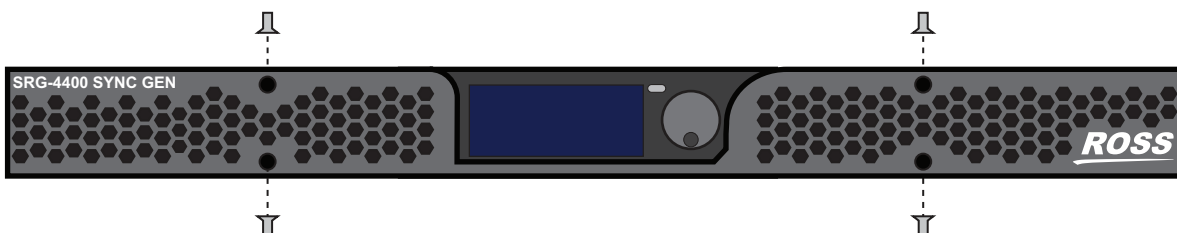

Figure 2.7 Removing the Faceplate Screws

2. Remove the faceplate by gently pulling it towards you and away from the chassis. The screws are self-retained in their holes.

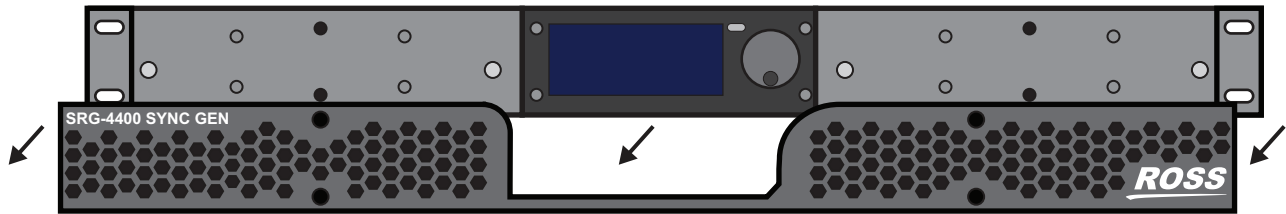

Figure 2.8 Removing the Faceplate

3. Each power supply includes two screws that must be removed before the power supply can be removed from the chassis. Refer to **Figure 2.9** for the screw locations on each power supply.



Figure 2.9 Screw Locations on Each Power Supply

4. Remove a power supply by gently pulling it towards you and away from the chassis.

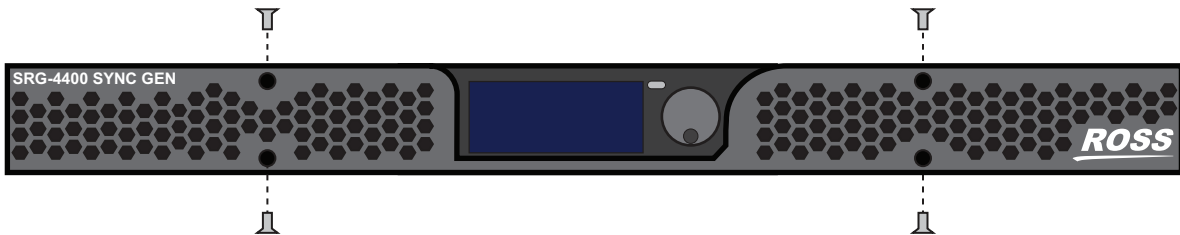

Figure 2.10 Removing the Power Supplies from the Chassis

5. Install the new power supply as follows:
 - Sliding the new power supply into the available slot.
 - Secure the power supply into its slot via the provided screws.
6. Position the faceplate over the power supplies.
7. Secure the faceplate on the chassis using the provided screws.



Figure 2.11 Re-installing the Faceplate

Accessories and Options

This section lists the standard accessories that ship with the SRG-4400 and the available software options that you can purchase.

Standard Accessories

The following accessories are shipped with the SRG-4400.

User Documentation Disc

A Documentation Resources disc was included with your SRG-4400.

Power Cords

All SRG-4400 are shipped with one of the following power cord options:

- Power cords for use in the United Kingdom are BS1363 approved.
- Power cords for use in North America are UL listed and CSA certified.
- Power cords for use in Europe conform to CEE7, DIN49441 and VDE standards.
- Cords for use in other areas are approved by at least one authority acceptable in the country to which the product is shipped.

Additional Software Options

You can order the following software options for your SRG-4400:

- SRG-4400-GPS — Enables GPS Time Synchronization
- SRG-4400-NTP — Enables NTP Time Synchronization

Functional Check Procedures

In This Chapter

Perform the following procedures if you are operating the SRG-4400 for the first time (to verify that the SRG-4400 shipped without damage), or you suspect that the SRG-4400 is not working properly.

The following topics are discussed:

- Required Equipment
- Before You Begin
- Initial Power-Up
- Initial Configuration
- Check Outputs
- Operational Configuration

Required Equipment

The following equipment is required for the functional check:

- TV signal generator
- Multi-format waveform/picture monitors
- Serial digital video analyzer with embedded audio functionality
- Digital audio de-embedder
- AES/EBU digital audio analyzer
- Analog audio analyzer
- Oscilloscope
- 75ohm BNC cables
- 75ohm terminations
- Breakout cable/box for the rear panel 30-way multi-way connector (not supplied by Ross Video)

Before You Begin

The following procedures will guide you through the steps required to check the operation of the SRG-4400. The most common scenarios will be explored to enable the user to familiarize themselves with the operation of the unit. Although some steps are included which suggest cycling through menu options in order to check operation, this is not mandatory - a simple check for presence or absence of a signal will suffice. Full details regarding the options available in each of the menus are described in the chapter “**Menu System**” on page 5-1 of this manual. The scenarios to be explored are:

1. Initial Power-Up
2. Initial Configuration
3. Check Outputs
4. Time and Timecode settings
5. Genlock Mode
6. System Functions
7. Operational Configuration

Initial Power-Up

1. Ensure that the SRG-4400 is not powered on.
2. Connect any relevant video cables to the SRG-4400, with reference to the Rear Panel layout diagram in the section “**Rear Panel Overview**” on page 4-4.
3. Apply power to the SRG-4400 by connecting it to the power source(s). The instrument runs its power-on initialization process.
4. Check that no error messages appear on the LCD display.
5. The Front Panel menu display can also be made to simultaneously appear on any of the video outputs - there is a menu entry for each output to enable this facility. By default, the menu is enabled on all video outputs.
6. Much of the functional check can be carried out immediately. However, some calibration settings are only guaranteed once functional temperature has stabilized (which should occur after 20 minutes). It is good practice to soak the instrument before proceeding.
7. Selecting or editing menu items requires you to turn the Rotary Control in order to select or change the highlighted menu item / setting, then to press the Rotary Control to select or confirm that menu item / setting.
 - Pressing the Rotary Control will either select the highlighted menu item for editing, exit menu item editing, or take you to the next menu level.
 - Note that there may be more menu lines available than can be displayed on the LCD screen or video outputs; be sure to scroll down (or up) to find the required entry.
8. Pressing the blue push-button once will exit the current menu level or item.
 - When you have finished editing the menu options, you should use the blue push-button to exit the menu system completely.
 - You need to press the button a suitable number of times to get back to the stand-by screen (the one with the Ross Video logo). This will save any changes that you have made to the non-volatile memory.
9. If preferred, user settings can be adjusted using DashBoard.

Recommendation

The SRG-4400 menu system contains an appreciable number of pre-programmed and user selectable settings. All of these settings are programmed using the factory default procedure, and a select few are then adjusted during testing and alignment. This is especially true of the Calibration menu, where settings relating to the fundamental operation of each individual SRG-4400 are stored. If memory corruption occurs, some or all of the settings may need to be re-instated.

For More Information on...

- the entire menu system; each sub-section starts with a menu listing, which when printed out could be used to record your individual menu settings, refer to the chapter “**Menu System**” on page 5-1.

Initial Configuration

The SRG-4400 should arrive configured to a “factory default” condition, i.e. all video outputs will have a pattern selected that is relevant to the format of the output, all of the audio channels will be configured for “1kHz Tone and Silence”, etc.

Additionally, any pre-ordered options (i.e. GPS or NTP) will have been enabled. This can be confirmed by viewing the Option Enable page in the menu; enabled options will have valid Option Keys entered for them. Refer to the section “**System Setup Menus**” on page 5-39 for more details.

The following procedures will systematically progress through all of the outputs available from the SRG-4400. The range of menu entries available for each procedure may relate to whether associated options have been enabled.

In all but the first of the procedures that follow, some intermediate instructions relating to cursor movements and control button presses may have been omitted for clarity.

Also, menu screens almost always contain more lines than can be displayed on the LCD or the OSD - be sure to scroll up/down to find the menu entry you require.



Note — *[Confirm]* indicates that you should press the Rotary Control, and *[Back]* indicates that you should press the blue push-button.

Check Outputs

Composite (Analog) Video Signal Outputs:

From the Top Level menu:

1. Highlight < -Video >.
2. [Confirm].
3. Highlight the top menu line.
4. [Confirm].
5. Select < Video Channel 05 = Composite 1 >.
6. [Confirm].
7. Connect the Composite Video output to a Waveform / Picture Monitor using a 75ohm BNC cable.
8. Set the Waveform / Picture Monitor to view the Composite signal.
9. Check that the Waveform / Picture Monitor displays the appropriate Composite signal.
10. Check that the Composite signal is as configured in the menu, and that selecting and editing entries in the menu by using the rotary/push control, the configuration of the Composite signal changes accordingly.
11. Return to the Top Level menu using the [Back] button.

Black 1 (Analog) Video Signal Outputs



Note — *The format of the Analog Black 1 output follows that of the Composite output; consequently, the format of this output cannot be changed from within the < Black 1 > menu.*

From the Top Level menu:

1. Select < -Video >.
2. Select < Video Channel 07 = Black 1 >.
3. Connect the Black 1 video output to the Waveform / Picture Monitor using a 75ohm BNC cable.
4. Set the Waveform / Picture Monitor to view the Black 1 signal.
5. Check that the Waveform / Picture Monitor displays the appropriate Black 1 signal.
6. Check that the Black 1 signal is as configured in the menu, and that selecting and editing entries in the menu by using the rotary/push control, the configuration of the Black 1 signal changes accordingly.
7. Return to the Top Level menu using the [Back] button.

Tri-Black 2 / 3 / 4 Tri-Level Sync Outputs



Note — *The Tri-Black 2 / 3 / 4 outputs can be configured to produce either traditional “bi-level” Color Black (i.e. PAL / NTSC) or Tri-Level syncs.*

Bi-Level Color Black is always available. Tri-Level Syncs are only available if the associated Option Key has been entered; otherwise, the selection of output format is restricted.

From the Top Level menu:

1. Select < -Video >.
2. Select < Video Channel 08 = Tri Black 2 >.
3. Connect the Tri-Black 2 output to an oscilloscope or suitable Analyzer using a 75ohm BNC cable.
4. Set the oscilloscope / Analyzer to view the Tri-Black 2 signal.
5. Check that the oscilloscope / Analyzer displays the appropriate Tri-Black 2 signal.
6. Check that the Tri-Black 2 signal is as configured in the menu, and that selecting and editing entries in the menu by using the rotary/push control, the configuration of the Tri-Black 2 signal changes accordingly.
7. Return to step 2, set for < Video Channel 09 = Tri Black 3 >, and repeat steps to check the Tri-Black 3 outputs.
8. Return to step 2, set for < Video Channel 10 = Tri Black 4 >, and repeat steps to check the Tri-Black 4 outputs.
9. Return to the Top Level menu using the [Back] button.

Serial Digital Video Signal Outputs



Note — *The format of the SDI Black 1 (and 2) output(s) follows that of the associated SDI Pattern output; i.e. they operate as a pair of “linked” outputs.*

Each SDI Video output channel can be configured to produce SD-SDI, HD-SDI or 3G-SDI. SD-SDI Video outputs are always available. HD- and 3G-SDI outputs are only available if the associated Option Keys have been entered; otherwise, the selection of output format is restricted.

From the Top Level menu:

1. Select < -Video >.
2. Select < Video Channel 01 = SDI+Black 1 >.
3. Connect the SDI1 Pattern output to the Serial Digital Video Analyzer using a 75ohm BNC cable.
4. Set the Serial Digital Video Analyzer to view the Serial Digital Video signal.
5. Check that the Serial Digital Video Analyzer displays the appropriate Serial Digital Video signal. If available, check the status of the Serial Digital Video signal on the Analyzer by setting it to display the relevant data.
6. Check that the Serial Digital Video signal is as configured in the menu, and that selecting and editing entries in the menu by using the rotary/push control, the configuration of the Serial Digital Video signal changes accordingly.
7. Move the 75ohm BNC cable to the SDI1 Black output.

8. Repeat steps 4 - 6 to confirm the configuration of the SDI1 Black output.
9. Return to step 2, set for < Video Channel 02 = SDI+Black 2 >, and repeat steps to check both of the SDI2 outputs.
10. Return to the Top Level menu using the [Back] button.

SDI Embedded Audio Settings

Audio channels on the SDI outputs are arranged as 8 stereo pairs on each video output:

- SDI 1 Pattern 01 ... 16
- SDI 1 Black 01 ... 16
- SDI 2 Pattern 01 ... 16
- SDI 2 Black 01 ... 16.

From the Top Level menu:

1. Select < -Audio >.
2. Select < SDI 1 Pattern Left = Audio 01 >.
3. Connect the SDI1 Pattern video output to the Serial Digital Video Analyzer or to a Digital Audio De-Embedder using a 75ohm BNC cable.
4. Set the Analyzer / De-Embedder to display the status of the audio data, and to receive a signal through the connected input.
5. Check that the Analyzer / De-Embedder does not report any data errors, etc.
6. Check that the Digital Audio signal is as configured in the menu, and that selecting and editing entries in the menu by using the rotary/push control, the configuration of the Digital Audio signal changes accordingly.
7. Repeat steps 3 - 6 for menu selection:
< SDI 1 Pattern Right = Audio 02 > on SDI1 Pattern video output.
8. Repeat steps 3 - 6 for menu selections:
< SDI 1 Pattern Left / Right = Audio 03....16 > on SDI1 Pattern video output.
9. Repeat steps 3 - 6 for menu selections:
< SDI 1 Black Left / Right = Audio 01....16 > on SDI1 Black output.
10. Repeat steps 3 - 6 for menu selections:
< SDI 2 Pattern Left / Right = Audio 01....16 > on SDI2 Pattern video output.
11. Repeat steps 3 - 6 for menu selections:
< SDI 2 Black Left / Right = Audio 01....16 > on SDI2 Black output.
12. Return to the Top Level menu using the [Back] button.

AES / EBU Audio Outputs



Note — *AES/EBU Audio Outputs are only available when the multifunction sub-module is installed.*

Audio channels on the AES outputs are arranged as stereo pairs on each output:

- AES 1 01 02

- AES 2 01 02 etc, to
- AES 8 01 02

Before proceeding, connect a suitable Breakout cable/box to the 30-pin Multi-way connector on the rear panel.

From the Top Level menu:

1. Select < -Audio >.
2. Select < Audio AES1 Left = Audio 01 >.
3. From the Breakout cable/box, connect AES Audio Channel 01 to your Digital Audio Analyzer input.
4. Set the Digital Audio Analyzer to display the status of the audio data, and to receive a signal through the connected input.
5. Check that the Analyzer does not report any data errors, etc.
6. Check that the Digital Audio signal is as configured in the menu, and that selecting and editing entries in the menu by using the rotary/push control, the configuration of the Digital Audio signal changes accordingly.
7. Repeat steps 3 - 6 for menu selection
< Audio AES1 Right = Audio 02 > and breakout connection AES Audio Channel 02.
8. Repeat steps 3 - 6 for menu selections:
< Audio AES 2....6 Left / Right = Audio 03....12 > and breakout connections AES Audio Channel 03 through 12.
9. AES7 and AES8 Audio outputs will only appear on the rear panel multi-way connector of the sub-module if the relevant menu items have been suitably configured. Refer to the section “**System Functions**” on page 3-11 for more details on where these settings are.
10. Repeat steps 3 - 6 for menu selections:
< Audio AES 7....8 Left / Right = Audio 13....16 > and breakout connections AES Audio Channel 13 through 16.
11. Return to the Top Level menu using the [Back] button.

Analog Audio Outputs



Note — *Analog Audio Outputs are only available when the multifunction sub-module is installed.*

Audio channels on the Analog Audio outputs are arranged as a stereo pair: Analog 01 ... 02

Before proceeding, connect a suitable Breakout cable/box to the 30-pin Multi-way connector on the rear panel.

From the Top Level menu:

1. Select < -Audio >.
2. Select < Audio Analogue1 Left = Audio 01 > [2nd to last entry in the list].
3. From the Breakout cable/box, connect Analogue Audio Channel 01 to your Analog Audio Analyzer input or to an oscilloscope.
4. Set the Analog Audio Analyzer / oscilloscope to display the audio signal, and to receive a signal through the connected input.

5. Check that the Analog Audio signal is as configured in the menu, and that selecting and editing entries in the menu by using the rotary/push control, the configuration of the Analog Audio signal changes accordingly.
6. Repeat steps 3 - 5 for menu selection:
 < Audio Analog1 Right = Audio 02 > [Last entry in the list] and breakout connections Analog Audio Channel 02.
7. Return to the Top Level menu using the [Back] button.

Time and Timecode Settings

Each video output has its own dedicated Timecode generator, which can be offset from the main SPG Time. Additionally, there are dedicated LTC outputs which can be similarly offset. There are also several Timecode system-related setup screens. This procedure will acquaint the user with the available options. Refer to **Figure 1.5** for a functional diagram of the Timecode system.

The following Timecode menu screens are available:

- SDI 1 & SDIBlack 1 Timecode
- SDI 2 & SDIBlack 2 Timecode
- Composite 1 VITC Black 1 VITC
- Tri-Sync Black 2 VITC
- Tri-Sync Black 3 VITC Tri-Sync Black 4 VITC LTC 1 Timecode
- LTC 2 Timecode
- LTC 3 Timecode
- LTC 4 Timecode
- SPG Time
- UTC DateTime
- GPS DateTime (UTC) NTP DateTime (UTC)
- Analog REF VITC (UTC) Digital REF TC (UTC)
- Summer DST Event (UTC) Winter DST Event (UTC) Leap Second Event (UTC)

Full details regarding the setting of UTC Time, SPG Time, Summer & Winter DST Events, and Leap seconds can be found in section “**Timecode Menus**” on page 5-21. A flow chart outlining the Time and Date Configuration sequence is shown in **Figure 5.14** in the same section.

From the Top Level menu:

1. Select < -Timecode >.
2. Select < SDI 1 & SDIBlack 1 Timecode >.
3. Line 2 of the menu confirms the format of the selected video output.
4. Line 3 of the menu displays the channel time - “Running Time”.
5. Line 4 of the menu allows the user to input an offset from the current SPG Time to appear on the selected video output.
6. < Offset = SPGTime + hh.mm.ss.ff > (where hh.mm.ss.ff are hours. minutes.seconds. Frames - may have non-zero entries relating to an offset that has already been entered).
7. Repeat steps 3 - 6 for < SDI 2 & SDIBlack 2 Timecode >.
8. Repeat steps 3 - 6 for < Composite 1 VITC >.
9. Repeat steps 3 - 6 for < Black 1 VITC >.

10. Repeat steps 3 - 6 for < Tri-Sync Black 2-4 VITC >.
11. Repeat steps 3 - 6 for < LTC 1-4 Timecode >.
12. Return to the Top Level menu using the [Back] button.

Genlock Mode

From the Top Level menu:

1. Select < -Genlock >.
2. Select < Lock Mode >.
3. Select < Internal Lock > from the list.
4. Check that < -Lock Status > confirms the instrument is using the internal reference.
5. Check that < -Ref Status > confirms the instrument has not detected an external reference.
6. Using a 75ohm BNC cable, connect Color Black from the TV signal generator to the SRG-4400 REF-LOOP input BNC connector. Terminate the unused REF-LOOP connector with a 75ohm termination.
7. Check that < -Lock Status > confirms the instrument is locked. If a valid signal has been connected, < -Lock Status > will usually sequence through the states:
 - Internal Lock
 - Locking
 - Locked
8. Check that < -Ref Status > confirms the instrument has detected an external reference by indicating the format of the signal you have connected to the REF- LOOP input.
9. Select < Lock Mode >.
10. Select < Genlock 1 > from the list.
11. Check that < -Lock Status > confirms the instrument is locked to the external reference.
12. Once you have selected < Genlock 1 > the SPG will Genlock the video outputs to the external reference if it is a valid signal. This can be confirmed on an oscilloscope or a vector-scope.
13. Disconnect the external reference from the REF-LOOP connector.
14. < -Lock Status > should now indicate Internal Lock, and < -Ref Status > should now indicate No signal.
15. Return to the Top Level menu using the [Back] button.

System Functions

From the Top Level menu:

1. Select < -System Setup>.
2. Select < -Temp Report >. This screen displays the current temperatures of any installed sensors.
3. Return to the System Setup menu using the [Back] button.
4. Select < -Event Report >. This screen displays the latest reported system events.
5. Return to the System Setup menu using the [Back] button.

6. Select < -System Report >. This menu screen reports the various system version numbers.
7. Return to the System Setup menu using the [Back] button.
8. Select < -GPS Report >. This menu screen reports the status of the GPS receiver sub-system.
9. Return to the System Setup menu using the [Back] button.
10. Select < Configuration >.
11. Select < Changeover > to define whether the SRG-4400 is the Primary or the Backup unit in a changeover pair.
12. Select < LCD Brightness > to select the brightness of the LCD screen.
13. Select < AES1-8 + Analog > to select the reference source for the AES and Analogue audios.
14. Select < AES7 Output is > to select AES channel 7 or LTC channel 3 to appear on the relevant pin(s) of the multi-way connector on the multifunction sub-module.
15. Select < AES8 Output is > to select AES channel 8 or LTC channel 4 to appear on the relevant pin(s) of the multi-way connector on the multifunction sub-module.
16. Select < Pulse 1 > to select a pulse type to appear at the relevant rear panel BNC of the multifunction sub-module.
17. Repeat with < Pulse 2 > and < Pulse 3 > to select pulse types at the relevant rear panel BNCs of the multifunction sub-module.
18. Select < 10MHz Mode > to select the source of a 10MHz reference.
19. Return to the Top Level menu using the [Back] button.

Network Settings

The Network menu can be reached via the < -System Setup> menu option.

Many of the parameters that can be configured in this menu require the operator to obtain details from a Network Administrator. Once configured, they are unlikely to change.

Changes to this menu are likely to occur very rarely, and so no formal description will be outlined here. For the purposes of this functional check, simply scroll through the menu (and sub-menus) to check for any corrupted entry. Refer to the relevant pages in the section “**System Setup Menus**” on page 5-39 for details of the various options.

Option Enable Settings

The Option Enable menu can be reached via the < -System Setup > menu option.

This menu screen lists the installed Option Keys for enabled options within the SRG-4400.

Changes to this menu are extremely unlikely to occur, and so no formal description will be outlined here. For the purposes of this functional check, simply scroll through the menu to check for any corrupted entry. Refer to the section “**System Setup Menus**” on page 5-39 for details of the various options.

Calibration Settings

The Calibration menu can be reached via the < -System Setup > menu option. This menu screen lists the system calibration values for the SRG-4400.

Changes to this menu are extremely unlikely to occur, and so no formal description will be outlined here. For the purposes of this functional check, simply scroll through the menu to check for any corrupted entries. Refer to the section “**System Setup Menus**” on page 5-39 for details of the various options.

Operational Configuration

There are several configuration factors that will influence the initial installation of your SRG-4400, namely:

- Mains Power
- Time, Date, DST etc.
- Video and Audio outputs
- References (Genlock, 10MHz, GPS, NTP, etc.)
- Network
- Connection to ACO-4400A Changeover unit

The user should refer to the various sections of this manual that explain each of these features, so that they may correctly configure the SRG-4400 to their requirements.

Operating Basics

In This Chapter

This chapter outlines the basics of operating the SRG-4400.

The following topics are discussed:

- Front Panel Overview
- Rear Panel Overview
- Operating Basics
- Software Upgrades

Front Panel Overview

Figure 4.1 shows the SRG-4400 Front Panel. Descriptions of the Front Panel controls and indicators appear below.

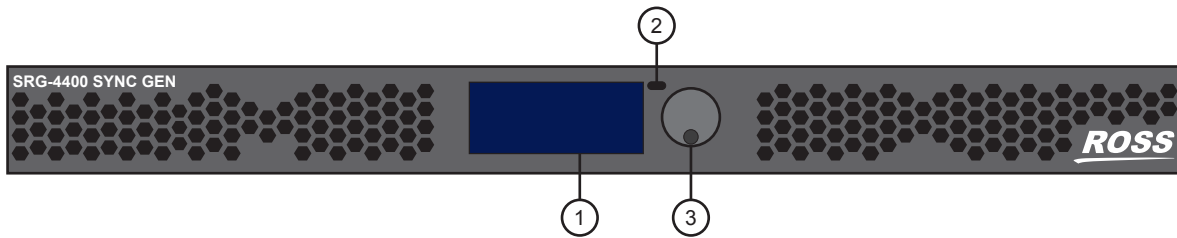

Figure 4.1 SRG-4400 — Front Panel

1. LCD Display

The dot-matrix LCD display is used to show system status, fault indications, and general in-use information, as well as being used to configure the menu system items.

2. Back Button

The **Back** push-button is used to exit the current menu screen, and to traverse back through the menus, ultimately to the stand-by screen.

Pressing the dedicated push-button once will exit the current menu level. When you have finished editing the menu options, you should use the dedicated push-button to exit the menu system completely. You need to press the button a suitable number of times to get back to the stand-by screen (the one with the Ross Video logo, one press *back* from the top level menu). This will save any changes that you have made to the non-volatile memory.

Pressing the **Back** button while pressing the **Rotary/Push Control** knob at the same time will lock the front panel controls. Pressing both again will unlock the front panel controls.

3. Rotary / Push Control Knob

The Rotary / Push control has two functions:

- the rotary function is used to navigate up or down items in a menu, or to cycle through a range of values relating to a menu item,
- the push function is used to confirm a menu item selection for editing, to exit menu item editing, or take you “forward” to the next menu item.

Selecting or editing menu items requires you to turn the Rotary Control in order to select or change the highlighted menu item / setting, then to press the Rotary Control to select or confirm that menu item / setting. Pressing the Rotary Control will select the highlighted menu item for editing, exit menu item editing, or take you to the next menu level. Note that there may be more menu lines available than can be displayed on the LCD screen; be sure to scroll down (or up) to find the required entry.

For some menu items, there may be many values to scroll through. In order to assist in quickly accessing the required value(s), software monitoring the signals from the rotary control applies a ballistic response to modify the rate at which the menu values change:

- If the rotations/second occur at a reasonably constant rate, the speed at which menu values change will increase exponentially.
- If the rotations/second decreases, the ballistic response also decreases.
- If the rotations/second stops for more than 1 second, then the ballistic response resets to normal action.
- Switching the rotation direction will preserve the modified rate, assuming that the direction change occurred with minimal delay.

4. Removable Power Supplies (not shown)

There are two Removable Power Supply assemblies, installed and secured into the front of the SRG-4400, either side of the LCD display. These supplies can be removed or inserted while mains power is still present. Should it become necessary to replace one or both of the Removable Power Supply assemblies, the instrument does not have to be removed from the rack.

Rear Panel Overview

Figure 4.2 shows the SRG-4400 Rear Panel with descriptions of the rear-panel connectors.

In the basic configuration, the entire bottom row of BNCs are present, together with the Ethernet connector and the GPI/RS232 facility. Also, the left-hand group of connectors along the top row will be present.

The remaining BNC holes (top row, right-hand group - currently not implemented) may be used for future option modules.

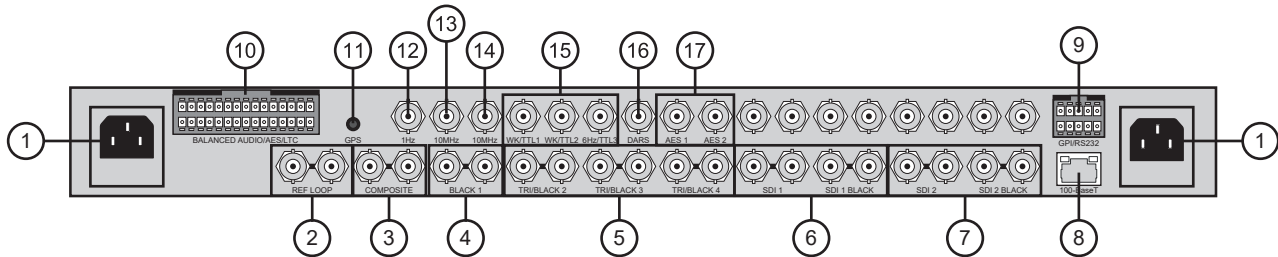

Figure 4.2 SRG-4400 — Rear Panel

1. Power Connectors

The SRG-4400 is designed to operate from a single-phase power source with the neutral conductor at or near earth ground. The line conductor is fused for over-current protection. A protective ground connection through the grounding conductor in the power cord is essential for safe operation. Safety earth studs are also provided for earth bonding the chassis if you so require.



Warning — Do Not Operate Without Covers. Do not operate this product with covers or panels removed.

The SRG-4400 operates from an AC line frequency of 48Hz to 63Hz, over the range of 85VAC to 250VAC, without the need for user configuration. Refer to the chapter “Specifications” on page 7-1 for additional information on power and environment requirements.

You need to provide two power connections (for the two Power Connectors). For full power security, these should be on separate, independent and secure power grids. However, you still gain the security of power supply failure redundancy if you use the same power grid for both connections.

2. REF LOOP

This pair of BNCs allow the input of a remote reference signal. This signal may be NTSC or PAL B/G.

With the reference signal applied to one BNC, the other BNC must be terminated (or connected to another unit which is ultimately terminated).

If the SRG-4400 is to be used as a Master reference (i.e. not Genlocked), you do not have to supply a signal, and you may leave these BNCs unconnected. However, it is always wise to add a termination onto one BNC of an unused looping pair, in order to avoid having a “floating” input.

3. COMPOSITE Output

This pair of BNCs provides two outputs of the selected Analog Composite Video Pattern. The output format can be PAL, NTSC-M or NTSC-J.

4. BLACK 1 Output

This pair of BNCs provides two outputs of Analog Composite Video Black-Burst. The output format is always the same as that selected on the COMPOSITE output.

5. TRI / BLACK 2, 3, and 4 Outputs

These three pairs of BNCs provide two outputs each of either Analog Composite Video Black-Burst in PAL, NTSC-M or NTSC-J, or any one of the supported Tri-Level Sync formats. These three pairs of outputs are completely independent from each other.

6. SDI 1 and SDI 1 BLACK Outputs

These two pairs of BNCs provide two outputs each of the selected pattern and black in Standard Definition, High Definition or 3G Video, in any of the supported formats. The signal format of the black output follows that of the Pattern output.

7. SDI 2 and SDI 2 BLACK Outputs

These two pairs of BNCs provide two outputs each of the selected pattern and black in Standard Definition, High Definition or 3G Video, in any of the supported formats. The signal format of the black output follows that of the Pattern output.

8. Ethernet 100-Base T

This rear-panel connector is a standard RJ45 Ethernet connector. This connection is required for DashBoard connectivity, NTP services, software upgrades, etc.

9. GPI / RS232

This port is not implemented.

10. BALANCED AUDIO / AES / LTC Outputs

This 30-pin multi-way connector provides outputs of Analog Balanced Audio, AES Audio, and LTC. These are user configurable via DashBoard.

11. GPS Input with +5v DC Output to Power Antenna

This coaxial connector is used to connect a suitable GPS aerial in order to be able to Genlock the SRG-4400, and to provide accurate time and date information.

12. 1Hz Output

This BNC provides a 1Hz pulse.

13. 10MHz Input

This BNC allows the user to supply a 10MHz reference from an external device.

14. 10MHz Output

This BNC provides an output of 10MHz derived from either the extremely stable internal oscillator, or looped-through from the 10MHz IN. A relay controls which signal is routed to this output.

15. WK/TTL1, WK/TTL2, and 6Hz/TTL3 Outputs

These three BNCs each provide independent outputs of either Word Clock or 6Hz, or any one of a selection of traditional pulses, e.g. Mixed Sync, Mixed Blanking, etc.

16. DARS Output

This BNC provides an output of DARS (Digital Audio Reference Signal).

17. AES1 and AES2 Outputs

These two BNCs provide outputs of the associated AES audio channels in AES3id format.

Operating Basics

The SRG-4400 produces a wide variety of video and audio references and test pattern signals suitable for distribution within a typical television engineering installation.

The SRG-4400 can be configured in a number of ways:

- Free Run, or Genlock / Time-Lock to a selection of sources
- Configurable Video Outputs (Format, Ident, Timecode, Audio, etc.)
- Ethernet connectivity for software updates and logo uploads

For More Information on...

- the configuration parameters within entire menu system, refer to the chapter “**Menu System**” on page 5-1.

Rebooting the NTP or GPS Sub-system

Several tabs in DashBoard provide a reboot button that can be used to reset software modules of the SRG-4400. In specific:

- **Slot 0: SRG-4400 > Genlock > Do GPS Reboot** will reboot the SRG-4400 and reset the GPS receiver hardware and software communications (if the option is installed).
- **Slot 0: SRG-4400 > Genlock > Do NTP Reboot** and **Slot 16: System Setup > Network > NTP/PTP > Do NTP Reboot** will reboot the SRG-4400 and its network settings.

Software Upgrades

This upgrade procedure applies to SRG-4400 systems where an Ethernet connection is installed. It outlines the steps necessary to upgrade the software programmed on the main module.



Important — *Performing a software upgrade to the SRG-4400 requires the unit to be rebooted, and may be off-line for several minutes. Ensure that your system is not in use.*

Before You Begin

Before starting, ensure that you comply with the following requirements:

- Connect the SRG-4400 via an Ethernet cable to your local network.
- A PC, also connected via Ethernet to your local network, with the supplied update program(s) and associated data file(s) available. Ideally, data file(s) should be located in the same folder as the associated update program.



Important — *Do not re-name any of the files.*

- A power-cycle is required as part of a data file update.
- Ensure that you have the **RossSystemUpdate_Vx.x.x.x.exe** program. Contact Ross Technical Support for this program.

Uploading the Software Files

Table 4.1 lists the applicable files for your SRG-4400.

Table 4.1 SRG-4400 Files

File Type		Description
Bootware	Bootloader	At present, can only be uploaded at the factory.
Patfile	Pattern Files	Can be uploaded while the SRG-4400 is in operation. When complete, a power cycle is required.
Xilfile	FPGA File	Requires that the SRG-4400 is in Bootloader mode. When complete, a power cycle is required.
ArmFile	SRG-4400 Software	Requires that the SRG-4400 is in Bootloader mode. When complete, a power cycle is required.

Only newer files need to be loaded. Depending on the situation, an upgrade may consist of one of the following scenarios:

- Full upgrade — Requires the Pattern, FPGA file, and Software files
- Pattern File upgrade — Requires the Pattern files only
- Software upgrade — Requires the Software file only
- Firmware upgrade — Requires the Firmware file only

To prepare for the upgrade

1. Connect the SRG-4400 via an Ethernet cable to your local network.
2. Connect a Windows PC to the network, such that the SRG-4400 is visible.

3. Verify that the Ross System Update Tool and data files are in the same folder on the PC.

To upload software files to the SRG-4400

1. On your PC, launch the “RossSystemUpdate_v#. #. #. #. #. exe” program.
The **Ross System Update** dialog opens.

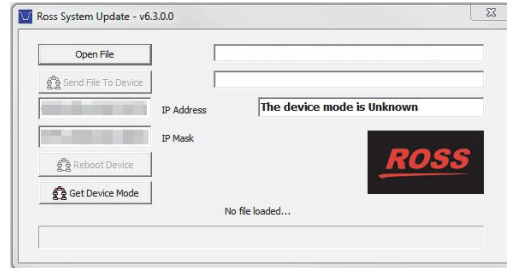

Ross System Update Dialog

2. Set the IP Address and IP Mask fields to the values for the SRG-4400 you want to upgrade. Note that all octets must be entered as 3-digits. For example, 255.0.0.0 should be entered as 255.000.000.000.
3. Click **Get Device Mode**.
The status field, located above the Ross logo, updates to display: “The device is in Application mode.”.
4. If the SRG-4400 is “not found”:
 - a) Check again that all connections have been made.
 - b) Verify that the IP Address and IP Mask values were entered correctly in step 2.
 - c) Power off the SRG-4400.
 - d) Repeat step 1. to step 3.
5. If the SRG-4400 still cannot be found, contact Ross Video for further assistance.
6. There are 3 files that consist of a full upgrade. Only newer files than those on the unit need be installed. The order they should be installed is as follows:
 - a) Pattern File (PatFile_XXXXX.ata)
 - b) FPGA File (XilFile_XXXX.ata)
 - c) Software File (ArmFile_XXXX.ata)
7. For each file:
 - a) Click **Open File** to display the **Open File** dialog.
 - b) Select the relevant “*.ata” file.
 - c) Click **OK** to load the file into the Ross System Update Tool and close the **Open File** dialog.
 - d) Click **Send to Device**.
 - e) If this is the first file to be uploaded, you will be asked to confirm the upload.
8. Monitor the upload:
 - a) The software will put the SRG-4400 into Bootload mode.
 - b) The Ross System Update Tool erases the old SRG-4400 file.
 - c) The Ross System Update Tool uploads the new file to the SRG-4400. Upload of a file takes approximately 1 minute.

- d) The status messages field in the **Ross System Update** dialog confirms that the upload was completed successfully.
 - e) If the upload was not successful, click **Send to Device** again and monitor the process.
- 9.** Once all files have been uploaded successfully, power-cycle the SRG-4400.
- 10.** Verify the software version of the SRG-4400 in DashBoard as follows:
- a) Launch the DashBoard client software on your PC.
 - b) Locate the SRG-4400 in the Basic Tree View in DashBoard.
 - c) Expand the **SRG-4400** main node in the tree view.
 - d) Double-click the **Slot 0: SRG-4400** sub-node.
 - e) Select the **System Report** tab.
 - f) Verify the values in the provided fields match the file(s) you uploaded.

Your SRG-4400 is now upgraded and ready for use.

Menu System

In This Chapter

The SRG-4400 provides the user with a menu interface on the chassis to control the functions and options of the instrument.

The following topics are discussed:

- Menu Screens and Maps
- Audio Menus
- Video Menus
- Timecode Menus
- Additional Information for the Summer/Winter DST
- Additional Information for the Leap Second Event (UTC)
- Genlock Menus
- System Setup Menus
- Configuration Menu
- Network Menu
- NTP Menus
- DashBoard Menu
- Backup Device Menu
- Option Enable Menu
- Calibration Menu

Menu Screens and Maps

The menus can always be viewed on the front panel LCD display, and optionally “in-vision” in an “on-screen-display” (OSD) viewable on any pattern output. By default, the **OSD** is set **On** for each pattern output, but can be independently disabled if desired.

The menus are accessed from the initial start-up (Time) screen by pressing the rotary control. To return to the Time screen, press the blue escape/back button. If you repeatedly press the blue button, the LCD display will cycle between the display of time and the display of logo.



Time Screen

In this display of time, the additional status information is:

- Device Name
- GPS/NTP Status
- Current Date
- Current Time
- SRG-4400 IP Address (when connected)
- Lock Status
- Software version number



Logo Screen

In this display of logo, the additional information is:

- Time
- GPS/NTP Status
- Logo
- SRG-4400 IP Address (when connected)
- Lock Status
- Software version number

For both of these screens, the top and bottom lines are animated, cycling between the information detailed above.

Immediately after re-connection of the Ethernet cable, or a video reference, the respective line may appear momentarily as: “Ethernet...negotiating” or “Genlocking.....”

By pressing the rotary control from either of the above screens, you access the top level menu. This menu gives you access to the five key menus that are used to control and configure the SRG-4400:

1. Audio menu
2. Video menu
3. Timecode menu

4. Genlock menu
5. System Setup menu

When viewing the top-level menu screen on a picture monitor, flashing text in the top-right corner of the menu will indicate which video output you are actually connected to.

Full details outlining how to use the front panel controls to navigate and change entries in the menus are given in the chapter “**Operating Basics**” on page 4-1.

Figure 5.1 provides a quick reference of the menu system.

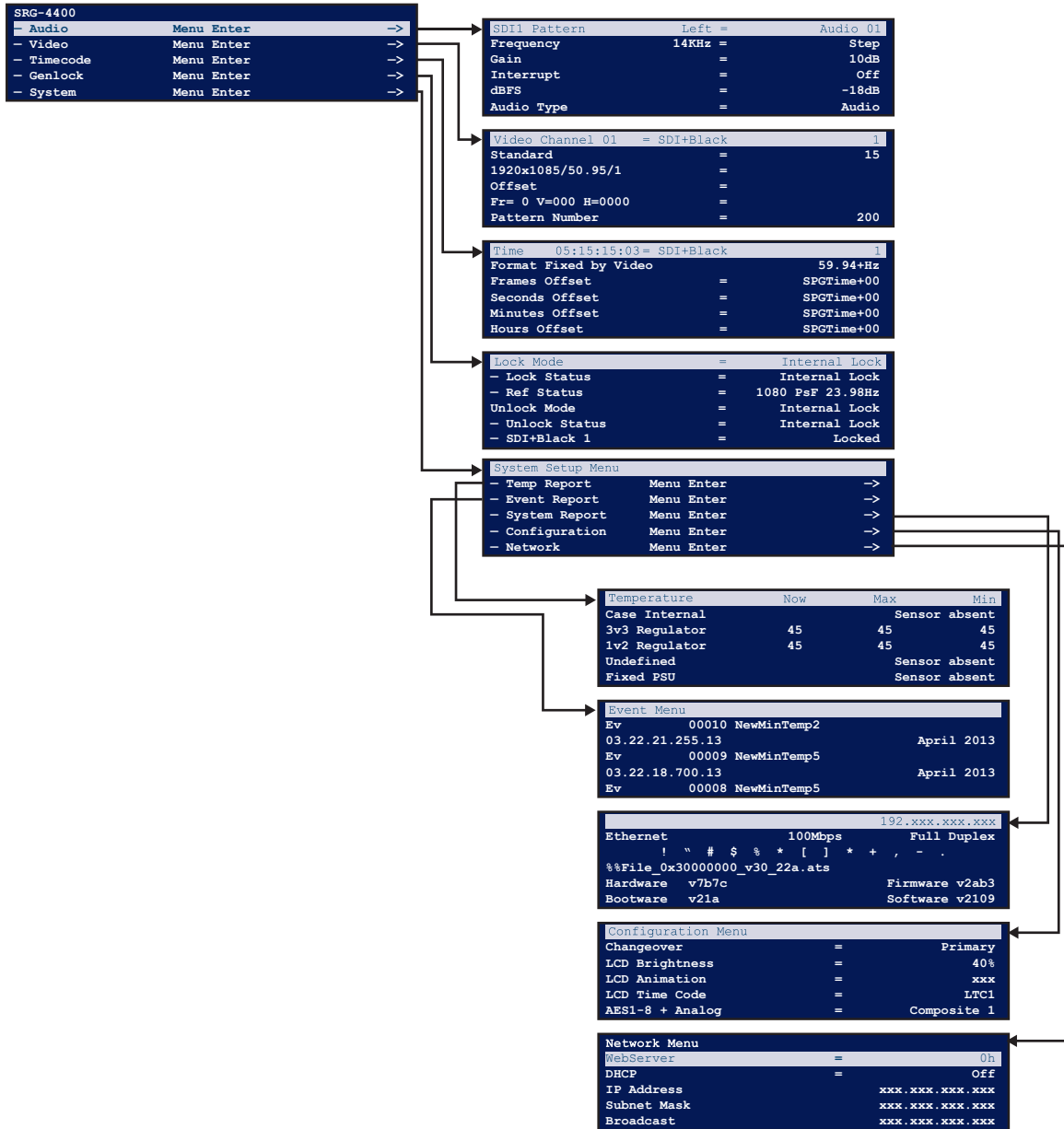

Figure 5.1 SRG-4400 — Menu Map (Pictorial)

Figure 5.2 is a basic menu tree structure of the SRG-4400. Note that there are 82 Audio Channel screens, 7 video channel screens, and 20 time screens.

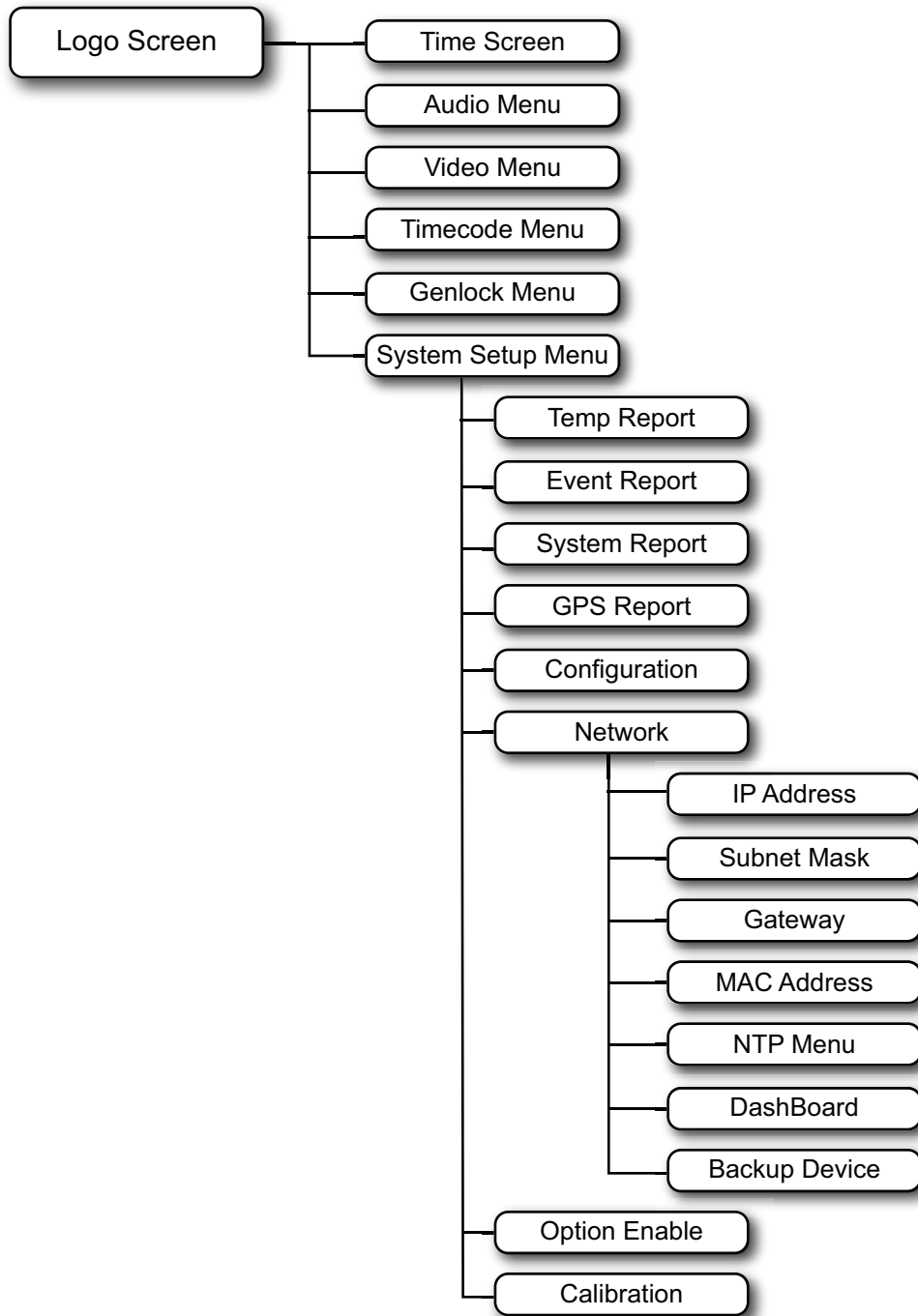

Figure 5.2 SRG-4400 — Menu Map (Diagrammatic)

Audio Menus

Each video output has audio channels associated with it:

- SDI 1 has 16 embedded audio channels
- SDI Black 1 has 16 embedded audio channels,
- SDI 2 has 16 embedded audio channels
- SDI Black 2 has 16 embedded audio channels,
- Composite 1 has 16 audio channels in 8 AES pairs
- Analog Audio has 2 audio channels in a stereo pair.

This makes a total of 82 audio channels.

Each channel can be individually controlled for frequency, gain, interrupt and dBFS.

Odd numbered channels 1, 3, 5, 7, 9, 11, 13 and 15 are referred to as LEFT.

Even numbered channels 2, 4, 6, 8, 10, 12, 14 and 16 are referred to as RIGHT.

In some circumstances, channels are grouped in pairs, or larger formations. When this occurs, associated menu selections are unavailable and 'menu information' is substituted:

- Glits groups channels in pairs.
- Blits groups the first 6 channels.

Table 5.1 outlines the general form of the Audio menu appears below for the SDI1, SDI2 and AES channels.

AudioChannel	=	Audio 01
Tone Type	=	400Hz
Spot Frequency	1KHz =	Step
Gain	=	-60dB
Interrupt	=	Off
dBFS	=	Silence
Audio Type	=	Audio
Sequence	=	Tone

Figure 5.3 Audio Menu Example

Audio Channel

This menu item allows the user to select which audio output they are operating on.

The **Audio Channel** field consists of three sub-fields. One item from each of the following columns will always appear in the three sub-fields, although not all combinations are valid.

Table 5.1 Audio Channel

Sub-field 1	Sub-field 2	Sub-field 3
SDI1	Pattern	Left
SDI2	Black	Right

Table 5.1 Audio Channel

Sub-field 1	Sub-field 2	Sub-field 3
Audio	AES1	Left Right
	AES2	
	AES3	
	AES4	
	AES5	
	AES6	
	AES7	
	AES8	
	Analog1	

SDI1 and SDI2 will only ever be followed by Pattern or Black, and Audio will only ever be followed by AES1 through AES8, or Analog1. All combinations will be followed by either Left or Right.

The options in the field are: 01 through 02 or 16 (depending on the selected Audio Channel).

Some examples from the complete list are shown below:

SDI1 Pattern ➤ Left = Audio 01

SDI1 Pattern ➤ Right = Audio 02

:

SDI1 Black ➤ Left = Audio 05

SDI1 Black ➤ Right = Audio 06

:

Audio AES6 ➤ Left = Audio 11

Audio AES6 ➤ Right = Audio 12

:

Audio Analog1 ➤ Left = Audio 01

Audio Analog1 ➤ Right = Audio 02

Tone Type

The options in the field are:

- 400Hz
- 800Hz
- 1KHz
- Sweep
- Step
- A-Maj Chord
- A-Maj Scale
- Spot Frequency

Sweep ramps the frequency from 20Hz to 20KHz in 3 seconds.

Step includes spot tones of:

- 400Hz
- 4KHz
- 9KHz
- 14KHz
- 800Hz
- 5KHz
- 10KHz
- 15KHz
- 1KHz
- 6KHz
- 11KHz
- 16KHz
- 2KHz
- 7KHz
- 12KHz
- 3KHz
- 8KHz
- 13KHz

A-Maj Chord uses the first 8 channels and includes the frequencies (from the Equi- Tempered Scale):

- 329.628Hz = E
- 880.000Hz = A
- 440.000Hz = A
- 1108.552Hz = C#
- 554.276Hz = C#
- 1318.512Hz = E
- 659.256Hz = E
- 1760.000Hz = A

A-Maj Scale is similar to Step but uses only the notes from the C-Major chord (from the Harmonic Scale):

- 1056Hz = C
- 1584Hz = G
- 1187Hz = D
- 1760Hz = A
- 1319Hz = E
- 1979Hz = B
- 1407Hz = F
- 2112Hz = C

Spot Frequency

Allows the user to select any frequency between 20Hz and 20KHz (in 1Hz steps).

Gain

The options in the field are: Silence, -60dB to +18dB (in 1dB steps). The upper limit is actually set by the dBFS menu (detailed below).

Interrupt

The options in the field are: Off, 1 sec, 3 sec, Glits, and Blits.

- Glits can only be selected on odd (left) channels. Glits also uses the associated even (right) channel in the pair to create a stereo audio identification sequence.
- Blits can only be selected on channel 01. Blits also uses the next five channels to create a 5.1 Surround Sound Audio Identification sequence.

dBFS

The options in the field are: Silence, -24dB to -18dB (in 2dB steps).

Audio Type

The options in the field are: Audio, Silence.

Sequence

The options in the field are: Tone.

Video Menus

This section outlines the options available in the Video menus for SDI1, SDI2, Composite 1, Black 1, and Tri-Black 2-4.

Table 5.2 Video Menus

Parameter	SDI1, SDI2		Composite 1	Black 1	Tri-Black 2, 3, 4	
	SD-SDI	HD-SDI			PAL/NTSC	Tri Black
Video Channel nn	xx		xx	xx	xx	
Standard	nn		nn	Same as Composite1	nn	
Description	
Offset	0000000 00.00u	0000000 00.000000	0000000 00.00u 000.0°	0000000 00.00u 000.0°	0000000 00.00u 000.0°	0000000 00.000000
	V=0000 H=0000		Fr=0 V=0000 H=0000 Sc=0000	Fr=0 V=0000 H=0000 Sc=0000	Fr=0 V=0000 H=0000 Sc=0000	V=0000 H=0000
Pattern Number	nnn		nnn			
Description			
ID Memory	n		n			
Character	n/mm = yyy		n/mm = yyy			
Description			
ID Vertical Pos	nnnn		nnnn			
ID Char Size	n		n			
ID Visible Rows	n		n			
ID Black Edge	Off		Off			
ID Off/Opacity	nnn%		nnn%			
ID Row Motion	Static		Static			
ID Box Motion	Static		Static			
Pattern Bounce	Off		Off			
Pattern Output	Pattern					
Black Output	Black					
Circle Type	Off		Off			
Circle Size	nnn		nnn			
Circle Aspect	16:9		16:9			
OSD Time & Date	xx					
Pattern OSD	On					
Black OSD	Off					
Number of OSD Rows	6		6			
OSDEvent Warning	Off		Off			

Table 5.2 Video Menus

Parameter	SDI1, SDI2		Composite 1	Black 1	Tri-Black 2, 3, 4	
	SD-SDI	HD-SDI			PAL/NTSC	Tri Black
Pattern Embedder	Off					
Black Embedder	Off					
Pattern ToneSil	Tone					
Black ToneSil	Tone					
Pattern VITC ^a	Off					
Black VITC ^a	Off					
Pattern EDH ^b	On					
Black EDH ^b	On					
VITC			Off			
Pattern F1L7			On #			
S318M ^c			On			
Black VITC				Off	Off	Off ^d
Black F1L7				On #	On #	On # ^d
Black S318M ^c				On	On	On

- a. ATC in HD formats.
- b. CRC in HD formats.
- c. This row only for NTSC.
- d. This row only for NTSC or PAL.

Menu Descriptions

Video Channel 01	= SDI+Black	1
Standard	=	05
720x 525/59.94/i NTSC-M	=	
Offset 0000000 00.00u 000.00°		
V=000 H=0000		
Pattern Number	=	5
ID Memory	=	1

Figure 5.4 Video Menu Example

Video Channel

This menu item allows the user to select the video output they are operating on. The options are:

- SDI+Black 1 for SDI 1 and SDI Black 1 outputs
- SDI+Black 2 for SDI 2 and SDI Black 2 outputs
- Composite 1 for Composite 1 output
- Black 1 for Black 1 output
- Tri Black 2 for Tri-Black 2 output
- Tri Black 3 for Tri-Black 3 output
- Tri Black 4 for Tri-Black 4 output

The options that appear in the next field follow the selection made above, and are:

- 01 for SDI 1 and SDI Black 1 outputs
- 02 for SDI 2 and SDI Black 2 outputs
- 05 for Composite 1 output
- 07 for Black 1 output
- 08 for Tri-Black 2 output
- 09 for Tri-Black 3 output
- 10 for Tri-Black 4 output

Standard, Description

This menu pair allows the user to select the video format for the video output they are operating on. The options in the field are:

- 05 through 36 for SDI 1 and SDI Black 1 outputs
- 05 through 36 for SDI 2 and SDI Black 2 outputs
- 04 through 06 for Composite 1 output
- Same as Composite 1 for Black 1 output
- 00 through 36 for Tri-Black 2, 3, and 4 outputs

Each of the 6 pattern generators is independent in format and pattern. For example, SDI 1 can be outputting 1080i 60Hz while SDI 2 is outputting 720p 24Hz and Composite 1 is outputting NTSC-M. Black 1 will also be outputting NTSC-M Color Black because it always mirrors the Composite 1 output format. Each of the three Tri-Black outputs can be simultaneously outputting formats differing again from those on the pattern outputs. So, the SRG-4400 could be configured to provide up to a total of 6 different output formats simultaneously.

The number selected (nn) is decoded into a description as outlined in **Table 5.3**.

Table 5.3 Decoded Descriptions

nn=	Description =	nn=	Description =
00	10MHz Sinewave # ^a	21	1920x1080/23.98/p
01	SLOW PAL 720x 625/48/i	22	1920x1080/60/i
02	NTSC Subcarrier 3.58MHz	23	1920x1080/59.94/i
03	PAL Subcarrier 4.43MHz	24	1920x1080/50/i
04	720x 525/59.94/i NTSC-J	25	1920x1080/48/i
05	720x 525/59.94/i NTSC-M	26	1920x1080/47.95/i
06	720x 625/50/i PAL	27	1920x1080/30/psf
07	1280x720/60/p	28	1920x1080/29.97/psf
08	1280x720/59.94/p	29	1920x1080/25/psf
09	1280x720/50/p	30	1920x1080/24/psf
10	1280x720/30/p	31	1920x1080/23.98/psf
11	1280x720/29.97/p	32	1920x1080/60/p
12	1280x720/25/p	33	1920x1080/59.94/p
13	1280x720/24/p	34	1920x1080/50/p
14	1280x720/23.98/p	35	1920x1080/48/p
15	1920x1035/60/i	36	1920x1080/47.95/p

Table 5.3 Decoded Descriptions

nn=	Description =	nn=	Description =
16	1920x1035/59.94/i	21	1920x1080/23.98/p
17	1920x1080/30/p	22	1920x1080/60/i
18	1920x1080/29.97/p	23	1920x1080/59.94/i
19	1920x1080/25/p	24	1920x1080/50/i
20	1920x1080/24/p		

a. # is Standard 00 on the Timeable Black outputs is currently disabled.

Offset, Description

For SD SDI channels, the Offset is represented as: 0000000 00.00µ 000.00°, V = 0000, H =0000.

For Composite 1, Black 1, and Tri-Black channels, the Offset is represented as: 0000000 00.00µ 000.00°, Fr = 0, V = 0000, H = 0000, Sc = 000.

This menu pair allows the user to select the timing offset from the SPG reference datum for the video output they are operating on. The timing offset is defined in two rows which are intimately linked. Either menu line can be edited - each menu line reflects changes in the other line. A brief description of the timing offset calculations is given here.

In the top line; the timing offset is a number of pixels delayed from the SPG reference datum. Where displayed, the offset is also decoded, for information only, as an H offset (in microseconds) and SC offset (in degrees).

In the top line, the timing offset is editable and is represented as a “large number”:

e.g. 0-2474999 for Standard = 28
 Description = 1920x1080/59.94/i

e.g. 0-726404095 for Standard = 05
 Description = 720x525/59.94/i NTSC-M

This “large number” will vary depending on the selected format.

In the bottom line, the timing offset is decoded into picture offsets expressed as:

Frame offset Fr=0
 where Fr=0-1 or 0-3 depending on the selected video format

Line offset V=0000
 where V=0 up to the total number of video lines in the selected format

Pixel offset H=0000
 where H=0 up to the total number of video pixels in each line of the selected format

Sub-carrier offset Sc=0000
 where Sc=0 up to the total number of sub-pixels that equate to one cycle of sub-carrier in the selected format

Frame and Sub-carrier offsets only appear when PAL or NTSC is selected on Composite 1, Black 1 and the Tri-black outputs.

Each of these fields is editable. Together with the timing offset in the top row, these fields enable the user to apply offsets rapidly to individual video outputs.

Pattern Number

This menu pair allows the user to select the pattern for the video output they are operating on. The options in the field are 0 up to the maximum number of patterns allowed for the output being configured.

Patterns are selectable on: SDI 1 output, SDI 2 output, and Composite 1 output.

Additionally, patterns may also be selected to appear on the SDI Black outputs (same pattern as selected on the associated Pattern outputs).

All other outputs normally produce only Black.

Each pattern generator is independent in both format and pattern. So, for instance, SDI 1 can be outputting a RP219 bars in 1080i 60Hz while SDI 2 is outputting Pathological Test in 720p 24Hz and Composite 1 is outputting SMPTE bars in NTSC-M.

The list of available patterns in each format can be different. Some patterns are format specific, and so do not appear in the list for other formats, e.g. the SDI specific Pathological test pattern does not appear in the list for an analogue NTSC output.

Pattern descriptions are as detailed as possible within the limitation of 30 characters.

The list of patterns is constantly changing as we add more patterns to the Pattern Library. These new patterns can be uploaded to your SRG-4400 over the Ethernet interface. You will need to find some maintenance time to do this as a power cycle may be required

ID Memory, Character, Description

This menu triplet allows the user to select and edit the ID Text/Image for the video output they are operating on.

ID Text/Image is selectable on: SDI 1 output, SDI 2 output, and Composite 1 output. Each of the three outputs has a separate set of ID Text/Image memories. When the ID Memory is selected to be ordinary text, the options in the field are 1 through 3. These are ID text memories. Each memory is edited individually. This field selects which memory is 'active' and hence enabled and editable in the menu. When "n" is selected in the ID Memory line, "n" in the Character line follows.

The options in the next field are: 01 through 30. There are a maximum of 30 characters in each ID text memory. This field selects which character is 'active' and hence editable in the menu. In the selected "Description" line, as this field is changed, a cursor gives a visual indication of which character is active.

The options in the third field are: 000 through 255. There are 256 characters in the extended ASCII font. Each ID character is edited individually. This field is adjusted to display the required character in the selected ID Text memory.

Not all the characters 000 through 255 are allowed. The ones that are not allowed are automatically skipped.

Notes:

- After adjusting the field "yyy", use the Escape/Back button to select the next character to edit, then press Select to edit the next character, etc.
- When using the available front panel controls, editing of the characters in ID text memories is performed in Overtyping mode (e.g. it is not possible to Insert or Delete characters).

- When you edit the pre-programmed ID Text memories, start from character position 1, then overtype with spaces (char. #32) any extraneous characters at the end of the line.
- To quickly edit ID text memories, use the DashBoard interface. Refer to the chapter “Connecting via Dashboard” on page 12-1 for more details.

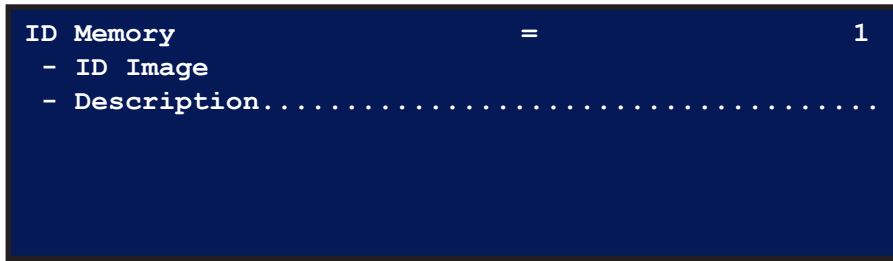

Figure 5.5 ID Memory is Selected

When the ID Memory is selected to be an ID Image, the options in the field are: 4 through 64. These are ID Image memories. Each memory is edited individually. This selects which memory is 'active' and hence enabled in the menu.

Each memory contains an imported 3bit bitmap image. Details regarding the format of the bitmap image and how to import images can be found in the appendices.

Additional image specific menu items appear when the ID Image option is active:

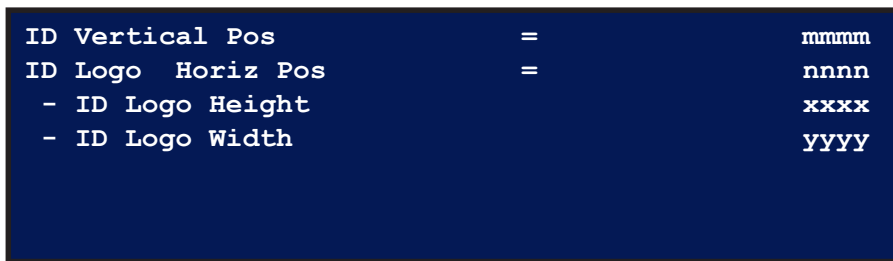

Figure 5.6 Active ID Logo Option

The options in the field “mmmm” are from 0000 up to a value less than the number of vertical lines in the currently selected video format.

The options in the field “nnnn” are from 0000 up to a value less than the number of horizontal pixels in the currently selected video format.

The fields “xxxx” and “yyyy” display numbers relating to the height and width of the imported image. These numbers are fixed during the import process and are not adjustable in this menu.

ID Vertical Position

This menu item allows the user to select the vertical position of the ID Text box for the video output they are operating on. This setting is valid for static ID Text boxes, and may be restricted for animated ID Text boxes.

The options in the field are: the TV line on which the top of the ID Text box sits. The field is a value less than the number of lines in the prevailing video format.

When adjusting this value, other parameters relating to the ID Text box may restrict this range, or may be re-calculated, in order to keep the ID Text box visible within the picture area.

ID Character Size

This menu item allows the user to select the size of the text in the ID Text box for the video output they are operating on.

The options in the field are: 1 through 7. This value is a representation of the size of the font in use.

When adjusting this value, other parameters relating to the ID Text box may restrict this range, or may be re-calculated, in order to keep the ID Text box visible within the picture area.

ID Visible Characters

This menu item allows the user to select the number of characters that are visible in all rows of the selected ID Text box for the video output they are operating on.

The options in the field are: 0 through 30, and Automatic.

The maximum number of characters allowed per row depends on the video format selected on the associated output. For example, the 1920x1080/50/i format is allowed 30 characters, while all the 1280x720 formats, plus PAL and NTSC formats are only allowed 26.

This can be set to create a 'text box' of any width cutting a hole in the video. The number of characters in the ID and the number of "ID Visible Chars" do not have to be the same. The displayed characters are always centered in the row on a pixel basis. When this field is adjusted, automatic re-centering occurs to best position the text within the ID Text box.

When set to Auto, the ID Text box width is handled automatically so as to include all of the characters of the longest ID line to be displayed (up to the maximum allowed for the selected format).

When adjusting this value, other parameters relating to the ID Text box may restrict this range, or may be re-calculated, in order to keep the ID Text box visible within the picture area.

ID Visible Rows

This menu item allows the user to select the rows of ID Text that are to be visible in the ID Text box for the video output they are operating on.

The options in the field are: 1, 2, 3, 1 & 2, 2 & 3, 3 & 1, and 1 & 2 & 3.

This can be set to create a text box of any height, cutting a hole in the video. The number of user-programmed ID rows and the number of "ID Visible Rows" do not have to be the same.

When adjusting this value, other parameters relating to the ID Text box may restrict the options, or may be re-calculated, in order to keep the ID Text box visible within the picture area.

ID Black Edge

This menu item allows the user to control the border around the text box. This option is currently non-functional.

ID Off/Opacity

This menu item allows the user to control the opacity of the background of the ID Text box or the ID Image for the video output they are operating in.

The Opacity in the field can be selected to be: 0 (ID off completely) through 100 (white text on a black background) in 16 steps, Animated. The Animated mode can be useful to indicate the video is 'live'.



Note — *When Black is selected as the pattern on the video pattern output, the Animated mode is inhibited (e.g. to reduce APL effects).*

ID Row Motion

This menu item allows the user to control the animation of the text rows within the ID text box for the video output they are operating on. These animated modes can be useful to indicate the video is 'live'. When selecting these modes, other ID Text parameters may restrict what is visible within the ID Text box.

Table 5.4 ID Row Animation Modes

Mode	Description
Static	Text row(s) motionless
Flash	Text row(s) flash on and off
Sequence	Text row(s) appear in sequence when set for 1 or 2 visible rows
Roll	Text row(s) roll continuously from the bottom of the box to the top
Reveal	Text row(s) are revealed downwards using a “vertical wipe”
Zip	Text row(s) are revealed in row order, character-by-character

ID Box Motion

This menu item allows the user to control the animation of the entire ID Text box or ID image for the video output they are operating on. These animation modes can be useful to indicate the video is 'live'. The ID Box Motion extents in animation modes may be limited by one or more other menu or ID settings.

Several box animation modes are available:

Table 5.5 ID Box Animation Modes

Mode	Description
Static	Text/Image box is motionless
Horizontal	Text/Image box bounces from side-to-side
Vertical	Text/Image box bounces up and down
Elliptical	Text/Image box moves in an elliptical motion
Box	Text/Image box describes a rectangle
Cross	Text/Image box moves in a “bow-tie” motion
Pong	Text/Image box moves in a pseudo-random motion

Pattern Bounce

This menu item allows the user to control the Bounce animation on applicable patterns. Not all patterns bounce. Bounce is a useful test as it dynamically changes the average picture level (APL) of the pattern. This can be used to help diagnose errors in downstream video equipment.

For the Composite 1 output, the menu line appears as: Bounce = On.

The options in the field are:

- Off — The Bounce function is disabled for the selected video output.
- On — The Bounce function is enabled for the selected video output.

Pattern Output

This menu item allows the user to control the SDI Pattern output. The SDI Pattern output can be selected to be: Black, Pattern, DualA, and DualB.

The user may require more SDI Black outputs than SDI Pattern outputs.

If DualA or DualB is selected, the output is configured to be the first half of a SDI Dual Link interface together with the SDI Black output (see below).

Black Output

This menu item allows the user to control the SDI Black output. The SDI Black output can be selected to be: Black, and Pattern.

The user may require more SDI Pattern outputs than SDI Black outputs.

When the associated SDI Pattern output is selected to be DualA or DualB, the SDI Black output is forced to be the second half of an SDI Dual Link interface together with that SDI Pattern output.

Circle Type

This menu item allows the user to enable the circle feature on the Pattern video output they are operating on.

For the Composite 1 output, the menu line appears as: Circle Type = Off.

The options in the field are: Off, Static, and Animated.

Animated circles are useful as a lip-sync test as the circle and audio are synchronized together. Animated circles are also useful for indicating the video is 'live'.

Circle Size

This menu item allows the user to control the size of the circle on the Pattern video output they are operating on.

For the Composite 1 output, the menu line appears as Circle Size = nnn.

The options for the field are 0 up to a maximum of 540. The maximum number is related to the selected video format. The maximum circle size is approximately half the number of visible lines in that video format, e.g. for NTSC, the maximum size = 245, PAL = 282, 720p = 362, 1080i = 551, etc.

Circle Aspect

This menu item allows the user to control the aspect ratio of the circle on the Pattern video output they are operating on.

For the Composite 1 output, the menu line appears as: Circle Aspect = 16:9.

The options in the field 16:9 are: 4:3 (for SD formats), 16:9 (for SD formats), Fixed (for HD formats only (fixed at 16:9)).

OSD Time & Date

This menu item allows the user to control the behavior of the 'on screen display' (OSD) when it is not being used for menus.

The options in the field are: Off, Time, Time-Date, and GPS.

When "on" and not in a menu, the selected information will appear cut into a text box on the relevant pattern output.

The Time being displayed is the timecode being output on the video channel you are looking at. Thus if you are looking at two screens to inspect SDI1 output and SDI2 output the time displays may be offset from each other.

There may be an extra character to the right of the frames-units number. This is a field/frame marker.

- In interlaced video formats, the top-left block appears in the first field, the bottom-right block appears in the second field.
- In progressive video formats at frame rates above 30Hz, the same timecode is output for each frame due to a limitation defined in *SMPTE-12M*. In these higher frame rates, the top-left block appears in the first frame of the pair, the bottom-right block appears in the second frame of the pair.
- In progressive video formats at frames rates at or below 30Hz, the field/frame marker is not displayed, as a unique timecode exists for each frame.

Pattern OSD, Black OSD

These menu items allow the user to enable the 'on screen display' (OSD) for the video output they are operating on.

For the Composite 1 video output, the menu line appears as: OSD = On.

The options in the field are:

- Off — The OSD does not appear on the selected video output.
- On — The OSD does appear on the selected video output.

Number of OSD Rows

This menu item allows the user to select the number of rows of text in the OSD menus. This is currently fixed at 6 rows.

Event Warnings

This menu item allows the user to control the behavior of the LCD when an event occurs. Events include: ethernet loss of cable, ethernet find cable, and maximum temperature limit reached.

The options in the field are:

- Off — No warning messages will pop-up on the LCD or on the video outputs.
- On — Warning messages will pop-up in the LCD and on the video outputs.

Pattern Embedder, Black Embedder

These menu items allow the user to control the channel allocation of the audio embedders on the SDI Pattern and SDI Black video output signals. The options are different in SD SDI and HD SDI.

The SD embedder can embed a maximum of 4 channels into the video signal. The options in the fields are: Off, Group 1, Group 2, Group 3, and Group 4.

The HD embedder can embed a maximum of 16 channels into the video signal. The options in the fields are: Off, Audio 1-4, Audio 1-8, Audio 1-12, and Audio 1-16.

Pattern ToneSil, Black ToneSil

These menu items allow the user to control the audio content of the audio embedders on the SDI Pattern and SDI Black video output signals. The options in the field are:

- Tone — Audio is embedded as configured in the associated Audio menus.
- Silence — Overrides any selections made in the associated Audio menus

Pattern VITC, Black VITC

These menu items allow the user to control the behavior of the timecode inserters on the SDI Pattern and SDI Black video output signals. The options are different in SD SDI and HD SDI.

The SD SDI inserter can insert VITC into appropriate lines in the SD SDI video. The options are different in NTSC and PAL (see *SMPTE 266M-2002*).

NTSC options in the field are: Off, On 14, On 14 and 16.

PAL options in the field are: Off, On 19, On 19 and 21.

The HD SDI inserter can embed ATC into the HD SDI video.

HD options in the field are: Off, LTC, and VITC.

Pattern EDH, Black EDH

These menu items allow the user to control whether EDH (Error Detection and Handling) data is included on the SD-SDI Pattern and SD-SDI Black video output signals.

The options in the field are:

- Off — No EDH data added to the SDI output.
- On — EDH data is added to the SDI output

Pattern CRC, Black CRC

These menu items allow the user to control whether CRC (Cyclic Redundancy Check) data is included on the HD-SDI Pattern and HD-SDI Black video output signals.

The options in the field are:

- Off — No CRC data added to the SDI output.
- On — CRC data is added to the SDI output.

VITC, Black VITC

These menu items allow the user to control the behavior of the timecode inserters on the Composite 1, Black 1 and Tri-Black video output signals.

The Composite, Black and Tri-Black inserters can insert VITC into appropriate lines in the video. The options are different in NTSC and PAL (see *SMPTE RP188-1999*).

NTSC options for the field are:

- Off
- 10 through 20 (one-line VITC)
- 10 & 12, 11 & 13, 12 & 14, through 18 & 20 (two-line VITC)

PAL options for the field are:

- Off
- 6 through 22 (one-line VITC)
- 6 & 8, 7 & 9, 8 & 10, through 20 & 22 (two-line VITC)

Pattern F1L7, Black F1L7

These menu items allow the user to control whether the F1L7 (Field 1 Line 7) or F1L10 (field 1 Line 10) ident signals appear on the Composite 1, Black 1 and Tri-Black video output signals. The F1L7 signal is defined for the PAL format, the F1L10 signal for NTSC.

The options in the field are:

- Off — F1L7 / F1L10 does not appear on the selected video output.
- On — F1L7 / F1L10 appears on the selected video output.

No S318M

This menu line appears on the Composite menu (NTSC version) to indicate that the S318M ident signal is not defined for this output.

Black S318M

This menu line allows the user to control whether the S318M ident signal appears on the Black 1 or Tri-Black video output signals. This signal is only defined for color black in the NTSC format (see *SMPTE 318M-1999*).

The options in the field are:

- Off — S318M does not appear on the selected video output.
- On — S318M appears on the selected video output.

Timecode Menus

Each Video output has a counting timecode channel associated with it:

- SDI and SDI Black 1 output
- SDI and SDI Black 2 output
- Composite 1 output
- Black 1 output
- Tri-Sync Black 2 output
- Tri-Sync Black 3 output
- Tri-Sync Black 4 output

There are 4 linear counting timecode (LTC) channels:

- LTC1
- LTC2
- LTC3
- LTC4

There are five more counting times that are important in the system. These are:

- SPG Time
- UTC Date Time
- GPS Date Time - extracted from the optional GPS receiver
- NTP Date Time - extracted from a suitable NTP timeserver via the Ethernet interface

There are three more non-counting times that are important in the system. These are:

- Summer DST Event
- Winter DST Event
- Leap Second Event

UTC Date Time is locked to one of Real Time Clock (RTC), GPS Date Time, NTP Date Time, or Analog Ref VITC.

SPG Time is locked to UTC Date Time. UTC Date Time is the datum from which SPG Time is offset. The central time to which all Video and LTC timecodes are locked is SPG Time. SPG Time is also the datum from which all Video and LTC timecodes are offset.

Summer DST Event, Winter DST Event and Leap Second Event each define times and dates at which TC-events occur.

The inter-relationships between the times and timecode is fixed. Only the offsets and TC-events affect the times for each timecode.

For More Information on...

- the timecode system workflow, refer to **Figure 1.5**.
- the procedure to initially set your local time and date parameters, refer to **Figure 5.14**.

Table 5.6 Timecode Menus

Parameter	Video	LTC	SPG Time	UTC Date & Time	GPS Date & Time	NTP Date & Time	Analog Ref VITC	Digital Ref TC	DST Event ^a
Description							
Format Fixed by Video	nnxx	nnxx							
Searching for GPS Solution					...				
NTP Client is Turned Off						...			
No NTP Time							
No AREF Time								...	
No DREF Time									
Action DateTime									
Running Time	hh:mm:ss:ff	hh:mm:ss:ff	hh:mm:ss:ff	hh:mm:ss:ff	hh:mm:ss:ff				hh:mm:ss:ff
Offset	SPGTime+0 0:00:00:00	SPGTime+0 0:00:00:00	UTC+00:00: 00:00						
Running Time				hh:mm:ss:ff					
Nudge				00:00:00:00					
Weekday				Date Month Year	Date Month Year	Date Month Year			Date Month Year
Leap Second				Off					
Daylight Saving				Off					
Country Code				nnn					
Description				...					
StateCode				nn					
Description				...					

a. Includes the Summer DST Event, Winter DST Event, and Leap Second Event menus.

Notes on the Timecode Menus

- Video Timecodes count at the frame-rate defined by the video format of the selected video channel.
- LTC Timecodes count at the frame-rate defined by the format selected in the menu. SPG Time and UTC DateTime are both “FIXED”, counting at 50Hz.
- Each LTC Timecode can be configured, in DashBoard, to report the **Date In User Bits**. Navigate to the Slot 12: System Time > LTC # Time tab for this menu.
- GPS DateTime and NTP DateTime are “FIXED”, being displayed at 50Hz - they only count if a GPS or NTP reference is present.
- Summer DST Event, Winter DST Event and Leap Second Event do not count.
- The system has a battery backed real-time-clock. This runs independently of any other reference. It can maintain reasonably accurate time over a few days while the unit is

powered down. It is NOT to be trusted as reliable where your application requires accurate time. As the GPS system is so inexpensive, we recommend its use in all vehicle installations where power may switch on and off regularly.

- Several menu lines are identical between menu screens. Where possible, to avoid obvious repetition, in the definitions outlined below, identical menu lines are grouped under one definition.

Menu Examples

```

Time      05:15:15:03      = SDI+Black      1
Format Fixed by Video     =          59.94+Hz
Running Time              =          hh:mm:ss:ff
Offset                   = SPGTime+00:00:00:00
  
```

Figure 5.7 Time Menu Example — All Video Timecodes

```

Time      05:15:15:03      = SDI+Black      1
Format                    =          59.94+Hz
Running Time              =          hh:mm:ss:ff
Offset                   = SPGTime+00:00:00:00
  
```

Figure 5.8 Time Menu Example — All LTC Timecodes

```

SPG Time
Running Time              =          hh:mm:ss:ff
Offset                   =          UTC+00:00:00:00
  
```

Figure 5.9 Time Menu Example — SPG Time

```

UTC DateTime
Running Time              =          hh:mm:ss:ff
Nudge                    =          00:00:00:00
Weekday   Date          Month   Year
Leap Second              =          Off
Daylight Saving          =          Off
  
```

Figure 5.10 Time Menu Example — All UTC Date & Time

```

GPS DateTime (UTC)
GPS Solution found:
Running Time (UTC)          =          hh:mm:ss:ff
SVs in View = XX          in Fix = xx
Weekday   Date      Month   Year
xLocked to GPS

```

Figure 5.11 Time Menu Example — GPS Date & Time (When Enabled)

Menu Descriptions

This section provides a summary of the options available in each field of the Time menu.

Description

The options that appear in this line are:

Table 5.7 Description Field Options

Option	Description
SDI1 & SDI2Black1 Timecode	For SDI and SDI Black 1 output
SDI2 & SDI2Black1 Timecode	For SDI and SDI Black 2 output
Composite 1 Timecode	For Composite 1 output
Black 1 Timecode	For Black 1 output
Tri-Sync Black2 Timecode	For Tri-Black2 output
Tri-Sync Black3 Timecode	For Tri-Black3 output
Tri-Sync Black4 Timecode	For Tri-Black4 output
LTC 1 Timecode	For LTC1 output
LTC 2 Timecode	For LTC2 output
LTC 3 Timecode	For LTC3 output
LTC 4 Timecode	For LTC4 output
SPG Time	For SPG time
UTC DateTime	For UTC date and time
GPS DateTime (UTC)	For GPS date and time
NTP DateTime (UTC)	For NTP date and time
Analog Ref VITC (UTC)	For analog reference VITC time
Digital Ref VITC (UTC)	For digital reference timecode time
Sumer DST Event (UTC)	For summer Daylight Saving Time event date and time
Winter DST Event (UTC)	For winter Daylight Saving Time event date and time
Leap Second Event (UTC)	For Leap second event date and time
Jam Event (SPG)	for Jam Event Time

The menu line `UTC DateTime (manual)` indicates that UTC Time and date parameters are manually adjustable. When either GPS or NTP are enabled and locked, this menu line changes to

reflect the status of the external time reference source, and will appear as either: UTC DateTime from GPS or UTC DateTime from NTP.

Format Fixed by Video

The options in the field “nnx” for the Video channels are defined by the Video format of the selected Video channel. These options are for information only, and cannot be changed in this menu. Sub-field “nn” describes the frame rate, and “x” describes the scanning system:

e.g. Format Fixed by Video 50i

e.g. Format Fixed by Video 23.98p

Format

This menu item allows the user to select the required format for the LTC output they are operating on.

The options in the field for the LTC channels are limited to: 30p, 29.97p, 25p, 24p and 23.98p where field describes the frame rate, and the scanning system.

Running Time

This menu item displays the current time on the selected Video Output or LTC Timecode channel, or the SPG Time or UTC DateTime menus. This time display includes any offset that has already been entered for that channel.

The field “hh:mm:ss:ff” displays hours, minutes, seconds and frames in the 24-hour format.

Where the Running Time relates to a Video Output or an LTC Timecode channel, the separators between the sub-fields change, depending on the format selection:

Separator	Format
“;”	All 59.94, 47.95, and 29.97 frame rates
“:”	All other frame rates

Offset = SPGTime + 00:00:00:00

This menu item allows the user to offset the time on the selected Video or LTC Timecode channel with respect to SPG Time.

The field “00:00:00:00” is used to add / subtract time to / from SPG Time in the selected Video or LTC Timecode channel. The sub-fields in the field “00:00:00:00” represent hours: minutes: seconds: frames. When sub-fields are adjusted, the corresponding fields in “Running Time” reflect the changes.

Each sub-field is edited individually. A highlight cursor is displayed showing which sub-field is active and hence editable in the field.

These sub-fields always display any offset that has been entered by the user.

If the offset time is zero or positive, a plus sign is displayed (as above); if the offset time is negative, a minus sign is displayed.

Offset = UTC + 00:00:00:00

This menu item allows the user to offset SPG Time with respect to UTC Time.

This is where the user should enter their current time-zone offset from UTC. This offset should not include any daylight saving offset that may be in force - Daylight Saving adjustments are handled separately (see below).

The field “00:00:00:00” is used to add / subtract time to / from UTC Time in the SPG Time menu. The sub-fields in the field “00:00:00:00” represent hours: minutes: seconds: frames. When sub-fields are adjusted, the corresponding fields in “Running Time” reflect the changes.

Only the “hours” and “minutes” sub-fields are editable. A highlight cursor is displayed showing which sub-field is active and hence editable in the field. The “hours” sub-field is fully adjustable from -12 to +12. The “minutes” sub-field is only adjustable in 15 minute intervals - this is because the smallest defined increment in the list of global time-zones is 15 minutes.

These sub-fields always display any offset that has been entered by the user.

If the offset time is zero or positive, a plus sign is displayed (as above); if the offset time is negative, a minus sign is displayed.

Running Time (UTC)

This menu item displays the current time, as received by the GPS system, on the GPS Date Time (UTC) menu. This time only displays when a GPS solution has been found, and the system is locked to the received data.

The field hh:mm:ss:ff displays hours, minutes, seconds and frames in the 24-hour format. Note that frames are always displayed as 00, because this information is not included in the GPS data stream.

Nudge

This menu item allows the user to manually adjust UTC Time (where the SPG is not synchronized to an external time source, such as GPS or NTP, i.e. when neither option is enabled in the Option Enable menu).

The field “00:00:00:00” is used to add / subtract time in the UTC DateTime menu. The sub- fields in the field “00:00:00:00” represent hours: minutes: seconds: frames. When sub- fields are adjusted, the corresponding fields in “Running Time” reflect the changes.

Each sub-field (except “frames”) is edited individually. A highlight cursor is displayed showing which sub-field is active and hence editable in the field.

UTC time counts continuously. Note that each time the seconds field is nudged, the frames field is reset to zero. This provides an easy way to set the UTC time to be coincident with your temporary reference.

This field always displays zeros in each of the sub-fields.

When GPS or NTP are enabled, the Nudge feature is disabled, and this menu line appears as either:

Fixed by GPS = 00:00:00:00

or

Fixed by NTP = 00:00:00:00

Weekday Date Month Year

This menu item allows the user to set or adjust the date parameters for the UTC DateTime menu (where the SPG is not synchronized to an external time source, such as GPS or NTP, i.e. when neither option is enabled in the Option Enable menu), or for the Summer DST Event, Winter DST Event or Leap Second Event menus (when in User Defined mode).

The Weekday field is not adjustable. It is calculated using the settings in the Date, Month, and Year fields. The options in the Weekday field appear as: Monday through Sunday.

The options for the Date field are: 1 through 28, 29,30 or 31 according to the setting of the “Month” field.

The options for the Month field are: January through December.

The options for the Year field are:

- 2000 through 2034 for the Summer DST, Winter DST and Leap Second menus
- 2007 through 2034 for the UTC DateTime menu

Note these dates may already have been pre-set using the Daylight Saving and Leap Second menu options detailed below.

Leap Second

The options in this menu line are: Off, User Defined.

If set to “User Defined”, then the time and date will automatically adjust at the time and date set in the Leap Second Event (UTC) menu.

If the menu line “Leap Second” is set to “Auto from GPS”, the time and date of the event is automatically determined via the GPS connection.

Action DateTime

This menu item allows the user to set or adjust the time at which a Summer DST Event, a Winter DST Event, or a Leap Second Event occurs.

The field “hh:mm:ss:ff” is used to set the time at which the event happens. The sub-fields in the field “hh:mm:ss:ff” represent hours: minutes: seconds: frames. Sub-fields are adjusted directly, and automatically reflect any changes.

For these menus, only the “hours” sub-field is adjustable. A highlight cursor is displayed showing which sub-field is active and hence editable in the field.

Note these times may already have been pre-set using the Daylight Saving and Leap Second menu options detailed below.

Daylight Saving

The Daylight Saving mode should be selected only after setting the required Country Code. The options in this field are:

- Off — No Daylight Saving services are provided by the SRG-4400.
- User Defined — A single spring and autumn daylight saving service is provided.
- Automatic — If the country code is set to Australia, Brazil, Canada, New Zealand, USA or any European country, then a full daylight saving service is provided over a sequence of years up to 2034. This option is only enabled when Country Code is set for a DST supported country.

If set to User Defined, then the Video and LTC menu times will automatically adjust at the times and dates set in the Summer DST Event and Winter DST Event menus. Once a spring event is completed, the year of the programmed event is changed to 2035 so that it will never repeat. Once the autumn event is completed, the year of the programmed event is changed to 2035 so that it will never repeat, and the Daylight Saving mode is also set to Off. To program the next pair of events, set the mode to User Defined, and then enter the next pair of times and dates in the Summer DST Event and Winter DST Event menus.

When this field is set to Automatic, the Summer DST Event and Winter DST Event menus are immediately updated to be ready for the next two events based on the current time and date, and the previously configured Country Code.

While set to Automatic, as each DST Event occurs, it is updated to be ready for the following year.

Countries not supported in Automatic mode should implement DST on a year by year basis using semi-automatic support, i.e. using the User Defined mode above.

The fully- and semi-automated DST support requires the operator to enter location information. A Country Code is mandatory to correctly index the required DST information. For Australia, Brazil, Canada and United States of America, you will also be required to enter a State Code, as different states may or may not implement DST.



Note — *Whenever the Country Code field is adjusted, the Daylight Saving mode always defaults back to User Defined. The user then decides whether to implement daylight saving automatically, or to enter dates and times manually.*

Even if you don't implement DST, it is still useful to enter your country code, as this informs the SRG-4400 of its location in either the Northern or Southern hemisphere. The menus adjust to the location information. The Country Code and State Code definitions are detailed below.

Country Code, Description

This menu item allows the user to adjust the Country Code to suit the actual location of the SRG-4400. This should be adjusted before selecting the Daylight Saving mode.

The options for the Country Code are from **ISO 3166-1 Numeric Code**.

The description field displays the ISO 3166-1 English short name.

If you select Daylight Saving to Automatic after setting Country Code = nnn (where nnn is a country code that has automatic DST support), then the summer and winter times and dates will be automatically updated in the DST menus.

The SRG-4400 does NOT support this automatic filling of the times and dates for all country codes.

If the selected Country has multiple states that are defined to have differing Daylight Saving criteria, and the SRG-4400 has support for these countries, then the menu items in the following paragraph become available.

StateCode, Description

This menu pair allows the user to set the geographical State Code of the SRG-4400, but they only appear in the menu when the preceding menu option regarding Country Code is set for a country that has multiple states defined as having differing Daylight Saving criteria.

Some countries span more than one time zone, and in these countries, state codes are useful in defining summer daylight saving time behavior.

The options in the field for the state code are from **ISO 3166-2**.

The description field displays the ISO 3166-2 Subdivision name.

GPS DateTime (UTC)

The menu for GPS DateTime (UTC) is for information only - there are no editable fields. When a GPS solution has been found, the current time and date are displayed as received from GPS. G

If the GPS option is enabled, the menu reports whether a solution is being searched for.

When a GPS solution has been found, the last line changes to report that the GPS system is actively locking to the received satellites (e.g. the message `Acquiring GPS Lock` displays).

When a GPS solution has been found and locked, the current time and date are displayed as received from GPS. Also displayed are the number of detected satellite vehicles (SVs in View), and the number of satellites the GPS system has locked to (SVs in Fix). The last line reports the lock status of the GPS system. GPS periodically provides time synchronization with the

SRG-4400, which maintains the count between the synchronization events by counting field or frame pulses.

```

GPS DateTime (UTC)
GPS Solution found:
Running Time (UTC)           =           hh:mm:ss:ff
SVs in View = XX             in Fix = xx
Weekday   Date       Month   Year
xLocked to GPS

```

Figure 5.12 GPS DateTime (UTC) Menu

If the SRG-4400 is set for a Genlock Mode other than one of the GPS options, the current time and date are displayed as received from GPS. The last line of the menu reports that the selected Genlock Mode is not associated with the GPS system.

NTP DateTime (UTC)

The menu for NTP DateTime (UTC) is for information only - there are no editable fields. If the NTP option is enabled, the status information that the menu reports will depend on the configuration settings made in the NTP sub-menu (-System Setup | Network), e.g., whether the NTP System is turned off or whether a solution is being searched for.

When an NTP solution has been found, the current time and date are displayed from the user-defined NTP server. NTP periodically provides time synchronization with the SRG-4400, which maintains the count between the synchronization events by counting field or frame pulses.

If the SRG-4400 is set for a Genlock Mode other than NTP, the current time and date are displayed as received from NTP. The last line of the menu reports that the selected Genlock Mode is not associated with the NTP system.

```

NTP DateTime (UTC)
tLocked to NTP
Running Time           =           hh:mm:ss:ff
-NTP time Uncertainty =           nnnnms
Weekday   Date       Month   Year
Locked to Video

```

Figure 5.13 NTP DateTime (UTC) Menu

If the menu line Daylight Saving in the UTC DateTime menu is set to User Defined, the time and date fields of these menus can be edited. If the menu line Daylight Saving is set to Off or Automatic, editing is disabled.

The menus for Summer DST Event and Winter DST Event indicate the time and date for the next change in daylight saving time. At the indicated time and date, an hour will be added to or subtracted from SPG Time. For some countries these dates are automated. The dates of a change to or from daylight saving time are dictated well in advance, and by using the Country Code in the UTC DateTime menu, these dates are automatically implemented. As an example: EU Daylight Saving.

Additional Information for the Summer/Winter DST

If the menu line Daylight Saving in the UTC DateTime menu is set to User Defined, the time and date fields of this menu can be edited. If the menu line Daylight Saving is set to Off or Automatic, editing is disabled.

The menus for Summer DST Event and Winter DST Event indicate the time and date for the next change in daylight saving time. At the indicated time and date, an hour will be added to or subtracted from SPG Time. For some countries these dates are automated. The dates of a change to or from daylight saving time are dictated well in advance, and by using the “Country Code” in the UTC DateTime menu, these dates are automatically implemented. As an example:



Note — *In the United Kingdom, Daylight Saving Time is referred to as British Summer Time (BST).*

Summer Time Rule:

- Start: Last Sunday in March
- End: Last Sunday in October
- Time: 1.00 am (01:00) Greenwich Mean Time (GMT)

Equation used to calculate the beginning of European Summer Time: Sunday $(31 - (5*y/4 + 4) \text{ mod } 7)$ March at 01.00 UTC

Equation used to calculate the end of European Summer Time: Sunday $(31 - (5*y/4 + 1) \text{ mod } 7)$ October at 01.00 UTC

For countries where the SRG-4400 does not support automatic implementation of daylight saving time, the dates can be entered manually in advance of each event and the automatic procedure will occur for that one event. A more detailed description of implementing a manual update of these event dates is given in the “Daylight Saving” menu description above.

A full list of countries for which DST is automatically supported is shown below.

Table 5.8 Countries that DST is Automatically Supported

Country	Start	End	Action Time
Australia	First Sunday in October	First Sunday in April the following year	02:00 local standard time (AEST=UTC+11, ACST=UTC+10.5)
Brazil	Third Sunday in October	Third Sunday in February the following year	DST starts at 00:00 on the third Sunday in October and ends at 00:00 on the third Sunday in February - unless the latter falls during Carnival, in which case, the end of DST is postponed by one week. The next six times in which the end of DST is scheduled to be postponed are 2012, 2015, 2023, 2026, 2034 and 2037. It is unknown whether this is 00:00 local time or local standard time, so local standard time has been chosen.
Canada	Second Sunday in March	First Sunday in November	Since 2007, all time changes take place at 02:00 local time
New Zealand	Last Sunday in September	First Sunday in April the following year	02:00 local standard time (NZST=UTC+12)

Table 5.8 Countries that DST is Automatically Supported

Country	Start	End	Action Time
USA ^a	Second Sunday in March	First Sunday in November	Since 2007, all time changes take place at 02:00 local time
European Union	Last Sunday in March	Last Sunday in October	01:00 UTC

a. The Energy Policy Act of 2005 Rule.

Additional Information for the Leap Second Event (UTC)

If the menu line “Leap Second” in the UTC DateTime menu is set to User Defined, the time and date fields of this menu can be edited. If the menu line “Leap Second” is set to Off, editing is disabled.

The menu for Leap Second Event (UTC) indicates the time and date for the next addition or subtraction of a Leap Second. At the indicated time and date, a second will be added to or subtracted from UTC Time. See previous paragraphs regarding editing of the available menu lines.

Leap Second Event

The Leap Second event is not regular; indeed it is usually only decided a few months in advance when a Leap Second is to be added. For this reason it is not possible for all versions of the SRG-4400 software to have the time and date of the next event coded into the software. Historically the Earth's spin is slowing down but some scientists think that global warming may make the Earth's spin increase. In this case, Leap Seconds would occasionally need to be subtracted.

When a positive leap second is added at 23:59:60:00 UTC, it delays the start of the following UTC day (at 00:00:00:00 UTC) by one second, effectively delaying the UTC clock.

Announcement of Leap Seconds

The International Earth Rotation and Reference Systems Service (IERS) announces the insertion of a Leap Second whenever the difference between UTC and UT1 approaches 0.6 s, to keep the difference between UTC and UT1 from exceeding 0.9 s. IERS publishes announcements every six months, detailing whether Leap Seconds are to occur or not, in its “Bulletin C”. Such announcements are typically published well in advance of each possible Leap Second date - usually in early January for June 30 and in early July for December 31. Because the Earth's rotation rate is unpredictable in the long term, it is not possible to predict the need for them more than six months in advance. Leap Seconds have been added since 1972:

Table 5.9 Leap Seconds

Year	June 30	December 31	Year	June 30	December 31	Year	June 30	December 31
1971	--	--	1986	0	0	2001	0	0
1972	+1	+1	1987	0	+1	2002	0	0
1973	0	+1	1988	0	0	2003	0	0
1974	0	+1	1989	0	+1	2004	0	0
1975	0	+1	1990	0	+1	2005	0	+1
1976	0	+1	1991	0	0	2006	0	0
1977	0	+1	1992	+1	0	2007	0	0
1978	0	+1	1993	+1	0	2008	0	+1
1979	0	+1	1994	+1	0	2009	0	0
1980	0	0	1995	0	+1	2010	0	0
1981	+1	0	1996	0	0	2011	0	0
1982	+1	0	1997	+1	0	2012	+1	0
1983	+1	0	1998	0	+1	2013	0	
1984	0	0	1999	0	0	2014	0	
1985	+1	0	2000	0	0	2015		

Semi automated support for Leap Seconds is built-in until 2034.

The operator programs in a UTC date and UTC time at which the Leap Second event is required. On this date, at this time, a Leap Second is automatically added. International convention is that Leap Seconds are added, so the time sequence is:

- 23: 59: 59 UTC
- 23: 59: 60 UTC
- 00: 00: 00 UTC
- 00: 00: 01 UTC

In a television station, 00:00:00 UTC might be in the middle of your busy schedule. If this is so, you can choose another UTC time at which to action the Leap Second; for instance at

02:00:00 UTC the following morning. Only the date and hour at which the Leap Second

occurs is programmable. These dates are input as UTC so you may have to take account of your time zone and daylight saving status.

Once the Leap Second event occurs, all the subsequent timecodes are recalculated so that they will also have moved by one second. Subsequent Leap Seconds can be added by the operator as they are announced.

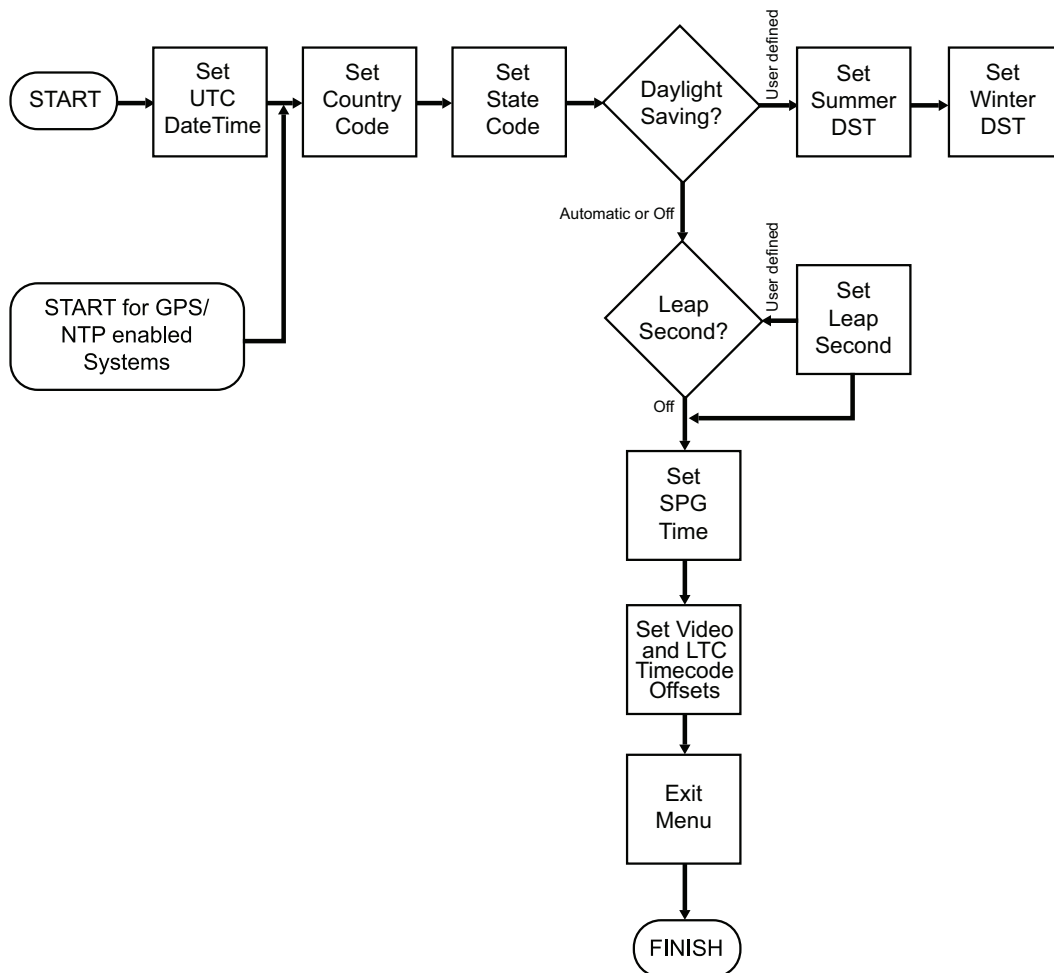

Figure 5.14 Time/Date Settings

Genlock Menus

The SRG-4400 has a very stable 10MHz internal oscillator. The SRG-4400 can free-run on this 10MHz reference and maintain long term stability.

Alternatively, the SRG-4400 can Genlock to an NTSC, or PAL B/G video reference. In this mode, the long term stability is defined by the external reference.

In a third mode the SRG-4400 can frequency lock to a reference from an external oscillator. Again, in this mode, the long term stability is defined by the external oscillator.

In a fourth mode, the SRG-4400 can Genlock to a reference from GPS, with the 10MHz internal oscillator being disciplined by the GPS system.

When locked to a Composite video signal, the lock will be frequency and phase related. When locked to an external oscillator, the lock will be frequency related only.

When locking to GPS, the lock mode can be selected from the following options:

- Time lock
- Time and Frequency lock
- Time and Frequency and Phase lock

Genlocking to an External Video Reference

The SRG-4400 Genlock to an external video reference in the following manner. As soon as a video reference is applied, it is evaluated, usually within 2 seconds, and, if valid, the Genlock system performs an initial “quick-lock” to quickly achieve field and line lock. Then, a “slow-lock” is performed in order to achieve sub-carrier lock, and ultimately Sc-H lock. Both of these lock modes are designed to “glide” the SRG-4400 video output(s) smoothly towards the required lock point.

For situations where the reference and the SPG output are quite close to each other timing-wise, this Genlocking process may happen quite quickly, within a few seconds or so. At other times, especially when a PAL reference is four fields removed from the required lock point, the process to complete the full Genlock process may take as long as 15 seconds.

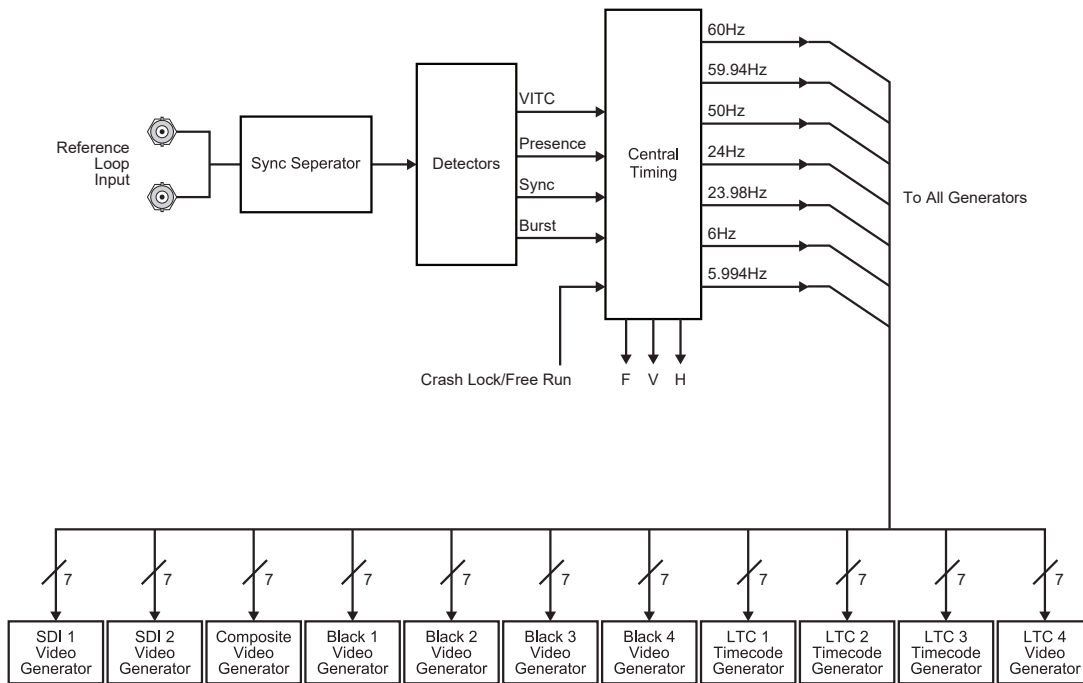

Figure 5.15 Genlock to External Video Reference

All but two of these menu lines report status information regarding the Genlock system. The remaining two items (Lock Mode and Unlock Mode) can be configured by the user.

Menu Descriptions

Lock Mode	=	Internal Lock
Lock Mode	=	Internal Lock
Unlock Mode	=	Relock
- Lock Status	=	Locked
- Ref Signal	=	1080 59.94p
- GPS Status	=	Locked
- NTP Status	=	Locked to NTP
- VITC Status	=	VITC Found
- MHz Status	=	

Figure 5.16 Genlock Menu Example

Lock Mode

This menu line allows the user to select the required Genlock mode of the SRG-4400. The options in the field are:

- Internal Lock — Locks to the internal 10MHz oscillator
- Genlock — Lock to an external CVBS video signal
- MHz Lock — Lock to an external frequency reference signal
- GPS T+F+Phase Lock
- GPS T+Freq Lock — Lock to a GPS signal from a connected antenna
- GPS Time Lock

The “GPS” and “NTP” Lock options are only available when these options are enabled.

Unlock Mode

This menu line allows the user to select the required action when reference is restored in Genlock mode. The options in the field are:

- Internal Lock — Locks to the internal 10MHz oscillator
- Relock — Re-lock to an external reference

Lock Status

This menu line reports the status of the Genlock system. For video and frequency lock modes, the options in the field will appear as:

- Internal Lock — appears under two conditions: when the SRG-4400 is set for Lock Mode = Internal Lock, and when Lock Mode = Genlock and the external reference is absent.
- Lost Lock — appears when the SRG-4400 detects that the external Genlock video reference has changed, is missing, or of an unrecognized format.
- Locking — displays while the SRG-4400 is actively Genlocking to the external Genlock video reference.
- Locked — displays when the SRG-4400 has successfully Genlocked to the external Genlock video reference.
- Locked to 10MHz — displays when the SRG-4400 has locked to the external 10MHz frequency reference.

Additional options will appear in the field, mirroring a subset of the field options detailed in the following sections.

Ref Signal

If an external Genlock reference is present, details regarding the format of the reference are displayed in this menu line.

The options in the field will appear as:

- No signal
- 525 NTSC59.94i
- 625 PAL 50i

GPS Status

This menu line reports the status of the GPS system. The options in the field will appear as:

- Option is Off — appears when GPS Lock Mode has been selected, and the option is not enabled.
- Acquiring GPS — displayed when the SRG-4400 is actively searching for satellites and locking to the time information within the GPS signal.
- xLocked to GPS — (where x = t, i, a or p) is displayed when the SRG-4400 has successfully locked to the pre-selected mode of GPS Locking (the display progresses in sequence, as listed):
 - › tLocked to GPS GPS Time Locked
 - › iLocked to GPS Basic Frequency acquired
 - › aLocked to GPS Better Frequency acquired
 - › pLocked to GPS GPS Phase Locked

NTP Status

This menu line reports the status of the NTP system. The options in the field will appear as:

- Option is Off — displayed when the NTP Lock Mode has been selected, and the option is not enabled.
- NTP is Off — displayed when NTP Option has been enabled, but is set to be neither a Client nor a Server.
- Acquiring NTP — displayed when the SRG-4400 is actively searching for and locking to NTP information from a remote server.
- Locked to NTP — displayed when the SRG-4400 has successfully locked to a remote NTP Server.
- Server Mode — displayed when the SRG-4400 is configured to be an NTP Server.

VITC Status

This menu line reports the status of the VITC system. The options in the field are:

- Ignoring VITC — appears when the Lock Mode is not Genlock+VITC, and indicates that there is no VITC to search for or lock to.
- Start VITC loop — appears briefly as the Lock Mode is set to Genlock+VITC.
- Searching VITC — appears while the SRG-4400 is searching for a valid VITC signal.
- VITC found — appears briefly when the SRG-4400 has found a valid VITC signal.
- Locking to VITC — appears while the SRG-4400 is actively genlocking to the VITC signal.
- tLocked to VITC — appears when the SRG-4400 has successfully genlocked to the VITC signal.

If you have more than 1 valid genlock reference source available or connected to lock to, the Lock Status setting will follow a hierarchy to lock to the most suitable reference. Additionally, the current Lock Status is reported on the bottom line of the Logo and Time stand-by screens on the Front Panel Display.

System Setup Menu

The System Setup menu appears below:

```
System Setup Menu
- Temp Report      Menu Enter  ->
- Event Report     Menu Enter  ->
- System Report    Menu Enter  ->
- GPS Report       Menu Enter  ->
- Configuration   Menu Enter  ->
- Network          Menu Enter  ->
- Option Enable    Menu Enter  ->
- Calibration      Menu Enter  ->
- LipSync Report   Menu Enter  ->
```

Figure 5.17 System Setup Menu Example

When the GPS option is not installed/enabled, the “GPS Report” line appears as:
“-GPS.....Option not enabled”

The System Setup menu provides a gateway to the less frequently used options in the SRG-4400. These options include:

- Extended information in the form of reports
- Extended configuration options
- Access to factory settings that the user should never have to access or adjust, but may contain useful information to communicate to the factory during a service event.



Note — *Reports menus contain information only; there are no editable fields in these menus.*

Temperature Reports

The Temperature Report appears below (general form).

Temperature	Now	Max	Min
+3v3 Regulator	45	45	45
+1v2 Regulator	45	45	45
N+1 Interface	45	45	45
N+1 Left PSU	45	45	45
N+1 Right PSU	45	45	45
L PSU turned on		nnnnn	times
L PSU on for		hhhhh.ddd	hours
R PSU turned on		nnnnn	times
R PSU on for		hhhhh.ddd	hours

Figure 5.18 Temperature Reports Menu Example

The Temperature Report provides information on the temperature sensors within the SRG-4400. A typical example might look like: +3v3 Regulator 42 45 41

Depending on the exact configuration and options in the SRG-4400, only those sensors that are detected will be displayed. If a sensor is installed but has failed, the description in the relevant line appears as: Fixed PSU -Sensor absent

PSU Reports

The menu lines: “L PSU turned on nnnnnn times “, “L PSU on for hhhhhh.ddd hours “, “R PSU turned on nnnnnn times “and “R PSU on for hhhhhh.ddd hours.

These menu lines report the power cycle counts and “in service” times for both of the PSUs installed in the Dual Redundant PSU SRG-4400.

When there is only one PSU, as in the single PSU variant of the frame, the SRG-4400, these menu lines appear as:

```

"PSU turned on nnnnnn times "
"PSU on for hhhhhh.ddd hours "

```

The sub-field “nnnnnn” is a numerical count of the number of times the respective PSU has been power cycled. The sub-field “hhhhh.ddd” is a numerical count of the number of hours the respective PSU has been powered, where “hhhhh” displays whole hours, and “ddd” displays fractions of an hour to 3 decimal places.

Because the temperature report includes not only the current, minimum and maximum temperatures detected by the installed temperature sensors, but also power supply “in-service” data, this information is useful if you are experiencing reliability problems in an extreme environment.

Event Report

The Event Report appears below (example form).

Event Menu			
Ev	00010	NewMaxTemp2	
	03.22.21.255.13		12 April 2013
Ev	00009	EthernetLinkMade	
	03.22.18.700.13		12 April 2013
Ev	00008	PowerOn	
	03.22.18.700.13		12 April 2013

Figure 5.19 Event Report Menu Example

The Event Report provides access to the last 99 events recorded by the SRG-4400. These events may relate to normal expected functionality or to systemic errors. This information might be useful in monitoring and diagnosing a system problem outside the SRG-4400, or a reliability problem within the SRG-4400.

```

Ev nnnnn NewMinTempAlarm0
23.59.59.999 01 September 2012

```

This menu row pair provides details of the recorded event.

- The first row provides an event number and the description of the event.
- The second row provides the event time expressed as hours: minutes: seconds: milliseconds, and the event date.

The most recent event is always displayed at the top of the menu. A large number of different events can be recorded.

Table 5.10 Applicable Events

Event	Code	Event	Code
EventDefault	0	EventNewMaxTempAlarm1	27
Event Power On	1	EventNewMaxTempAlarm2	28

Table 5.10 Applicable Events

Event	Code	Event	Code
EventWatchdogReturn	2	EventNewMaxTempAlarm3	29
EventLVDReturn	3	EventNewMaxTempAlarm4	30
EventPowerOff	4	EventNewMaxTempAlarm5	31
EventLVDEvent	5	EventNewMaxTempAlarm6	32
EventnSetUTCtimeFromGPS	6	EventNewMaxTempAlarm7	33
EventGPSTimeLost	7	EventNewMinTemp0	34
EventSetUTCtimeFromNTP	8	EventNewMinTemp1	35
EventNTPTimeLost	9	EventNewMinTemp2	36
EventLeftPSUfail	10	EventNewMinTemp3	37
EventLeftPSUreturn	11	EventNewMinTemp4	38
EventRightPSUfail	12	EventNewMinTemp5	39
EventRightPSUreturn	13	EventNewMinTemp6	40
EventPSULCDCancelManual	14	EventNewMinTemp7	41
EventPSULCDCancelAuto	15	EventNewMinTempAlarm0	42
EventPSULCDRepeatManual	16	EventNewMinTempAlarm1	43
EventPSULCDRepeatAuto	17	EventNewMinTempAlarm2	44
EventNewMaxTemp0	18	EventNewMinTempAlarm3	45
EventNewMaxTemp1	19	EventNewMinTempAlarm4	46
EventNewMaxTemp2	20	EventNewMinTempAlarm5	47
EventNewMaxTemp3	21	EventNewMinTempAlarm6	48
EventNewMaxTemp4	22	EventNewMinTempAlarm7	49
EventNewMaxTemp5	23	EventEthernetLinkMade	50
EventNewMaxTemp6	24	EventEthernetLinkLost	51
EventNewMaxTemp7	25	EventGPSSetTimecodeFromGPSFlag	52
EventNewMaxTempAlarm0	26	EventGPSUnSetTimecodeFromGPSFlag	53

System Report

The System Report appears below.

```

192.xxx.xxx.xxx
Ethernet          100Mbps      Full Duplex
ArmFile_0x00200000_vxx_xxx.ata
XilFile_0x30000000_vxx_xxx.ata
PatFile_0x34000000_vxx_xxx.ata
LogFile----- none present
BMPFile----- none present
AudFile----- none present
Bootware vxxxxxx Software vxxxxx
Hardware vxxxxx Firmware vxxxxx

```

Figure 5.20 System Report Menu Example

The System Report provides complete version information for the hardware, firmware and software elements that make up the SRG-4400.

192.xxx.xxx.xxx

This field reports the user programmed Ethernet IP Address of the SRG-4400. The options in the sub-fields appear as: 0 through 255

Ethernet

This field reports the detailed Ethernet link status of the SRG-4400. The options in the first sub-field appear as:

- <blank>
- 10Mbps
- 100Mbps

The options in the second sub-field appear as:

- No link
- Full Duplex
- Half Duplex

Additionally, the current Ethernet link status is reported on the bottom line of the Logo or Time stand-by screens on the Front Panel Display.

ArmFile

The Arm File menu link is in the form: "ArmFile_0x00200000_vxx_xxx.ata".

The sub-field "0x00200000" is the load address. The sub-field "vxx_xxx" is the version number.

Updates of this file may be uploaded via the Ethernet interface using the procedure outlined in the section "**Software Upgrades**" on page 4-7.

XilFile

The Xilinx File menu line is in the form: "XilFile_0x30000000_v00_21x.ata"

The sub-field "0x30000000" is the load address. The sub-field "v00_21x" is the version number.

Updates of this file may be uploaded via the Ethernet interface using the procedure outlined in the section "**Software Upgrades**" on page 4-7.

PatFile

The Pattern File menu line is in the form: "PatFile_0x34000000_vxx_xxx.ata".

The sub-field "0x34000000" is the load address. The sub-field "vxx_xxx" is the version number.

Updates of this file may be uploaded via the Ethernet interface using the procedure outlined in the section "**Software Upgrades**" on page 4-7.

LogFile

This menu line reports whether there is a user-uploaded bitmap logo file stored in the SRG-4400.

If the file is absent or empty, the menu line displays as: "LogFile ---- not present".

If there is a valid bitmap logo file present, the menu line displays as:

"LogFile_0x38000000_xx_xx.ata". The sub-field "0x38000000" is the load address. The sub-field "vxx_xxx" is the version number.

Bootware and Software Fields

The Bootware vxxxxx field indicates the bootware version in use. This is not usually modified by field upgrades as it relates to the motherboard bootware components in the SRG-4400.

The Software vxxxxx field indicates the software version in use. This can be modified in the field when new versions of the software are uploaded via the Ethernet interface.

Hardware and Firmware Fields

The Hardware vxxxx field indicates the hardware version in use. This is not usually modified by field upgrades as it relates to the motherboard hardware components in the SRG-4400.

The Firmware vxxxx field indicates the firmware version in use. This is not usually modified by field upgrades as it relates to the motherboard firmware components in the SRG-4400.

GPS Report

The GPS Report appears below:



GPS Report		
SV in Fix	=	nn
GPS SVs in view	=	nn
GLO SVs in view	=	nn
Leapsecond in pend	=	No
Lxx SV	=	mm
Pxx SV	=	mm

Figure 5.21 GPS Report Menu Example

The GPS Report displays information regarding the current status of the GPS system. Access to this report will only be possible if the GPS option has been installed and enabled.

The information that appears in this report consists of a list of detected satellite vehicles (SV) and their signal-to-noise ratio (SNR). Note that SNR is not defined for the GLONASS satellite system. Additionally, a “map” is displayed on the Front Panel LCD, showing a graphical representation of the satellite locations in the sky.

GPS Report Fix

The sub-field in this menu line indicates the total number of satellites currently being detected, and appears as 00 through 24.

Pxx SV, Lxx SV

The menu lines starting with “P” and “L” represent which satellite system is being referred to:

- **P** — for the American GPS system
- **L** — for the Russian GLONASS system

The first sub-field is used to chronologically index the list of detected satellites, and has the following value range: 01 through 12 for both systems.

The second sub-field indicates the assigned PRN of the satellite vehicle, and has the following value ranges:

- 01 through 32 for the American GPS system
- 65 through 88 for the Russian GLONASS system
- xx for a non-detected satellite

The third sub-field indicates the signal-to-noise ratio of the received signal from the satellite vehicle, and has the following value range:

- 01 through 58 for the American GPS systems
- xx for a non-detected satellite

Configuration Menu

The Configuration menu appears below:

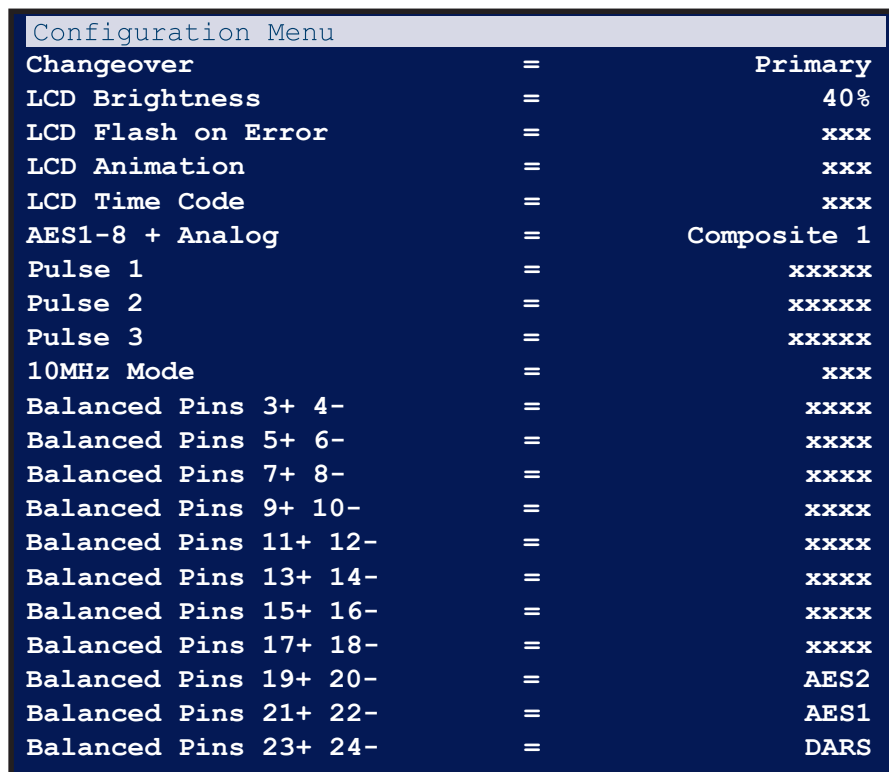

Configuration Menu		
Changeover	=	Primary
LCD Brightness	=	40%
LCD Flash on Error	=	xxx
LCD Animation	=	xxx
LCD Time Code	=	xxx
AES1-8 + Analog	=	Composite 1
Pulse 1	=	xxxxx
Pulse 2	=	xxxxx
Pulse 3	=	xxxxx
10MHz Mode	=	xxx
Balanced Pins 3+ 4-	=	xxxxx
Balanced Pins 5+ 6-	=	xxxxx
Balanced Pins 7+ 8-	=	xxxxx
Balanced Pins 9+ 10-	=	xxxxx
Balanced Pins 11+ 12-	=	xxxxx
Balanced Pins 13+ 14-	=	xxxxx
Balanced Pins 15+ 16-	=	xxxxx
Balanced Pins 17+ 18-	=	xxxxx
Balanced Pins 19+ 20-	=	AES2
Balanced Pins 21+ 22-	=	AES1
Balanced Pins 23+ 24-	=	DARS

Figure 5.22 Configuration Menu Example

The Configuration menu provides access to a range of features that determine the functionality of the SRG-4400 not otherwise covered by other menu settings. These options are typically set up during the system commissioning of the SRG-4400, and thereafter are unlikely to be changed.

Changeover

The options in the sub-field appear as: Primary, and Backup.

The SRG-4400 can be installed with a partner SRG-4400 and an ACO-4400A. In this configuration, one of the SRG-4400 is defined as PRIMARY and the other as BACKUP. This menu row item allows the selection of PRIMARY or BACKUP. The polarity of the ONAIR tally is also controlled by this selection.

LCD Brightness

This menu row allows the user to select the best LCD display parameters for the ambient lighting conditions. The options are: 0% through 100% in 16 steps.

LCD Flash on Error

This menu row allows the user to select the LCD and Button to flash (or not) when an error is reported. The options are:

- Off — no flash
- On — LCD and the Select button flash when errors are reported

LCD Animation

This menu allows the user to select the animation mode on the LCD. When the Timecode screen is selected, the display will be either static, or will cycle alternately with the Logo screen. The options are:

- Off — no animation
- On — animation when display is left in Timecode screen

LCD Timecode

This menu allows the user to choose which time within the SRG-4400 is displayed on the LCD. When the Timecode is selected, the display will show the Time Selected. The options are: LTC1-4, Black1-4, SDI1-4, SPG Time, UTC Time, and GPS Time.



Note — All of LTC1-4, Black1-4 and SDI1-4 include DST when it is active.

If the Time is SPG Time, the digits are separated by “. . .” (e.g. 09.34.05.10). Note that SPG time does not include DST changes.

If the selected time is drop frame, the digits are separated by “; ; ;” (e.g. 09;34;05.10).

If the selected time is not drop frame, the digits are separated by “: : :” (e.g. 09:34:05:10).

AES1-8 + Analog

This menu item allows the user to select the appropriate video from which the AES and Analog Audio are referenced. The options are: SDI1, SDI2, and Composite1.

Pulse

This menu row triplet allows the user to select which pulse type appears on the rear panel BNCs of the multifunction option module.



Note — Options 1 through 7 produce pulses determined by the format of the CVBS output.

The options in the field are:

- Mixed Sync
- Mixed Blanking
- Burst Gate
- PAL Square
- Line Drive
- Field Drive
- F1/L7 or F1/L10
- 6Hz/30Hz
- 6Hz/29.97Hz
- Word Clock 48KHz
- Word Clock 44.1KHz

10MHz Mode

The SRG-4400 can lock to an external 10MHz reference. This reference can be sine, square or pseudo-sine.

The SRG-4400 generates its own 10MHz with pseudo-sine wave output.

There is a changeover relay within the SRG-4400 selecting either the SRG-4400 generated 10MHz or the external 10MHz. This is used to allow 10MHz to be passed to other external equipment if the SRG-4400 is powered down either purposefully or due to failure.

This menu item selects the operation mode of the 10MHz relay. The options are: External, Internal, and Automatic.

Programmable Balanced Outputs

This menu row allows the user to select which balanced signal types appear on the rear panel when using the Breakout option. Any of the following signal types may be selected on any programmable balanced pin output pair (i.e. all 8 programmable outputs may be the same signal, or may be all different, etc.).

Note that some pin pairs are fixed (and are not configurable) as follows:

- Pin 19+, Pin 20- are set to AES2
- Pin 21+, Pin 22- are set to AES 1
- Pin 23+, Pin 24- are set to DARS
- Pin 25+, Pin 26- are set to Left Analog Audio
- Pin 27+, Pin 28- are set to Right Analog Audio

Network Menu

The Network menu appears below:

```
Network Menu
IP Address      =      000.000.000.000
Subnet Mask     =      000.000.000.000
Gateway        =      000.000.000.000
- MAC Address   =      000.000.000.000
- NTP           Menu Enter ->
- DashBoard     Menu Enter ->
- Backup Device Menu Enter ->
```

Figure 5.23 Network Menu Example

When the NTP option is not enabled, the line appears as:

```
"-NTP.....Option not enabled"
```

The Network menu, and the associated sub-menus, allows the user to configure and control the behavior of the Ethernet system within the SRG-4400.

Before proceeding, the user must contact their Network Administrator, and obtain suitable IP addresses, etc., that will need to be programmed within this menu.

IP Address

This menu line allows the user to enter the IP address of the SRG-4400. The options in the sub-fields "000" are: 000 through 255 where 000" is the default "no action" setting.

To change the settings:

1. pressing the rotary control advances through each sub-field.
2. rotating the rotary control changes the value of the currently selected sub-field.

SubNet Mask

This menu line allows the user to enter the SubNet Mask address of the SRG-4400.

The options in the sub-fields are: 000 through 255. where "000" is the default "no action" setting.

To change the settings:

1. pressing the rotary control advances through each sub-field
2. rotating the rotary control changes the value of the currently selected sub-field.

Gateway

This menu line allows the user to enter the Gateway address of the SRG-4400. Typically, this might be the IP address of a network hub to which the SRG-4400 is connected.

The options in the sub-fields are: 000 through 255 where "000" is the default "no action" setting.

To change the settings:

1. pressing the rotary control advances through each sub-field
2. rotating the rotary control changes the value of the currently selected sub-field.

MAC Address

This menu line displays the MAC Address (Media Access Control), a unique, read-only identifier assigned to network interfaces for communications on the physical network segment.

This menu item cannot be changed - the MAC address is stored in a hardware device and is unique to each SRG-4400, and is also used to provide unique update keys when enabling options within the unit.

Other Menus

These menu lines provides access to subsequent menu levels, as indicated. These are defined in the following sections.

```
``-NTP           Menu Enter ->”
```

```
``-DashBoard    Menu Enter ->”
```

```
``-Backup device Menu Enter ->”
```

NTP Menus

Access to the NTP menu is only possible if the NTP option is enabled.

The NTP menu allows the user to configure the Ethernet port to provide (Server Mode) or request (Client Mode) time information using Network Time Protocol. Access to this menu will only be possible if the NTP option has been enabled.

The menu line reports the current NTP time. The field “hh:mm:ss:ff” displays hours, minutes, seconds, and frames in the 24-hour format.

If the NTP Client system has yet to receive a valid time, the menu line appears as: NTP Menu No NTP time.

NTP System is Off

This menu line allows the user to control whether the SRG-4400 is configured to be an NTP Client or NTP Server, or whether the NTP System is off.

```
NTP Menu hh:mm:ss:ff
The NTP Server is.....off
```

Figure 5.24 NTP Menu Example — Off

The options in this menu line appear as:

- The NTP System is off
- This is an NTP Client
- This is an NTP Server

NTP Client Mode

Access to the NTP menu is only possible if the NTP option is enabled.

```
NTP Menu hh:mm:ss:ff
This is an NTP.....Client
Find server on 000.000.000.000
Poll Server every 240 secs
- Poll Status = tLocked to NTP
- NTP time Uncertainty = nnnnms
```

Figure 5.25 NTP Client Menu Example

Find Server on

This menu line allows the user to define the IP address of a remote web-based NTP Server from which the SRG-4400 will periodically request time information. The address can be changed to one preferred by the user.

The options in the sub-fields are: 000 through 255. The value of 000 is the default “no action” setting.

To change the settings:

1. pressing the rotary control advances through each sub-field
2. rotating the rotary control changes the value of the currently selected sub-field.

Poll Server

This menu line allows the user to set the interval (in seconds) at which the SRG-4400 requests NTP time information from the specified time server.

The options in the Poll Interval field are:

- Never
- 60 secs
- 2/5/10/30/60 minutes
- 2/4/8 hours

One initial power-up, the SRG-4400 will poll the NTP Server every 10 seconds until a reply is received, and then drop back to the user-selected value as programmed in this menu sub-field.

Poll Status

This menu line reports the current poll status of the designated NTP Server address.

Initially, the sub field will report that the SRG-4400 is currently waiting for replies from the designated NTP Server: `Poll Status = Acquiring NTP.`

When replies from the designated NTP Server produce consistently accurate time stamps, the sub-field will change to: `Poll Status = tLocked to NTP.`

During NTP acquisition, the following menu line appears below the Poll Status line: `Unlocked Poll every 010 secs.`

This menu line reports the polling interval when the NTP Server is being actively polled during initial acquisition. The interval of 10 seconds should ensure that at least one reply will be found very quickly, After a reply has been received, the polling interval drops back to the user setting made in the menu entry `Poll Server every 240 secs` above, and the following menu line appears.

The menu line `NTP time Uncertainty = nnnnms` reports the average variation in successive NTP replies.

Server Mode

An example of NTP Server Mode menu is below.

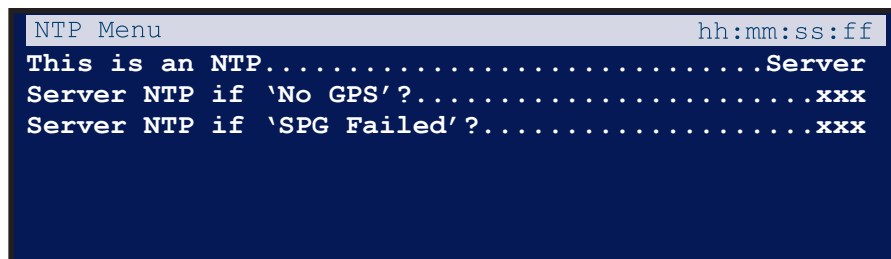

```
NTP Menu                               hh:mm:ss:ff
This is an NTP.....Server
Server NTP if 'No GPS' ?.....xxx
Server NTP if 'SPG Failed' ?.....xxx
```

Figure 5.26 NTP Server Menu Example

Serve NTP if 'No GPS'

This menu line determines whether the SRG-4400 will serve NTP requests when the GPS option is not enabled.

The options in the sub-field are:

- No — NTP Server will not reply to NTP requests while GPS is disabled.
- Yes — NTP Server will reply to NTP requests while GPS is disabled.

When set for “Yes”, NTP time will be used to serve time requests for a limited time after which NTP time requests will be ignored.

Serve NTP if 'SPG failed'

This menu line determines whether the SRG-4400 will serve NTP requests while an accompanying Changeover unit has detected an error on the unit.

The options in the sub-field are:

- No — NTP Server will not reply to NTP requests while the SRG-4400 has 'failed'.
- Yes — NTP Server will reply to NTP requests while the SRG-4400 has 'failed'.

DashBoard Menu

The Dashboard menu appears below:

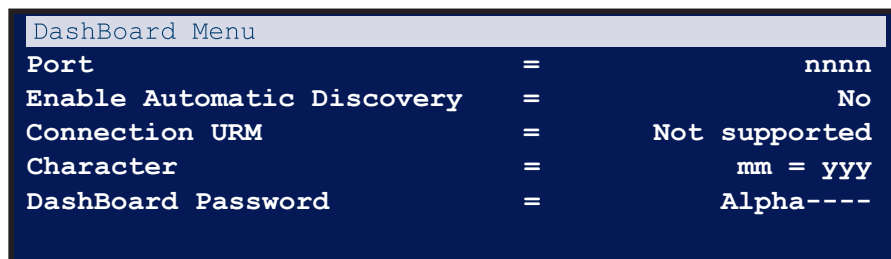

DashBoard Menu		
Port	=	nnnn
Enable Automatic Discovery	=	No
Connection URM	=	Not supported
Character	=	mm = yy
DashBoard Password	=	Alpha----

Figure 5.27 DashBoard Menu Example

The DashBoard menu displays information relating to communications between the SRG-4400 and the external PC-based Remote Control Program.

Port

This menu line allows the user to set the Ethernet Port through which the SRG-4400 communicates with the external PC-based Remote Control Program.

The options in the sub-field are: 5253 (default), and 6666.

Enable Automatic Discovery

This menu is not implemented.

Connection URM

This menu is not implemented.

Character and DashBoard Password

These menu lines only appear when the Connection URM menu is to “Managed”. This menu doublet allows the user to select and edit the Dashboard password.

- The options in the field “mm” are: 01 through 09. There are a maximum of 9 characters in the password. “mm” selects which character is ‘active’ and hence editable in the menu. In the selected DashBoard Password line, as “mm” is changed, a cursor gives a visual indication of which character is active.
- The options in the field “yyy” are any valid alpha-numeric character from the following:
 - › <space>
 - › Numeric: 0123456789
 - › Uppercase: ABCDEFGHIJKLMNOPQRSTUVWXYZ
 - › Lowercase: abcdefghijklmnopqrstuvwxyz

The first non-alpha-numeric character terminates the password. The only character available to do this is the space character, which is accessed by rotating the control fully anti-clockwise. The edited password is applied as the menu is exited.

Keep the following in mind:

- After adjusting the field “yyy”, use the Escape/Back button to select the next character to edit, then press Select to edit the next character, etc.

- When using the available front panel controls, editing of the characters in the Dashboard Password is performed in “Overtyping” mode, i.e., it is not possible to “Insert” or “Delete” characters.
- When you edit a pre-programmed Dashboard Password, start from character position 1; do not use spaces between the characters (see above); overtype with spaces (char.#32) any extraneous characters at the end of the password.

Backup Device Menu

The Backup Device menu appears below:

```
Backup Device Menu
Poll the Primary SPG on.....
IP Address                    =    000.000.000.000
Subnet Mask                   =    000.000.000.000
Poll is disabled.....
This is PRIMARY.....so never poll
```

Figure 5.28 Backup Device Menu Example

The Backup Device menu is only used when the SRG-4400 is set to be the Backup unit in a Changeover pair.

Poll the Primary SPG on...

This menu line informs the user that these menu items relate to the Primary SRG-4400 of the Changeover pair.

IP Address, SubNet Mask

These menu lines allow the user to set the IP and SubNet Mask addresses for the Primary SRG-4400 of the Changeover pair.

The options in all menu sub-fields “000” are: 000 through 255 where “000” is the default no-action setting.

To change the settings

1. pressing the rotary control advances through each sub-field,
2. rotating the rotary control changes the value of the currently selected sub-field.

Poll is disabled

This menu line displays if the SRG-4400 is set as the Primary unit in a Changeover pair. It informs the user that the SRG-4400 is the Primary unit of a Changeover pair, and consequently, polling (of the remote device) is disabled.

When the SRG-4400 is set as the Backup unit in a Changeover pair, this menu line appears as: “Poll every.....nnn secs”. This menu line enables the user to set the Polling Interval (in seconds). The options in the field are: 010 through 240.

This is PRIMARY, so never poll

This menu line appears if the SRG-4400 is set as the Primary unit in a Changeover pair. It informs the user that the SRG-4400 is the Primary unit of a Changeover pair, and consequently, polling (of the remote device) is disabled.

When the SRG-4400 is set as the Backup unit in a Changeover pair, this menu line appears as one of the following:

- “-Completed Polls = nnn” — Where the field “nnn” will increment in conjunction with the number of successful polls of the Primary unit.
- “-Completed Polls = nnn” — Where the field “= nnn” is blank if the previous line regarding the Polling Interval is set for “Never”.

Option Enable Menu

The Option menu appears below:

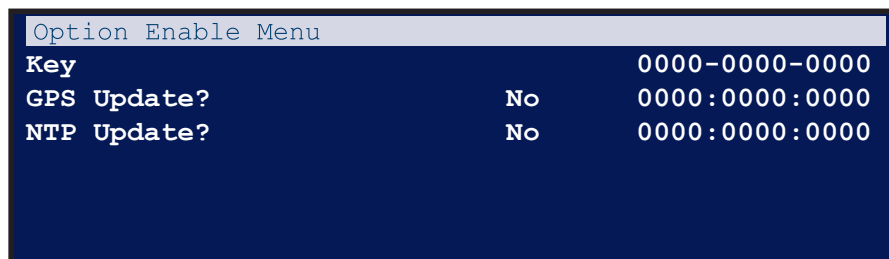

Option Enable Menu		
Key		0000-0000-0000
GPS Update?	No	0000:0000:0000
NTP Update?	No	0000:0000:0000

Figure 5.29 Option Enabled Menu Example

The Option menu allows the user to enable options designed into the SRG-4400. Authorized users enter Option Update Keys, supplied only after consultation with Ross Video.



Important — *Option Update Keys are in the form of a 12-character string. Each key is completely unique to a specified option in a particular SRG-4400. Keys will not work for other options on the same SRG-4400, nor on any other SRG-4400. Remember to store these keys in a safe place - you may need to re-enter them if a system error necessitates a system re-configuration.*

Key

Every time the SRG-4400 is powered on, this entry displays a pseudo-randomly generated 13-character key. This menu item cannot be changed by the user. This key is unique to each SRG-4400 and should be quoted when requesting any additional Option Enable Keys.

GPS Update, NTP Update

These menu lines allow the user to input the supplied Option Update Key(s) in order to enable the related option(s). Updates can be performed “live” - there is no requirement to re-boot or re-power the unit after key entry.

These menu lines will contain non-zero entries. These will be factory default values, and will be confirmed by the “:” between the character groups. For valid keys, the character groups will be separated by “-”.

The Timeable Black (TB) Option is always enabled, is not changeable, and will always contain character groups separated by “-”.

These menu options are always set to “No” upon entry - it requires a conscious action on the part of the user to set the option to “Yes” and thereby enable Option Update Key editing.

To enter an Option Update Key

1. Highlight the line for which you have a key
2. Press the rotary control. The cursor moves to the word “No”.
3. Rotate the rotary control to select “Yes”.
4. Press the rotary control. The cursor highlights the first character pair of the key.
5. Rotate the rotary control to select the desired character pair.
6. Confirm your selection by pressing the rotary control. The cursor moves to the next character pair.
7. Repeat through all 6 character pairs until you get back to the highlighted line.

8. When completed correctly, the separators between the character groups change from “:” to “-” to indicate that a valid key has been entered.
9. Exit properly from the menu system to permanently save your new settings. Your enabled option(s) should now be operational.



Note — *For the GPS and NTP systems, a power cycle may be required to fully complete the Option Update process.*

Calibration Menu

The Calibration menu appears below:

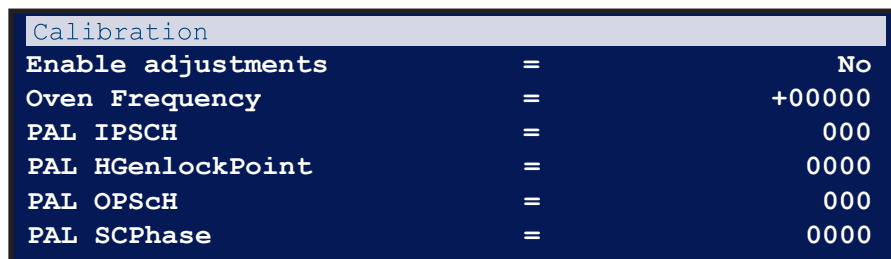

Calibration		
Enable adjustments	=	No
Oven Frequency	=	+00000
PAL IPSCH	=	000
PAL HGenlockPoint	=	0000
PAL OPScH	=	000
PAL SCPhase	=	0000

Figure 5.30 Calibration Menu Example



Important — The Calibration menu contains fundamental settings relating to the functionality and accuracy of the SRG-4400. These settings are programmed during initial testing, configuration and alignment. Under normal circumstances, it should not be necessary to adjust any of these settings after the unit has been installed.

It is a good idea to make a manual record of these settings in case they become corrupted or are inadvertently changed. A convenient way to achieve this is to print this page, record the stored values alongside the respective menu lines, then store the list in a safe place.

Enable Adjustments

This menu line enables the user to change any of the calibration settings in the remainder of this menu. This menu option is always set to “No” upon entry - it requires a conscious action on the part of the user to set the option to “Yes” and thereby enable calibration value adjustments.

The options are:

- No — Calibration is disabled (Default). The user may view the menu values at any time.
- Yes — Calibration is enabled. The user is able to change any of the preset values.

Oven Frequency

This menu line allows the user to adjust the frequency of the internal 10MHz oscillator.

When the SRG-4400 is configured for Internal Lock (refer to the section “**Genlock Menus**” on page 5-34), the video outputs on the SRG-4400 will “free run” compared to an external video signal from a known reference.

To set the 10MHz oscillator

1. View both the Composite output and the known reference on a vector scope.
2. On the vector scope, ensure that the known reference is also looped through to the EXT REF input, and that the EXT REF function is enabled.
3. Adjust the “Oven Frequency” menu value so that the Composite video output signal rotates at less than 1 cycle/second compared to the known reference.

When the SRG-4400 has a GPS receiver installed and enabled, this value is automatically adjusted by the SRG-4400, using embedded clock data in the GPS signal.

This setting varies from unit to unit.

PAL IPSCH, NTSC IPSCH

These menu lines allow the user to adjust the Sc-H settings relating to the Genlock video signal present at the REF-LOOP BNCs on the rear panel. This setting ensures that the 4-frame (PAL) or 2-frame (NTSC) SC-to-H relationship of the incoming signal will be reliably determined.

To set either of these values, access to test points on the main module is required. Therefore, no specific adjustment details will be outlined here.

These settings vary from unit to unit.

PAL HGenlockPoint, NTSC HGenlockPoint

These menu lines allow the user to set the value of the window used to align the H-timing system with the REF LOOP signal, and thereby control Sc-H locking.

To set either of these values, access to test points on the main module is required, as well as access to a special engineering sub-menu. Therefore, no specific adjustment details will be outlined here.

These settings are unlikely to change significantly from unit to unit. The default value for both PAL and NTSC is 0063.

PAL OPScH, NTSC OPScH

These menu lines allow the user to adjust the SC Phase of the video output relative to the reference input. This setting is used to provide “co-timed” video outputs when they are set for a video timing offset of 0°.

Specialized equipment is required in order for these settings to be determined. Therefore, no specific adjustment details will be outlined here. These settings vary from unit to unit.

PAL SCPhase, NTSC SCPhase

These menu lines allow the user to adjust the Sc-H settings relating to the video outputs. Specialized equipment is required in order for these settings to be determined. Therefore, no specific adjustment details will be outlined here. These settings vary from unit to unit.

CompGain, Black#

These menu lines allow the user to adjust the Gain and DC settings of the respective video outputs.

Each menu line displays the calibration values relating to the gain and d.c. settings of the relevant video channel DAC. Gain values are typically in the range 0-30; d.c. values are typically in the range 382-390.

Disclaimer

Most of these settings are determined during initial testing, configuration and alignment. They should not normally require adjustment or re-configuration during service. In some cases, specific test equipment or even custom apparatus is required to perform calibration and configuration.

On no account should the user attempt to alter any of these settings without proper authorization from Ross Video.

If problems are encountered, these settings can be re-instated. Contact Ross Video for further instructions.

To re-install one or more calibration settings

For the case where calibration values are simply being re-instated, simply advance the menu highlight to each parameter in turn, and rotate the rotary control to select the required value. Be careful not to rotate the rotary control for any setting that does not need to be changed. Be sure to exit from the menu to permanently save your settings.



Note — *During this calibration procedure, the video output being adjusted does not produce a video output. Make sure that you are viewing the menu on another video output from the one you are adjusting, or alternatively, use the front panel LCD.*

Troubleshooting

In This Chapter

Generally speaking, the SRG-4400 is reliable under normal steady-state operating conditions. If you are having problems, select the symptom from the list in this chapter that closely relates to your particular problem, and perform the checks / actions listed.



Notice — *Observe all cautions and warnings listed in the section “**Important Regulatory and Safety Notices to Service Personnel**” at the front of this manual.*

The following topics are discussed:

- Troubleshooting Checklist
- Equipment Checklist
- Contacting Ross Video Technical Support

Troubleshooting Checklist

Table 6.1 provides troubleshooting guidance for the SRG-4400.

Table 6.1 Possible Symptoms and Solutions

Symptom(s)	Cause(s)	Action
LCD not operational Video/Audio outputs missing	<ul style="list-style-type: none"> • Mains Power Missing • Power Supply fault • Bad power connection(s) 	<ul style="list-style-type: none"> • Check Mains Power • Check Mains lead integrity • Check rear panel Mains fuse • Check power supply fuse
Intermittent Operation	Bad power connection(s)	Check Mains Power connections
Corrupted output(s)	Corrupted data	<ol style="list-style-type: none"> 1. Remove Power 2. Wait 10 seconds 3. Re-power the SRG-4400
“Limited” range of video formats/ standards	Option is not enabled	Contact Ross Video to obtain additional Option Key(s)
GPS/NTP not operational	Option is not enabled	<ul style="list-style-type: none"> • Ensure Option Key has been entered for applicable option • Contact Ross Video to obtain additional Option Key(s)

Equipment Checklist

Routine maintenance to this Ross Video product is not required. In the event of problems with your SRG-4400, the following basic troubleshooting checklist may help identify the source of the problem. If the SRG-4400 still does not appear to be working properly after checking all possible causes, please contact your Ross Video products distributor, or the Technical Support department at the numbers listed under the “**Contact Us**” section.

- 1. Visual Review** — Performing a quick visual check may reveal many problems, such as connectors not properly seated or loose cables. Check the card, the frame, and any associated peripheral equipment for signs of trouble.
- 2. Power Check** — Verify the power indicator LED for the presence of power. If the power LED is not illuminated, verify that the power cable is connected to a power source and that power is available at the power main. Confirm that the power supplies are fully seated in their slots. If the power LED is still not illuminated, replace the power supply with one that is verified to work.
- 3. Input Signal Status** — Verify that source equipment is operating correctly and that a valid signal is being supplied.
- 4. Output Signal Path** — Verify that destination equipment is operating correctly and receiving a valid signal.
- 5. Unit Exchange** — Exchanging a suspect unit with a unit that is known to be working correctly is an efficient method for localizing problems to individual units.

Contacting Ross Video Technical Support

If your problem is not resolved after following these checks / actions, the fault is likely to be related to a mechanical or electrical component failure. Contact Ross Video for further assistance.

Specifications

In This Chapter

This chapter lists the electrical, mechanical, and environmental characteristics, as well as the national and international standards to which the SRG-4400 complies. Note that specifications are subject to change without notice.

The following topics are discussed:

- General Characteristics
- Reference Specifications
- Analog Video Outputs
- Serial Digital Interface
- Audio Specifications
- LTC Outputs
- Programmable Pulse Unbalanced Outputs
- Communication Interfaces
- Ethernet Interface
- AC Power Source
- Physical Specifications

General Characteristics

All listed specifications are guaranteed unless labeled with “Typical”. Typical specifications are provided for your convenience, but are not guaranteed.

Performance Conditions

The electrical characteristics listed on the following pages are valid under the following conditions:

- The SRG-4400 must be in an environment where the temperature, altitude, humidity, and vibration conditions are within the operating limits described in the section “**Frequency Reference Inputs**” on page 7-3.
- The SRG-4400 must have a warm-up period of at least 20 minutes.
- The SRG-4400 must have been calibrated and adjusted at an ambient temperature between +20°C and +30°C at an altitude of less than 2000m.
- The following label is used to indicated the altitude limitation.



Reference Specifications

Video Reference Inputs

Table 7.1 Video Reference Inputs

Category	Performance Requirement		Reference Information
Input Connector Type	2 x 75ohm BNC (loop through)		
Input Return Loss	>40dB to 5MHz		
Inputs	<ul style="list-style-type: none"> • NTSC Black Burst • 525 Sync • PAL Black Burst • 625 Sync 		
Input Requirements	Amplitude	-6dB to +6dB	
	S/N Ratio	>40dB	
	ScH Phase	±20°	
Pull-in Range	±50ppm		
Jitter	Burst	<0.5°	
	Sync	<1ns	
Genlock Time Offset Range	Range	Full color range	
	Resolution	<0.5 degree of sub-carrier	

Frequency Reference Inputs

Table 7.2 Frequency Reference Inputs

Category	Performance Requirement		Reference Information
Input Connector Type	1 x 50ohm BNC (terminating)		
Input Return Loss	>30dB to 10MHz		
Inputs	10MHz continuous wave		
Input Requirements	Amplitude	1Vp-p (nominal) 2.5Vp-p (maximum)	For 1Vp-p input, Signal Detector has a 0 to -18dB range
	S/N Ratio	>40dB	

GPS Receiver Antenna Input

Table 7.3 GPS Receiver Antenna Input

Category	Performance Requirement	Reference Information
Input Connector Type	1 x 50ohm SMB Jack (terminating)	
Input Return Loss	>8dB @ 1575MHz	
Antenna Voltage	+5.0V \pm 5%	Sourced by the SPG
Antenna Current	Internally limited to 50mA	Source by the SPG
Type	GPS L1 Frequency (1575.42MHz) C/A Code	12 channels
Time stamp accuracy	\leq 150ns to GPS/UTC	

Frequency Reference Outputs

Table 7.4 Frequency Reference Outputs

Category	Performance Requirement	Reference Information
Output Connector Type	1 x BNC	
Output Impedance and Required Termination	50ohm	
Signal Amplitude	1.0V \pm 10%	
Rise and Fall Time	5ns > Rise/Fall <44ns	10% to 90%
Jitter	8ns	Typically 2ns
Outputs	10MHz continuous wave	

1Hz Frequency Reference Output

Table 7.5 1Hz Frequency Reference Output

Category	Performance Requirement	Reference Information
Output Connector Type	1 x BNC	
Output Impedance and Required Termination	75ohm	
Signal Amplitude	3.3V \pm 10%	TTL CMOS compatible
Rise and Fall Time	5ns > Rise/Fall <44ns	10% to 90%
Jitter	8ns	Typically 2ns
Output	1Hz \pm 5ppm	

Analog Video Outputs

Table 7.6 Analog Video Outputs

Category	Performance Requirement		Reference Information
Output Connector Type	75ohm BNC		
Number of Outputs	2 BNCs — Composite Pattern Output		10 BNCs in total
	2 BNCs — Composite Black Burst Output		
	2 BNCs — Tri-Black 2 Output		
	2 BNCs — Tri-Black 3 Output		
	2 BNCs — Tri-Black 4 Output		
Output Impedance	75ohm		
Return Loss	>30dB to 5MHz		
Formats	NTSC-M (with Setup) SMPTE-170M		See notes on field blanking
	NTSC-J (no Setup) SMPTE-170M		
	PAL CCIR-656 ITU-R BT 1700-1 (PAL-B)		
	Tri-Sync SMPTE-274M		Tri-Sync available only on Tri-Black 2, Tri-Black 3, and Tri-Black 4 outputs
Burst Amplitude Accuracy	±5%	Typically ±2%	
Burst Frequency Accuracy	±1Hz	Typically ±0.25Hz	
Burst Frequency Long Term	<1ppm/year		
Sync Amplitude Accuracy	±3%		Typically ±1%
SCH Phase Accuracy	±5°		
Blanking Level	±50mV		Typically ±10mV
Timing Offset	Range	Full color frame	
	Resolution NTSC and PAL	<0.5 degree of sub-carrier	
	Resolution Tri-Sync	<1/54MHz	
Monochrome Bitmap Logo or ID Text	Maximum 26 characters in each of 3 rows		Animation effects
	Gray Scale	8 level	

Notes on Field Blanking

Composite Output: NTSM-M, NTSC-J

- Field 1 lines 1 - 20 inclusive are blanked i.e. there is no pattern information but there may be VITC etc.

- Field 2 lines 263 - 283 inclusive are blanked i.e. there is no pattern information but there may be VITC etc.
 - › Line 263 and Line 283 are specified as active half lines in *SMPTE RS170M* but they are fully blanked in this SRG-4400.

Composite Output: PAL

- Field 1 lines 623 - 23 inclusive are blanked i.e. there is no pattern information but there may be VITC etc.
 - › Line 623 and Line 23 are specified as active half lines in *CCIR-624* but they are fully blanked in this SRG-4400.
- Field 2 lines 311 - 336 inclusive are blanked i.e. there is no pattern information but there may be VITC etc.

SDI Output: NTSC-M, NTSC-J

- *SMPTE 125M* says 1 - 20 inclusive and 264 - 282 inclusive are blanked.
- *CCIR 656-4* says 1 - 20 inclusive and 264 - 282 inclusive are blanked.

SDI Output: PAL

- *EBU tech3267* says 624 - 22 inclusive and 311 - 335 inclusive are blanked.
- *CCIR 656-4* says 624 - 22 inclusive and 311 - 335 inclusive are blanked.

Serial Digital Interface

Table 7.7 Serial Digital Interface

Category	Performance Requirement		Reference Information
Output Connector Type	75ohm BNC		
Number of Outputs	2 BNCs — SDI 1 Pattern Output		8 BNCs in total
	2 BNCs — SDI 1 Black Output		
	2 BNCs — SDI 2 Pattern Output		
	2 BNCs — SDI 2 Black Output		
Output Impedance	75ohm		
Return Loss	>15dB to 270MHz		
	>15dB to 1.5GHz		
	>10dB to 3GHz		
Formats^a	525i/625i (270Mbps)		
	720p (1.5Gbps)		
	1035i (1.5Gbps)		
	1080i (1.5Gbps)		
	1080p (3Gbps)		
Signal Amplitude	800mV ±10%		
Rise and Fall Time	270Mbps	≤600ps ±15ps	<1000ps ±500ps
	1.5Gbps	≤130ps ±20ps	<270ps ±50ps
	3Gbps	≤120ps ±15ps	<135ps ±25ps
Jitter	270Mbps	Timing: ≤0.16UI	<0.2UI @ 10Hz
		Alignment: ≤0.10UI	<0.2UI @ 1KHz
	1.5Gbps	Timing: ≤0.30UI	<1.0UI @ 10Hz
		Alignment: ≤0.07UI	<0.2UI @ 100KHz
	3Gbps	Timing: ≤0.65UI	<2.0UI @ 10Hz
		Alignment: ≤0.15UI	<0.3UI @ 100KHz
Timing Offset	Range	Full color frame	
	Resolution 270Mbps	<1/54.00MHz	
	Resolution 1.5Gbps	<1/74.25MHz	
	Resolution 3Gbps	<1/148.50MHz	
Monochrome Bitmap Logo or ID Text	Maximum 30 characters in each row of 3 rows		Animation effects
	Gray Scale	4 level	

Table 7.7 Serial Digital Interface

Category	Performance Requirement		Reference Information
Embedded Audio	270Mbps	Number of channels: 4 per SDI	
	1.5Gbps	Number of channels: 16 per SDI	
	3Gbps	Number of channels: 16 per SDI	
	Frequency	20Hz-20KHz	1Hz resolution
	Amplitude	Silence and -78dBFS to 0dBFS	1dB resolution
	Pre-emphasis	None	
	Interruption	Programmable	1 second, 3 second, EBU TECH 3304, Glits, Blits
Quantized Resolution	270Mbps	20bits	
	1.5Gbps, 3Gbps	24bits	

- a. 270Mbps SDI (SMPTE 259M), 1.5Gbps SDI (SMPTE 292M), 3Gbps (SMPTE 424M)

Audio Specifications

AES/EBU Audio Unbalanced Outputs

Table 7.8 AES/EBU Audio Unbalanced Outputs

Category	Performance Requirement		Reference Information
Output Connector Type	3 x BNC		
Number of Outputs	2 x unbalanced Audio on BNC		AES-3 AES-3id
	1 x unbalanced DARS on BNC		DARS is indicated as “non-PCM audio” and “20bit” and “Grade 1 reference signal”
Output Impedance and Required Termination	75ohm		
Signal Amplitude	1V ±10%		
Rise and Fall Time	5ns > Rise/Fall < 44ns		10% to 90%
Jitter	8ns		Typically 2ns
Audio Parameters	Frequency	20Hz-20kHz	Steps of <1Hz
	Amplitude	Silence and -78dBFS to 0dBFS	1dB resolution
	Pre-emphasis	None	
	Interruption	Programmable	1 second, 3 second, EBU TECH 3304, Glits, Blits
Quantized Resolution	24bits		

AES/EBU Audio Balanced Outputs

Table 7.9 AES/EBU Audio Balanced Output

Category	Performance Requirement		Reference Information
Output Connector Type	Molex® MicroClasp™ 2mm, 30-pin		Shared with Analog Audio and LTC
Number of Outputs	Up to 8 Balanced AES Outputs		AES-3
	1 x DARS		AES-11 DARS is indicated as “non-PCM audio” and “20bit” and “Grade 1 reference signal”
Output Impedance and Required Termination	Differential Balanced Line Driver Output. The signal must be terminated at the receiver.		Use terminating resistor
Signal Amplitude	5V ±10% Balanced		

Table 7.9 AES/EBU Audio Balanced Output

Category	Performance Requirement		Reference Information
Rise and Fall Time	5ns > Rise/Fall <44ns		10% to 90%
Jitter	8ns		Typically 2ns
Audio Parameters	Frequency	20Hz to 20KHz	Steps of 1Hz
	Amplitude	-60dBFS to 0dBFS	1dB resolution
	Pre-emphasis	None	
	Interruption	Programmable	1 second, 3 second, EBU TECH 3304, Glits, Blits
Quantized Resolution	24bits		

Analog Audio Outputs

Table 7.10 Analog Audio Outputs

Category	Performance Requirement		Reference Information
Output Connector Type	Molex® MicroClasp™ 2mm, 30-pin		Shared with AES/EBU Audio and LTC
Number of Outputs	2 x Balanced		1 x stereo balanced pair
Output Impedance	50ohm ±5%		
Termination Impedance	600ohm ±5%		Calibrated with 600ohm ±1%
Audio Parameters	Frequency	1Hz to 20KHz	Steps of <1Hz
	Amplitude	Silence and -60dBm to +18dBm	1dB resolution
	Interruption	Programmable	1 second, 3 second, EBU TECH 3304, Glits, Blits
	Harmonic Distortion	<-50dB	Measured at 1KHz
DAC Resolution	18bits		

LTC Outputs

Table 7.11 1LTC Outputs

Category	Performance Requirement	Reference Information
Output Connector Type	Molex® MicroClasp™ 2mm, 30-pin	Shared with Analog Audio and AES/EBU Audio
Number of Outputs	Up to 8 Balanced LTC Outputs	
Output Impedance and Required Termination	Differential Balanced Line Driver Output The signal must be terminated at the receiver.	Use terminating resistor
Signal Amplitude	5V ±10% Balanced	
Rise and Fall Time	5ns > Rise/Fall < 44ns	10% to 90%
Type	LTC SMPTE-12M	

Programmable Pulse Unbalanced Outputs

Table 7.12 Programmable Pulse Unbalanced Outputs

Category	Performance Requirement	Reference Information
Output Connector Type	3 x BNC	
Output Impedance and Required Termination	75ohm	
Signal Amplitude	3.3V ±10%	CMOS compatible
Rise and Fall Time	5ns > Rise/Fall <44ns	10% to 90%
Jitter	8ns	Typically 2ns
Pulse Type Individually Programmable on each BNC	Mixed Sync	Video pulses are derived from the Black 1 output. Audio is derived from the Composite video AES 1-8 generator and conforms to AES-3 and AES-11. Wordclock conforms to AES-11 Annex B
	Mixed Blanking	
	Burst Gate	
	PAL Square	
	Line Drive	
	Field Drive	
	F1 / L7 or F1 / L10	
	6Hz / 30Hz	
	6Hz / 29.97Hz	
	Word Clock 48KHz AES-11 Annex B	
	Word Clock 44.1KHz AES-11 Annex B	

Communication Interfaces

One connector is shared between the GPI, and RS-232 interfaces.



Note — *This port is not implemented.*

General Purpose Interface (GPI)

Table 7.13 GPI Specifications

Category	Performance Requirement	Reference Information
Connector Type	Molex® MicroClasp™ 2mm, 30-pin	Shared with RS-232 and ONAIR
Outputs	Pin 7: GP Output 1 Open Collector	
	Pin 8: GP Output 2 Open Collector	
	Pin 1: GND	
	Pin 10: GND	
Output Level	<0.4V	Measured at 100mA sink
Inputs	Pin 5: GP Input 1	
	Pin 6: GP Input 2	
Input Level	TTL compatible	Pulled up to 3.3V with 47kohm

RS-232 Interface

Table 7.14 RS-232 Interface

Category	Performance Requirement	Reference Information
Connector Type	Molex® MicroClasp™ 2mm, 30-pin	Shared with GPI and ONAIR
Outputs	Pin 2: GND	
	Pin 4: RS232 TX	
Inputs	Pin 3: RS232 RX	

Ethernet Interface

Table 7.15 Ethernet Interface

Category	Performance Requirement	Reference Information
Connector Type	1 x RJ45 - 8P8C	
IEEE Standards Compliance	IEEE 802.31-1990	10BASE-T
	IEEE 802.3u-1995	100BASE-TX
	IEEE 1588-2008	Precision Time Protocol

AC Power Source

Table 7.16 AC Power Source

Category	Performance Requirement		Reference Information
Operational Voltage Range	120 to 230VAC, 50-60Hz		
Absolute Limits Voltage Range	90 to 264VAC, 47-63Hz		
Fuse	5mmx20mm Anti-surge 2A 250V Fuse identification marking T2A H250V		IEC 60127-2
Operational AC Current	Each PSU	<130mA @ 230VAC	
		<200mA @ 120VAC	
Surge AC Current	Each PSU	<40A @ 230VAC	
		<20A @ 120VAC	
Power Consumption	Dual PSU	46VA	≈ 21 Watts - calculated
Switched Mode Power Supply	Single output, AC-DC, 65W 12VDC / 5.4A output		XP Power ECS65US12

Physical Specifications

Clearance

Table 7.17 Clearance Requirements

Category	Performance Requirement		Reference Information
Clearance	Side	50mm (2.00")	
	Rear	75mm (3.00")	

Mechanical Characteristics

Table 7.18 Mechanical Specifications

Category	Performance Requirement		Reference Information
Dimensions	Height	43.5mm (1.71")	
	Width	482.5mm (19.00")	
	Depth	405mm (15.95")	
	Net Weight	5.85kg (12.9lb)	

Environment Characteristics

Table 7.19 Environment Characteristics

Category	Performance Requirement	Reference Information
Temperature	Operating	0°C to +40°C
	Non-operating	-20°C to +60°C
Relative Humidity	Operating	20% to 80% relative humidity (%RH) at up to +40°C, non-condensing
	Non-operating	5% to 90% relative humidity (%RH) at up to +60°C, non-condensing
Altitude	Operating	To 2,000m (6,561ft)
	Non-operating	To 12,192m (40,000ft)
Vibration	Operating	2.65m/s ² (0.27Grms), 5Hz to 500Hz, 10 minutes per axis, three axes
	Non-operating	22.3m/s ² (2.28Grms), 5Hz to 500Hz, 10 minutes per axes, three axes
Shock	Non-operating	294m/s ² (30G), half-sine, 11ms duration

Certifications and Compliances

In This Chapter

The following topics are discussed:

- Certifications and Compliances

Certifications and Compliances

Table 8.1 EC Declaration of Conformity - EMC

Category	Standards or Description	
EC Declaration of Conformity - EMC	Meets the intent of Directive 89/336/EEC for Electromagnetic Compatibility. Compliance was demonstrated to the following specifications as listed in the Official Journal of the European Communities.	
	EN55103	
	Environmental	E2-commercial and light industrial
	Part 1 Emission	EN55022 Class B radiated and conducted emissions
		EN55103-1, Annex A Radiated magnetic field emissions
		EN55103-1, Annex B Inrush current; I peak=14.6 amps
	Part 2 Immunity	IEC61000-4-2 Electrostatic discharge immunity
		IEC61000-4-3 RF electromagnetic field immunity
		IEC61000-4-4 Electrical fast transient/burst immunity
		IEC61000-4-5 Power line surge immunity
		IEC61000-4-6 Conducted RF immunity
IEC61000-4-11 Voltage dips and interruptions immunity		
EN55103-2, Annex A Radiated magnetic field immunity		
EN61000-3-2 — AC power line harmonic current emissions		
EN61000-3-3 — Voltage changes, fluctuations, and flicker		
EC Declaration of Conformity - Safety	Compliance was demonstrated to the following specification as listed in the Official Journal of the European Union: <ul style="list-style-type: none"> • IEC 60950-1/A1:2009 • EN60950-1/A12:2011 — Safety requirements for electrical equipment for measurement, control, and laboratory use. 	
Australia/New Zealand Declaration of Conformity -EMC	Complies with the EMC Framework, demonstrated per Emission Standard AS/NZS 2064 (Industrial, Scientific, and Medical Equipment).	
Safety	Complies with the following safety standards: <ul style="list-style-type: none"> UL 60950-1 CAN/CSA C22.2 No. 1010.1 IEC 60950-1/A1:2009 	

Table 8.1 EC Declaration of Conformity - EMC

Category	Standards or Description	
Installation (over voltage) Category	<p>Terminals on this product may have different installation (over-voltage) category designations.</p> <p>The installation categories are:</p> <ul style="list-style-type: none"> • CAT III — Distribution-level mains (usually permanently connected). Equipment at this level is typically in a fixed industrial location. • CAT II — Local-level mains (wall sockets). Equipment at this level includes appliances, portable tools, and similar products. Equipment is usually cord-connected. • CAT I — Secondary (signal level) or battery operated circuits of electronic equipment. 	
Pollution Degree	<p>A measure of the contaminants that could occur in the environment around and within a product. Typically the internal environment inside a product is considered to be the same as the external. Products should be used only in the environment for which they are rated.</p>	
	Pollution Degree 2	<p>Normally only dry, non-conductive pollution occurs. Occasionally, a temporary conductivity that is caused by condensation must be expected. This location is a typical office/home environment. Temporary condensation occurs only when the product is out of service.</p>
Manufacturing	<p>All assemblies manufactured in an ISO9001:2008 registered facility. Steel is 18swg (1.2mm) thickness CR4GP (Cold Reduced Mill Finish General Purpose) to BS 1449 Plating is zinc and clear passivated to BS EN 12329:2000 FE//ZN8//A (FE = Steel, ZN8 = 8 mic minimum zinc deposit, A = clear passivation).</p>	
	<p>All assemblies manufactured in accordance to IPC-A-610E class 2 suitability standard.</p>	
	<p>All assemblies manufactured in accordance to ISO14001:2004 environmental standard.</p>	
IEC Characteristics	Equipment Type: Test and Measuring	<ul style="list-style-type: none"> • Installation Category II (Single-phase, receptacle -connected loads) • Pollution Degree 2 (Normally only non-conductive pollution occurs) • Safety Class I (Grounded product) • Temperature 5°C to 40°C

Connector Pinouts

In This Chapter

This chapter lists the pinouts of various multi-way connectors available on the rear panel of the SRG-4400. Note that specifications are subject to change without notice.

The following topics are discussed:

- Balanced Audio/AES/LTC Connector
- GPI/RS232 Connector

Balanced Audio/AES/LTC Connector

Table 9.1 provides the balanced pinouts (Molex® 2mm MicroClasp™ series plug (male)) for the Audio/AES/LTC connector. Looking at the rear of the unit, the bottom row includes the Odd numbered pins (e.g. LTC2+) and the top row includes the even numbered pins (e.g. LTC2-). Refer to **Table 7.10**, **Table 7.9**, and **Table 7.11** for technical details regarding this connector.

Table 9.1 *Balanced Audio/AES/LTC Pinouts*

Pin	Signal/Function
1	Ground
2	Ground
3	LTC2+
4	LTC2-
5	LTC1+
6	LTC1-
7	LTC4+ / AES8+
8	LTC4- / AES8-
9	LTC3+ / AES7+
10	LTC3- / AES7-
11	AES6+
12	AES6-
13	AES5+
14	AES5-
15	AES4+
16	AES4-
17	AES3+
18	AES3-
19	AES2+
20	AES2-
21	AES1+
22	AES1-
23	DARS+
24	DARS-
25	AUD1+ Left
26	AUD1- Left
27	AUD2+ Right
28	AUD2- Right
29	Ground
30	Ground

Pin Views of Connectors

Connectors are Molex™ Micro Clasp 2mm series.

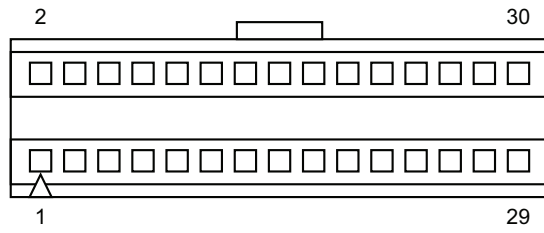
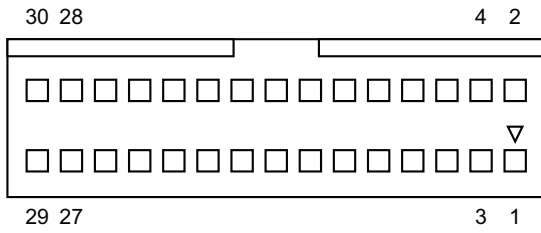

Figure 9.1 Chassis Connectors (Molex #55959-3030) **Figure 9.2** Mating Connectors (Molex #51353-3000)

GPI/RS232 Connector



Note — *This port is not implemented.*

Connector Pinouts

Table 9.2 provides the pinouts (Molex® 2mm MicroClasp™ series plug (male)) for the GPI/RS232 connector. Refer to **Table 7.13** and **Table 7.14** and for technical details regarding this connector.

Table 9.2 GPI/RS232 Connector

Pin	Signal/Function
1	Ground
2	Ground
3	RS232 - RX
4	RS232 - TX
5	GP Input 1 - TTL compatible
6	GP Input 2 - TTL compatible
7	GP Output 1 - Open Collector
8	GP Output 2 - Open Collector
9	ONAIR - Open Collector
10	Ground

Breakout Cable

Table 9.3 provides the pinouts for the GPI/RS232 breakout cable and can be used for the following connector types:

- 10-pin connector Molex® 2mm MicroClasp™ series socket (female)
- 9-pin connector, D-type, plug (male)

Table 9.3 GPI/RS232 Breakout Cable

10-Pin Micro-clasp	Signal/Function	D9 Plug (Male)
1	Ground	n/c
2	Ground	5
3	RS232 - RX	2
4	RS232 - TX	3
5	GP Input 1 - TTL compatible	n/c
6	GP Input 2 - TTL compatible	n/c
7	GP Output 1 - Open Collector	n/c
8	GP Output 2 - Open Collector	n/c
9	ONAIR - Open Collector	9
10	Ground	

Pin Views of Chassis Connectors

Connectors are Molex™ Micro Clasp 2mm series.

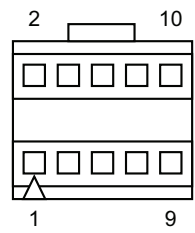
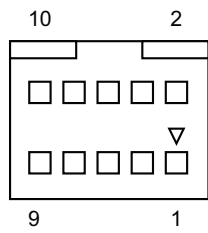

Figure 9.3 Chassis Connectors (Molex #55959-1030) **Figure 9.4** Mating Connectors (Molex #51353-1000)

Characters for Idents

In This Chapter

The following topics are discussed:

- Notes about Compatibility Characters
- Characters Available

Notes about Compatibility Characters

- Characters in Idents come from an intersection list of the first 256 characters from Unicode and the allowable characters in XML 1.1.
- Document authors are encouraged to avoid “compatibility characters”, as defined in Unicode.
- The characters defined in the following ranges are also discouraged. They are either control characters or permanently undefined Unicode characters.

[#x1-#x8], [#xB-#xC], [#xE-#x1F], [#x7F-#x84], [#x86-#x9F],

[#xFDD0-#xFDDF],

[#x1FFFE-#x1FFFF], [#x2FFFE-#x2FFFF], [#x3FFFE-#x3FFFF],

[#x4FFFE-#x4FFFF], [#x5FFFE-#x5FFFF], [#x6FFFE-#x6FFFF],

[#x7FFFE-#x7FFFF], [#x8FFFE-#x8FFFF], [#x9FFFE-#x9FFFF],

[#xAFFFE-#xAFFFF], [#xBFFFE-#xBFFFF], [#xCFFFE-#xCFFFF],

[#xDFFFE-#xDFFFF], [#xEFFFE-#xEFFFF], [#xFFFE-#xFFFF],

[#x10FFFE-#x10FFFF]

- XML 1.1 explicitly excludes the following characters:

[0x01-0x08], [0x0b-0x0c], [0x0E-0x1F], [0x7f-0x84], [0x86-0x9f]

Characters Available

Table 10.1 lists the supported characters. Unsupported characters are set in grey. Generally, if an unsupported character is detected, it will be replaced with the 'space' character 0x20.

Table 10.1 Available Characters for Idents 000-007

	000	001	002	003	004	005	006	007
0	NUL	DLE	SP	0	@	P	'	p
1	SOH	DC1	!	1	A	Q	a	q
2	STX	DC2	“	2	B	R	b	r
3	ETX	DC3	#	3	C	S	c	s
4	EOT	DC4	\$	4	D	T	d	t
5	ENQ	NAK	%	5	E	U	e	u
6	ACK	SYN	&	6	F	V	f	v
7	BEL	ETB	'	7	G	W	g	w
8	BS	CAN	(8	H	X	h	x
9	HT	EM)	9	I	Y	i	y
A	LF	SUB	*	:	J	Z	j	z
B	VT	ESC	+	;	K	[k	{
C	FF	FS	,	<	L	\	l	
D	CR	GS	-	=	M]	m	}
E	SO	RS	.	>	N	^	n	~
F	SI	US	/	?	O	_	o	DEL

Table 10.2 Available Characters for Idents 008-00F

	008	009	00A	00B	00C	00D	00E	00F
0	XXX	DCS	NB SP	°	À	Ð	à	ð
1	XXX	PU1	ı	±	Á	Ñ	á	ñ
2	BPH	PU2	¢	²	Â	Ò	â	ò
3	NBH	STS	£	³	Ã	Ó	ã	ó
4	IND	CCH	¤	´	Ä	Ô	ä	ô
5	NEL	MW	¥	µ	Å	Õ	å	õ
6	SSA	SPA		¶	Æ	Ö	æ	ö
7	ESA	EPA	§	·	Ç	×	ç	÷
8	HTS	SOS	¨	,	È	Ø	è	ø
9	HTJ	XXX	©	¹	É	Ù	é	ù
A	VTS	SCI	ª	º	Ê	Ú	ê	ú
B	PLQ	CSI	«	»	Ë	Û	ë	û
C	PLU	ST	¬	¼	Ì	Ü	ì	ü
D	RI	OSC	SHY	½	Í	Ý	í	ý
E	SS2	PM	®	¾	Î	Þ	î	þ
F	SS3	APC	—	¿	Ï	ß	ï	ÿ

Test Patterns

In This Chapter

This chapter provides an overview of the test patterns available for the SRG-4400. The patterns are stored in a pattern file in FLASH memory. The pattern file can be updated via the Ethernet interface. A slightly different set of test patterns is available for each signal format.

The following topics are discussed:

- 525i Test Patterns
- 625i Test Patterns
- 720p Test Patterns
- 1035i Test Patterns
- 1080i and 1080PsF Test Patterns
- 1080p Test Patterns

525i Test Patterns

"black	",	//0
"white100	",	//1
"yellow100	",	//2
"cyan100	",	//3
"green100	",	//4
"magenta100	",	//5
"red100	",	//6
"blue100	",	//7
"rp219_000_p2white100_p3Black	",	//8
"rp219_001_p2white075_p3Black	",	//9
"rp219_002_p2nI_p3Black	",	//10
"rp219_003_p2pI_p3pQ	",	//11
"16x12hardgrille_blacksquare	",	//12
"16x12softgrille_blacksquare	",	//13
"16x12hardgrille_white050square	",	//14
"16x12softgrille_white050square	",	//15
"16x9hardgrille_blacksquare	",	//16
"16x9softgrille_blacksquare	",	//17
"16x9hardgrille_white050square	",	//18
"16x9softgrille_white050square	",	//19
"bar100_9	",	//20
"bar100_9_red100	",	//21
"bar100_8	",	//22
"bar100_8_red100	",	//23
"bar095_9	",	//24
"bar095_9_red095	",	//25
"bar095_8	",	//26
"bar095_8_red095	",	//27
"bar075_9	",	//28
"bar075_9_red075	",	//29
"bar075_8	",	//30
"bar075_8_red075	",	//31
"barebu_9	",	//32
"barebu_9_red075	",	//33
"barebu_8	",	//34
"barebu_8_red075	",	//35
"barsmpte	",	//36
"pathological_type1	",	//37

```
"pathological_type2           ", //38
"multiburst_full_mono        ", //39
"multiburst_half_mono        ", //40
"multiburst_Half_Luma_Full_Chro ", //41
"multiburst_half_color       ", //42
"sweep_full_mono             ", //43
"sweep_half_mono             ", //44
"sweep_Half_Luma_Full_Chroma ", //45
"sweep_half_color           ", //46
"100%_valid_ramps_1         ", //47
"EBU3305                     ", //48
"Pulses                       ", //49
"full_frame_picture_type1    ", //50
"full_frame_picture_type2    ", //51
```

625i Test Patterns

"black	",	//0
"white100	",	//1
"yellow100	",	//2
"cyan100	",	//3
"green100	",	//4
"magenta100	",	//5
"red100	",	//6
"blue100	",	//7
"rp219_000_p2white100_p3Black	",	//8
"rp219_001_p2white075_p3Black	",	//9
"rp219_002_p2nI_p3Black	",	//10
"rp219_003_p2pI_p3pQ	",	//11
"16x12hardgrille_blacksquare	",	//12
"16x12softgrille_blacksquare	",	//13
"16x12hardgrille_white050square	",	//14
"16x12softgrille_white050square	",	//15
"16x9hardgrille_blacksquare	",	//16
"16x9softgrille_blacksquare	",	//17
"16x9hardgrille_white050square	",	//18
"16x9softgrille_white050square	",	//19
"bar100_9	",	//20
"bar100_9_red100	",	//21
"bar100_8	",	//22
"bar100_8_red100	",	//23
"bar095_9	",	//24
"bar095_9_red095	",	//25
"bar095_8	",	//26
"bar095_8_red095	",	//27
"bar075_9	",	//28
"bar075_9_red075	",	//29
"bar075_8	",	//30
"bar075_8_red075	",	//31
"barebu_9	",	//32
"barebu_9_red075	",	//33
"barebu_8	",	//34
"barebu_8_red075	",	//35
"barsmpte	",	//36
"pathological_type1	",	//37

"pathological_type2	",	//38
"multiburst_full_mono	",	//39
"multiburst_half_mono	",	//40
"multiburst_Half_Luma_Full_Chro	",	//41
"multiburst_half_color	",	//42
"sweep_full_mono	",	//43
"sweep_half_mono	",	//44
"sweep_Half_Luma_Full_Chroma	",	//45
"sweep_half_color	",	//46
"100%_valid_ramps_1	",	//47
"EBU3305	",	//48
"Pulses	",	//49
"full_frame_picture_type1	",	//50
"full_frame_picture_type2	",	//51

720p Test Patterns

"black	",	//0
"white100	",	//1
"yellow100	",	//2
"cyan100	",	//3
"green100	",	//4
"magenta100	",	//5
"red100	",	//6
"blue100	",	//7
"rp219_000_p2white100_p3Black	",	//8
"rp219_001_p2white075_p3Black	",	//9
"rp219_002_p2nI_p3Black	",	//10
"rp219_003_p2pI_p3pQ	",	//11
"16x9hardgrille_blacksquare	",	//12
"16x9softgrille_blacksquare	",	//13
"16x9hardgrille_white050square	",	//14
"16x9softgrille_white050square	",	//15
"bar100_9	",	//16
"bar100_9_red100	",	//17
"bar100_8	",	//18
"bar100_8_red100	",	//19
"bar095_9	",	//20
"bar095_9_red095	",	//21
"bar095_8	",	//22
"bar095_8_red095	",	//23
"bar075_9	",	//24
"bar075_9_red075	",	//25
"bar075_8	",	//26
"bar075_8_red075	",	//27
"barebu_9	",	//28
"barebu_9_red075	",	//29
"barebu_8	",	//30
"barebu_8_red075	",	//31
"pathological_frame0	",	//32
"pathological_frame1	",	//33
"multiburst_full_mono	",	//34
"multiburst_half_mono	",	//35
"multiburst_Half_Luma_Full_Chro	",	//36
"multiburst_half_color	",	//37

```
"sweep_full_mono           ", //38
"sweep_half_mono           ", //39
"sweep_Half_Luma_Full_Chroma ", //40
"sweep_half_color          ", //41
"100%_valid_ramps_1       ", //42
"100%_valid_ramps_2       ", //43
"7_T_Pulses                ", //44
```

1035i Test Patterns

"black	",	//0
"white100	",	//1
"yellow100	",	//2
"cyan100	",	//3
"green100	",	//4
"magenta100	",	//5
"red100	",	//6
"blue100	",	//7
"rp219_000_p2white100_p3Black	",	//8
"rp219_001_p2white075_p3Black	",	//9
"rp219_002_p2nI_p3Black	",	//10
"rp219_003_p2pI_p3pQ	",	//11
"16x9hardgrille_blacksquare	",	//12
"16x9softgrille_blacksquare	",	//13
"16x9hardgrille_white050square	",	//14
"16x9softgrille_white050square	",	//15
"bar100_9	",	//16
"bar100_9_red100	",	//17
"bar100_8	",	//18
"bar100_8_red100	",	//19
"bar095_9	",	//20
"bar095_9_red095	",	//21
"bar095_8	",	//22
"bar095_8_red095	",	//23
"bar075_9	",	//24
"bar075_9_red075	",	//25
"bar075_8	",	//26
"bar075_8_red075	",	//27
"barebu_9	",	//28
"barebu_9_red075	",	//29
"barebu_8	",	//30
"barebu_8_red075	",	//31
"pathological_frame0	",	//32
"pathological_frame1	",	//33
"multiburst_full_mono	",	//34
"multiburst_half_mono	",	//35
"multiburst_Half_Luma_Full_Chro	",	//36
"multiburst_half_color	",	//37

```
"sweep_full_mono           ", //38
"sweep_half_mono          ", //39
"sweep_Half_Luma_Full_Chroma ", //40
"sweep_half_color         ", //41
"100%_valid_ramps_1      ", //42
"100%_valid_ramps_2     ", //43
"7_T_Pulses              ", //44
```

1080i and 1080PsF Test Patterns

"black	",	//0
"white100	",	//1
"yellow100	",	//2
"cyan100	",	//3
"green100	",	//4
"magenta100	",	//5
"red100	",	//6
"blue100	",	//7
"rp219_000_p2white100_p3Black	",	//8
"rp219_001_p2white075_p3Black	",	//9
"rp219_002_p2nI_p3Black	",	//10
"rp219_003_p2pI_p3pQ	",	//11
"16x9hardgrille_blacksquare	",	//12
"16x9softgrille_blacksquare	",	//13
"16x9hardgrille_white050square	",	//14
"16x9softgrille_white050square	",	//15
"bar100_9	",	//16
"bar100_9_red100	",	//17
"bar100_8	",	//18
"bar100_8_red100	",	//19
"bar095_9	",	//20
"bar095_9_red095	",	//21
"bar095_8	",	//22
"bar095_8_red095	",	//23
"bar075_9	",	//24
"bar075_9_red075	",	//25
"bar075_8	",	//26
"bar075_8_red075	",	//27
"barebu_9	",	//28
"barebu_9_red075	",	//29
"barebu_8	",	//30
"barebu_8_red075	",	//31
"pathological_frame0	",	//32
"pathological_frame1	",	//33
"multiburst_full_mono	",	//34
"multiburst_half_mono	",	//35
"multiburst_Half_Luma_Full_Chro	",	//36
"multiburst_half_color	",	//37

```
"sweep_full_mono           ", //38
"sweep_half_mono           ", //39
"sweep_Half_Luma_Full_Chroma", //40
"sweep_half_color          ", //41
"100%_valid_ramps_1       ", //42
"100%_valid_ramps_2       ", //43
"7_T_Pulses                ", //44
"full_frame_picture_type1  ", //45
"full_frame_picture_type2  ", //46
```

1080p Test Patterns

"black	",	//0
"white100	",	//1
"yellow100	",	//2
"cyan100	",	//3
"green100	",	//4
"magenta100	",	//5
"red100	",	//6
"blue100	",	//7
"rp219_000_p2white100_p3Black	",	//8
"rp219_001_p2white075_p3Black	",	//9
"rp219_002_p2nI_p3Black	",	//10
"rp219_003_p2pI_p3pQ	",	//11
"16x9hardgrille_blacksquare	",	//12
"16x9softgrille_blacksquare	",	//13
"16x9hardgrille_white050square	",	//14
"16x9softgrille_white050square	",	//15
"bar100_9	",	//16
"bar100_9_red100	",	//17
"bar100_8	",	//18
"bar100_8_red100	",	//19
"bar095_9	",	//20
"bar095_9_red095	",	//21
"bar095_8	",	//22
"bar095_8_red095	",	//23
"bar075_9	",	//24
"bar075_9_red075	",	//25
"bar075_8	",	//26
"bar075_8_red075	",	//27
"barebu_9	",	//28
"barebu_9_red075	",	//29
"barebu_8	",	//30
"barebu_8_red075	",	//31
"pathological_frame0	",	//32
"pathological_frame1	",	//33
"multiburst_full_mono	",	//34
"multiburst_half_mono	",	//35
"multiburst_Half_Luma_Full_Chro	",	//36
"multiburst_half_color	",	//37

"sweep_full_mono	",	//38
"sweep_half_mono	",	//39
"sweep_Half_Luma_Full_Chroma	",	//40
"sweep_half_color	",	//41
"100%_valid_ramps_1	",	//42
"100%_valid_ramps_2	",	//43
"7_T_Pulses	",	//44
"full_frame_picture_type1	",	//45
"full_frame_picture_type2	",	//46

Connecting via DashBoard

In This Chapter

This chapter provides information for connecting to the DashBoard client. The DashBoard software and user manual can be downloaded from our website.

The following topics are discussed:

- General Usage
- Accessing the SRG-4400 via DashBoard

General Usage

The SRG-4400 can be remotely controlled over an ethernet link by a DashBoard client.

Before You Begin

Keep the following in mind when using DashBoard to communicate with the SRG-4400:

- The SRG-4400 is always configured as a fixed IPv4 device using the menu system accessible on the front panel.
- The menu structure is **System Setup** menu > **Network** menu.
- The items to be configured are: **IP Address**, **Subnet Mask**, and **Gateway**. Ask your network expert to help set these up.
- The controlling DashBoard client is expected to be on the same subnet as the SRG-4400.

Once a connection is established, a “ping” command can be issued on the computer running the DashBoard client. This is not required by is a useful diagnostic.

- If the ping fails, then the network route is not available. This indicates a basic network architecture failure. Consult a network expert.
- If the ping is successful, then a DashBoard connection should be possible.

Accessing the SRG-4400 via DashBoard

Double-clicking a sub-node displays the corresponding tab in the Device View in the right pane of the DashBoard window.

To access the SRG-4400 via DashBoard

1. Launch the DashBoard application on your computer.
2. Select **+ Add New Connection** to display the **New Connection** dialog.
3. Select **TCP/IP openGear Frame** from the provided list.
4. Click **Next >** to display the **New TCP openGear Frame Connection** dialog.
5. Type the IP address of the SRG-4400 in the **IP Address** field.
6. Type a unique name for the SRG-4400 in the **Display Name** field. This name makes the SRG-4400 easily identifiable in the Tree View.
7. Click **Finish**.
8. Verify that the SRG-4400 is now listed in the Tree View.
9. Double-click the SRG-4400 node in the Tree View to expand the list of sub-nodes. In the provided example, the menus for slot 0 are displayed.

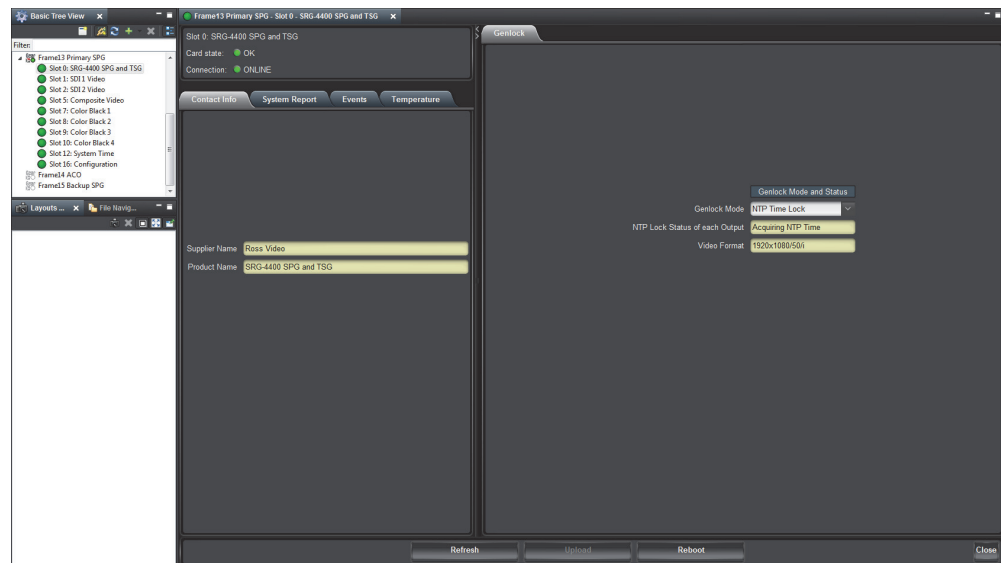

Example of an SRG-4400 in DashBoard

NTP Option

In This Chapter

This chapter provides information on installing the NTP option for your SRG-4400.

The following topics are discussed:

- Overview
- Background Information
- Simplified NTP Flowcharts
- Required Time Corrections

Overview

The SRG-4400 always contains the hardware, software and associated circuitry necessary to allow operation of the NTP Option.

An Option Key is used to enable the NTP Option (refer to the section “**Option Enable Menu**” on page 5-57 for details). No additional externally connected hardware is required as part of the installation. A power cycle may be required to complete the update process.

In order to utilize the NTP Option, simply use an Ethernet cable to connect the SRG-4400 to your local network device (master router or local hub).

Follow the instructions in the section “**Network Menu**” on page 5-48 and “**NTP Menus**” on page 5-50 to configure the Network and NTP systems with your required parameters.

Background Information

A good source of reference time is the Network Time Protocol available on most commercial Ethernet networks. Note: No frequency or phase can be accurately inferred from the NTP system.

The SRG-4400 NTP system can be configured in two ways:

- NTP Server where the SRG-4400 acts as the device from which other NTP clients request time.
- NTP Client where the SRG-4400 requests time from a NTP Server.

NTP Server

When configured as an NTP Server, the SRG-4400 responds to requests from “Clients” and replies with a “time-stamp”. It is up to the Client to decide on the validity and accuracy of this time. An NTP system may be able to resolve time in the region of hundreds of milliseconds. Do not expect anything better!

NTP Client

As the SRG-4400 is powered, the NTP Client begins requesting time from the designated remote NTP server. The NTP Client will keep searching for a time until it gets one.

The NTP operational parameters can be monitored in the LCD menu, and on the Dashboard remote control program.

Default Settings

The default settings of the NTP system are as follows:

- SPG IP address 192.168.001.044
- SPG IP mask 255.255.255.000
- SPG IP Gateway 192.168.001.254
- NTP Server IP address 139.143.005.030
- Remote NTP Server IP address 139.143.005.030.

Time Locking

Time lock is achieved by reading the NTP time from the NTP Server and calculating an appropriate time-code. NTP locks the SRG-4400 central timing system.

Keep the following mind:

- The time-code needs to be checked and updated each time the NTP Server is detected.
- However in marginal networks the “question-response” message times may be so variable the time-code update should be suppressed until it has been valid for a number of seconds.
- Once the time-code has been set by the NTP Client, the SRG-4400 should not need to re-check the NTP time unless a crash lock has been forced by the phase locking arrangement.

Simplified NTP Flowcharts

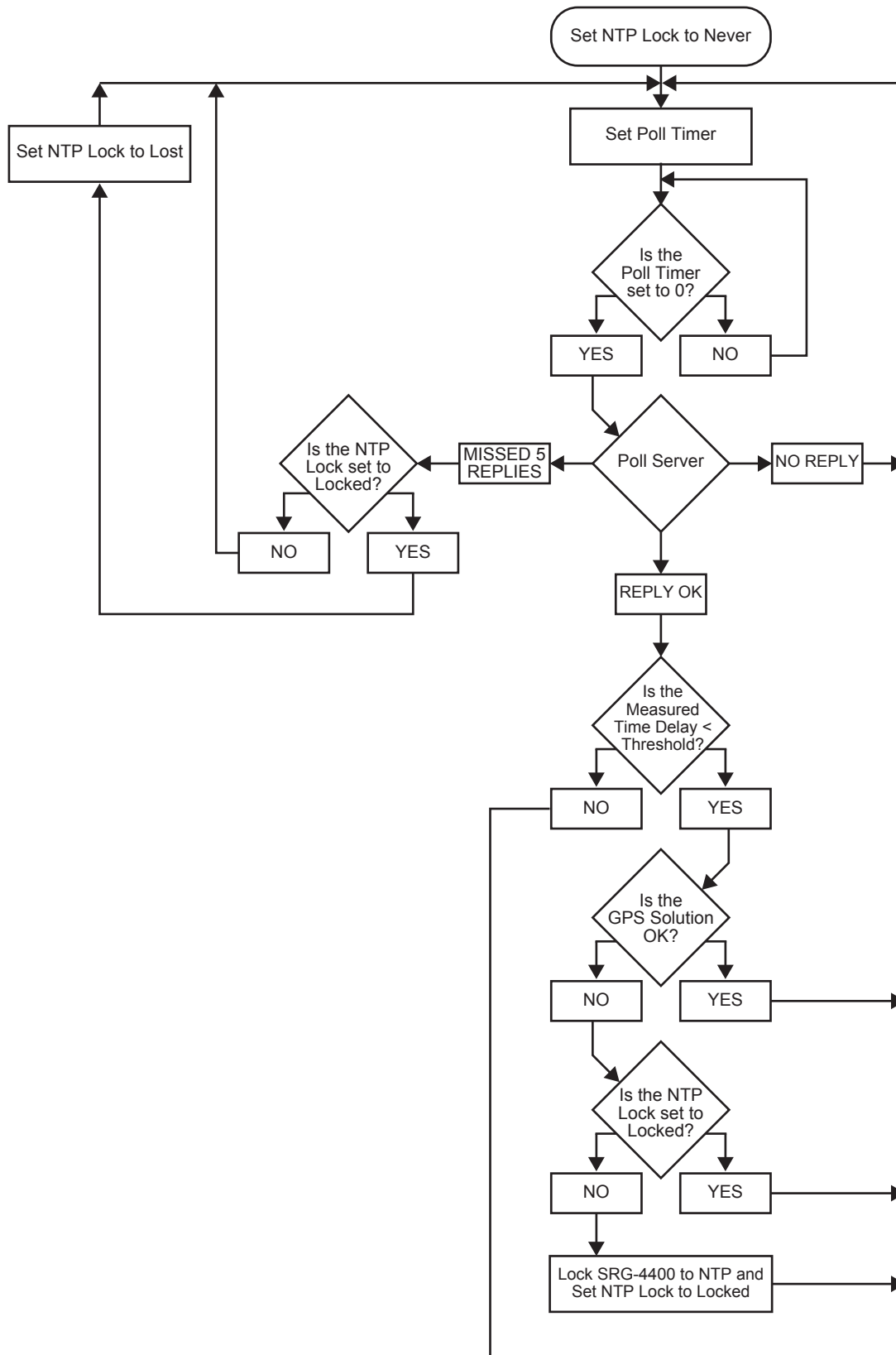

Figure 13.1 NTP Client Flowchart

Required Time Corrections

From an NTP Server, the SRG-4400 Master Clock can derive UTC and also add the appropriate time offset and provide corrected local time. **Table 13.1** contains a list of the various corrections which need to be made by the SRG-4400.

Table 13.1 Required Time Corrections

		Offset	SRG-4400 Update
1	Earth Speed Drift in one day	1ms	Leap second corrections are made approximately every 18 months as determined by International Earth Rotation Service (IERS).
2	Local Time	User defined	The user usually defines the offset from UTC at time of installation
3	Daylight Saving	1 hour	Twice per year

GPS Option

In This Chapter

This chapter provides information on installing the GPS option for your SRG-4400.

The following topics are discussed:

- Before You Begin
- System Requirements
- Installing the GPS Antenna
- Connecting the SRG-4400 to the GPS Antenna
- Operation

Before You Begin

Surge Protection

Surge protection may be required if rooftop antennas are being connected, in order to meet the regulations and standards for lightning protection in the countries where the end-product will be installed.

Lightning protection means actually a protection of people and buildings. If the antenna is hit by a direct lightning strike, your least worry should be damage of the GPS receiver. You should worry about the lightning energy, which can enter the building and directly strike a person or cause fire. A lightning protection shall be mounted at the place where the antenna cable enters the building. The primary lightning protection must be capable of conducting all potentially dangerous electrical energy to PE (Protective Earth). In case of a rooftop antenna, a coax-cable insert is needed. Ross Video doesn't sell these, but there are many companies, which do. The antenna on the roof can't be protected against a direct lightning strike. It will just melt if hit by a direct lightning strike.

Rooftop antenna should be installed by experienced electricians, who are familiar with the local regulations and standards. Not following these regulations may lead to legal actions and rejection of insurance coverage in case of damage from lightning. Make sure to choose a lightning protector with DC-pass and suitable for the GPS frequency range (1.575GHz) with low attenuation.

Notes on Installing an Antenna

Keep the following in mind before installing your antenna and connecting it to your SRG-4400:

- Ensure the Option Key for the GPS feature is enabled on the SRG-4400. Refer to the section “**Option Enable Menu**” on page 5-57 for details.
- The antenna must be positioned away from any buildings or surfaces that could cause reflections to be received by the antenna.
- If you are mounting the antenna on a wall bracket, this assembly must be placed at the top of the wall, so as to gain a clear view of the sky above.
- The GPS antenna cannot be mounted indoors; not even against a window, even one without an anti-glare coating.
- Because the coaxial cable has different connectors at each end, be sure to install it in the correct direction.
- When routing the coaxial cable, be sure to avoid tight corners, where the cable could become kinked. If the low-loss coaxial cable is being installed, this has a much larger diameter and is of a stiffer construction than the standard cable, and will therefore be very difficult to route around tight corners.
- Provide adequate cable strain relief at the SRG-4400.

System Requirements

The SRG-4400 requires an Option Key to enable the GPS sub-system. Additional optional GPS components are available when the GPS Option is ordered as part of your system.

The system works best with a GPS signal level between -125dBm and -117dBm at the SMB plug at the rear of the unit. It can achieve cold start with a -147dBm signal.

Recommended Cables

Table 14.1 summarizes the cable types if you do not purchase one of our GPS options that include the necessary cables.

Table 14.1 Recommended Cables

Cable	Signal Attenuation	Outer Diameter	DC Resistance	Bending Radius	Operating Temperature
RG58 Black PVC or LBC/LMR195	0.66dB/m @ 1.6GHz	5mm	0.05ohms/m	25mm	-40 to +80°C
LBC/LMR400 Black polyethylene	0.18dB/m @ 1.6GHz	10.25mm	0.01ohms/m	50mm	-40 to +80°C

Cable, Antenna, and Amplifier Combinations



Warning — The cable supplied with the GPS-4400-8M and GPS-4400-35M is type LMR195FR or equivalent. In the GPS-4400-100M and GPS-4400-200M include the same cable as found in the GPS-4400-8M plus 100M (or 200M) of LMR400FR. These cables are not a plenum rated. Before installation, verify that the supplied cable(s) meet the local regulatory requirements for your facility.

Table 14.2 summarizes the recommended cabling specifications. Refer also to **Figure 14.5** and **Figure 14.7**.

Table 14.2 Possible Combinations

	Antenna	Cable	Amplifier	Extension Cable	Overall Gain at RF Input	Expected DC Volts at Antenna
GPS-4400-8M	+28dB	8m of RG58	none	none	+22.72dB	4.99
GPS-4400-35M	+28dB	35m of RG58	none	none	+4.9dB	4.97
GPS-4400-100M	+28dB	8m of RG58	none	100m of LBC400	+4.72dB	4.97
GPS-4400-200M	+28dB	8m of RG58	+28dB	200m of LBC400	+14.72dB	4.93

Installing the GPS Antenna

The GPS antenna must be mounted in an outdoor location, and be positioned such that it has an uninterrupted view of the sky, i.e. with as much of the hemisphere of sky above it in plain view.

With the GPS Option enabled, the SRG-4400 provides a 5 volt DC voltage that is impressed upon the RF signal line. The current is internally limited to 50mA. The Ross supplied antenna and line amplifier (optional equipment) require less than 30mA combined.

To install the GPS antenna

1. Remove the nut and washer from beneath the antenna cap.

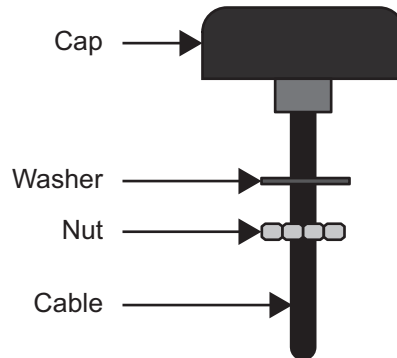

Figure 14.1 Antenna Cap — Location of Nut and Washer

2. Cut a hole in the surface that will allow the cable to be thread through the surface. The cap will rest above the surface. Refer to **Figure 14.2** for dimensions.

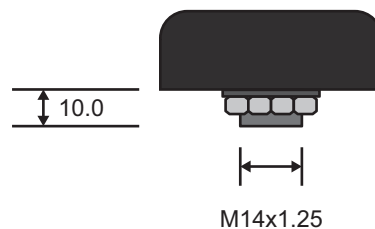

Figure 14.2 Antenna Cap — Dimensions

3. Position the cap above the hole and ensure the cable is easily fed through the hole of the surface.

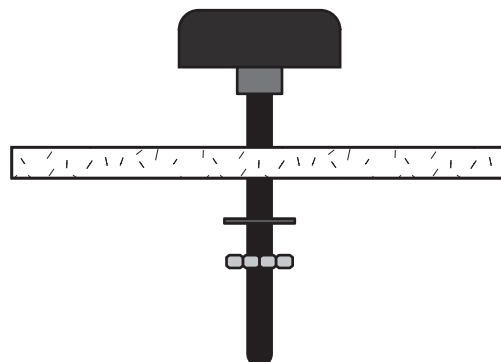

Figure 14.3 Positioning the Antenna Cap

4. Thread the cable through the washer and nut.
5. Use the washer and nut to affix the antenna cap to the surface.

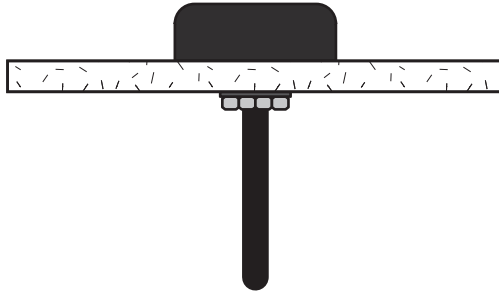

Figure 14.4 *Securing the Antenna Cap*

Connecting the SRG-4400 to the GPS Antenna

There are two methods of connecting the SRG-4400 with a GPS antenna: with an external line amplifier and without an external line amplifier. This section summarizes both methods.

Note that the information presented in this section may differ from the requirements of your facility.

Connection without a Line Amplifier

An external Line Amplifier is not required in setups that do not use a long cable run between the GPS antenna and the SRG-4400.

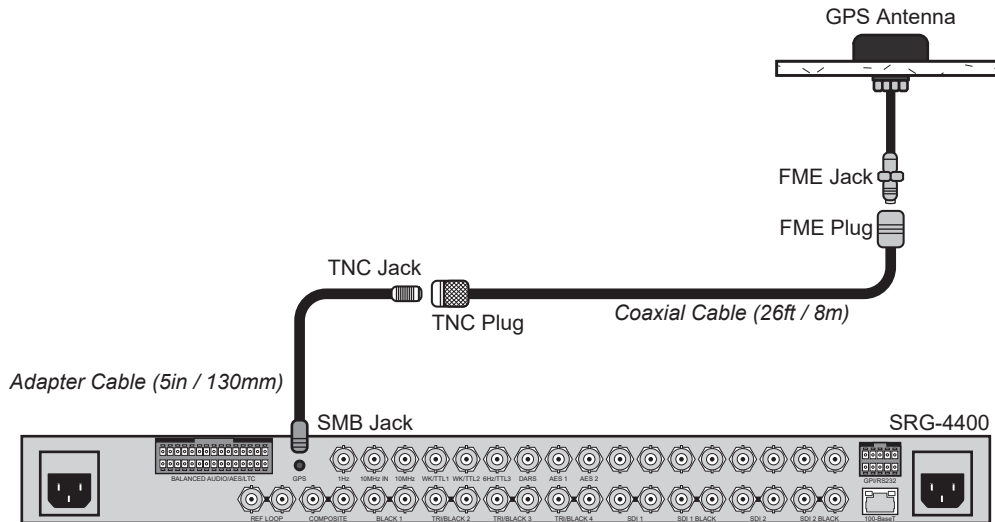

Figure 14.5 GPS-4400-8M, GPS-4400-35M — Connection without an External Line Amplifier

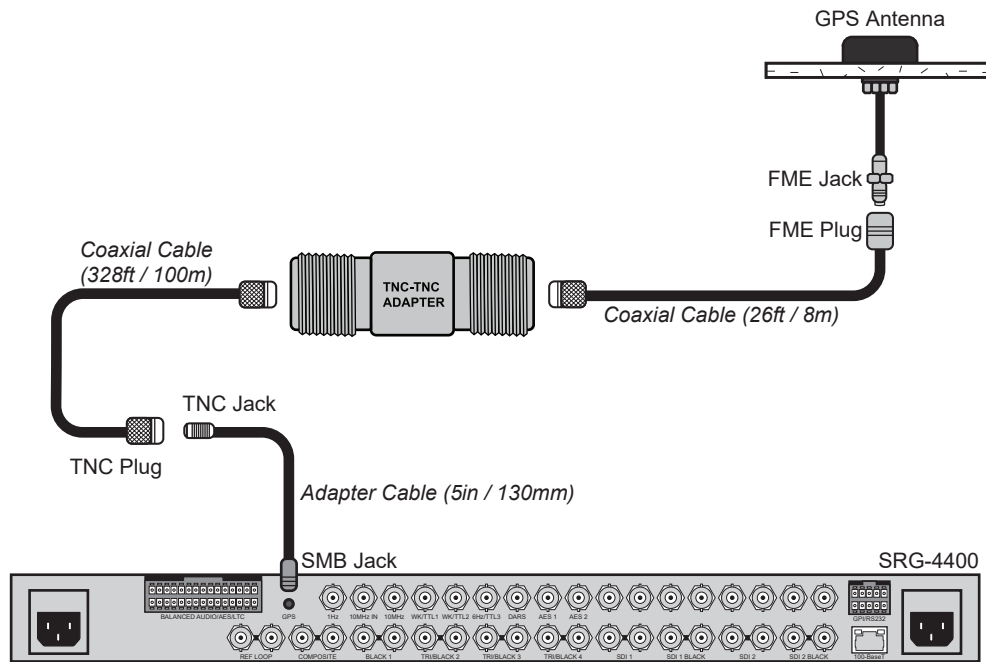

Figure 14.6 GPS-4400-100M — Connection without an External Line Amplifier

Connection with a Line Amplifier

The SRG-4400 can be used with an external Line Amplifier when a long cable run is required. Because of the internal LNA, the overall gain (including signal losses past the external Line Amplifier) should not exceed 35dB. Levels higher than that can affect the jamming detection capability of the SRG-4400.

The external Line Amplifier should have a noise figure better than 1dB. This will give an overall system noise figure of around 2dB. The external Line Amplifier, if having no pre-select filter, needs to be able to handle other signals other than the GPS/GLONASS signal. These signals are typically at much higher levels. The amplifier needs to stay in the linear region when presented with these other signals. Again, the system designer needs to determine all of the unintended signals and their possible levels that can be presented and make sure the external Line Amplifier will not be driven into compression. If this were to happen, the GPS/GLONASS signal itself would start to be attenuated and the GPS/GLONASS performance would suffer.

The external Line Amplifier needs a source of power. It may get this from the 5 volt DC voltage on the antenna cable or an external PSU.

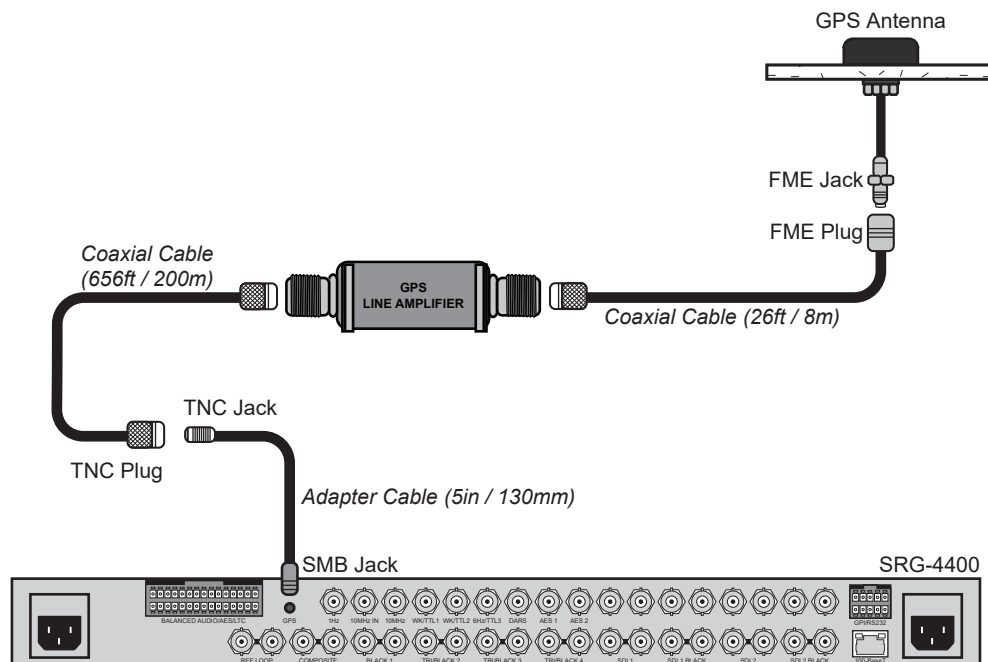

Figure 14.7 GPS-4400-200M — Connection with an External Line Amplifier

Operation

This section provides additional information for operating the SRG-4400 while using an active GPS antenna.

For More Information on...

- GPS signals, refer to *IS-GPS-200E*.
- GLONASS signals, refer to *ICD L1 L2 GLONASS Edition 5.1 2008*.

Locking the SRG-4400 to GPS

One of the best sources of reference for both frequency and time is the Global Positioning System (GPS).

The SRG-4400 uses a 32 channel GPS receiver. As the SRG-4400 is powered, the GPS receiver begins searching for satellites from which it can get time, frequency and phase information. In a good reception area, as many as 12 satellites may be visible. The SRG-4400 requires a minimum of 3 satellites to be located and fully decoded before it can start using the GPS data. The search for the first 3 satellites can take up to 3 minutes, but is often accomplished in 2. If less than 3 satellites are available, the SRG-4400 will not lock to GPS.

Once the minimum of 3 satellites have been located and their GPS data decoded, the SRG-4400 averages the number of counts from all of the detected satellites, and then continually adjusts the free-run oven frequency to generate a condition where the SRG-4400 is locked in frequency and phase to the GPS receiver.

In marginal reception areas, locking/unlocking of the GPS receiver will be tolerated as the short term effect on the free-running oven frequency of the SRG-4400 will be very small. When an unlocked condition is detected, the SRG-4400 software will smoothly revert to the stored free-running oven frequency.

The number of satellites can be monitored on the GPS Report sub-menu available in the System Setup menu. Refer to the section “**System Setup Menus**” on page 5-39 for details.

Time Locking

Time lock is achieved by reading the GPS time from the receiver and calculating an appropriate timecode. GPS locks the SRG-4400 central timing system.

Keep the following in mind:

- The time-code needs to be checked and updated each time the GPS receiver is detected.
- However, in marginal reception, the time-code update should be suppressed until it has been valid for a number of seconds.
- Once the time-code has been set by the GPS receiver, the SRG-4400 should not need to recheck the GPS time unless a crash lock has been forced by the phase locking arrangement.

Frequency Locking

Frequency lock can be established in a few seconds as the oven free-running frequency is within a few ppm of the GPS frequency at all times. The first time the SRG-4400 is powered with a GPS receiver, the SRG-4400 waits for 3 or more satellites to be “fixed”, then the SRG-4400 acquires frequency lock. This first time may take up to 5 minutes from when the GPS lock was acquired.

Frequency lock is achieved when the short-term frequency error is less than 1ppm.

Phase Locking

Phase locking can be established a few minutes after frequency locking. Phase lock is achieved when the long-term frequency error is less than 0.1ppm.

Signal Requirements

The SRG-4400 with GPS Receiver can achieve Cold Start acquisition with a signal level of -147dBm at its input. This means the SRG-4400 can find the necessary satellites, download the necessary ephemeris data and compute the location within a 5 minute period.

The SRG-4400 will display a reported C/No of 40dB-Hz for a signal level of -130dBm into the RF input.

Each GPS and GLONASS satellite presents its own signal to the SRG-4400, and best performance is obtained when the signal levels are between -125dBm and -117dBm. These received signal levels are determined by:

- GPS and GLONASS satellite transmit power
- GPS and GLONASS satellite elevation and azimuth
- Free space path loss
- Extraneous path loss such as rain
- Partial or total path blockage such as foliage or building
- Multi-path caused by signal reflection
- GPS/GLONASS antenna
- Signal path after the GPS/GLONASS antenna

Even though for frequency and phase locking the SRG-4400 does not require a good 3D fix, it still requires three satellites in view to produce a fix.

Required Time Corrections

From a GPS Receiver, the SRG-4400 Master Clock can derive UTC and also add the appropriate time offset and provide corrected local time. **Table 14.3** contains a list of the various corrections which need to be made by the SRG-4400.

Table 14.3 Required Time Corrections

		Offset	SRG-4400 Update
1	Earth Speed Drift in one day	1ms	Leap second corrections are made approximately every 18 months as determined by International Earth Rotation Service (IERS).
2	Local Time	User defined	The user usually defines the offset from UTC at time of installation
3	Daylight Saving	1 hour	Twice per year

System Noise Floor

As mentioned earlier, the SRG-4400 will display a reported C/No of 40dB-Hz for an input signal level of -130dBm. The C/No number means the carrier (or signal) is 40dB greater than the noise floor measured in a 1Hz bandwidth. This is a standard method of measuring GPS receiver performance.

Thermal noise is -174dBm/Hz at room temperature. From this we can compute a system noise figure of 4dB for the SRG-4400. This noise figure consists of the loss of the preselect SAW filter, the noise figure of the LNA as well as implementation losses within the digital signal processing unit.

Simplified GPS Flowchart

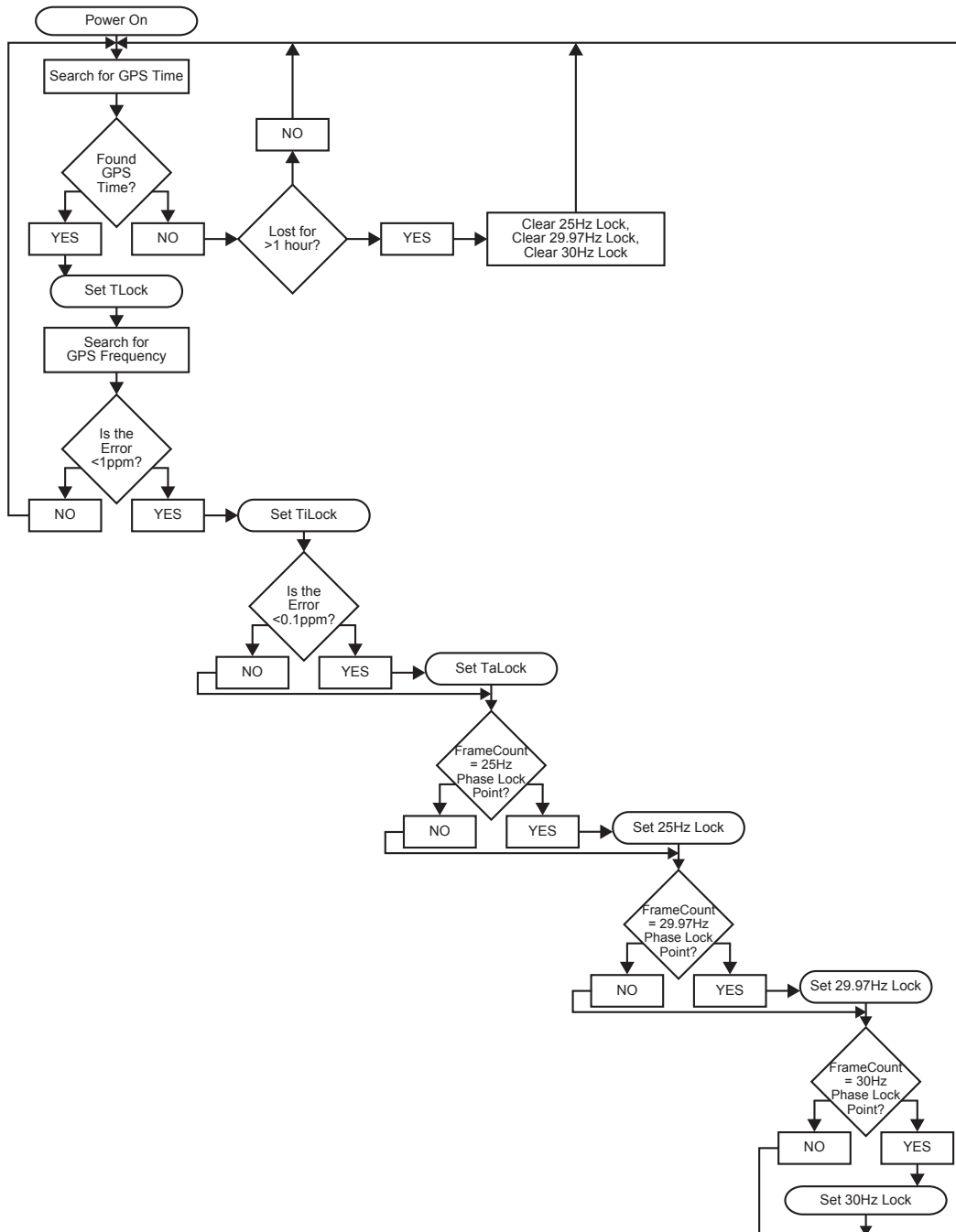

Figure 14.8 Phasing to GPS Flowchart

Troubleshooting RF Interference

This section provides information when troubleshooting radio frequency (RF) interference.

RF Interference into the GPS/GLONASS receiver tends to be the biggest problem when determining why the system performance is not meeting expectations. As mentioned earlier, the GPS and GLONASS signals are at -130dBm and lower. If signals higher than this are presented to the receiver it can be overwhelmed. The SRG-4400 can reject CW in-band jamming signals, but would still be affected by non-CW signals.

The most common source of interference is digital noise. This is created by the fast rise and fall times and high clock speeds of modern digital circuitry. For example, a popular net book computer uses an Atom processor clocked at 1.6GHz. This is only 25MHz away from the GPS signal and virtually at the same frequency as the GLONASS signal. Because of the nature of the address and data lines, this would be broadband digital noise at a relatively high level. Such devices are required to adhere to a regulatory standard for emissions such as ***FCC Part 15 Subpart J Class B*** or ***CISPR 22***.

It is recommended to move the antenna away from the source of interference or shield the digital interference to prevent it from getting to the antenna.

Date in the User Bits of Timecode

In This Chapter

The SRG-4400 supports two methods of date information in the user bits of LTC and VITC:

- *SMPTE 309M-1999* using YYMMDD format, with or without encoded time zone information
- *EBU I29-1995/ITU-R BR.1353 Appendix 2* or commonly known in the industry as ITU/Legacy/BBC format

This chapter provide an overview of how the SRG-4400 inserts and reads the user bits in time code to decode date and time zone information.

SMPTE S309 (YYMMDD Format)	VITC Bit Number	ITU/Legacy/BBC
BG1		
Day units	6	Reserved - set to 0
	7	
	8	
	9	
BG2		
10s of Day units	16	Day units
	17	
	18	
	19	
BG3		
Month units	26	Month units
	27	
	28	
	29	
BG4		
10s of Month units	36	Day 10s of units
	37	Day 10s of units
	38	Month 10s of units
	39	Reserved - set to 0
BG5		
Year Units	46	Reserved - set to 0
	47	
	48	
	49	
BG6		
Year 10s of units	56	Year units
	57	
	58	
	59	
BG7		
Optional Time Zone - 0	66	Reserved - set to 0
Optional Time Zone - 1	67	
Optional Time Zone - 2	68	
Optional Time Zone - 3	69	
BG8		
Optional Time Zone - 4	76	Year 10s of units
Optional Time Zone - 5	77	
Reserved - set to 0	78	
YYMMDD Format = 0	79	

Service Information

In This Chapter

This chapter contains procedures for cleaning and performing preventive maintenance on the SRG-4400, general servicing information, and the warranty policies.

The following topics are discussed:

- User Maintenance
- Warranty and Repair Policy

User Maintenance

This section contains information for cleaning and performing preventive maintenance on the SRG-4400.

General Care

Protect the instrument from adverse conditions, i.e. high humidity, high temperatures, etc. The instrument is NOT waterproof.

When handling the unit or any of its controls, do so with clean hands.

Do not use excessive force to operate any of the controls on the unit.

Exterior Cleaning

Clean the instrument periodically to prevent the accumulation of dust or dirt. Accumulated dust in the instrument acts like an insulating blanket, preventing proper cooling, resulting in overheating and ultimately premature component breakdown. Under high humidity conditions, accumulated dust can also result in an electrically conductive path.



Warning — *To avoid personal injury, always remove the power cord before cleaning the instrument.*

A vacuum cleaner may be used to remove accumulated dust on the outside of the instrument. Ensure that the nozzle is fitted with a soft brush head (or similar) to avoid damaging the instrument.



Caution — *Avoid exposing the instrument to liquids, sprays or solvents, as this could damage the unit. Cleaning agents may also damage the instrument. Avoid solutions that contain harmful chemicals such as Acetone, Benzene, Toluene, Xylene, or similar.*

If the exterior surfaces or controls of the instrument require further cleaning, use a dry, lint-free cloth or a soft-bristle brush. If dirt remains, use a cloth or swab dampened with a 75% isopropyl alcohol solution. A swab is useful for cleaning in narrow spaces around the controls and connectors. Do not use excessive amounts of the approved cleaning solution when cleaning the instrument. Do not use abrasive compounds on any part of the instrument.



Caution — *Do not allow moisture or dust to enter the instrument during exterior cleaning. Only use enough solution to mildly dampen a cloth or similar. After cleaning, use de-ionized water on a clean cloth to “rinse” the instrument.*

Preventive Maintenance

Preventive Maintenance mainly consists of periodic cleaning. Periodic cleaning reduces instrument breakdown and increases reliability. Clean the instrument whenever needed (using the guidelines outlined above), based on the operating environment. Dirty conditions may require more frequent cleaning than a conventional “clean room” environment.

Servicing

The SRG-4400 should require little or no in-service maintenance to the installed electronics. Provided the measures outlined in the section “Preventive Maintenance” on page 2 are adhered to, the product should perform for several years without any major user intervention.

Maintenance of components within the product is not usually required, except under exceptional circumstances. If a fault occurs, please follow the instructions listed in the chapter “Troubleshooting” on page 1 before attempting to service the product. The servicing of any of the internal components requires the unit to be extracted from the bay and the top cover removed. If your problem cannot be resolved, contact Ross Video for further advice.

If you ordered a Service Option, then removing the unit from the bay and returning it to Ross Video for updating will provide the user with the opportunity to inspect the unit for any problems relating to the operating conditions/environment.

Service Safety Overview

Only qualified personnel should perform service procedures. Read this section before performing any service procedures.

- **Do Not Service Alone.** Do not perform internal service or adjustments of this product unless another person capable of rendering first aid and resuscitation is present.
- **Disconnect Power.** To avoid electric shock, switch off the power to the instrument, then disconnect the power cord from the mains power.
- **Use Care When Servicing With Power On.** Dangerous voltages or currents may exist in this product. Disconnect power, remove battery (if applicable), and disconnect test leads before removing protective panels, soldering, or replacing components.
- **Observe Static Precautions.** Servicing of this product should be performed only in a static-safe environment, i.e. at a suitably configured ESD Workstation. Always use a Static Grounding Wrist-Strap connected to the ESD Workstation mat while servicing the product.
- To avoid electric shock, do not touch exposed connections.

Important Information Regarding the use of Switch Cleaners

Switch Cleaner products usually contain a lubricating additive (along with the “alcohol- based” propellant), intended to remain after spraying into relevant components.

Some equipment produced by Ross Video contains components that should not be cleaned using these types of cleaners, due to the compact nature of the components, their operating characteristics, or their inaccessibility. This is because push-buttons, for example, rely on clean, dry, conductive contact surfaces to operate correctly. Applying Switch Cleaner lubricant only serves to attract dust, or worse still could “wash-in” grease and dust, which could severely reduce the conductivity of the component parts.

Therefore, Ross Video does not recommend the use of these Switch Cleaner products on their equipment, and will not be held liable for any fault caused by inadvertent or unqualified use or application of such products.

Warranty and Repair Policy

The SRG-4400 is warranted to be free of any defect with respect to performance, quality, reliability, and workmanship for a period of THREE (3) years from the date of shipment from our factory. In the event that your SRG-4400 proves to be defective in any way during this warranty period, Ross Video Limited reserves the right to repair or replace this piece of equipment with a unit of equal or superior performance characteristics.

Should you find that this SRG-4400 has failed after your warranty period has expired, we will repair your defective product should suitable replacement components be available. You, the owner, will bear any labor and/or part costs incurred in the repair or refurbishment of said equipment beyond the THREE (3) year warranty period.

In no event shall Ross Video Limited be liable for direct, indirect, special, incidental, or consequential damages (including loss of profits) incurred by the use of this product. Implied warranties are expressly limited to the duration of this warranty.

This SRG-4400 User Manual provides all pertinent information for the safe installation and operation of your Ross Video Product. Ross Video policy dictates that all repairs to the SRG-4400 are to be conducted only by an authorized Ross Video Limited factory representative. Therefore, any unauthorized attempt to repair this product, by anyone other than an authorized Ross Video Limited factory representative, will automatically void the warranty. Please contact Ross Video Technical Support for more information.

In Case of Problems

Should any problem arise with your SRG-4400, please contact the Ross Video Technical Support Department. (Contact information is supplied at the end of this publication.)

A Return Material Authorization number (RMA) will be issued to you, as well as specific shipping instructions, should you wish our factory to repair your SRG-4400. If required, a temporary replacement frame will be made available at a nominal charge. Any shipping costs incurred will be the responsibility of you, the customer. All products shipped to you from Ross Video Limited will be shipped collect.

The Ross Video Technical Support Department will continue to provide advice on any product manufactured by Ross Video Limited, beyond the warranty period without charge, for the life of the equipment.

Contact Us

Contact our friendly and professional support representatives for the following:

- Name and address of your local dealer
- Product information and pricing
- Technical support
- Upcoming trade show information

Technical Support

Telephone: +1 613 • 652 • 4886
After Hours Emergency: +1 613 • 349 • 0006
Email: techsupport@rossvideo.com

General Information

Telephone: +1 613 • 652 • 4886
Fax: +1 613 • 652 • 4425
Email: solutions@rossvideo.com
Website: <http://www.rossvideo.com>

Visit Us

Visit our website for:

- Company information and news
- Related products and full product lines
- Online catalog
- Testimonials