ACO-2200 User Guide

Thank You for Choosing Ross

You've made a great choice. We expect you will be very happy with your purchase of Ross Technology.

Our mission is to:

1. Provide a Superior Customer Experience
 - offer the best product quality and support
2. Make Cool Practical Technology
 - develop great products that customers love

Ross has become well known for the Ross Video Code of Ethics. It guides our interactions and empowers our employees. I hope you enjoy reading it below.

If anything at all with your Ross experience does not live up to your expectations be sure to reach out to us at solutions@rossvideo.com.



David Ross
CEO, Ross Video
dross@rossvideo.com

Ross Video Code of Ethics

Any company is the sum total of the people that make things happen. At Ross, our employees are a special group. Our employees truly care about doing a great job and delivering a high quality customer experience every day. This code of ethics hangs on the wall of all Ross Video locations to guide our behavior:

1. We will always act in our customers' best interest.
2. We will do our best to understand our customers' requirements.
3. We will not ship crap.
4. We will be great to work with.
5. We will do something extra for our customers, as an apology, when something big goes wrong and it's our fault.
6. We will keep our promises.
7. We will treat the competition with respect.
8. We will cooperate with and help other friendly companies.
9. We will go above and beyond in times of crisis. *If there's no one to authorize the required action in times of company or customer crisis - do what you know in your heart is right. (You may rent helicopters if necessary.)*

ACO-2200 · User Guide

- Ross Part Number: 2200DR-004-05
- Release Date: April 6, 2020.

Copyright

© 2020 Ross Video Limited. Ross®, openGear®, and any related marks are trademarks or registered trademarks of Ross Video Ltd. All other trademarks are the property of their respective companies. PATENTS ISSUED and PENDING. All rights reserved. No part of this publication may be reproduced, stored in a retrieval system, or transmitted in any form or by any means, mechanical, photocopying, recording or otherwise, without the prior written permission of Ross Video. While every precaution has been taken in the preparation of this document, Ross Video assumes no responsibility for errors or omissions. Neither is any liability assumed for damages resulting from the use of the information contained herein.

Patents

Patent numbers US 7,034,886; US 7,508,455; US 7,602,446; US 7,802,802 B2; US 7,834,886; US 7,914,332; US 8,307,284; US 8,407,374 B2; US 8,499,019 B2; US 8,519,949 B2; US 8,743,292 B2; GB 2,419,119 B; GB 2,447,380 B; and other patents pending.

Safety Notices

Refer to the “**Important Regulatory and Safety Notices**” document that accompanied your product.

EMC Notices

United States of America FCC Part 15

This equipment has been tested and found to comply with the limits for a class A Digital device, pursuant to part 15 of the FCC Rules. These limits are designed to provide reasonable protection against harmful interference when the equipment is operated in a commercial environment. This equipment generates, uses, and can radiate radio frequency energy and, if not installed and used in accordance with the instruction manual, may cause harmful interference to radio communications. Operation of this equipment in a residential area is likely to cause harmful interference in which case the user will be required to correct the interference at their own expense.

Notice — *Changes or modifications to this equipment not expressly approved by Ross Video Limited could void the user's authority to operate this equipment.*

Canada

This Class “A” digital apparatus complies with Canadian ICES-003.

Cet appareil numérique de la classe “A” est conforme à la norme NMB-003 du Canada.

Europe

This equipment is in compliance with the essential requirements and other relevant provisions of CE Directive 93/68/EEC.

International

This equipment has been tested to CISPR 22:2009 and found to comply with the limits for a Class A Digital device.

Notice — *This is a Class A product. In domestic environments, this product may cause radio interference, in which case the user may have to take adequate measures.*

Maintenance/User Serviceable Parts

Routine maintenance to this Ross Video product is not required. This product contains no user serviceable parts. If the module does not appear to be working properly, please contact Technical Support using the numbers listed under the “Contact Us” section on the last page of this manual. This product is covered by a generous 1-year warranty. See the “Warranty and Repair Policy” section in this manual for details.

Environmental Information

The equipment that you purchased required the extraction and use of natural resources for its production. It may contain hazardous substances that could impact health and the environment.

To avoid the potential release of those substances into the environment and to diminish the need for the extraction of natural resources, Ross Video encourages you to use the appropriate take-back systems. These systems will reuse or recycle most of the materials from your end-of-life equipment in an environmentally friendly and health conscious manner.

The crossed out wheelee bin symbol invites you to use these systems.



If you need more information on the collection, re-use, and recycling systems, please contact your local or regional waste administration. You can also contact Ross Video for more information on the environmental performance of our products.

Company Address



Ross Video Limited

8 John Street
Iroquois, Ontario, K0E 1K0
Canada

Ross Video Incorporated

P.O. Box 880
Ogdensburg, New York
USA 13669-0880

General Business Office: (+1) 613 • 652 • 4886

Fax: (+1) 613 • 652 • 4425

Technical Support: (+1) 613 • 652 • 4886

After Hours Emergency: (+1) 613 • 349 • 0006

E-mail (Technical Support): techsupport@rossvideo.com

E-mail (General Information): solutions@rossvideo.com

Website: <http://www.rossvideo.com>

Contents

Introduction	7
Related Publications	7
Documentation Conventions	7
Interface Elements	7
User Entered Text	7
Referenced Guides	7
Menu Sequences	7
Important Instructions	8
Contacting Technical Support	8
Before You Begin	9
Features	9
Functional Block Diagram	10
Hardware Overview	11
Front Panel Overview	11
Rear Panel Overview	11
Physical Installation	13
Before You Begin	13
Static Discharge	13
Unpacking	13
Initial Product Inspection	13
Operating Environment Requirements	13
Rack Mount Installation	14
Installing the ACO-2200 into a Rack Unit	14
Installing the Rear Support Brackets	14
Connecting Power	15
Setting the Initial IP Address	15
Configuring the DIP Switches	15
Accessories and Options	16
User Documentation	16
DC Power Supply Bricks	16
Power Cords	16
Functional Check Procedures	17
Required Equipment	17
Functional Check Procedure and First Time Operation	17
Initial Power-Up	17
Recommendation	18
Using DashBoard	19
Initial Configuration	20
Performing Functional Checks	21
Normal Operation (No Faults)	22
Loss of the Primary Signal	22
Loss of Power	23
Operational Configuration	23
Power	23
Signals	23

Operating Basics	25
Overview	25
Operating Modes	25
Fault Reporting	25
Software Field Upgrades	25
Uploading the Software Files	25
DashBoard Menus	27
Slot 0 - ACO-2200 Tabs	27
System Report Tab	27
Events Tab	27
Temperature Tab	28
Status Tab	28
PSU Status Tab	28
Slot 1 - Channel Setup Tabs	29
Status Tab	29
Configuration Tab	29
Channels 1-6 Tab	30
Slot 16 - System Setup Tabs	30
Network Tabs	31
Calibration 01 - 06 Tab	32
Technical Specifications	33
General Characteristics	33
Performance Conditions	33
BNC Channels	33
Ethernet Interface	34
DC Power Source	34
Physical Specifications	34
Clearance	34
Mechanical Characteristics	34
Environment Characteristics	34
Service Information	37
User Maintenance	37
General Care	37
Exterior Cleaning	37
Preventive Maintenance	38
Servicing	38
Service Safety Overview	38
Important Information Regarding the use of Switch Cleaners	38
Troubleshooting Checklist	39
Contacting Ross Video Technical Support	39
Warranty and Repair Policy	39
Glossary	41

Introduction

This guide covers the installation, configuration, and use of the ACO-2200 Automatic Changeover System. The following chapters are included:

- “**Introduction**” summarizes the guide and provides important terms, and conventions.
- “**Before You Begin**” provides a brief product overview and installation requirements for the ACO-2200.
- “**Hardware Overview**” outlines the front and rear panel features of the ACO-2200.
- “**Physical Installation**” provides instructions for the basic physical installation of the ACO-2200.
- “**Functional Check Procedures**” guides you through the steps required to check the operation of the ACO-2200.
- “**Operating Basics**” outlines the operating modes, monitoring features, and the steps necessary to upgrade the software programmed on the main module.
- “**DashBoard Menus**” summarizes the DashBoard menu system available.
- “**Technical Specifications**” provides the specifications for the ACO-2200.
- “**Service Information**” provides information on the warranty and repair policy for your ACO-2200.
- “**Glossary**” provides a list of terms used throughout this guide.

Related Publications

It is recommended to consult the following Ross documentation before installing and configuring your ACO-2200:

- *ACO-2200 Quick Start Guide*, Ross Part Number: 2200DR-002
- *SRG-2200 User Guide*, Ross Part Number: 2200DR-104
- *SRG-2200 Quick Start Guide*, Ross Part Number: 2200DR-102

Documentation Conventions

Special text formats are used in this guide to identify parts of the user interface, text that a user must enter, or a sequence of menus and sub-menus that must be followed to reach a particular command.

Interface Elements

Bold text is used to identify a user interface element such as a dialog box, menu item, or button. For example:

In the **Edit** dialog, click **Insert Above**.

User Entered Text

Courier text is used to identify text that a user must enter. For example:

In the **Language** box, enter **English**.

Referenced Guides

Italic text is used to identify the titles of referenced guides, manuals, or documents. For example:

For more information, refer to the *DashBoard User Manual*.

Menu Sequences

Menu arrows are used in procedures to identify a sequence of menu items that you must follow. For example, if a step reads “**File > Save As**,” you would select the **File** menu and then select **Save As**.

The term **[Confirm]** indicates that you should press the Rotary Control, and **[Back]** indicates that you should press the blue push-button.

Important Instructions

Star icons are used to identify important instructions or features. For example:

- ★ Contact your IT department before connecting to your facility network to ensure that there are no conflicts. They will provide you with an appropriate value for the IP Address, Subnet Mask, and Gateway for your ACO-2200.

Contacting Technical Support

At Ross Video, we take pride in the quality of our products, but if problems occur, help is as close as the nearest telephone.

Our 24-hour Hot Line service ensures you have access to technical expertise around the clock. After-sales service and technical support is provided directly by Ross Video personnel. During business hours (Eastern Time), technical support personnel are available by telephone. After hours and on weekends, a direct emergency technical support phone line is available. If the technical support person who is on call does not answer this line immediately, a voice message can be left and the call will be returned shortly. This team of highly trained staff is available to react to any problem and to do whatever is necessary to ensure customer satisfaction.

- **Technical Support:** (+1) 613-652-4886
- **After Hours Emergency:** (+1) 613-349-0006
- **E-mail:** techsupport@rossvideo.com
- **Website:** <http://www.rossvideo.com>

Before You Begin

The ACO-2200 is designed for high reliability Master Sync operations where two SRG-2200 units are provided as a fail-safe Primary and Backup pair. The ACO-2200 provides automatic fail over to the wide range of SRG-2200 reference signals.

The ACO-2200 provides user-selection of reference sources. Automatic changeover may occur upon fault detection in any active source.

The ACO-2200 is an in-line device without internal buffers. Switching for all channels is by mechanical relay. The ACO-2200 also provides internal termination for unswitched BNC inputs.

The ACO-2200 includes 6 channels in a 1U rack. Each BNC channel consists of a Primary Input, a Backup Input, and an Output. All BNC channel relays switch in unison upon fault detection in any active BNC channel, front-panel command, or remote command.

The ACO-2200 uses signal amplitude as the basis for error checking. You can configure each BNC channel to check for a different type of input. There is a selection of predefined checking levels relating to the various signals that are supported:

- No Measurement
- Color Black (no ancillary signals present, i.e. only Sync and Burst)
- Color Black + VITC (with one or some ancillary signals present)
- 600mV Tri Sync
- SD SDI - LOS
- HD SDI - LOS
- 3G SDI - LOS
- 1V 10MHz
- 1V Sub-carrier
- 1V AES
- 2V Pulses - LOS
- 4V Pulses - LOS

For the common signals, a fault is reported when the input signal level falls below a predetermined ratio of the nominal peak value. Visual fault indications appear on the front-panel display for signals from both the Primary and Backup SRG-2200s. These indications remain on until cleared by the operator.

The signal reference amplitudes used for fault detection are programmed during factory calibration. The ACO-2200 includes dual external +12V PSUs, which provides power supply failure redundancy.

Features

The ACO-2200 includes the following key features:

- 6 channels in 1U rack height
- All BNC channels are signal agnostic
- All BNC channels are measured on both Primary and Backup inputs
- Ethernet (100-BaseT) interface remote control
- No fans
- All Configuration settings performed through Dashboard
- Tight integration with SRG-2200

Functional Block Diagram

This section provides the functional block diagram that outlines the workflow of the ACO-2200.

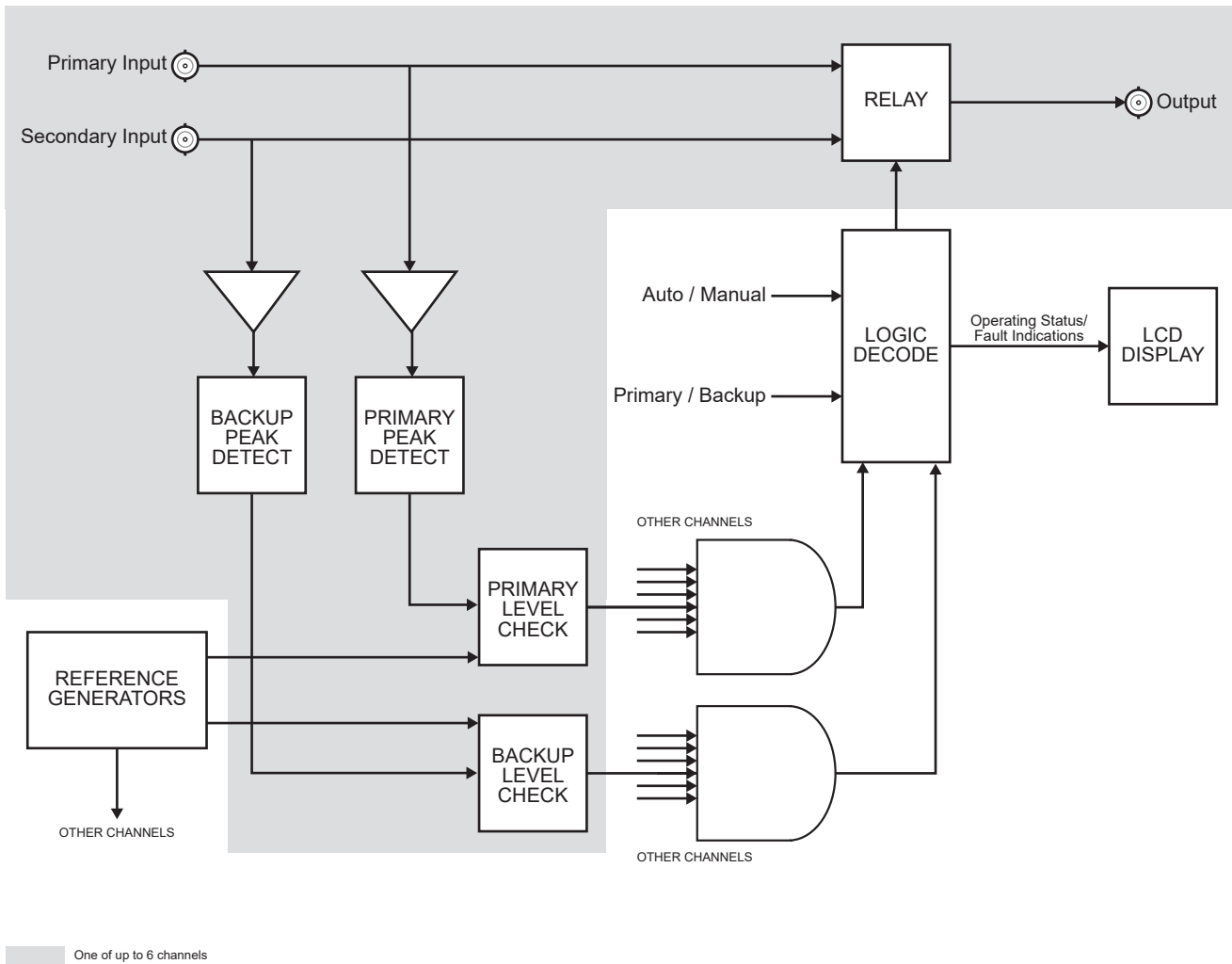

Figure 2.1 ACO-2200 — Functional Diagram

Hardware Overview

This chapter outlines the basics of operating the ACO-2200.

Front Panel Overview

Figure 3.1 shows the ACO-2200 Front Panel. Descriptions of the Front Panel controls and indicators appear below.

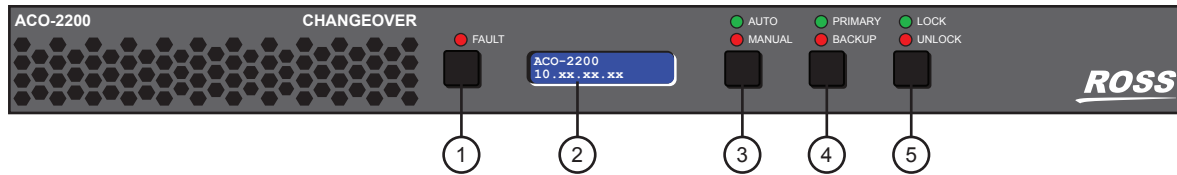

Figure 3.1 ACO-2200 — Front Panel

- | | | |
|-------------------------|--|--------------------------------------|
| 1) FAULT Button and LED | 3) Automatic/Manual Mode Button and LEDs | 5) Panel Lock/Unlock Button and LEDs |
| 2) LED Display | 4) Primary/Backup Mode Button and LEDs | |

1. FAULT Button and LED

The red LED illuminates to indicate a fault condition. Pressing the **FAULT** button cycles the display between fault status messages and the ACO-2200 IP Address.

2. LED Display

The LED Display cycles through a series of Status messages including the IP Address of the unit, and fault status messages.

3. Automatic/Manual Mode Button and LEDs

This button enables the user to select Automatic or Manual mode.

4. Primary/Backup Mode Button and LEDs

This button enables the user to select either the Primary or Backup inputs.

5. Panel Lock/Unlock Button and LEDs

This button allows the user to select if the front panel buttons are locked or unlocked.

Rear Panel Overview

Figure 3.2 shows the ACO-2200 Rear Panel. Descriptions of the rear-panel connectors appear on the following pages.

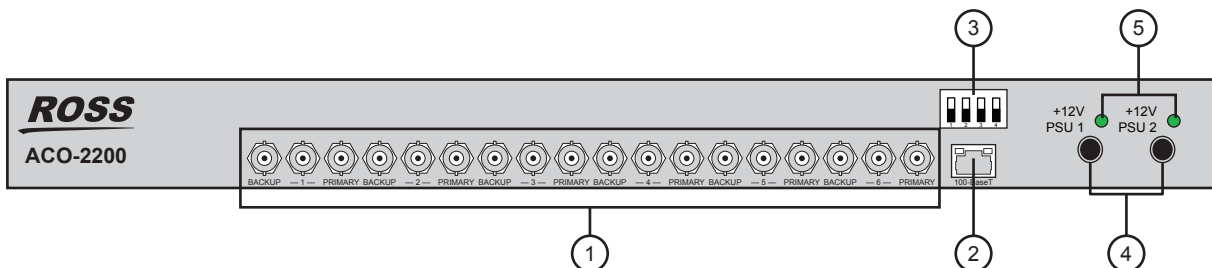

Figure 3.2 ACO-2200 — Rear Panel

- | | | |
|-----------------------------------|-------------------|----------------------|
| 1) BACKUP - # - PRIMARY BNCs | 3) DIP Switches | 5) PSU Presence LEDs |
| 2) Ethernet 100-Base T Connection | 4) PSU Connectors | |

1. BACKUP - # - PRIMARY BNCs

Each triplet of BNCs relates to one changeover channel, comprising of a Primary input, a Backup input, and an output.

- › **BACKUP** — An input from the Backup SRG-2200 is connected here. The signal applied must be the same format as the Primary.
- › **#** — The switched output from either the Primary input or the Backup input appears on the center BNC of each triplet. Which input appears here, and when, is determined by the configuration of the unit.
- › **PRIMARY** — An input from the Primary SRG-2200 is connected here. The signal can be any one of the supported types. The signal applied must be the same format as the Backup. If the channel is configured for “No Measurement”, almost any signal may be connected (the user must take into account, and be aware of, the limitations of the switching relay regarding voltage, current and signal bandwidth).

2. Ethernet 100-Base T Connection

This rear-panel connector is a standard RJ45 Ethernet connector. This is used for DashBoard communication. After installation, it may be used to upload software updates.

3. DIP Switches

Use the DIP switches to force the IP Address and Subnet Mask for the ACO-2200 to known values.

4. PSU Connectors

The ACO-2200 is designed to operate from an external +12VDC power source. A safety earth stud is provided for earth bonding the chassis if you so require.

You need to provide two power connections (for the two external +12V DC Power Bricks). For full power security, these should be separate, independent and secure power grids. However, you still gain the security of power supply failure redundancy if you use the same power grid for both connections.

5. PSU Presence LEDs

These LEDs indicate presence or absence of +12V.

Physical Installation

This chapter provides instructions for installing the ACO-2200.

Before You Begin

Before installing the ACO-2200, refer to the document “**Important Regulatory and Safety Notices to Service Personnel**” that shipped with your unit for general safety information.

Static Discharge

Throughout this manual, please heed the following cautionary note:



ESD Susceptibility — *Static discharge can cause serious damage to sensitive semiconductor devices. Avoid handling circuit boards in high static environments such as carpeted areas and when synthetic fiber clothing is worn. Always exercise proper grounding precautions when working on circuit boards and related equipment.*

Unpacking

Unpack each ACO-2200 you received from the shipping container and ensure that all items are included. If any items are missing or damaged, contact your sales representative or Ross Video directly.

Initial Product Inspection

Perform the following Initial Product Inspection Procedure when you receive your ACO-2200:

1. Inspect the shipping carton for external damage, which may indicate possible damage to the ACO-2200. If damage exists, document it, including photographs, to support any insurance claim.
 2. Remove the instrument from the shipping carton.
 3. Check that the ACO-2200 has not been damaged in transit. The exterior should not have any scratches or impact marks. Prior to shipment the ACO-2200 is thoroughly inspected for mechanical defects.
 4. Verify that the shipping carton contains the instrument, the standard accessories, and any optional accessories that you ordered.
 5. Perform the Functional Check Procedure as outlined in the section “**Required Equipment**” on page 17 after installing the ACO-2200.
- ★ Save the shipping carton and packaging materials for ACO-2200 replacement re-packaging in case return shipment becomes necessary.

Operating Environment Requirements

Verify that the location of your installation has the proper operating environment. The ACO-2200 operates correctly in ambient temperatures from 0 °C to +40 °C and relative humidity from 20% to 80%.

For More Information on...

- environmental operating specifications, refer to the appendix “**Technical Specifications**” on page 33.

The ACO-2200 requires 2” (50mm) of side clearance for counter top use. Also, ensure sufficient rear clearance, e.g. 3” (75mm), so that cables are not compromised.

The ACO-2200 does not have an internal fan to assist with ventilation or cooling. Therefore, when you install the unit in an equipment bay, it is imperative that you ensure there is sufficient space all around the unit to allow the airflow to vent away any excess heat generated by the unit.



Caution — *The ACO-2200 could be damaged if it is powered on at temperatures or humidities outside the specified ranges.*

Rack Mount Installation

You can install the ACO-2200 into an equipment rack. It is recommended to loom the cables so that they do not introduce extra weight or twisting force on the front panel rack mountings or rear panel connectors. If installed in a mobile application, the rack mount kit is essential.

This section describes how to install the ACO-2200 into the rack.

Installing the ACO-2200 into a Rack Unit

The ACO-2200 mounts in the rack cabinet by means of four screws through the front mounting flanges. This should normally be sufficient to carry the load, including weight of cables. Refer to the *ACO-2200 Quick Start Guide* for mounting details.

Installing the Rear Support Brackets



Warning — *Do not use the support brackets to carry the ACO-2200. The brackets are not primarily designed for this purpose, and property damage or personal injury may result.*

In some cases, (mobile trucks, etc.) it may be desirable to also support the rear of the ACO-2200. The rear support bars can be attached to the ACO-2200 in six possible positions. (**Figure 4.1**)

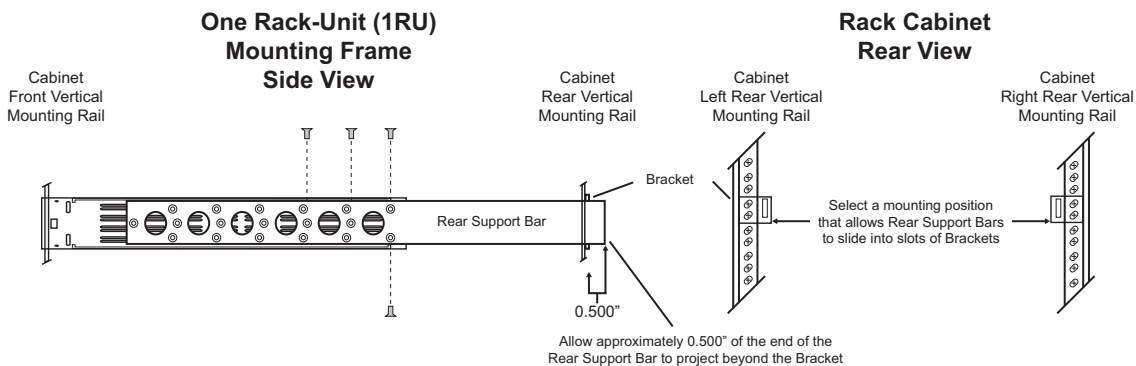

Figure 4.1 Installing the Support Brackets

To install the support brackets

1. Choose the position that suits the cabinet depth and will give approximately a 0.5” projection beyond the previously mounted bracket. The frame support bars can work with racks up to 26” deep.
2. Using four screws per bracket, as shown in **Figure 4.1**, attach both bars.
3. Mount the frame to the front rails of the rack cabinet using rack screws.
4. At the rear of the cabinet, slide the bracket slots over the rear of the support bars and secure to the cabinet rear rails with rack screws.

Connecting Power

The ACO-2200 operates from an externally supplied +12VDC power source. A safety earth stud is provided for earth bonding the chassis if you so require.

Your ACO-2200 includes two external +12VDC power supply blocks to provide you with full redundancy. For full power security, these should be on separate, independent and secure power grids. However, you still gain the security of power supply failure redundancy if you use the same power grid for both connections.

Connecting the Power Cable

Connect the power cable to the instrument first, and then connect it to the AC power source. Note that connecting a live power cable causes the instrument to power on.



Caution — *The ACO-2200 does not have a power switch.*

Replacing a Power Supply

Since DC power is provided from an external supply, if you need to replace a power supply, simply replace the faulty external PSU.

Setting the Initial IP Address

The ACO-2200 is remotely controlled over an Ethernet link by a DashBoard client.

When using DashBoard to communicate with the ACO-2200, the ACO-2200 is always configured as a fixed IPv4 device using the DashBoard in conjunction with DIP switches **SW1** and **SW2** on the rear panel.

Configuring the DIP Switches

This section briefly summarizes the DIP Switch settings on the ACO-2200.

Figure 4.2 shows the DIP Switches in the **OFF** position.



Figure 4.2 DIP Switches on ACO-2200 Rear Panel

SW1 and **SW2** are used in conjunction with the DashBoard menus to set the IP Address of the ACO-2200. Refer to **Table 4.1** and the rear panel labeling for DIP Switch positions.

Table 4.1 SW1 and SW2 Positions

SW1 Position	SW2 Position	Descriptions
OFF	OFF	The ACO-2200 network settings can be set by the user from DashBoard (default).
OFF	ON	No functionality.
ON	OFF	The ACO-2200 IP Address is set to 192.168.2.1 The ACO-2200 Subnet Mask is set to 255.255.255.0.
ON	ON	The ACO-2200 IP Address is set to 10.1.2.1. The ACO-2200 Subnet Mask is set to 255.255.255.0.

Accessories and Options

The following accessories are shipped with the ACO-2200.

User Documentation

A Documentation Resources disk is included with your ACO-2200.

DC Power Supply Bricks

Two +12V DC, 4A power supply bricks with suitable connectors are supplied with the ACO-2200.

Power Cords

All ACO-2200 are shipped with one of the following power cord options:

- Power cords for use in the United Kingdom are BS1363 approved.
- Power cords for use in North America are UL listed and CSA certified.
- Power cords for use in Europe conform to CEE7, DIN49441 and VDE standards.
- Cords for use in other areas are approved by at least one authority acceptable in the country to which the product is shipped.

Functional Check Procedures

Perform the following procedures if you are operating the ACO-2200 for the first time (to verify that the ACO-2200 shipped without damage), or you suspect that the ACO-2200 is not working properly.

Required Equipment

The following equipment is required for the functional check:

- TV signal generator
- Multi-format waveform/picture monitors
- 75ohm BNC cables

Functional Check Procedure and First Time Operation

These procedures will guide you through the steps required to check the operation of the ACO-2200. The most common scenarios will be explored to enable the user to familiarize themselves with the operation of the unit. Although some steps are included which suggest cycling through menu options in order to check operation, this is not mandatory - a simple check for presence or absence of a signal will suffice. Full details regarding the options available in each of the menus are described in the chapter “**DashBoard Menus**” on page 27 of this manual. The scenarios to be explored are:

1. Initial Power-Up
2. Initial Configuration
3. Normal Operation (no fault)
4. Loss and Restoration of a Primary Signal
5. Loss and Restoration of a Backup Signal
6. Loss and Restoration of Power

Only one channel will be considered here to avoid confusion. To check the whole unit, repeat this procedure for each of the remaining channels, remembering to leave signals connected to previously checked channels.

Initial Power-Up

1. Ensure that the ACO-2200 is not powered on.
2. Connect the ACO-2200 as shown in **Figure 5.1**. Ensure that the ACO-2200 output is properly terminated at the monitoring device.

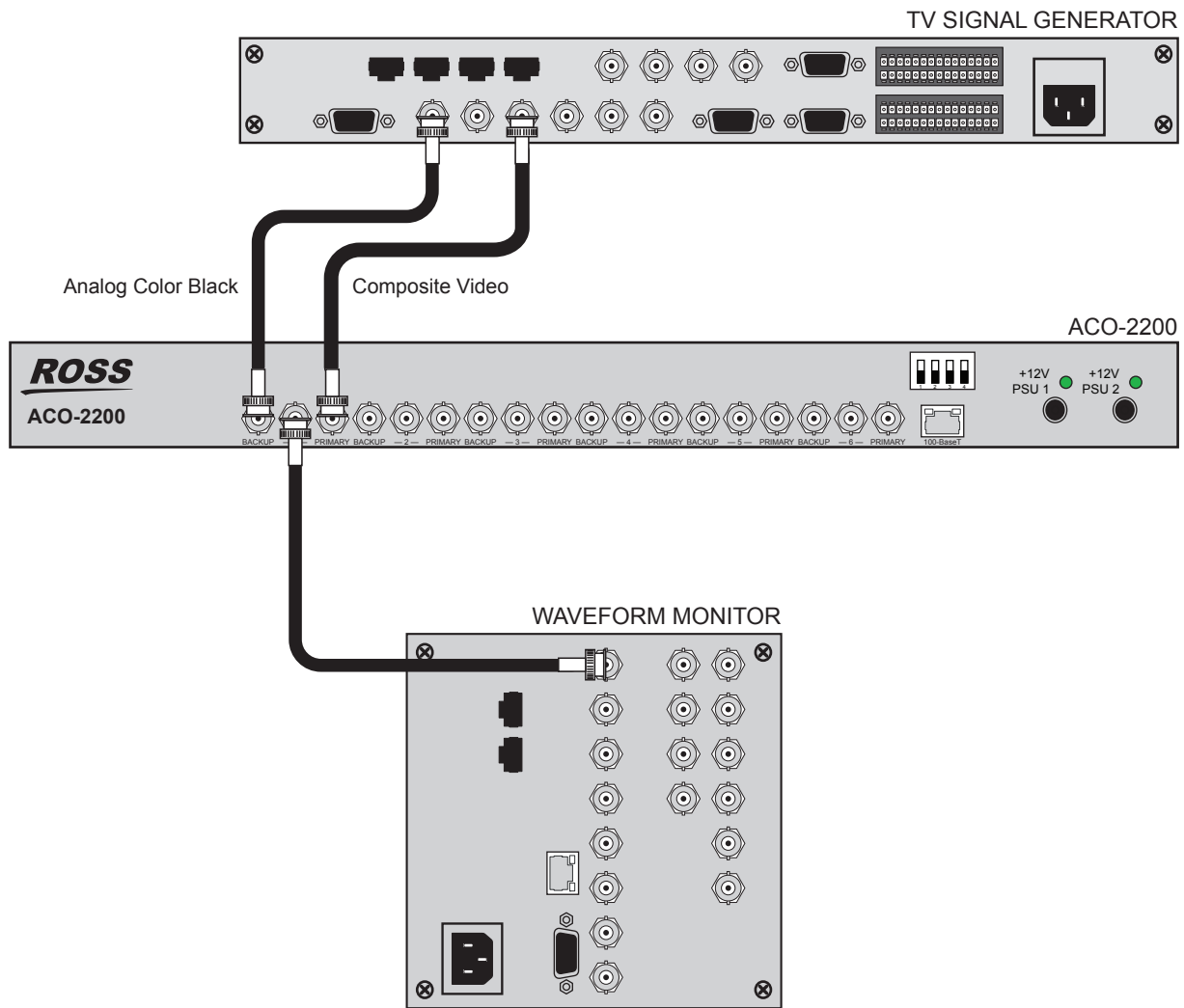

Figure 5.1 Functional Check Connections

- ★ The signal inputs are nominally different in order to easily verify which signal is switched to the output.
- 3. Apply power to the ACO-2200 by connecting it to the power source(s). The instrument runs its power-on initialization process.
- 4. Check that no error messages appear on the LCD display.
- 5. Much of the functional check can be carried out immediately. However, some calibration settings are only guaranteed once functional temperature has stabilized (which should occur after 20 minutes). It is good practice to soak the instrument before proceeding.
- 6. User settings are made using Dashboard.

Recommendation

The ACO-2200 menu system contains an appreciable number of pre-programmed and user selectable settings. All of these settings are programmed using the factory default procedure, and a select few are then adjusted during testing and alignment. This is especially true of the Calibration menu, where settings relating to the fundamental operation of each individual ACO-2200 are stored. If memory corruption occurs, some or all of the settings may need to be re-instated.

For More Information on...

- the entire menu system refer to the chapter “**DashBoard Menus**” on page 27.

Using DashBoard

Before proceeding, ensure that the DashBoard Control System™ is installed on a PC connected to your facility network. The DashBoard software and user manual area available from the Ross Video website.

For More Information on...

- installing DashBoard, refer to the *DashBoard User Manual*.

To launch DashBoard

1. Ensure that you are running DashBoard software version 8.0.0 or higher.
2. Launch DashBoard by double-clicking its icon on your desktop.

To manually add the ACO-2200 to the Basic Tree View in DashBoard

1. From the DashBoard main toolbar, select **File > New > TCP/IP DashBoard Connect or openGear Device**.

The **New TCP openGear Frame Connection** dialog opens.

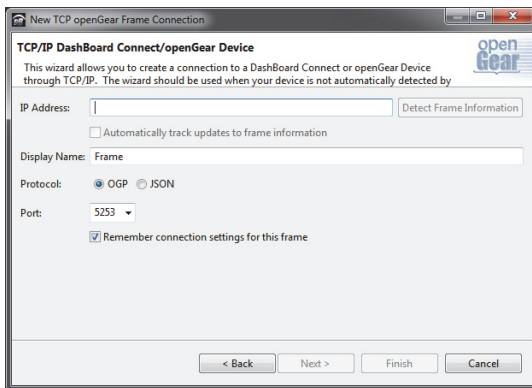

2. Type the IP address of the ACO-2200 in the **IP Address** field.
3. Type a unique name for the ACO-2200 in the **Display Name** field. This name makes the ACO-2200 easily identifiable in the Tree View.
4. Click **Finish**.
5. Ensure that the ACO-2200 is displayed in the Tree View located on the left-side of the DashBoard window. Consult the *DashBoard User Manual* should the Tree View not display the ACO-2200.

To access the ACO-2200 interfaces in DashBoard

1. From the **Tree View**, expand the node for the ACO-2200 you wish to configure.

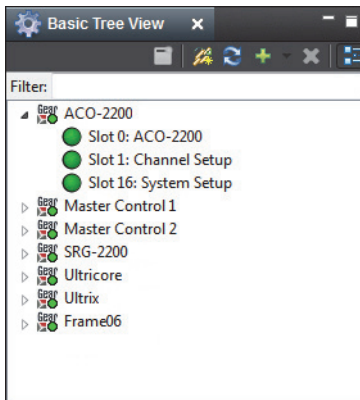

2. Double-click a node to display its interface in the right-side of the DashBoard window. In the example below, the **Slot 0: ACO-2200** interface is displayed in the window.

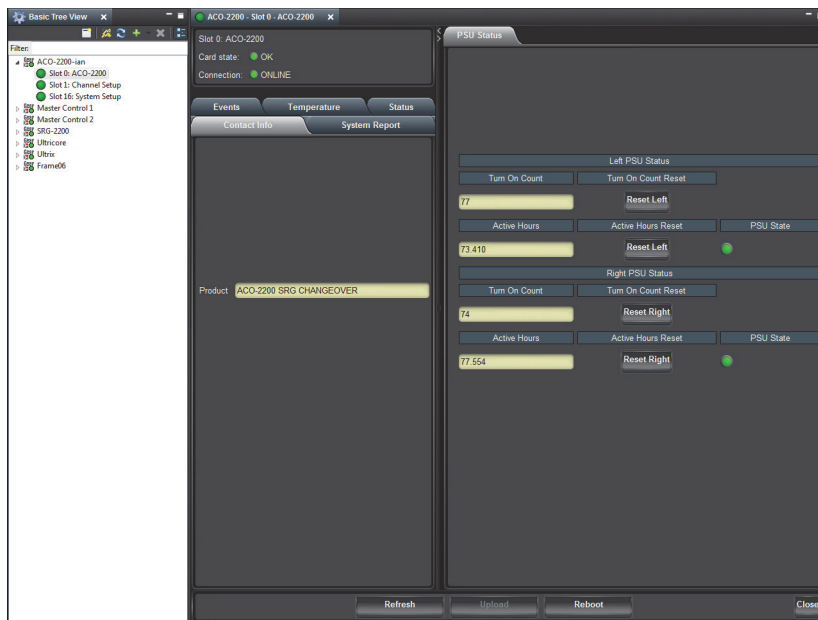

Initial Configuration

The ACO-2200 should arrive configured to a “factory default” condition, where all channels have:

- **Type** set to **Color Black**
- **Operational Mode** set to **Automatic**
- **Output** set to **Primary**

To ensure that you have a suitable channel configuration for the purposes of this Functional Check, you should perform the following procedures.

The procedures in this section assume that you have launched the DashBoard client and the ACO-2200 is displayed in the Tree View.

To select the number of active channels

1. Double-click the **Slot 1: Channel Setup** node.

The **Channel Setup** interface displays in the DashBoard window.

2. Select the **Configuration** tab.

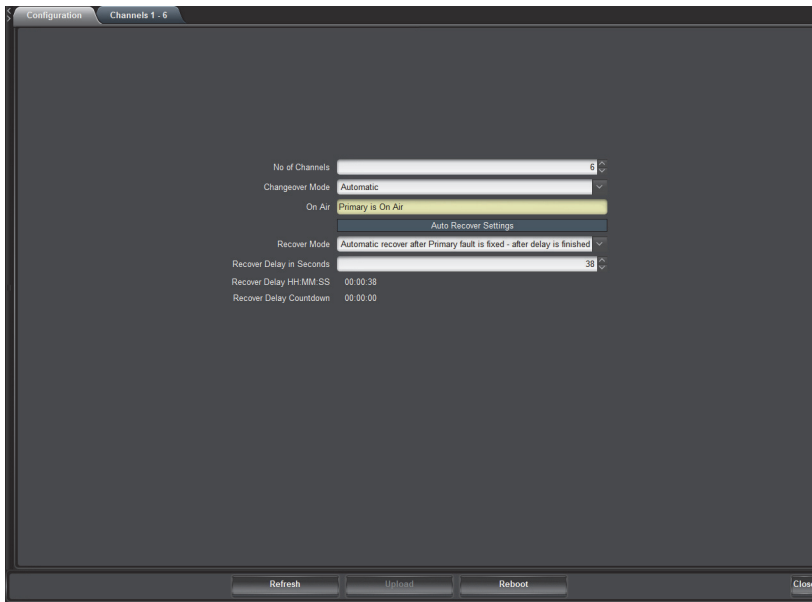

3. In the **No of Channels** field, set the number of channels. For initial configuration, select 1 channel.

To select the channel type(s)

1. Double-click the **Slot 1: Channel Setup** node.

The **Channel Setup** interface displays in the DashBoard window.

2. Select the **Channels 1-6** tab.

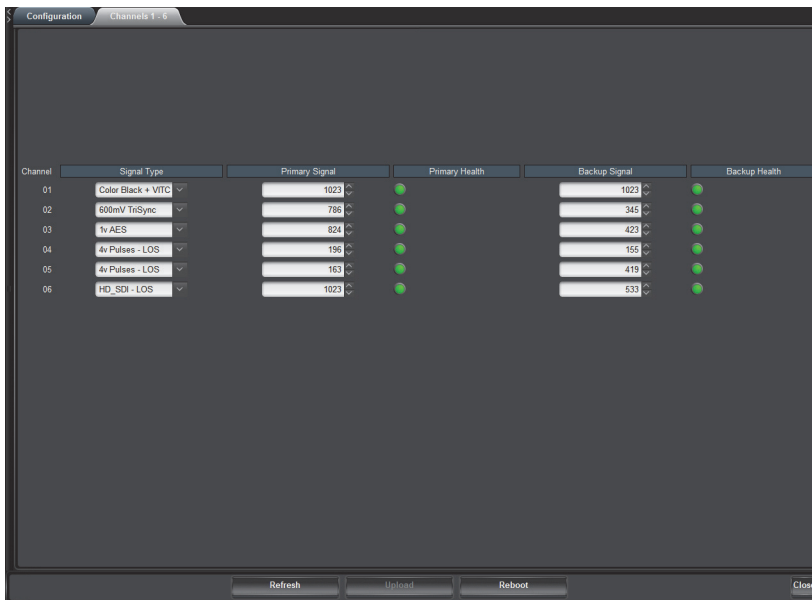

3. Select the channel to update. For initial configuration, select **Channel 1**.

4. Select the channel type from the drop-down menu. For initial configuration, select **Color Black**.

Performing Functional Checks

The procedures in this section assume that you have launched the DashBoard client and the ACO-2200 is displayed in the Tree View.

Normal Operation (No Faults)

1. Double-click the **Slot 1: Channel Setup** node.

The **Channel Setup interface** displays in the DashBoard window.

2. Select the **Configuration** tab.
3. Use the **Changeover Mode** menu to select **Automatic**.
4. Use the **On Air** menu to select **Primary is On Air**.

You should see that the channel output is the Primary input signal (Composite Video).

- ★ You cannot set the Output menu to Backup when the Operational Mode is set to Auto.

5. Use the **Changeover Mode** menu to select **Manual**.
6. Use the **On Air** menu to select **Backup is On Air**.

You should see that the channel output switches to the Backup input signal (Analog Color Black).

7. Use the **On Air** menu to select **Primary is On Air**.

The channel output switches to the Primary input signal (Composite Video)

Loss of the Primary Signal

1. Disconnect the Primary input signal (Composite Video).

- ★ The channel output automatically switches to the Backup input signal (Analog Color Black), and a fault indication appears on the display.

2. Re-connect the Primary input signal (Composite Video). Note that the fault indication changes to show that the Primary input signal is now correct, and the channel output automatically switches back to the Primary input signal (Composite Video).

3. Press [Push Button Control under FAULT LED] to clear the fault indication.

4. From DashBoard:

- a. Double-click the **Slot 1: Channel Setup** node.

The **Channel Setup interface** displays in the DashBoard window.

- b. Select the **Configuration** tab.

- c. Use the **Changeover Mode** menu to select **Manual**.

5. Disconnect the Primary input signal (Composite Video). Note that no switching occurs, but that the Primary fault indication appears.

6. Press [Push Button Control under FAULT LED] to clear the fault indication.

7. From DashBoard:

- a. Double-click the **Slot 1: Channel Setup** node.

The **Channel Setup interface** displays in the DashBoard window.

- b. Select the **Configuration** tab.

- c. Use the **Changeover Mode** menu to select **Backup**.

The channel output switches to the Backup signal (Analog Color Black).

8. Re-connect the Primary input signal (Composite Video).

9. From DashBoard:

- a. Double-click the **Slot 1: Channel Setup** node.

The **Channel Setup interface** displays in the DashBoard window.

- b. Select the **Configuration** tab.
- c. Use the **Changeover Mode** menu to select **Primary**.

The channel output switches to the Primary input signal (Composite Video).

10. From DashBoard:

- a. Double-click the **Slot 1: Channel Setup** node.

The **Channel Setup interface** displays in the DashBoard window.

- b. Select the **Configuration** tab.
- c. Use the **Changeover Mode** menu to select **Auto**.

Loss of Power

1. Turn off the power to one of the +12 VDC inlets. The associated fault indication appears in the display.
2. Restore power to the mains inlet. The fault indication changes to show that the “fault” is fixed.
3. Turn off the power to the other +12V DC inlet. The associated fault indication appears in the display.
4. Restore power to the mains inlet. The fault indication changes to show that the “fault” is fixed.
5. Turn off the power to both mains inlets. The channel output changes to the Primary input signal (Composite Video) and the unit powers down.

Operational Configuration

There are several configuration factors that will influence the initial installation of your ACO-2200. The following guidelines outline a typical example.

Power

The ACO-2200 will automatically switch to the Primary inputs whenever it loses power. So, you should connect the Backup SRG-2200 and one mains input on the ACO-2200 to the same power source, and connect the Primary SRG-2200 (and the second mains input on the ACO-2200) to a second power source. In these configurations, both power connections would have to fail before you lose control of the ACO-2200.

Signals

You should now configure the ACO-2200 according to your requirements, namely the number of channels to be monitored, and the signal type associated with each channel (using the procedures detailed in the previous Initial Configuration section of this manual).

When selecting the number of channels, you must always start from number 1, and continue up to the number of signals you wish to monitor. You should set any unused channels to “No Measurement”. If you select more active channels than you have signals connected, “Input Missing” errors will always be reported, leading to inconsistent operation.

You can now connect your signals to the ACO-2200 rear panel BNCs (**Figure 5.2** as an example), according to the configuration settings made in the previous paragraph. The example in **Figure 5.2** shows six channels from the list of supported signal types

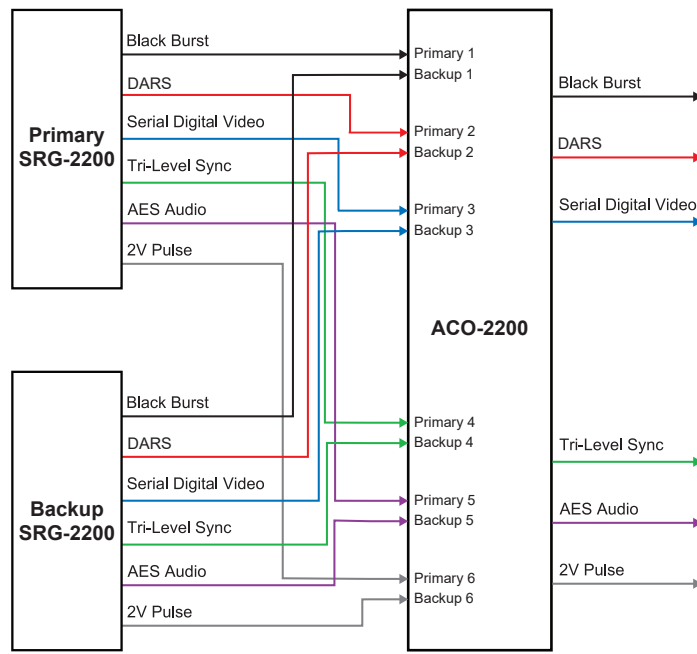

Figure 5.2 Example of ACO-2200 Connections

You should produce a master reference sheet, in order to log how each channel is configured and connected (an example is shown below in **Table 5.1**). This will be helpful to refer to in the future in order to quickly find out whether, for example, a previously unused channel requires a menu change relating to the new signal to be monitored.

Table 5.1 ACO-2200 Channel Configuration

Channel	Channel Type	Signal Attached
1		
2		
3		
4		
5		
6		

Operating Basics

Overview

The ACO-2200 can be thought of as an automatic multi-pole switch that actuates whenever an error is detected in any BNC signal channel. All channels will switch at the same time.

Any unused BNC input channel should be configured to disable error checking. If unused channels are not disabled, they will always produce error signals leading to improper operation.

Error threshold levels are pre-defined during initial testing, and are not adjustable.

Operating Modes

The ACO-2200 can be operated in one of two modes, selected from within DashBoard or directly from the Front Panel. The options are either Automatic or Manual control.

- When **Auto** is selected, the ACO-2200 will automatically switch if a fault is detected.
- When **Manual** is selected, the ACO-2200 will switch only when the operator manually selects between Primary and Backup. This can be achieved directly from the Front Panel or from the DashBoard interface.

Fault Reporting

There is LCD and LED indication for fault reporting on all channels. If a fault occurs in one of the configured channels on either the Primary or Backup input, the LCD and LED indicators will illuminate to report the fault. The fault reporting is persistent, i.e. even if the fault is only an intermittent one, the fault indicator will stay illuminated. If more than one fault exists, only the “first” one is reported, i.e. counting from the lowest numbered configured channel. As faults are repaired, the fault indicator displays the next faulty input/channel in the list, etc. Repairing the last fault will update the LCD display to show that the [last] fault has been fixed - clearing the fault indication will turn the LCD fault indication off.

Software Field Upgrades

This upgrade procedure outlines the steps necessary to upgrade the software programmed on the ACO-2200.

Before starting, ensure that you comply with the following requirements:

- Connect the ACO-2200 via an Ethernet cable to your local network;
- A PC, also connected via Ethernet to your local network, with the supplied update program(s) and associated data file(s) available - ideally, data file(s) should be located in the same folder as the associated update program;
- A power-cycle is required as part of a data file update - ensure that the unit is not in service during the update process.
- Ensure that you have the Application Image software. Application Image files are prefixed with “ArmFile”. Usually a load address and software version will be appended, e.g. “ArmFile_<load_address>_<software-version>.ata”.
- Requires that the ACO-2200 is in Bootload mode. When complete, a power re-boot is required.

Uploading the Software Files

To upload software files to a ACO-2200, the ACO-2200 needs to be in Bootload mode.

1. On your PC, run the “RossSystemUpdate_v#. #. #. #. exe” program.
2. Set the IP address and IP Mask to be the same as that of the ACO-2200 itself.
3. Select the **Get Mode** button. The status window should confirm the mode: “After Get mode, the device is in BOOT_mode.” displays in the window.
4. If the ACO-2200 is “not found”, check again that all connections have been made then try repeating the above procedure after powering down the ACO-2200, and then resuming from the update program start-up line.
5. If the ACO-2200 still cannot be found, contact Ross Video for further assistance.
6. Select the **Open File** button.
7. Select the relevant *.ata file.
8. Select the **Send to device** button. Upload of file takes approximately 1 minute.
9. Verify that the status messages window confirms that the upload was completed successfully. If not, select **Send to device** again.
10. Power cycle the ACO-2200.

Your ACO-2200 is now upgraded and ready for use.

DashBoard Menus

The ACO-2200 provides the user with a menu interface to control the functions and options of the instrument.

Slot 0 - ACO-2200 Tabs

Select the **Slot 0 - ACO-2200** node to view the general operational status, systems reports, and installed system files for the ACO-2200 unit.

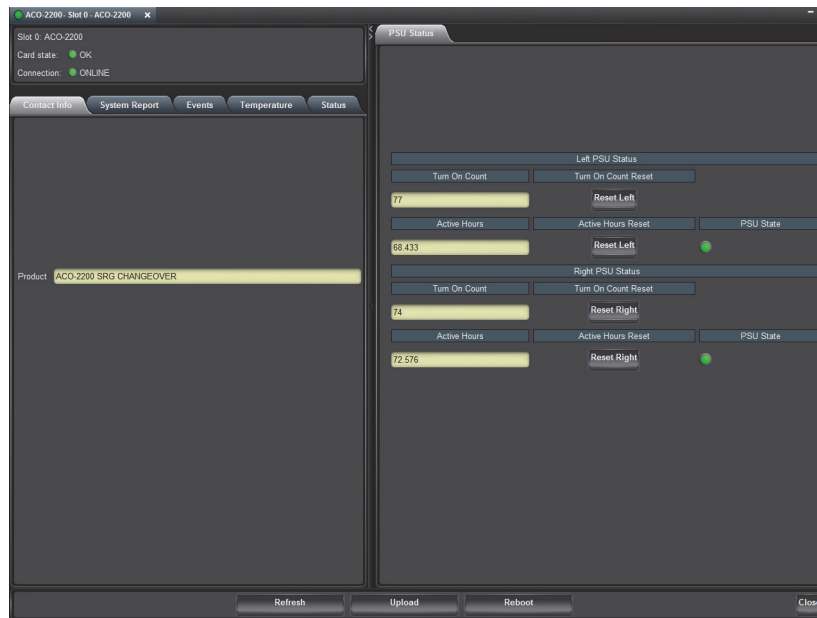

Figure 7.1 Example of the Slot 0 - ACO-2200 Tabs

System Report Tab

The **System Report** tab provides complete version information for the hardware, firmware and software elements that make up the ACO-2200.

Events Tab

The **Events** tab provides access to the last 99 events recorded by the ACO-2200. These events may relate to normal expected functionality or to systemic errors. This information might be useful in monitoring and diagnosing a system problem outside the ACO-2200, or a reliability problem within the ACO-2200. **Table 7.1** summarizes the possible events that can be recorded.

Table 7.1 Recordable Events

Event	Code	Event	Code
EventDefault	0	EventNewMaxTempAlarm1	27
Event Power On	1	EventNewMaxTempAlarm2	28
EventWatchdogReturn	2	EventNewMaxTempAlarm3	29
EventLVDRReturn	3	EventNewMaxTempAlarm4	30
EventPowerOff	4	EventNewMaxTempAlarm5	31
EventLVDEvent	5	EventNewMaxTempAlarm6	32
EventnSetUTCTimeFromGPS	6	EventNewMaxTempAlarm7	33

Table 7.1 Recordable Events

Event	Code	Event	Code
EventGPSTimeLost	7	EventNewMinTemp0	34
EventSetUTCtimeFromNTP	8	EventNewMinTemp1	35
EventNTPTimeLost	9	EventNewMinTemp2	36
EventLeftPSUfail	10	EventNewMinTemp3	37
EventLeftPSUreturn	11	EventNewMinTemp4	38
EventRightPSUfail	12	EventNewMinTemp5	39
EventRightPSUreturn	13	EventNewMinTemp6	40
EventPSULCDCancelManual	14	EventNewMinTemp7	41
EventPSULCDCancelAuto	15	EventNewMinTempAlarm0	42
EventPSULCDRepeatManual	16	EventNewMinTempAlarm1	43
EventPSULCDRepeatAuto	17	EventNewMinTempAlarm2	44
EventNewMaxTemp0	18	EventNewMinTempAlarm3	45
EventNewMaxTemp1	19	EventNewMinTempAlarm4	46
EventNewMaxTemp2	20	EventNewMinTempAlarm5	47
EventNewMaxTemp3	21	EventNewMinTempAlarm6	48
EventNewMaxTemp4	22	EventNewMinTempAlarm7	49
EventNewMaxTemp5	23	EventEthernetLinkMade	50
EventNewMaxTemp6	24	EventEthernetLinkLost	51
EventNewMaxTemp7	25	EventGPSSetTimecodeFromGPSFlag	52
EventNewMaxTempAlarm0	26	EventGPSUnSetTimecodeFromGPSFlag	53

Temperature Tab

The **Temperature** tab provides information on the temperature sensors within the ACO-2200. A typical example might look like: +3v3 Regulator 42 45 41

Depending on the exact configuration and options in the ACO-2200, only those sensors that are detected will be displayed. If a sensor is installed but has failed, the description in the relevant line appears as: N+1 Interface -Sensor absent.

Status Tab

The **Status** tab provides a full status report of the ACO-2200. The following status information is provided:

- Number of operational channels
- Changeover mode
- On-Air status
- Recovery mode
- Individual Channel Status for both Primary and Backup Channels

PSU Status Tab

The **PSU Status** tab, located on the right side of the **Slot 0 - ACO-2200** interface in DashBoard, displays read-only values for the number of times each power supply has been cycled, and the running hours count.

Slot 1 - Channel Setup Tabs

Select the **Slot 1 - Channel Setup** node to configure the personality of the ACO-2200 and to set up individual channels for the required input signal type to be measured.

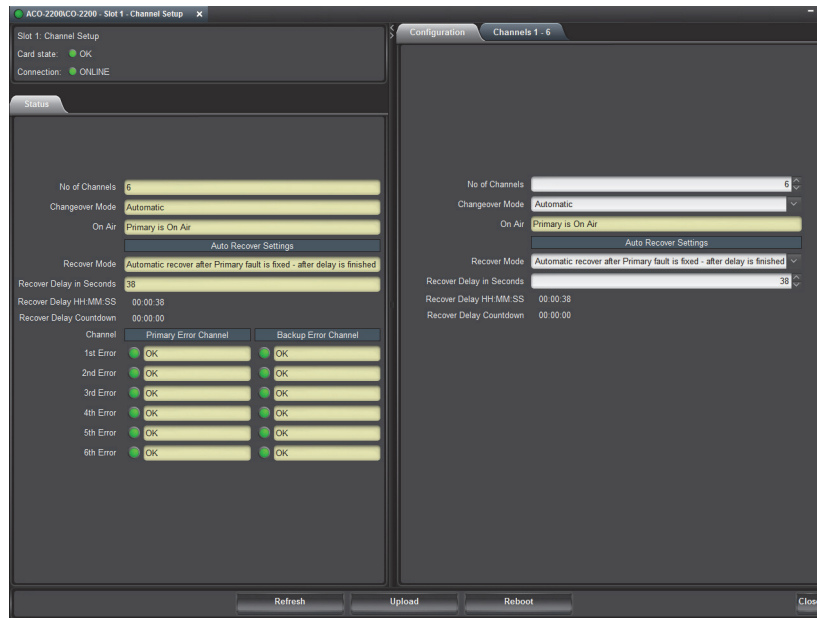

Figure 7.2 Example of the Slot 1 - Channel Setup Tabs

Status Tab

The Status tab reports the following information:

- the number of channels installed on the ACO-2200
- the current changeover mode
- whether the primary or backup SRG-2200 is on air

Auto Recover Settings

This area displays the following read-only fields:

- **Recover Mode** — indicates how the ACO-2200 is configured for recovery from faults.
- **Recovery Delay in Seconds** — indicates how many seconds the optional recovery delay is set for.
- **Recovery Delay in HHMMSS** — indicates how much time optional recovery delay is set for.
- **Recovery Delay Countdown** — when a fault occurs and is then fixed, if the ACO-2200 is set to auto recovery after delay, this timer shows the time until the ACO-2200 switches back to the Primary SRG-2200.

Primary Error Channel Status

Each field can display:

- a green indicator (OK) when there are no errors to report on the specified channel; or a
- red indicator for fault for each primary and backup channel.

Configuration Tab

Use the options in this tab to configure the ACO-2200.

Table 7.2 Configuration Items

Item	Parameter	Notes
No of Channels	#	Use this menu to specify the number of channels they want the ACO-2200 to monitor
Changeover Mode	Automatic	Allows the ACO-2200 to select primary or backup
	Manual	Allows the user to force the ACO-2200 to stay with either the primary or backup
On Air	#	This read-only field indicates whether the primary or backup is currently on air
Auto Recover Settings		
Recover Mode	Stay in backup mode	The ACO-2200 goes into manual mode with the backup routed to outputs.
	Automatically recover after the primary fault is fixed - immediately	This mode returns to the primary as soon as the ACO-2200 sees the primary signals have returned.
	Automatic recover after Primary fault is fixed - after delay is finished	This mode allows the user to set a time in seconds to delay the return to the primary SRG-2200. This can be set from 0 - 86399.
Recovery Delay	HH:MM:SS	Specifies how much time optional recovery delay is set for
Recovery Delay Countdown	HH:MM:SS	Specifies the running time until the ACO-2200 switches the primary SRG-2200 to air

Channels 1-6 Tab

Table 7.3 Configuration Items

Item	Parameter	Notes
Signal Type		Selects the type of signal that the specified channel is to measure
Primary Signal	#	Shows a relative signal amplitude and red or green for fault or no fault condition for the primary SRG-2200
Primary Health	#	
Backup Signal	#	Shows a relative signal amplitude and red or green for fault or no fault condition for the backup SRG-2200
Backup Health		

Slot 16 - System Setup Tabs

Select the **Slot 16 - System Setup** node to view the operational status of the ACO-2200, configure and monitor Network settings and status. It is also possible to view the factory Calibration settings.



Warning — Do not attempt to change these without factory guidance or assistance.

Network Tabs

The Network tab provides two sub-tabs: Ethernet and SNMP.

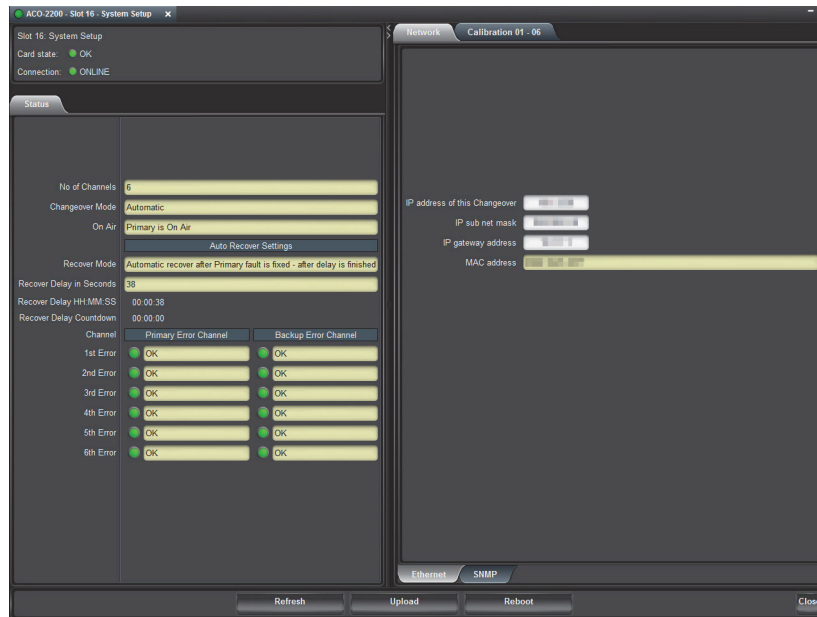

Figure 7.3 Example of Slot 16 - System Setup — Network Tabs

Ethernet Tab

The **E**thernet tab allows the user to configure and control the behavior of the Ethernet system within the ACO-2200. Before proceeding, the user must contact their Network Administrator, and obtain suitable IP addresses, etc., that will need to be programmed within this menu.

Table 7.4 Ethernet Items

Item	Parameter	Notes
IP address of this Changeover	#	This menu allows the user to enter the pre-determined IP address of the ACO-2200.
IP Sub Net Mask	#	This menu allows the user to enter the pre-determined SubNet Mask address of the ACO-2200
Gateway Address	#	This menu allows the user to enter the pre-determined Gateway address of the ACO-2200. Typically, this might be the IP address of a network hub to which the ACO-2200 is connected
MAC Address	#	This menu displays the MAC Address (Media Access Control), a unique, read-only identifier assigned to network interfaces for communications on the physical network segment. This value cannot be changed - the MAC address is stored in a hardware device. This address is unique to each ACO-2200, and is also used to provide unique update keys when enabling options within the unit.

SNMP Tab

This tab is not implemented.

Calibration 01 - 06 Tab

The **Calibration 01-06** tab enables the user to see the factory calibration data for the ACO-2200.

ACO-2200 - Slot 16 - System Setup

Network Calibration 01 - 06

Enable manual Calibration - Be careful

Channel	Signal Type	Primary No Signal	Primary Signal	Primary Fail	Backup No Signal	Backup Signal	Backup Fail
01	Color Black + VITC	905	805	864	902	798	859
02	60mV TriSync	905	805	865	906	802	863
03	1v AES	907	808	868	907	807	868
04	4v Pulses - LOS	907	808	868	906	803	865
05	4v Pulses - LOS	904	804	864	909	808	869
06	HD_SDI - LOS	902	805	863	910	808	869

Refresh Upload Reboot Close

Figure 7.4 Example of Calibration 01-06 Tab

Technical Specifications

This chapter lists the electrical, mechanical, and environmental characteristics, as well as the national and international standards to which the ACO-2200 complies.

★ Note that specifications are subject to change without notice.

General Characteristics

All listed specifications are guaranteed unless labeled with “Typical”. Typical specifications are provided for your convenience, but are not guaranteed.

Performance Conditions

The electrical characteristics listed on the following pages are valid under the following conditions:

- The ACO-2200 must be in an environment where the temperature, altitude, humidity, and vibration conditions are within the operating limits described in the section “**Environment Characteristics**” on page 34.
- The ACO-2200 must have a warm-up period of at least 20 minutes.
- The ACO-2200 must have been calibrated and adjusted at an ambient temperature between +20°C and +30°C.

BNC Channels

Table 8.1 Technical Specifications — BNC Channels

Category	Performance Requirement	Notes
Input Connector Type	3 x 75ohm BNC per channel	The non-selected input is automatically terminated
Return Loss (all inputs and outputs)	270Mbps: <-11dB	
	1.5Gbps: <-4dB	
	3Gbps: <-1.4dB	
Typical Amplitude	270Mbps: 800mV +/- 10%	
	1.5Gbps: 780mV +/- 10%	
	3Gbps: 660mV +/- 10%	
Typical Rise & Fall Time	270Mbps: 600ps/595ps +/- 10%	
	1.5Gbps: 155ps/145ps +/- 10%	
	3Gbps: 135ps/130ps +/- 10%	
Maximum Switched Voltage	30V DC (30V AC)	
Maximum Switched Current	0.5A	
Relay Switch Time	Based on Relay characteristics: <ul style="list-style-type: none">• Set time: typ. 3.5 ms,• Release time: typ. 2.5 ms,• Set/Release: max. 10mS	
Insertion Delay	<1ns	

Ethernet Interface

Table 8.2 Technical Specifications — Ethernet

Category	Performance Requirement	Notes
Connector Type	1 x RJ45 - 8P8C	
IEEE Standards Compliance	IEEE 802.31-1990	10BASE-T
	IEEE 802.3u-1995	100BASE-TX

DC Power Source

Table 8.3 Technical Specifications — DC Power Source

Category	Performance Requirement	Notes
Operational Voltage Range	10-13 VDC	
Absolute Limits Voltage Range	9-14VDC	
Operational AC Current	0.74A	
Power Consumption	9VA	

Physical Specifications

Clearance

Table 8.4 Technical Specifications — Clearance

Category	Performance Requirement	Notes
Side	50mm (2.00")	
Rear	75mm (3.00")	

Mechanical Characteristics

Table 8.5 Technical Specifications — Mechanical

Category	Performance Requirement	Notes
Height	43.5 mm (1.71")	
Width	482.5 mm (19.00")	
Depth	235 mm (9.25")	

Environment Characteristics

Table 8.6 Technical Specifications — Environmental

Category	Performance Requirement	
Temperature	Operating	0°C to +40°C
	Non-operating	-20°C to +60°C

Table 8.6 Technical Specifications — Environmental

Category	Performance Requirement	
Relative Humidity	Operating	20% to 80% relative humidity (%RH) at up to +40°C, non-condensing
	Non-operating	5% to 90% relative humidity (%RH) at up to +60°C, non-condensing
Altitude	Operating	To 2,000m (6,561ft)
	Non-operating	To 12,192m (40,000ft)
Vibration	Operating	2.65m/s ² (0.27Grms), 5Hz to 500Hz, 10 minutes per axis, three axes
	Non-operating	22.3m/s ² (2.28Grms), 5Hz to 500Hz, 10 minutes per axes, three axes
Shock	Non-operating	294m/s ² (30G), half-sine, 11ms duration

Service Information

Generally speaking, the ACO-2200 is reliable under normal steady-state operating conditions. If you are having problems, select the symptom from the list in this chapter that closely relates to your particular problem, and perform the checks / actions listed.

This chapter also contains procedures for cleaning and performing preventive maintenance on the ACO-2200, general servicing information, and the warranty policies.



Notice — *Observe all cautions and warnings listed in the document “Important Regulatory and Safety Notices to Service Personnel” that was included with your unit.*

User Maintenance

This section contains information for cleaning and performing preventive maintenance on the ACO-2200.

General Care

Protect the instrument from adverse conditions, i.e. high humidity, high temperatures, etc. The instrument is NOT waterproof.

When handling the unit or any of its controls, do so with clean hands.

Do not use excessive force to operate any of the controls on the unit.

Exterior Cleaning

Clean the instrument periodically to prevent the accumulation of dust or dirt. Accumulated dust in the instrument acts like an insulating blanket, preventing proper cooling, resulting in overheating and ultimately premature component breakdown. Under high humidity conditions, accumulated dust can also result in an electrically conductive path.



Warning — *To avoid personal injury, always remove the power cord before cleaning the instrument.*

A vacuum cleaner may be used to remove accumulated dust on the outside of the instrument. Ensure that the nozzle is fitted with a soft brush head (or similar) to avoid damaging the instrument.



Caution — *Avoid exposing the instrument to liquids, sprays or solvents, as this could damage the unit. Cleaning agents may also damage the instrument. Avoid solutions that contain harmful chemicals such as Acetone, Benzene, Toluene, Xylene, or similar.*

If the exterior surfaces or controls of the instrument require further cleaning, use a dry, lint- free cloth or a soft-bristle brush. If dirt remains, use a cloth or swab dampened with a 75% isopropyl alcohol solution. A swab is useful for cleaning in narrow spaces around the controls and connectors. Do not use excessive amounts of the approved cleaning solution when cleaning the instrument. Do not use abrasive compounds on any part of the instrument.



Caution — *Do not allow moisture or dust to enter the instrument during exterior cleaning. Only use enough solution to mildly dampen a cloth or similar. After cleaning, use de-ionized water on a clean cloth to rinse the instrument.*

Preventive Maintenance

Preventive Maintenance mainly consists of periodic cleaning. Periodic cleaning reduces instrument breakdown and increases reliability. Clean the instrument whenever needed (using the guidelines outlined above), based on the operating environment. Dirty conditions may require more frequent cleaning than a conventional clean room environment.

Servicing

The ACO-2200 should require little or no in-service maintenance to the installed electronics. Provided the measures outlined in the section “**Preventive Maintenance**” on page 38 are adhered to, the product should perform for several years without any major user intervention.

Maintenance of components within the product is not usually required, except under exceptional circumstances. If a fault occurs, please follow the instructions listed in the section “**Troubleshooting Checklist**” on page 39 before attempting to service the product. The servicing of any of the internal components requires the unit to be extracted from the bay and the top cover removed. If your problem cannot be resolved, contact Ross Video for further advice.

If you ordered a Service Option, then removing the unit from the bay and returning it to Ross Video for updating will provide the user with the opportunity to inspect the unit for any problems relating to the operating conditions/environment.

Service Safety Overview

Only qualified personnel should perform service procedures. Read this section before performing any service procedures.

- **Do Not Service Alone.** Do not perform internal service or adjustments of this product unless another person capable of rendering first aid and resuscitation is present.
- **Disconnect Power.** To avoid electric shock, switch off the power to the instrument, then disconnect the power cord from the mains power.
- **Use Care When Servicing With Power On.** Dangerous voltages or currents may exist in this product. Disconnect power, remove battery (if applicable), and disconnect test leads before removing protective panels, soldering, or replacing components.
- **Observe Static Precautions.** Servicing of this product should be performed only in a static-safe environment, i.e. at a suitably configured ESD Workstation. Always use a Static Grounding Wrist-Strap connected to the ESD Workstation mat while servicing the product.
- To avoid electric shock, do not touch exposed connections.

Important Information Regarding the use of Switch Cleaners

Switch Cleaner products usually contain a lubricating additive (along with the alcohol-based propellant), intended to remain after spraying into relevant components.

Some equipment produced by Ross Video contains components that should not be cleaned using these types of cleaners, due to the compact nature of the components, their operating characteristics, or their inaccessibility. This is because push-buttons, for example, rely on clean, dry, conductive contact surfaces to operate correctly. Applying Switch Cleaner lubricant only serves to attract dust, or worse still could wash-in grease and dust, which could severely reduce the conductivity of the component parts.

Therefore, Ross Video does not recommend the use of these Switch Cleaner products on their equipment, and will not be held liable for any fault caused by inadvertent or unqualified use or application of such products.

Troubleshooting Checklist

Routine maintenance to this Ross Video product is not required. In the event of problems with your ACO-2200, the following basic troubleshooting checklist may help identify the source of the problem. If the frame still does not appear to be working properly after checking all possible causes, please contact your Ross Video products distributor, or the Technical Support department at the numbers listed under the “**Contact Us**” section.

1. **Visual Review** — Performing a quick visual check may reveal many problems, such as connectors not properly seated or loose cables. Check the card, the frame, and any associated peripheral equipment for signs of trouble.
2. **Power Check** — Check the power indicator LED on the distribution frame front panel for the presence of power. If the power LED is not illuminated, verify that the power cable is connected to a power source and that power is available at the power main. Confirm that the power supplies are fully seated in their slots. If the power LED is still not illuminated, replace the power supply with one that is verified to work.
3. **Input Signal Status** — Verify that source equipment is operating correctly and that a valid signal is being supplied.
4. **Output Signal Path** — Verify that destination equipment is operating correctly and receiving a valid signal.

Contacting Ross Video Technical Support

If your problem is not resolved after following these checks / actions, the fault is likely to be related to a mechanical or electrical component failure. Contact Ross Video for further assistance.

When you contact Ross Video regarding an issue on your ACO-2200, and so that we can process your inquiry efficiently, you should have available at least one of the following items of information in addition to your personal / company details (name, company, telephone, email):

- the frame serial number of the unit
- original delivery date

Warranty and Repair Policy

The ACO-2200 is warranted to be free of any defect with respect to performance, quality, reliability, and workmanship for a period of ONE (1) year from the date of shipment from our factory. In the event that your ACO-2200 proves to be defective in any way during this warranty period, Ross Video Limited reserves the right to repair or replace this piece of equipment with a unit of equal or superior performance characteristics.

Should you find that this ACO-2200 has failed after your warranty period has expired, we will repair your defective product should suitable replacement components be available. You, the owner, will bear any labor and/or part costs incurred in the repair or refurbishment of said equipment beyond the ONE (1) year warranty period.

In no event shall Ross Video Limited be liable for direct, indirect, special, incidental, or consequential damages (including loss of profits) incurred by the use of this product. Implied warranties are expressly limited to the duration of this warranty.

This ACO-2200 User Manual provides all pertinent information for the safe installation and operation of your Ross Video Product. Ross Video policy dictates that all repairs to the ACO-2200 are to be conducted only by an authorized Ross Video Limited factory representative. Therefore, any unauthorized attempt to repair this product, by anyone other than an authorized Ross Video Limited factory representative, will automatically void the warranty. Please contact Ross Video Technical Support for more information.

In Case of Problems

Should any problem arise with your ACO-2200, please contact the Ross Video Technical Support Department. (Contact information is supplied at the end of this publication.)

A Return Material Authorization number (RMA) will be issued to you, as well as specific shipping instructions, should you wish our factory to repair your ACO-2200. If required, a temporary replacement frame will be made

available at a nominal charge. Any shipping costs incurred will be the responsibility of you, the customer. All products shipped to you from Ross Video Limited will be shipped collect.

The Ross Video Technical Support Department will continue to provide advice on any product manufactured by Ross Video Limited, beyond the warranty period without charge, for the life of the equipment.

Glossary

The following terms are used throughout this guide:

- “**Almanac**” refers to a set of parameters included in the GPS satellite navigation message that a receiver uses to predict the approximate location of a satellite. The almanac contains information about all of the satellites in the constellation.
- “**CW signals**” refers to continuous wave signals.
- “**Ephemeris**” is a description of the path of a celestial body indexed by time. The navigation message from each GPS satellite includes a predicted ephemeris for the orbit of that satellite valid for the current hour. The ephemeris is repeated every 30 seconds and is in the form of a set of 16 Keplerian-like parameters with corrections that account for the perturbations to the orbit caused by the earth’s gravitational field and other forces.
- “**Epoch**” is an instant of time (or a date) from which values of data are referenced. Note: an Era is the period of time between successive epochs.
- “**GLONASS**” refers to the Global Navigation Satellite System.
- “**GPS**” refers to global positioning system.
- “**Operator**” and “**User**” refer to the person who uses ACO-2200.
- “**RF interference**” refers to radio frequency interference
- “**System**” and “**Video system**” refer to the mix of interconnected production and terminal equipment in your environment.
- “**UTC**” refers to Co-ordinated Universal Time. The time scale based on the atomic second but occasionally corrected, by the insertion of leap seconds, to keep it approximately synchronized with Earth’s rotation. The leap second adjustments keep UTC within 0.9 seconds UT1.

