ROSS VIDEO LIMITED

PAA-7803
Programmable Audio Amplifier

USER MANUAL

7803-PAA-01-MNL
Issue 1



PAA-7803 • Programmable Audio Amplifier – User’s Manual

- Ross Part Number: **7803-PAA-01-MNL**
- Document Issue: **1**
- Printing Date: December 2, 2002. Printed in Canada.

The information contained in this guide is subject to change without notice or obligation.

Copyright

. All rights reserved.

Contents of this publication may not be reproduced in any form without the written permission of Ross Video Limited. Reproduction or reverse engineering of copyrighted software is prohibited.

Notice

The material in this guide is furnished for informational use only. It is subject to change without notice and should not be construed as commitment by Ross Video Limited. Ross Video Limited assumes no responsibility or liability for errors or inaccuracies that may appear in this manual.

Trademarks

-  is a registered trademark of Ross Video Limited.
- Ross, ROSS, ROSS® and RossGear are registered trademarks of Ross Video Limited.
- All other product names and any registered and unregistered trademarks mentioned in this guide are used for identification purposes only and remain the exclusive property of their respective owners.

Company Address



Ross Video Limited

8 John Street
Iroquois, Ontario, K0E 1K0
Canada

Ross Video Incorporated

P.O. Box 880
Ogdensburg, New York
USA 13669-0880

General Business Office: (+1) 613 • 652 • 4886

Fax: (+1) 613 • 652 • 4425

Customer Service: (+1) 613 • 652 • 4886

E-mail (Customer Support): tech-support@hq.rossvideo.com

E-mail (General Information): solutions@rossvideo.com

Website: <http://www.rossvideo.com>

After hours emergency: (+1) 613 • 652 • 4886, ext. 333

PAA 7803 BLOCK DIAGRAM

Issue 1

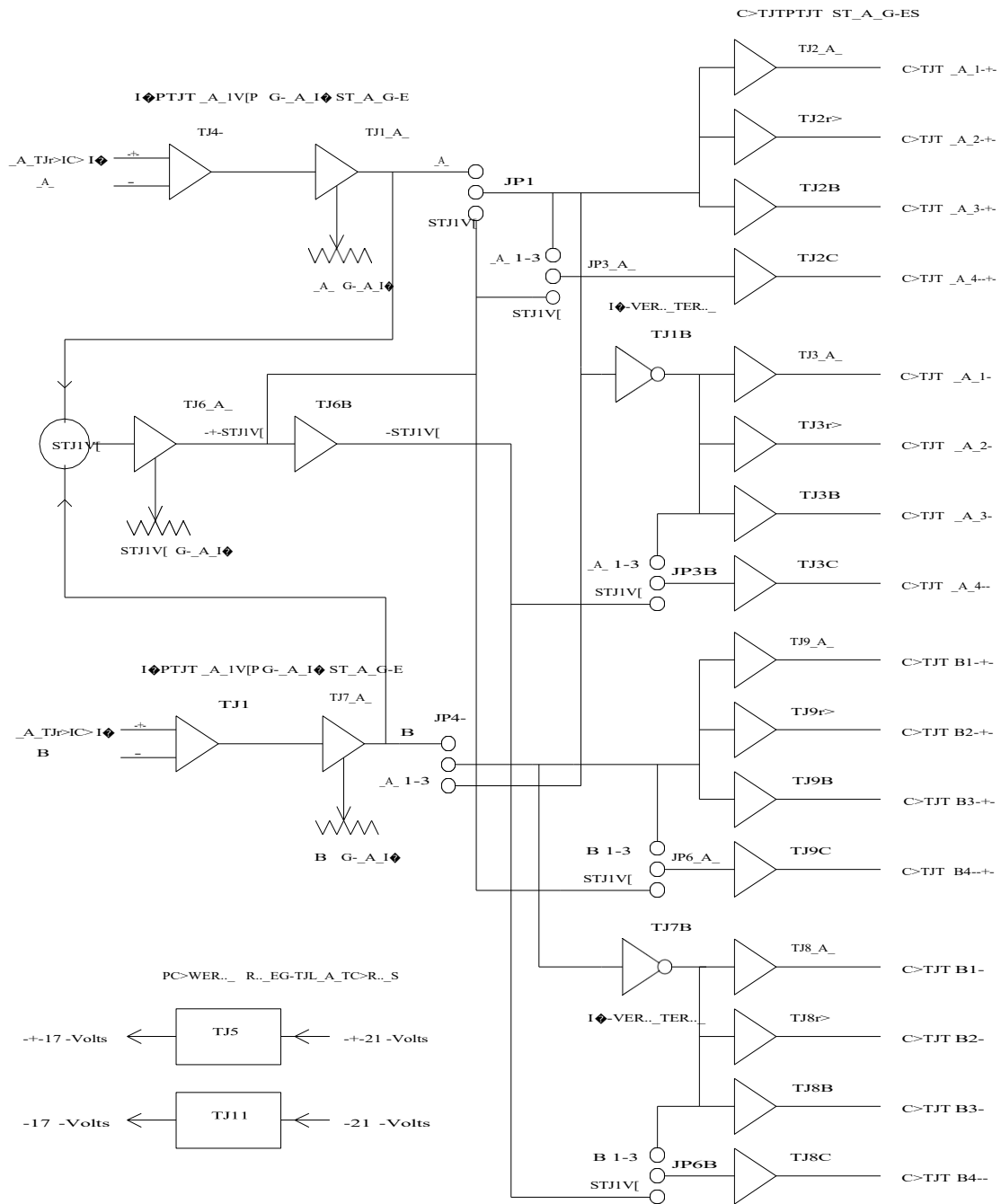

Introduction

The Ross PAA-7803 Stereo Distribution Amplifier provides a means of amplifying and distributing program-level stereo audio with virtually no loss of quality. Use of the latest types of integrated circuits which are developed specifically suited to professional audio applications assures a very low level of distortion and noise.

The circuit board contains two identical amplifiers which can be used for stereo distribution or as two independent four-output mono amplifiers. A jumper plug enables the amplifiers to be operated as a single eight-output amplifier.

Installation and Operation

The input and output cables should be connected to the frame terminals by following the chart for STEREO connections, located at the left rear of the frame. Normally, the cable shield grounds are connected in the case of outputs but left floating in the case of inputs to avoid ground loop currents. Otherwise, follow local wiring practice.

Programming the amplifier to match the application involves setting four sets of jumper plugs to obtain the desired amplifier function in accordance with the following illustrations.

1) Stereo amplifier, 8 outputs per channel

Outputs A1 to A4 come from the A input. Outputs B1 to B4 come from the B input. The SUM GAIN Control has no function.

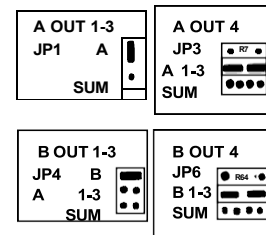

2) Mono amplifier, 8 outputs

Outputs A1 to A4 and B1 to B4 come from the A input. The SUM GAIN and B GAIN controls have no function.

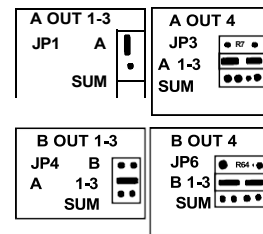

3) Stereo Amplifier, 3 outputs per channel plus 2 summed (Mono) outputs

Stereo outputs are A1 to A3, B1 to B3. The summed outputs are A4 and B4. All gain controls function.

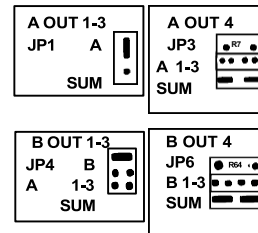

4) Summing Amplifier, 8 outputs

All outputs are summed (mono). All gain controls function.

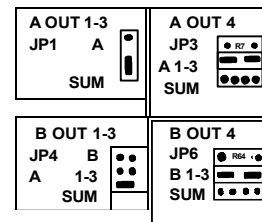

The A GAIN and B GAIN jumpers should be set appropriately for the input signal level. Normally they will be set to the 0 dB position. The card-edge gain controls should be set to obtain the desired signal output level.

Circuit Description

The A input stage, U4, performs the function of converting the balanced input signal into an unbalanced (single ended) signal for further processing.

This stage is unique because it functions exactly as if the amplifier had a floating transformer input. This means that it responds only to the voltage difference between the two input lines and ignores any imbalance to ground. This gives the distribution amplifier the very desirable ability to accept any out-of-balance input signal and produce a perfectly balanced output. As a consequence, it also has an exceptional ability to reject common mode hum and noise over the whole audio band.

The input circuit includes diodes to protect the amplifier against damaging input noise spikes.

The amplifier gain is provided by circuit U1A. JP2 selects the desired gain range and RV1 provides vernier gain adjustment.

The input circuit for the B channel is identical to that for the A channel and involves U10 and U7A.

The A and B signals are resistively summed and amplified by U6A which provides a negative signal output. Phase inverter U6B provides the positive signal. The gain of the summed signal is adjusted by RV3.

Positive line outputs 1-3 are driven by unity-gain stages U2A, U2D and U2B. These circuits are designed to be very stable and not oscillate at any normal line load. The negative output stages U3A, U3D and U3B are driven by unity-gain inverter U1B. These outputs are driven by the output of jumper JP1 which selects the A signal or the summed signal.

The fourth output is driven separately via jumper JP3 which selects the main output signal (outputs 1-3) or the output of the summing amplifier.

The second set of outputs is similar to the above and involves U9, U7B and U8.

The power input voltage of approximately +/- 20 volts is reduced to +/- 17 volts by regulators U8 and U9. This lower voltage powers the input and gain stages while the output stages are fed directly from the power supply.

Alignment

The only alignment controls provided are for balancing the common-mode rejection of the input amplifiers. To adjust the A INPUT BAL control, make the indicated connections to the terminal block associated with the particular amplifier.

NOTE:

Because this control has been precisely calibrated at the factory, it must not be adjusted unless U4 or U10 have been replaced.

1. Place the amplifier on the extender board.
2. Use a short jumper wire to connect the frame A INPUT plus and minus terminals together.
3. Connect an audio generator between either frame A input and ground. Set the generator frequency to 1 KHz and output level to +20 dBu.
4. Connect a balanced-input sensitive audio level meter or distortion analyser to a balanced pair of amplifier outputs.
5. With the output level meter set to the most sensitive scale, adjust the A INPUT BAL potentiometer to obtain the lowest possible output level. It should be possible to obtain an output level of at least -90 dBu. (110dB below +20 dBu). Seal the pot.
6. Proceed in a similar manner to set the B BAL pot.
7. Disconnect the test set up.

Specifications

Input	Input Impedance	>35 Ω , balanced
	Max Input Level	+34 dBu [+30 dBm]
	Common Mode Rejection	>110 dB @ 60 Hz >80 dB @ 20 KHz
Output	Number of Outputs	8 total
	Max Output Level	+28 dBu [+24 dBm]
	Output Impedance	66 Ω , [600 Ω]
	Output Isolation	>70 dB
Performance	S/N Ratio	>100 dB (unity gain) relative to +8 dBu
	Gain Range	-6 to +34 dB (\pm 6 dB fine adjustment)
	Summing Gain Range	\pm 6 dB
	Frequency Response	+/- 0.02 dB 20 Hz to 20 KHz
	Total Harmonic Distortion + Noise	<0.002%
	Intermodulation	<0.002% (SMPTE)
	Crosstalk between Amplifiers	>100 dB
	Interchannel Crosstalk	>95 dB
	Power Consumption @ +8 dBu output	2.5 W [3.5 W]
All tests performed at +18 dBu and cover 20 Hz to 20 KHz unless otherwise specified. All measurements made with an Audio Precision System One test set. Performance of the 600 ohm version is similar, except where indicated [].		

PAA 7803
Bill Of Materials

7803A-001 Issue 1

Item	QTY	REF	Part	Description	Part Number
1	1	J1	CON30P156E	NOT A BOUGHT PART	-----
2	2	R28,R47	NVR	NO VALUE RESISTOR 5%	-----
3	16	R1,R9,R11,R13,R15,R38, R40,R42,R68,R70,R72,R74, R85,R87,R89,R91	NVR 1%	NO VALUE RESISTOR 1%	-----
4	2	TP4,TP2	NVTP	NO VALUE TEST POINT	-----
5	2	C28,C29	1p	CAPACITOR CERAMIC 100V 0.25PF 1p	200-100
6	2	C18,C9	22p	CAPACITOR CERAMIC 100V 2% 22p	201-220
7	7	C3,C4,C7,C16,C21,C24,C25	47p	CAPACITOR CERAMIC 100V 2% 47p	201-470
8	10	C5,C6,C10,C11,C15,C17, C19,C20,C26,C27	100n	CAPACITOR GLASS 100n	225-100
9	4	C1,C2,C13,C14	100u 250-005	CAPACITOR TANTALUM 6.3V 100u	250-005
10	4	C8,C12,C22,C23	6u8	CAPACITOR TANTALUM 25V 6u8	250-008
11	8	CR1,CR3,CR4,CR5,CR6,CR7, CR8,CR9	1N4148	DIODE SIGNAL GP 1N4148	360-005
12	2	CR2,CR10	1N4742A	DIODE ZENER 1N4742A	360-019
13	1	MP1	365-001	PCB EJECTOR	365-001
14	1	JP4	403-004-06	HEADER 6 PIN 2 ROW MALE PL.23 BL.1 LL.1	403-004-06
15	4	JP2,JP3,JP5,JP6	403-004-08	HEADER 8 PIN 2 ROW MALE PL.23 BL.1 LL.1	403-004-08
16	1	JP1	403-013-03	HEADER 3 PIN 1 ROW MALE PL.23 BL.1 LL.1	403-013-03
17	1	U5	LM78L05	POSITIVE VOLTAGE REGULATOR	500-024
18	1	U11	LM79L05	NEGATIVE VOLTAGE REGULATOR	500-025
19	3	U1,U6,U7	NE5532N	INT-COMPENSATED DUAL LO-NOISE OP AMP	504-129
20	2	U10,U4	SSM-2143P	-6dB DIFFERENTIAL LINE RECEIVER	504-130
21	4	U2,U3,U8,U9	TLE2064CN	JFET-INPUT HIGH-OUT POWER QUAD OP AMP	504-155
22	8	JPPLUG1,JPPLUG2,JPPLUG3B, 603-005 JPPLUG3A,JPPLUG4,JPPLUG5, JPPLUG6B,JPPLUG6A		JUMPER 2-POSITION LOW PROFILE	603-005
23	2	RV5,RV2	100R 1T	VARIABLE RESISTOR 1/4 DIA 1-TURN 100R	710-002
24	3	RV1,RV3,RV4	10K 720-002	VARIABLE RESISTOR 20-TURN 10K	720-002
25	1	PCB	7803-001-01	PROGRAMMABLE SUMMING AUDIO AMP PCB	7803-001-01
26	2	F2,F1	1R 1%	RESISTOR 1/4W 1% 1R	810-100
27	2	R29,R50	53R6 1%	RESISTOR 1/4W 1% 53R6	811-536
28	2	R30,R51	191R 1%	RESISTOR 1/4W 1% 191R	812-191
29	2	R60,R31	750R 1%	RESISTOR 1/4W 1% 750R	812-750
30	1	R49	2K49 1%	RESISTOR 1/4W 1% 2K49	813-249
31	16	R2,R10,R12,R14,R16,R39, R41,R43,R69,R71,R73,R75, R86,R88,R90,R92	4K75 1%	RESISTOR 1/4W 1% 4K75	813-475
32	8	R6,R32,R33,R34,R52,R55, R63,R83	10K 1%	RESISTOR 1/4W 1% 10K	814-100
33	2	R24,R82	52K3 1%	RESISTOR 1/4W 1% 52K3	814-523
34	4	R8,R36,R66,R67	4R7	RESISTOR 1/2W 5% 4R7	824-470
35	16	R3,R17,R18,R19,R20,R44, R45,R46,R76,R77,R78,R79, R93,R94,R95,R96	33R	RESISTOR 1/2W 5% 33R	825-330
36	2	R25,R58	47R	RESISTOR 1/2W 5% 47R	825-470
37	7	R7,R27,R37,R48,R53,R64, R84	1K	RESISTOR 1/2W 5% 1K	827-100
38	2	R5,R62	1K5	RESISTOR 1/2W 5% 1K5	827-150
39	2	R26,R59	2K7	RESISTOR 1/2W 5% 2K7	827-270
40	4	R21,R54,R56,R57	4K7	RESISTOR 1/2W 5% 4K7	827-470
41	2	R65,R35	10K	RESISTOR 1/2W 5% 10K	828-100
42	2	R61,R4	12K	RESISTOR 1/2W 5% 12K	828-120
43	4	R22,R23,R80,R81	10K 0.5%	RESISTOR 1/4W 0.5% 10K	840-059
44	3	TP1,TP3,TP5	910-010	TEST POINT	910-010

THESE DRAWINGS AND SPECIFICATIONS ARE THE PROPERTY OF ROSS VIDEO LIMITED AND SHALL NOT BE REPRODUCED OR COPIED OR USED AS THE BASIS FOR THE MANUFACTURE OR SALE OF ANY DEVICE WITHOUT PERMISSION. © 1995

SQUARE PIN DESIGNATIONS:
 INTEGRATED CIRCUIT = PIN 1
 TRANSISTOR = EMITTER
 DIODE = CATHODE (BAR)
 POLARIZED CAPACITOR = POSITIVE PIN (+)
 RESISTOR NETWORK = PIN 1

IN HV HOLE DIMENSION (1/16" IN. BY TEST)
 L= POSITIVE (W/ LONG LEG)

REVISION RECORD

- JP1 = A OUT 1-3 A / SU1.1
- JP1 = A GAIN 0dB
- JP3 = A OUT 4 A 1-3
- JP4 = B OUT 1-3 A 1-3
- JP5 = B GAIN 0dB
- JP6 = B OUT 4 A 1-3 SUM
- RV1 = A GAIN
- RV2 = A INPUT BALANCE
- RVJ = SIN GAIN
- = B GAIN
- RV5 = B INPUT BALANCE
- TP1 = A1+
- TP2 = +HV
- TP3 = OUT B+
- TP4 = -17V
- TP5 = GND

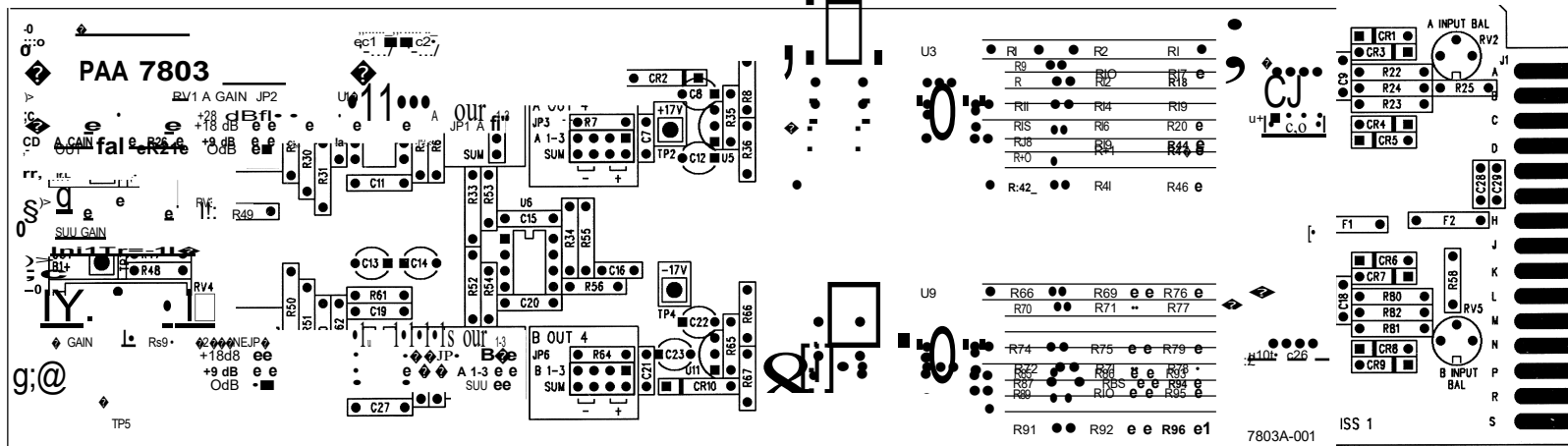

ROSS VIDEO LIMITED		DESIGN	APPROVED BY	RELEASED BY
PROGRAMMABLE AUDIO A/P	PAA-7803	780JA-001	01	1 of 1

B

5

2

THESE DRAWINGS AND SPECIFICATIONS ARE THE PROPERTY OF ROSS VIDEO LIMITED AND SHALL NOT BE REPRODUCED OR COPIED OR USED AS THE BASIS FOR THE MANUFACTURE OR SALE OF APPARATUS WITHOUT PERMISSION. © 1995

INPUT-7 r----- -1

GAIN ADJUST & SUM

OUTPUTS

EDGE CONNECTOR

POWER

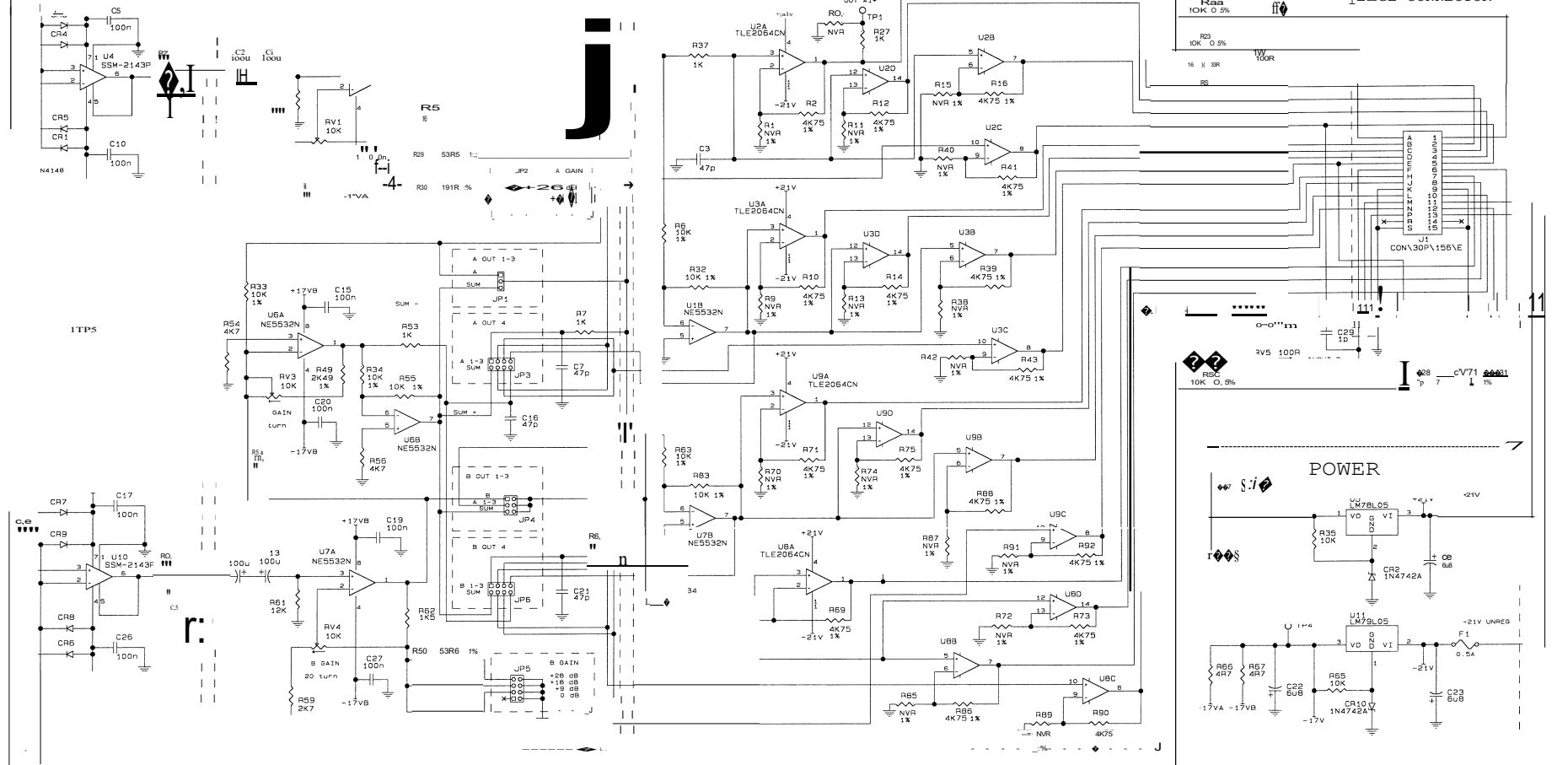

Power Consumption
+18 DBU Out: 29.1

ROSS VIDEO LIMITED		FILE 001-01: SCH		DATE 11.1.95	
DRAWN BY	DESIGNED BY JR	APPROVED BY OM	RELEASED BY	DATE 11.1.95	
PAA-7803		NUM 7803A-00 1	SHEET 1	1 OF 1	

RossGear Terminal Equipment • Warranty and Repair Policy

This **RossGear Terminal Equipment** product is warranted to be free of any defect with respect to performance, quality, reliability and workmanship for a period of FIVE (5) years from the date of shipment from our factory.

In the event that your **RossGear** product proves to be defective in any way during this warranty period, we will gladly repair or replace this piece of equipment with a unit of equal or superior performance characteristics.

Should you find that this **RossGear** product has failed after your warranty period has expired, we will repair your defective piece of equipment for as long as suitable replacement components are available. You, the owner, will bear any labor and/or component costs incurred in the repair or refurbishment of said equipment, beyond the **FIVE (5)** year warranty period.

Should your **RossGear** product be of our **Digital Terminal Equipment** product line, a power supply, or product with surface mount devices, and it proves to be defective, we would ask that an authorized **Ross Video Limited** factory representative repair the product. Any attempt to repair this product by anyone other than an authorized **Ross Video Limited** factory representative, will void your warranty.

If this is a manual for a **RossGear** product of our **Digital Terminal Equipment** product line, a power supply, or piece of equipment that carries surface mount devices, you will find it provides all pertinent information for the safe installation and operation of your **RossGear** product.

If this is a manual for a **RossGear** product from our **Analog Terminal Equipment** product line, you will find it provides all pertinent information for the safe installation and operation of your **RossGear** product. Included in this manual (if this product does not carry any surface mount devices) you will also find schematics, bills of materials and layout drawings. These are provided for your convenience, should you find it necessary to perform discretionary field repair or modifications to your **RossGear** product.

Ross Video Limited reserves the right to assess any modifications or repairs made by you and decide whether they fall within warranty limitations, should you decide to return your **RossGear** product for repair.

In no event shall **Ross Video Limited** be liable for direct, indirect, special, incidental, or consequential damages (including loss of profits) incurred by the use of this product. Implied warranties are expressly limited to the duration of this warranty.

IN CASE OF PROBLEMS:

Should any problem arise with your **RossGear Terminal Equipment Product**, please contact our **Customer Service Department** at **613-652-4886**, 24 hours a day, 7 days a week.

A Return Material Authorization number (RMA) will be issued to you, as well as specific shipping instructions, should you wish our factory to repair your **RossGear** product. A temporary replacement, if required, will be made available for a nominal charge. Any shipping costs incurred, will be the responsibility of you, the customer. All products shipped to you from **Ross Video Limited**, will be shipped collect.

RossGear Terminal Equipment product advice is available, without charge, for the life of this equipment.