Ross Video Limited

**CDK-111A-Lite
Owner's Guide
Installation and Operation**

Software Issue 4

Live Production Technology™

CDK-111A-Lite Owner's Guide • Installation and Operation

- Ross Part Number: **1111DR-005**
- Document Issue: **4B**
- Printing Date: February 11, 2008. Printed in Canada.
- Software Version: **4**

The information contained in this guide is subject to change without notice or obligation.

Copyright

© 2008 Ross Video Limited. All rights reserved.

Contents of this publication may not be reproduced in any form without the written permission of Ross Video Limited. Reproduction or reverse engineering of copyrighted software is prohibited.

Notice

The material in this guide is furnished for informational use only. It is subject to change without notice and should not be construed as a commitment by Ross Video Limited. Ross Video Limited assumes no responsibility or liability for errors or inaccuracies that may appear in this manual.

Trademarks

-  is a registered trademark of Ross Video Limited.
- Ross, ROSS, ROSS®, and RossGear are registered trademarks of Ross Video Limited.
- All other product names and any registered and unregistered trademarks mentioned in this guide are used for identification purposes only and remain the exclusive property of their respective owners.

RossGear Terminal Equipment • Warranty and Repair Policy

This **RossGear** product is warranted to be free of any defect with respect to performance, quality, reliability, and workmanship for a period of **FIVE (5)** years from the date of shipment from our factory. In the event that your RossGear CDK-111A-M proves to be defective in any way during this warranty period, Ross Video Limited reserves the right to repair or replace this piece of equipment with a unit of equal or superior performance characteristics.

Should you find that this RossGear CDK-111A-M has failed after your warranty period has expired, we will repair your defective product for as long as suitable replacement components are available. You, the owner, will bear any labor and/or part costs incurred in the repair or refurbishment of said equipment beyond the FIVE (5) year warranty period.

In no event shall Ross Video Limited be liable for direct, indirect, special, incidental, or consequential damages (including loss of profits) incurred by the use of this product. Implied warranties are expressly limited to the duration of this warranty.

This RossGear CDK-111A-M Owner's Guide provides all pertinent information for the safe installation and operation of your RossGear CDK-111A-M. Ross Video policy dictates that all repairs to the CDK-111A-M are to be conducted only by an authorized Ross Video Limited factory representative. Therefore, any unauthorized attempt to repair this product, by anyone other than an authorized Ross Video Limited factory representative, will automatically void the warranty. Please contact Ross Video Technical Support for more information.

In Case of Problems

Should any problem arise with your CDK-111A-M, please contact the Ross Video Technical Support Department. (Contact information is supplied at the end of this publication.)

A Return Material Authorization number (RMA) will be issued to you, as well as specific shipping instructions, should you wish our factory to repair your CDK-111A-M. A temporary replacement module, if required, will be made available at a nominal charge. Any shipping costs incurred, will be the responsibility of you, the customer. All products shipped to you from Ross Video Limited, will be shipped collect.

The Ross Video Technical Support Department will continue to provide advice on any product manufactured by Ross Video Limited, beyond the warranty period without charge, for the life of this equipment.

Important Regulatory and Safety Notices

Before using this product and any associated equipment, refer to the “Important Safety Instructions” listed below so as to avoid personnel injury and to prevent product damage.

Products may require specific equipment, and /or installation procedures be carried out to satisfy certain regulatory compliance requirements. Notices have been included in this publication to call attention to these Specific requirements.

Symbol Meanings



This symbol on the equipment refers you to important operating and maintenance (servicing) instructions within the Product Manual Documentation. Failure to heed this information may present a major risk of damage or injury to persons or equipment.



Warning

The symbol with the word “**Warning**” within the equipment manual indicates a potentially hazardous situation, which if not avoided, could result in death or serious injury.



Caution

The symbol with the word “**Caution**” within the equipment manual indicates a potentially hazardous situation, which if not avoided, may result in minor or moderate injury. It may also be used to alert against unsafe practices.



Notice

The symbol with the word “**Notice**” within the equipment manual indicates a situation, which if not avoided, may result in major or minor equipment damage or a situation which could place the equipment in a non-compliant operating state.



**ESD
Susceptibility**

This symbol is used to alert the user that an electrical or electronic device or assembly is susceptible to damage from an ESD event.

Important Safety Instructions



Caution

This product is intended to be a component product of the RossGear 8000 series frame. Refer to the RossGear 8000 series frame User Manual for important safety instructions regarding the proper installation and safe operation of the frame as well as it’s component products.



Warning

Certain parts of this equipment namely the power supply area still present a safety hazard, with the power switch in the OFF position. To avoid electrical shock, disconnect all A/C power cords from the chassis’ rear appliance connectors before servicing this area.



Warning

Service barriers within this product are intended to protect the operator and service personnel from hazardous voltages. For continued safety, replace all barriers after any servicing.

This product contains safety critical parts, which if incorrectly replaced may present a risk of fire or electrical shock. Components contained within the product’s power supplies and power supply area, are not intended to be customer serviced and should be returned to the factory for repair.

To reduce the risk of fire, replacement fuses must be the same type and rating. Only use attachments/accessories specified by the manufacturer.

EMC Notices

US FCC Part 15

This equipment has been tested and found to comply with the limits for a class A Digital device, pursuant to part 15 of the FCC Rules. These limits are designed to provide reasonable protection against harmful interference when the equipment is operated in a commercial environment. This equipment generates, uses, and can radiate radio frequency energy and, if not installed and used in accordance with the instruction manual, may cause harmful interference to radio communications. Operation of this equipment in a residential area is likely to cause harmful interference in which case users will be required to correct the interference at their own expense.



Notice

Changes or modifications to this equipment not expressly approved by Ross Video Ltd. could void the user's authority to operate this equipment.

CANADA

This Class "A" digital apparatus complies with Canadian ICES-003.

Cet appareil numérique de classe "A" est conforme à la norme NMB-003 du Canada.

EUROPE

This equipment is in compliance with the essential requirements and other relevant provisions of **CE Directive 93/68/EEC**.

INTERNATIONAL

This equipment has been tested to **CISPR 22:1997** along with amendments **A1:2000** and **A2:2002** and found to comply with the limits for a Class A Digital device.



Notice

This is a Class A product. In domestic environments this product may cause radio interference in which case the user may have to take adequate measures.

Maintenance/User Serviceable Parts

Routine maintenance to this RossGear product is not required. This product contains no user serviceable parts. If the module does not appear to be working properly, please contact Technical Support using the numbers listed under the "Contact Us" section on the last page of this manual. All RossGear products are covered by a generous 5-year warranty and will be repaired without charge for materials or labor within this period. See the "Warranty and Repair Policy" section in this manual for details.

Company Address



Ross Video Limited
8 John Street
Iroquois, Ontario, K0E 1K0
Canada

Ross Video Incorporated
P.O. Box 880
Ogdensburg, New York
USA 13669-0880

General Business Office: (+1) 613 • 652 • 4886
Fax: (+1) 613 • 652 • 4425
Technical Support: (+1) 613 • 652 • 4886

E-mail (Technical Support): techsupport@rossvideo.com
E-mail (General Information): solutions@rossvideo.com
Website: <http://www.rossvideo.com/>
After Hours Emergency: (+1) 613 • 349 • 0006

Technical Support

At Ross Video, we take pride in the quality of our products, but if problems occur, help is as close as the nearest telephone.

Our 24-hour Hot Line service ensures you have access to technical expertise around the clock. After-sales service and technical support is provided directly by Ross personnel. During business hours (eastern standard time), technical support personnel are available by telephone any time. After hours and on weekends, a direct emergency technical support phone line is available. If the technical support personnel who is on call does not answer this line immediately, a voice message can be left and the call will be returned shortly. These people are available to react to any problem and to do whatever is necessary to ensure customer satisfaction.

For **Technical Support**, call (+1) 613-652-4886 and, for **After Hours Emergency**, dial (+1) 613-349-0006.

Environmental Information

The equipment that you purchased required the extraction and use of natural resources for its production. It may contain hazardous substances that could impact health and the environment.

To avoid the potential release of those substances into the environment and to diminish the need for the extraction of natural resources, Ross Video encourages you to use the appropriate take-back systems. These systems will reuse or recycle most of the materials from your end-of-life equipment in an environmentally friendly and health conscious manner.

The crossed-out wheeled bin symbol invites you to use these systems.

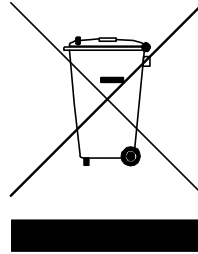

If you need more information on the collection, reuse, and recycling systems, please contact your local or regional waste administration.

You can also contact Ross Video for more information on the environmental performances of our products.

Contents

Introduction	1-1
A Word of Thanks	1-1
About This Guide	1-2
Documentation Conventions.....	1-3
Documentation Terms	1-4
Abbreviations.....	1-5
Overview	1-6
Product Comparison Chart.....	1-7
Feature Comparison Chart.....	1-7
CDK-111A-Lite Block Diagram.....	1-8
A Word about Technical Support	1-9
Installation and Setup	2-1
In This Chapter	2-1
Static Discharge.....	2-1
Getting Started.....	2-2
Unpacking	2-2
Overview	2-3
BNC Connectors.....	2-5
CDK-111A-Lite Connectors.....	2-5
CDK-111A-Lite BNC Settings.....	2-5
Connecting Video and Communication Cables	2-6
Video Input and Output Cable Connections.....	2-6
Communication Cables and Jumper Settings	2-6
Accessing the Menu System	2-9
Card Edge Controls	2-9
Navigating Through the Menus Using the Card Edge Buttons	2-10
Control Panel – DCP-111 (Optional)	2-11
Navigating Through the Menus Using the Control Panel.....	2-13
Card Setup and Configuration	2-14
Menu D: Card Setup.....	2-14
Card Address Configuration	2-17
Less Than 16 Cards	2-17
16 or More Cards.....	2-18
Operation	3-1
In This Chapter	3-1
Card Edge Controls.....	3-2
LED Functions.....	3-4
Control Panel – DCP-111 (Optional).....	3-5
DCP-111 Control Buttons	3-6
GPIs and Tallies.....	3-7

GPIs.....	3-7
Tallies.....	3-8
The Menu System.....	3-9
Menu Feature Descriptions.....	3-9
Menu Titles.....	3-10
Menu 1: Runtime Parameters.....	3-11
Menu 2: Key1 Setup.....	3-11
Menu 3: Reserved For Future Use.....	3-12
Menu 4: Box Mask Positioning.....	3-13
Menu 5: Matte Selection.....	3-13
Menu 6: Reserved For Future Use.....	3-13
Menu 7: Reserved For Future Use.....	3-13
Menu 8: Image Freezing, Storage, and Deletion.....	3-13
Menu 9: Input/Output Delays.....	3-14
Menu A: Diagnostics.....	3-15
Menu B: Reserved For Future Use.....	3-15
Menu C: Secondary Card Setup.....	3-16
Menu D: Card Setup.....	3-16
Menu E: Tally / GPI Setup.....	3-18
Menu F: BNC Listing.....	3-19

Appendix A. Serial Protocols **4-1**

In This Appendix.....	4-1
GVG 100 Emulation Protocol.....	4-2
General Description.....	4-2
Editor Transmission Standard.....	4-3
Editor Connector Pinouts.....	4-3
Protocol Elements.....	4-4
Break Character (00).....	4-5
Address Byte (Editor Select Address).....	4-5
Command/Message Block Structure.....	4-6
Byte Count Byte.....	4-7
Effects Address Byte.....	4-7
Command Code Byte (Read, Write).....	4-7
Message Bytes.....	4-9
Editor Interface State Diagram.....	4-10
Protocol Command Descriptions.....	4-11
List of Commands.....	4-11
Additions to the GVG 100 Emulation Protocol.....	4-24
Extra Commands / Control Numbers:.....	4-24
Commands Not Implemented.....	4-24
Other Differences.....	4-24
GVG MASTER2100 Emulation Protocol.....	4-25
Command Format.....	4-25
Command List.....	4-27
GVG MASTER2100 Emulation Commands.....	4-28

Appendix B. Software Upgrades **5-1**

In This Appendix.....	5-1
Software Upgrade.....	5-2
Replacing the CPU Boot Flash Chip.....	5-2

Appendix C. Specifications **6-1**

In This Appendix.....	6-1
-----------------------	-----

Technical Specifications	6-2
General	6-2
System Timing	6-2
Feature Comparison Chart.....	6-3
Analog Reference Input.....	6-3
Video Inputs	6-4
Video Outputs.....	6-4
CDK-111A-Lite BNC Connectors	6-4
CDK-111A-Lite BNC Settings.....	6-5
Baud Rates.....	6-6
Cable Assemblies	6-6
I/O, Power, Delay Specifications	6-7
GPI Inputs, Tally Outputs and Serial Communication	6-7
Jumper Locations	6-8
Jumper Pinouts	6-8
Jumper Configurations	6-8

Index

7-1

Introduction

A Word of Thanks

Congratulations on your purchase of the Ross Video CDK-111A-Lite Component Digital Keyer.

The CDK-111A-Lite is part of a full line of Ross Video digital products which are backed by over 25 years of engineering and design expertise.

You will be pleased at how easily your new CDK-111A-Lite fits into your overall working environment. Equally pleasing is the product quality, reliability, and functionality.

Once again, thank you for joining the ranks of satisfied Ross Video customers – throughout the world!

About This Guide

This guide covers the installation and operation of the Ross Video CDK-111A-Lite, Component Digital Keyer.

Along with a **Table of Contents**, the following chapters are included:

- Chapter 1, “**Introduction**” summarizes the guide and describes the components and features of the CDK-111A-Lite.
- Chapter 2, “**Installation and Setup**” provides basic installation instructions for each module, including cabling, jumper settings, and communication configuration.
- Chapter 3, “**Operation**” provides a detailed chart of all card-level functions, plus comprehensive information on all operating modes, menus, and features.
- Appendix A, “**Serial Protocol**” outlines the communication protocols used by the CDK-111A-Lite.
- Appendix B, “**Software Upgrades**” provides detailed instructions on how to perform software upgrades.
- Appendix C, “**Specifications**” outlines the module specifications.

An **Index** is also provided for your reference.

Should you have a question pertaining to the operation of your CDK-111A-Lite, please contact us at the numbers listed in the front of this guide. Our technical support staff is always available for consultation, training, or service.

Documentation Conventions

The following conventions are used throughout this guide:

- Rear panel connectors and card-level components are indicated in bold-faced upper case letters. For example:

The **NTSC/PAL OUT 1** connector is ...

- Menu functions on the Preview Overlay are indicated in bold-faced upper and lower case text. For example:

The **NTSC Setup Function** allows you to ...

- Menu choices on the Preview Overlay are indicated in bold-faced upper case letters, using sans-serif font. For example:

Select **BANK A** to access the first bank of ...

Documentation Terms

The following terms are used throughout this guide:

- “**Chassis**” and “**Frame**” both refer to the DFR-8014A-C and DFR-8110A-C frames that house the CDK-111A-Lite modules.
- “**Operator**” and “**User**” both refer to the person who uses the CDK-111A-Lite.
- “**Board**”, “**Card**”, and “**Module**” all refer to the CDK-111A-Lite card itself, including all components and switches.
- “**SDI**”, **Serial Digital Interface**, **CCIR-601**, all refer to the serial digital video signal that is distributed via a single coaxial cable with BNC connectors and is used by the CDK-111A-Lite.
- “**System**” and “**Video System**” refers to the mix of interconnected digital and analog production equipment in which the CDK-111A-Lite operates.

Abbreviations

The following abbreviations are used throughout this guide:

Abbreviation Guide

Abbreviation	Definition
A-D	Analog-to-Digital
BKGD	Background Bus
D-A	Digital-to-Analog
DA	Distribution Amplifier
DSK	Downstream Keyer
DVE	Digital Video Effects
EDH	Error Detection and Handling
GPI	General Purpose Interface
ID	Identification
PGM	Program
PV	Preview
RU	Rack Unit
SDI	Serial Digital Interface

Overview

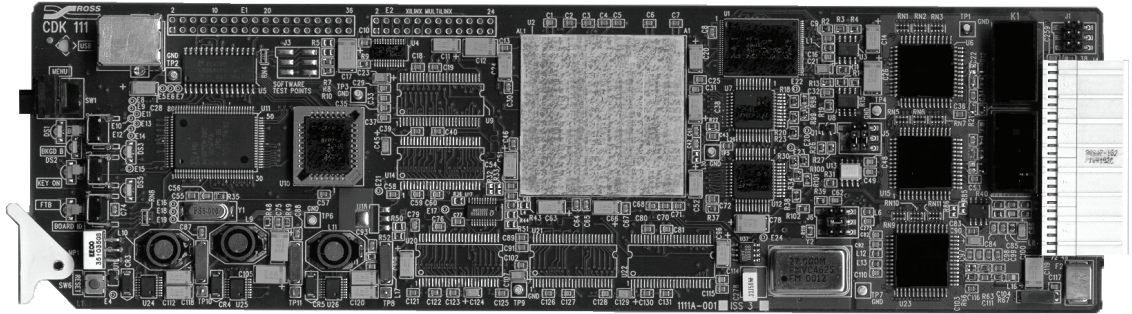

CDK-111A-Lite Card

The CDK-111A-Lite is the most advanced single card component digital keyer available on the market today. It suits a multitude of situations where high quality digital video keying and mixing is performed. With built-in fade-to-black and fail-safe relay design, CDK-111A-Lites are the perfect device for your critical program stream applications.

All CDK-111A-Lite input video signals can be referenced to the BKGD 1 input. All signals can have full frame synchronization capability with infinite timing adjustment. This makes it easy to install and eliminates many system timing issues.

Control over the CDK-111A-Lite is available via GPI, RS-422 unbalanced full duplex RS-485 or 0-12V RS-232 compatible, on-screen menu, remote control panel, and card-edge pushbuttons for unsurpassed flexibility. As well, configurable on-air tally outputs are also available.

Also, the cards are fully compatible with Ross Video's DFR-8110A-C (2 RU) and DFR-8104A-C (1 RU) frames.

Product Comparison Chart

For your reference, the following is a detailed chart that compares the features that are available with the CDK-111A-Lite and the CDK-111A-M card configurations. For further information on the CDK-111A-M, see the *CDK-111A-M Owner's Guide, v4*.

Feature Comparison Chart

Feature	CDK-111A-Lite	CDK-111A-M
Video input channels	3	4
Number of keys on air	1	2
Preview Overlay menu display	No	Yes
BKGD crossfade	No	Yes
Frame synchronization on every input	Yes	Yes
External analog reference signal input	Yes	Yes
Adjustable delay from reference to output signal	Yes	Yes
Storage for multiple stills and animated logos	No	32MB
Fade to black	Yes	Yes
Program output with EDH insertion	Yes	Yes
Second program output with EDH insertion	Yes	Yes (1)
One preview output with EDH insertion	No	Yes (1)
Fail-safe relay BKGD1 to PGM Out 1 on power failure	Yes	Yes
Accommodates SMPTE 259M-C	Yes	Yes
USB port for image download	No	Yes
Full transition control with 0-999 frame control	Yes	Yes
Clip, gain, matte fill, and box mask controls	Yes	Yes
Control via GPI, unbalanced full duplex RS-485 or 0-12V RS-232 compatible interface, on-screen configuration menu, control panel, and card-edge pushbuttons	Yes	Yes
Supports 525-line (NTSC) and 625-line (PAL) formats	Yes	Yes
Serial interface	Yes	Yes
5 year warranty	Yes	Yes

1) Configured via the menu, if desired

CDK-111A-Lite Block Diagram

The CDK-111A-Lite is a single card broadcast quality digital keyer designed specifically for broadcast or production situations.

The figure below illustrates a block diagram of the CDK-111A-Lite:

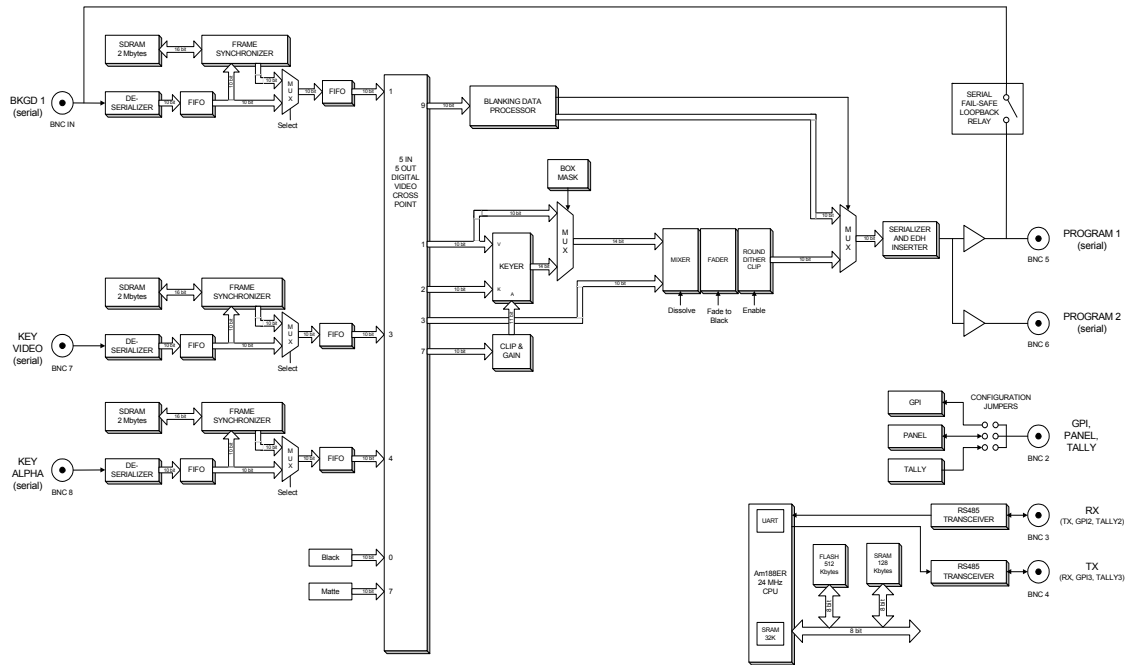

CDK-111A-Lite Block Diagram

The CDK-111A-Lite is housed in a RossGear **DFR-8110A-C** or **DFR-8104A-C** frame.

The BNC connector configuration at the rear of the frame is shown below:

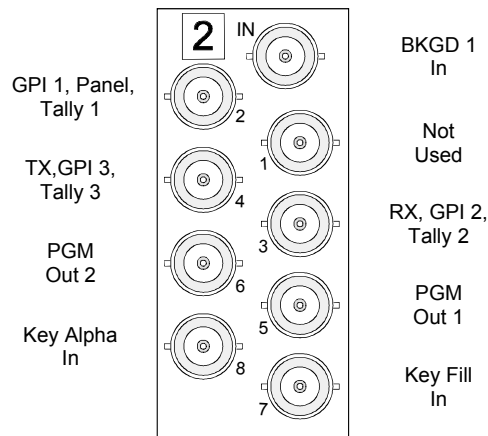

CDK-111A-Lite BNC Connectors

A Word about Technical Support

At Ross Video, we take pride in the quality of our products, but if problems occur, help is as close as the nearest telephone.

Our 24-hour Hot Line service ensures you have access to technical expertise around the clock. After-sales service and technical support is provided directly by Ross personnel. During business hours (eastern standard time), technical support personnel are available by telephone any time. After hours and on weekends, a direct emergency technical support phone line is available. If the technical support personnel who is on call does not answer this line immediately, a voice message can be left and the call will be returned shortly. These people are available to react to any problem and to do whatever is necessary to ensure customer satisfaction.

For **Technical Support**, call (+1) 613-652-4886 and, for **After Hours Emergency**, dial (+1) 613-349-0006.

Installation and Setup

In This Chapter

This chapter provides instructions for the installation and setup of your CDK-111A-Lite. The following topics are discussed:

- Getting Started
- Overview
- BNC Connectors
- Connecting the Cables
- Accessing the Menu System
- Card Edge Controls
- Control Panel
- Card Setup and Configuration
- Card Address Configuration

Static Discharge

Throughout this chapter, please heed the following cautionary note:



Static discharge can cause serious damage to sensitive semiconductor devices. Avoid handling the CDK-111A-Lite cards in high static environments such as carpeted areas and when synthetic fiber clothing is worn. Touch the rack frame to dissipate static charge before removing cards from the frame and exercise proper grounding precautions when working on the CDK-111A-Lite cards.

Getting Started

Unpacking

Unpacking your CDK-111A-Lite shipment will be unique for each customer and will depend upon your specific order. However, the following general rules will apply:

- If your order includes either RossGear **DFR-8110A-C** or **DFR-8014A-C** frames, your CDK-111A-Lites will be shipped to you already installed in the frames.

Note

Please ensure that each card is properly seated before turning on the power.
--

- If your order does not include any rack frames, the cards will be shipped to you in a 10-pack RossGear Terminal Equipment Pack box.

Once the rack frames and/or boxes are unpacked, check the contents against the packing list to ensure that all items are included. If any items are missing or damaged, contact your sales representative or Ross Video Limited immediately.

Overview

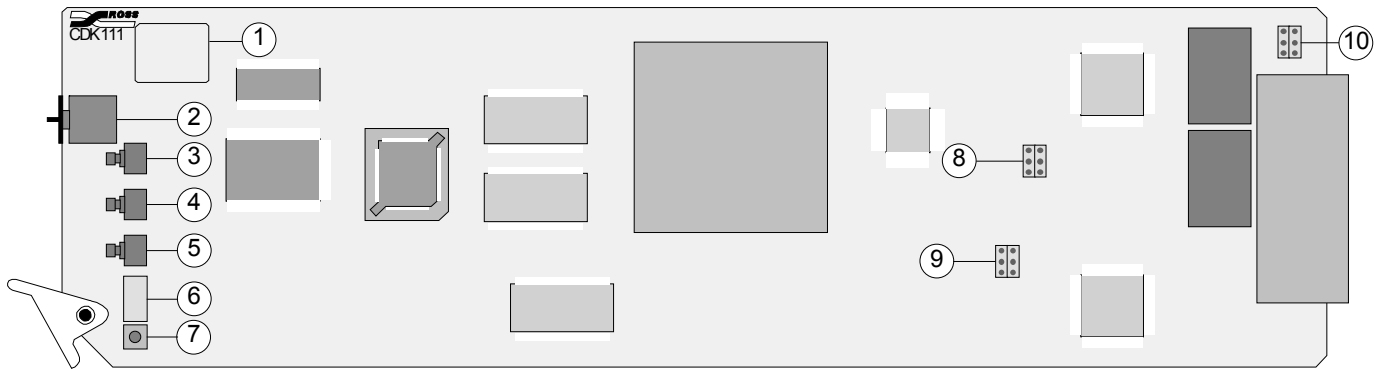

CDK111A-Lite Card, Component Side

1) USB Port (Not Implemented)	5) Menu Select / FTB Button	9) GPI, Panel, Tally Jumper Block
2) Menu Selector	6) Board ID Switch	10) RX Termination Jumper Block and Download Connector
3) Menu Up Button	7) Reset Button	
4) Menu Down / Key Button	8) EDH Insertion Jumper Block	

1) USB Port (J2)

Not implemented.

2) Menu Selector (SW1)

The Menu Selector is a 16 position rotary knob, labeled **0** to **F**. It is used to select the various menus for card installation and operation.

3) Menu Up Button (SW2)

Menu mode – this button moves the cursor to the item above on the menu. A momentary press will advance one item. When an item is selected, holding the button will scroll up through the possible values.

4) Menu Down / Key Button (SW3)

Operation mode – this button will dissolve a key on or off. It uses the transition rate set in the menu.

Menu mode – this button moves the cursor to the item below on the menu. A momentary press will advance one item. When an item is selected, holding the button will scroll up through the possible values.

5) Menu Select / FTB Button (SW4)

Operation mode – this button fades the PGM output to black or brings the PGM up from black, depending upon its present state. It uses the transition rate set in the menu.

Menu mode – this button moves the cursor to the sub-menu values in the right-hand column. The values in these sub-items can then be adjusted using the **Menu Up** or **Menu Down** button. Pressing the **Menu Select** button again will return the cursor to the left-hand column.

6) **Board ID Switch (SW5)**

The **Board ID** Switch is a 16 position rotary knob, labeled **0** to **F**. In a multiple card setup, it is used to define the card's unique address for communication purposes.

7) **Reset Button (SW6)**

Pressing the Reset Button will reset the card to a power-up state with BKGD 1 on-air with no key.

8) **EDH Insertion Jumper Block (J5)**

The jumper block is used to insert the EDH information into the PGM video stream. See Appendix C, “**Specifications**” for jumper pinout reference.

9) **GPI, Panel, Tally Jumper Block (J6)**

This jumper block is used in conjunction with the menu (software) to define the status of BNC 2 – whether it is used as an input for a GPI, an input/output for a Control Panel, or as a Tally output. See Appendix C, “**Specifications**” for jumper pinout reference.

10) **RX Termination Jumper Block (J1)**

If BNC 3 and 4 are used as Rx input and Tx output connectors, this jumper block is used to terminate BNC 3 and 4. See Appendix C, “**Specifications**” for jumper pinout reference.

BNC Connectors

This section defines the BNC connector assignments for the CDK-111A-Lite card:

CDK-111A-Lite Connectors

The CDK-111A-Lite has nine (9) BNC connectors on the rear of each module, as shown below:

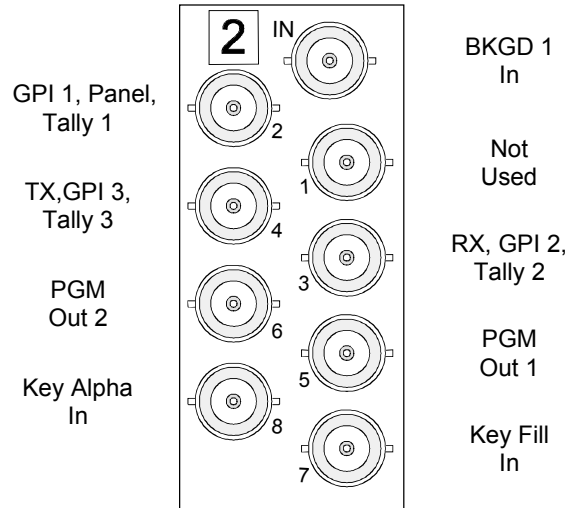

CDK-111A-Lite Connector Assignments

CDK-111A-Lite BNC Settings

Connector	Use
IN	BKGD 1 In – any video source, used as card reference
1	Not Used
2	GPI 1 or Panel or Tally 1 – (configurable via menu and jumper setting)
3	RX or GPI 2 or Tally 2 – (configurable via menu)
4	TX or GPI 3 or Tally 3 – (configurable via menu)
5	PGM Out 1
6	PGM Out 2
7	Key Fill In
8	Key Alpha In

Connecting Video and Communication Cables

Video Input and Output Cable Connections

Connect the appropriate input video sources as shown in the above tables and diagrams to the BNC connectors on the rear of the CDK-111A-Lite, using up to 75 meters of industry standard 75 Ohm coaxial cable and BNC connectors.

Connect the output video connections as appropriate for your facility.

Note

All inputs and outputs are SMPTE 259M-C (SDI) digital video signals. D–A converters may be required for some devices (e.g., monitors, VTRs, etc.).

For more information on our complete line of converters and distribution equipment, contact your Ross Video dealer or visit our website at www.rossvideo.com.

Communication Cables and Jumper Settings

If the operational requirements of your facility require you to communicate with your CDK-111A-Lite via the Rx (BNC 3) and Tx (BNC 4) serial ports, use the following diagrams to connect the appropriate cables and set the appropriate jumpers.

Single CDK-111A-Lite Settings for RS 422/485 Communication

A single CDK-111A-Lite connects to an RS 422/485 serial device via the Serial Interface Cable (supplied with CDK-111A-Lite, P/N 1111C-301), which splits the Rx and Tx signals.

The interface cable is approximately 2 ft. in length and has a Type “D”, 9-pin connector on one end and 2 coaxial cables with female BNC connectors on the other. Extend the communication cables to the required length for your facility (up to 300 meters) using 75 Ohm coaxial cables and BNC connectors.

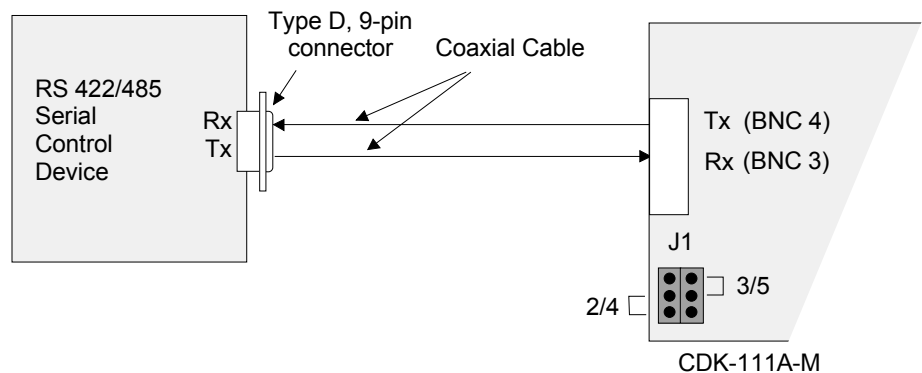

Single CDK-111A-Lite RS 422/485 Cabling and Jumper Settings

Note

When a single CDK-111A-Lite is connected via the serial ports, the card *must* be terminated. Bridge pins 2 and 4, and pins 3 and 5 on jumper **J1** to terminate the card. See Appendix C, “**Specifications**” and the silk screen on the back of the card for jumper pinout reference.

Single CDK-111A-Lite Settings for RS 232 Communication

A single CDK-111A-Lite connects to an RS 232 serial device via the Serial Interface Cable (supplied with CDK-111A-Lite, P/N 1111C-301), which splits the Rx and Tx signals.

The interface cable is approximately 2 ft. in length and has a Type “D”, 9-pin connector on one end and 2 coaxial cables with female BNC connectors on the other. Extend the communication cables to the required length for your facility (up to 300 meters) using 75 Ohm coaxial cables and BNC connectors.

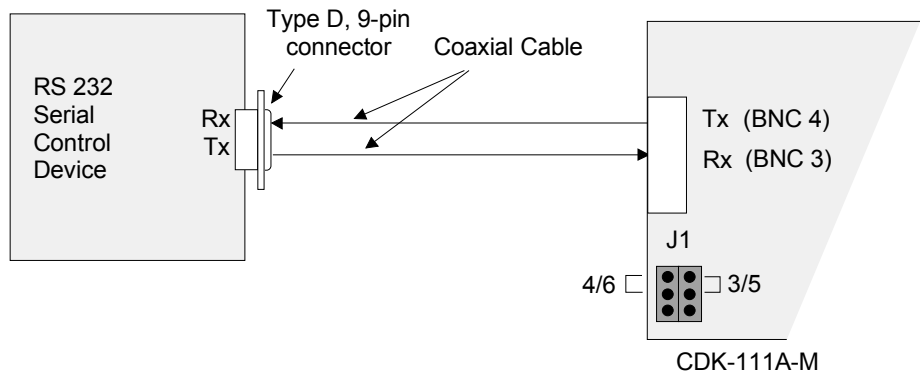

Single CDK-111A-Lite RS 232 Cabling and Jumper Settings

Multiple CDK-111A-Lite Settings for RS 485 Communication

Up to 127 CDK-111A-Lites can be daisy-chained from a single RS 485 serial device using industry standard, 75 Ohm coaxial cable. The initial connection to the serial port is made with the Serial Interface Cable (supplied with CDK-111A-Lite, P/N 1111C-301), which splits the Rx and Tx signals. The individual cables are then split at each card using a BNC “T” connector and connected to either BNC 3 or BNC 4, as shown in the figure on page 2-8.

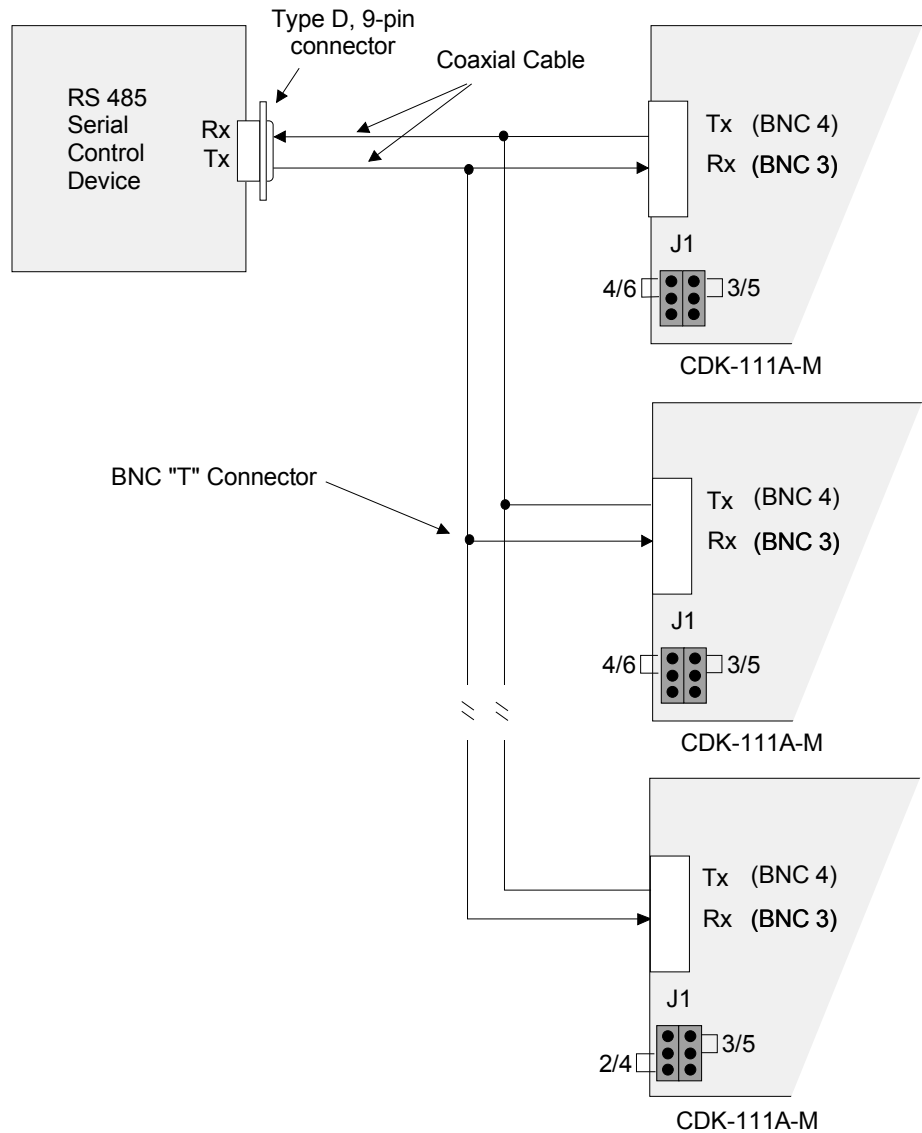

Multiple CDK-111A-Lites Communication Cable Connections

Note

When multiple CDK-111A-Lites are connected to a serial port, the last card in the series *must* be terminated. Bridge pins 2 and 4, and pins 3 and 5 on jumper **J1** to terminate the last card.

On all other cards, place a jumper on pins 4 and 6 and one on pins 3 and 5. See Appendix C, “**Specifications**” and the silk screen on the back of the card for jumper pinout reference.

If your facility requires more than 127 CDK-111A-Lites, a second serial port must be used to control the next 127 cards.

The interface cables are approximately 2 ft. in length and have a Type “D”, 9-pin connector on one end and two coaxial cables with male BNC connectors on the other. Extend the communication cables to the required length for your facility (up to 300 meters) using 75 Ohm coaxial cables and BNC connectors.

Accessing the Menu System

Setup and configuration of your CDK-111A-Lite is done through a menu system that is accessed in one of two ways – via the button and knob controls on the card edge or the optional Digital Mixer Keyer Control Panel.

Card Edge Controls

There is a knob and three card edge buttons used to access the menu system, as in the diagram below. For a description of how each is used, please refer to the previous section titled **Overview**.

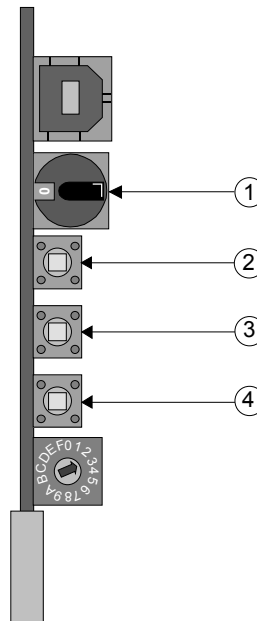

Card Edge Controls

- | | |
|--------------------------|-----------------------------|
| 1) Menu Selector | 3) Menu Down / Key Button |
| 2) Menu Up / BKGD Button | 4) Menu Select / FTB Button |

Navigating Through the Menus Using the Card Edge Buttons

Enter the menus by turning the Menu Selector (1) knob. The Menu Selector is a 16 position rotary knob, labeled **0** through **F** (hex). Position **0** is the operational state. Rotating the selector through positions **1** to **F** will display the 15 different menus as a preview overlay on the PGM monitor as per the example below:



Example of the Menu Preview Overlay – Menu 1: Runtime Parameters

Each menu has a number or letter in the upper left hand corner, which corresponds to the label on the selector knob, along with its title.

Most menus are shown as two columns. The left hand column contains a list of parameters for that specific menu, while the right hand column contains values, Boolean choices or lists associated with an item.

Once you have chosen a menu, use the Menu Up (2) and Menu Down (3) buttons to move the cursor and navigate through the items on each menu. Pressing the Menu Up button will move the cursor on the left hand side of the menu to the item above. Likewise, pressing the Menu Down button will move the cursor to the next item below on the list. Some items have a single Menu Help line at the bottom of the menu, which gives additional detail for that item.

When you wish to select an item and change its value, press the Menu Select (4) button. The cursor will move to the right hand column. This column contains the values associated with each parameter and can be changed. A momentary press of the up or down button will either increase or decrease the value of that item. Holding either button down will cause the cursor to scroll through the values faster, thus saving setup time.

When you have set the value of an item, press the select button once again and the system will accept the new value and the cursor will return to its left hand position. When you have completed your setup, turn the Menu Selector knob back to **0**. The message, “**STORING DATA TO FLASH . . .**” will appear. When all of the changed values have been stored, the preview overlay and menu will disappear, and the card will be in its operational mode.

Control Panel – DCP-111 (Optional)

Use the Control Panel to configure and operate a single CDK-111A-Lite. The Control Panel can perform the same functions as the card edge controls.

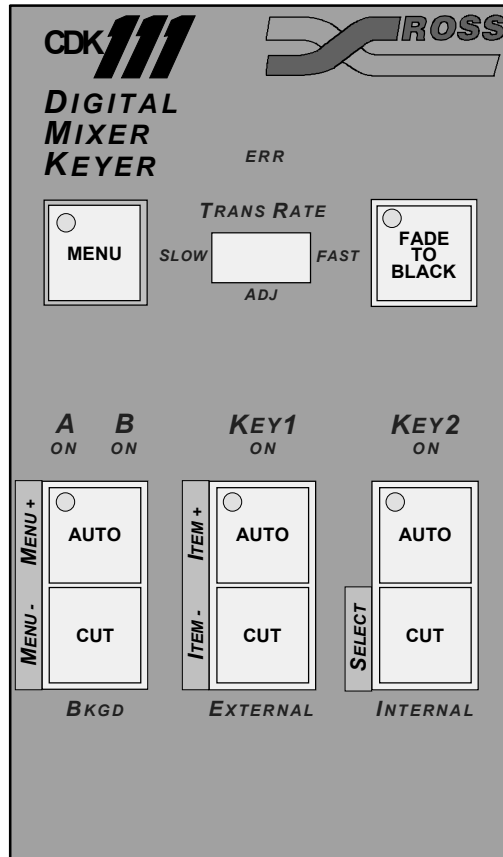

Digital Mixer Keyer Control Panel

DCP-111 Installation

Use the following steps to install and configure the card for use with the Control Panel.

1. Remove the card from the frame, if it is already installed.
2. On the card, bridge pins 3 and 4 of the **GPI, Panel, Tally Jumper Block (J6)**.



Note

Caution — Only one bridge may be installed on the jumper block **J6**. Installing more than one bridge may cause permanent damage to the CDK-111A-Lite card. Please note that contrary to the other jumper blocks, the single bridge on **J6** must be installed horizontally across either pins 1 and 2, or pins 3 and 4, or pins 5 and 6.

See item 9 in the **Overview** section of this chapter for jumper block location information.

See also Appendix C, “**Specifications**” and silk screening on the back of the card as jumper reference.

3. Re-install the card in the frame.
4. With the card active in the frame, set the card edge **Menu Selector** knob to **D**.
5. In the **Menu D: Card Setup** menu, navigate to the **BNC 2** menu item by pressing the **Menu Up** or **Menu Down** buttons on the card edge.
6. Move to the **BNC 2** submenu by pressing the **Menu Select** button.
7. Navigate to the **Control Panel** submenu item by pressing the **Menu Up** or **Menu Down** buttons.
8. To save the changed menu item value, press the **Menu Select** button once.
9. To store the changes, turn the **Menu Selector** knob back to **0**.

The message, “**STORING DATA TO FLASH . . .**” will appear. When all of the changed values have been stored, the menu will disappear from the screen, and the card will be in *Operation* mode.

10. Using up to 100 meters of industry standard 75 Ohm coaxial cable, connect the control panel cable to BNC 2 on the rear of the frame slot housing the CDK-111A-Lite.

Note

See Chapter 3, “ Operation ” for a complete description of the Control Panel.
--

Navigating Through the Menus Using the Control Panel

Enter the menus by pressing and holding the **MENU** button until the light in the upper left hand corner of the button flashes. This will take approximately 3 seconds. There are 15 menus in all, labeled **1** to **F** (hex). Once in the menu system, the buttons on the control panel take on a different meaning than their primary labels would indicate. (See Chapter 3, “**Operation**”, for a complete description of the Control Panel in its operational mode.)

You can scroll through the menus either forward or backward. In the **BKGD A / B** area, pressing the **MENU+** button will scroll forward through the menus, while pressing the **MENU-** button will scroll backward. The menu will be displayed as a preview overlay on the PGM monitor, as per the example below:

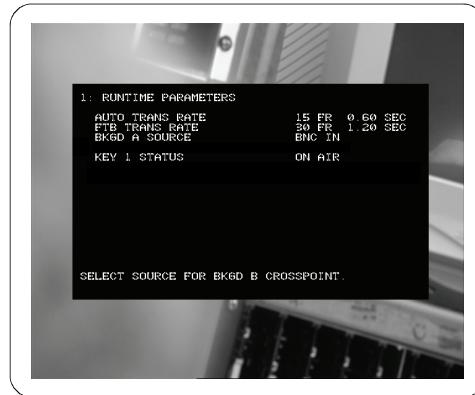

Example of the Menu Preview Overlay – Menu 1: Runtime Parameters

Each menu has a number and title displayed in the upper left hand corner.

Most menus are shown as two columns. The left hand column contains a list of items (or parameters) for that specific menu, while the right hand column contains values, Boolean choices or lists associated with each item.

Once you have chosen a menu, use the two **KEY1** buttons to move the cursor and navigate through the items on each menu. Pressing the **ITEM+** button will move the cursor on the left hand column to the **NEXT** item. Likewise, pressing the **ITEM-** button will move the cursor to the **PREVIOUS** item on the list. Some items have a single *Menu Help Line* at the bottom of the menu, which gives additional detail for that item.

When you wish to select an item and change its value, press the **KEY2** button labeled **SELECT**. The cursor will move to the right hand column. This column contains the values associated with each item. Momentarily pressing the **ITEM+** button will scroll forward through the variables, while pressing the **ITEM-** button will scroll backward through the variables. Holding either button down will cause the cursor to scroll through the values faster, thus saving setup time.

When you have set the value of an item, press the **SELECT** button once again and the system will accept the new value and the cursor will return to its left hand position.

When you have completed your setup, exit the menu system by pressing the **MENU** button again. The message, “**STORING DATA TO FLASH . . .**” will appear. When all of the changed values have been stored, the preview overlay and menu will disappear, and the card will be in *Operation* mode.

Card Setup and Configuration

Configuring the CDK-111A-Lite is done in the menus. Enter the menus (as described in above sections) and navigate to **Menu D: Card Setup**.

Note

See Chapter 3, “**Operation**” for details on **Menu D** items and their parameters.

Menu D: Card Setup

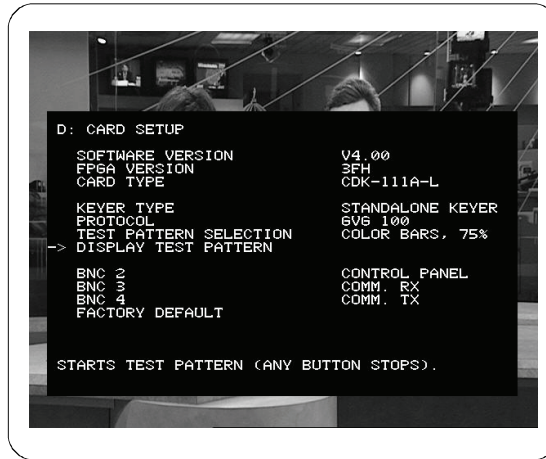

Menu D: Card Setup

The **Card Setup** menu allows you to configure the initial parameters of the CDK-111A-Lite and must be completed for each card.

The first three items in the menu are for informational purposes only.

- **Software Version**
The value on the right contains the version number of software loaded on this card. It is for information only and cannot be changed.
- **FPGA Version**
The value on the right contains the version number of the FPGA. It is for information only and can not be changed.
- **Card Type**
The card type will indicate a CDK-111A-Lite.

The next series allow you to configure your CDK-111A-Lite to meet your operational requirements.

- **Keyer Type**
Standalone Keyer.
- **Protocol**
There are three choices – None, Master 2100, and GVG 100.
- **Menu Output**
The Menu Output will display on the Program monitor.
- **Test Pattern Selection**
Select one of the built-in test patterns – Color bars 75%, EQ Pathological, PLL Pathological, Flat Field Black.
- **Display Test Pattern**
Pressing the Menu Select Button will display the test pattern that is presently selected.

The final items in **Menu D** allow you to define how you want your CDK-111A-Lite to operate and communicate with the rest of your facility. There are several variations to consider:

- **BNC 2**
BNC 2 can be configured in one of three ways – either as an input for a GPI, as the Control Panel connection point, or as a Tally output. To configure BNC 2 as a,
 - **GPI Input**
 - ~ Bridge jumper **J6** (see card diagram at the beginning of this chapter for the location of **J6**) at pins 1 and 2. See Appendix C, “**Specifications**” for jumper pinout reference.
 - ~ Set BNC 2 value in the menu to GPI #1.
 - **Control Panel Connection Point**
 - ~ Bridge jumper **J6** (see card diagram at the beginning of this chapter for the location of **J6**) on the card at pins 3 and 4.
 - ~ Set BNC 2 value in the menu to DCP.
 - **Tally Output**
 - ~ Bridge jumper **J6** (see card diagram at the beginning of this chapter for the location of **J6**) on the card at pins 5 and 6.
 - ~ Set BNC 2 value in the menu to Tally #1.

- **BNC 3**

BNC 3 can be configured in one of three ways – either as an RX input, a GPI input, or as a Tally output. To configure BNC 3 as an,

- **RX Input**

~ Set BNC 3 value in the menu to Comm. RX.

- **GPI Input**

~ Set BNC 3 value in the menu to GPI #2.

- **Tally Output**

~ Set BNC 3 value in the menu to Tally #2.

Note

If BNC 3 is configured as an RX input, ensure that BNC 4 is set to the corresponding TX configuration.
--

- **BNC 4**

BNC 4 can be configured in one of three ways – either as a TX output, a GPI input, or as a Tally output. To configure BNC 4 as a,

- **TX Output**

~ Set BNC 4 value in the menu to Comm. TX.

- **GPI Input**

~ Set BNC 4 value in the menu to GPI #3.

- **Tally Output**

~ Set BNC 4 value in the menu to Tally #3.

- **Factory Default**

Selecting the Factory Default will reset all values in all menus to the initial factory default settings.

When you have completed the initial setup for each card, the next step is to configure the unique address for each card in a multiple card setup.

If your facility has a single card, you can exit the menu system. If your video connections have been properly made and you are feeding video to the card, you should now see video on your PGM monitor. If you do not see video, double check your video cables, jumper settings and menu setup to determine where the problem lies.

Card Address Configuration

Once the BNCs, GPIs, tallies, and jumpers have been configured, the next step in a multiple CDK-111A-Lite card setup is to assign each card a unique address. This address is used by the control device to identify and communicate with a particular card.

There are two ways to set addresses -

- using the Board ID Switch in facilities with less than 16 cards
- through the menu system for facilities that have 16 or more cards.

Less Than 16 Cards

For facilities that have less than 16 cards, you can use the menu system (as described in the next section) or use the Board ID Switch on the bottom of the card edge to set the address of each card. See diagram below.

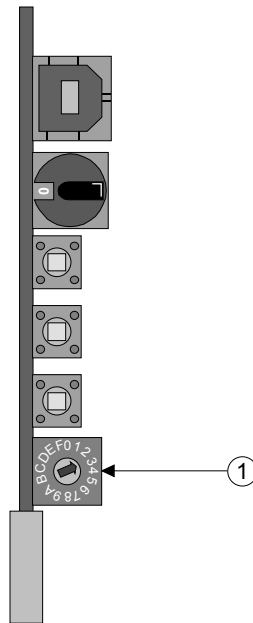

1) Board ID Switch

The **Board ID Switch** is a 16 position rotary knob labeled **0** through **F**.

Using a “tweaker” screwdriver, systematically set each card in the system to a different number on the **Board ID Switch**, using numbers **1** through **F**. Zero (**0**) is *not* a valid address for the first card.

See Appendix A, “**Serial Protocols**” for a complete explanation of the address system.

16 or More Cards

For facilities that have 16 or more cards, the menu system must be used to assign a unique address for each card. This address is used by the serial device to communicate with an individual card.

To set the card address (16-127 cards):

1. Set the Board ID Switch on each card to **0** before assigning any addresses with the menu.
2. Using the **Menu Selector** knob on the card edge, navigate to **Menu C: Secondary Card Setup**.

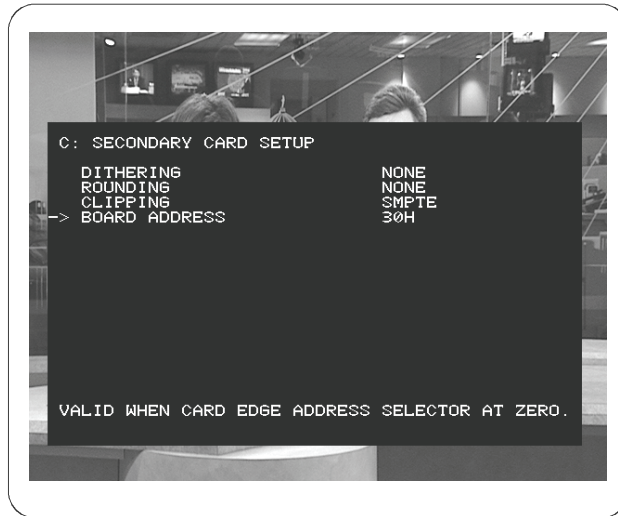

Menu C: Secondary Card Setup

Note

See Chapter 3, “**Operation**” for details on **Menu C** items and their parameters.

3. For each card, navigate to the **Board Addr** item and press the **Menu Select** button on the card edge to move the cursor to the menu item’s submenu column.

Note

The Board Addresses are displayed in hexadecimal and range from 0 (Hex) to FC (Hex). Addresses must be *even* numbers (a system requirement), and, therefore, the system is limited to a total of 127 uniquely numbered cards.

This is also the total number of cards that can be controlled from a single serial port.

For those not familiar with working in hexadecimal, the *even* digits are those that end in 0, 2, 4, 6, 8, A, C, and E.

4. Systematically enter the **Board Addr** item in each card and set its address to a unique *even* number.
5. When you have set a card’s address, press the **Menu Select** button again to return you to the left hand column.
6. Rotate the Menu Selector knob to the **0** position to save the data and exit the menu system.

This concludes the installation and setup section for your CDK-111A-Lite.

Operation

In This Chapter

This chapter describes in detail the function of all card edge buttons and knobs, control panel buttons, and the internal menus used during the operation of the CDK-111A-Lite.

Specifically, the following topics are discussed:

- Card Edge Controls
- LED functions
- Control Panel – DCP-111 (Optional)
- GPIs and Tallies
- The Menu System
- The Menus

Card Edge Controls

In Chapter 2, “**Installation and Setup**”, the card edge buttons and knobs were discussed in terms of installing and setting up your CDK-111A-Lite (*menu mode*). These same buttons and knobs perform a different role during operation (*operation mode*).

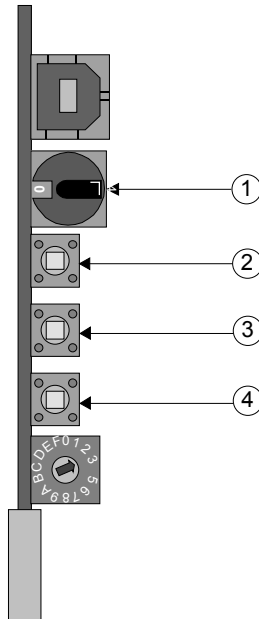

1)	Down / Key Button	Menu Selector	3)	Menu
2)	Select / FTB Button	Menu Up / Button	4)	Menu

1) Menu Selector (SW1)

The Menu Selector is a 16 position rotary knob, labeled **0** to **F**. It is used to select the various menus for card installation and operation.

It must be in position **0** during operation as a standalone keyer.

2) Menu Up/ (SW2)

- **Menu mode** – this Button is used to move the cursor to the item above on the menu. A momentary press will advance one item. When in a sub-menu, holding the button will cause the cursor to automatically scroll up through the items.

3) Menu Down/Key Button (SW3)

- **Operation mode** – pressing the Menu Down / Key Button will dissolve a key on or off, using the transition rate set in the menu.
- **Menu mode** – the Menu Down / Key Button is used to move the cursor to the item below on the menu. A momentary press will advance one item. When in a sub-menu, holding the button will cause the cursor to automatically scroll down through the items.

4) **Menu Select/FTB Button (SW4)**

- **Operation mode** – pressing the Menu Select / FTB Button will fade the PGM output to black or bring it up from black, depending upon its present state. It uses the transition rate set in the menu.
- **Menu mode** – the Menu Select / FTB Button is used to move the cursor to the sub-menu values in the right-hand column. The values in these sub-items can then be adjusted using the Menu Up or Down Button. Pressing the Menu Select Button again will return the cursor to the left-hand column.

LED Functions

Light Emitting Diodes (LEDs) on the CDK-111A-Lite cards indicate normal and error conditions. This section describes LED locations and functionality.

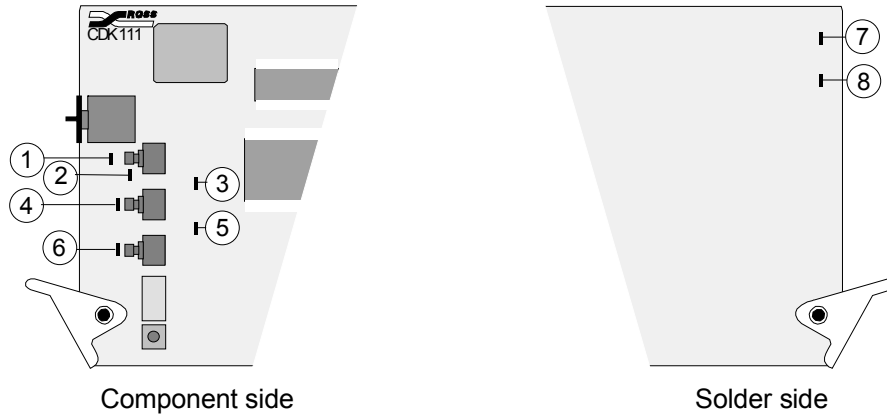

CDK-111A-Lite LED locations

1) DS1 BKGD 1	5) DS5 Status In
2) DS2 BKGD 2	6) DS6 FTB
3) DS3 Status Out	7) DS7 Signal Good
4) DS4 Key	8) DS8 Error

LED Functions and Indicators

LED	Signal for:	Color	Action	Status
DS1	BKGD 1	Green	Solid Flashing	On air Comm problem — video input sync error
DS2	BKGD 2	Green	Solid Flashing	Not Implemented Not Implemented
DS3	Status Out	Red	Flashing Slow Flashing Fast	Downloading/Drawing Comm problem — key video input sync error
DS4	Key	Green	Solid	On air
DS5	Status In	Red	Flashing Slow Flashing Fast	Downloading/Drawing Comm problem — key alpha input sync error
DS6	Fade to Black	Red	Solid	Faded To Black
DS7	Signal Good	Green	Solid Flashing Slow Flashing Fast	Signal Good Signal Good, Pinging other devices Comm problem — any input sync error
DS8	Error	Red	Solid Flashing Slow	Signal Error — Once error descriptions have been viewed in Menu A: Diagnostics, this light will turn off Attempting synchronization with ref input

Control Panel – DCP-111 (Optional)

The optional Control Panel is used to configure and/or operate a single CDK-111A-Lite. It is connected to BNC 2 on the rear of the CDK-111A-Lite. The Control Panel replicates the capabilities and functionality of the card edge controls.

Note

When using a Control Panel, ensure that the **GPI, Panel, Tally Jumper (J6)** is bridged at pins 3 and 4 on the jumper and BNC 2 is set in **Menu D: Card Setup** to Control Panel. See Appendix C, “**Specifications**” and the silk screening on the back of the CDK-111A-Lite card for jumper setting reference.



Caution — Only one bridge may be installed on the jumper block **J6**. Installing more than one bridge may cause permanent damage to the CDK-111A-Lite card. Please note that contrary to the other jumper blocks, the single bridge on **J6** must be installed horizontally across either pins 1 and 2, or pins 3 and 4, or pins 5 and 6.

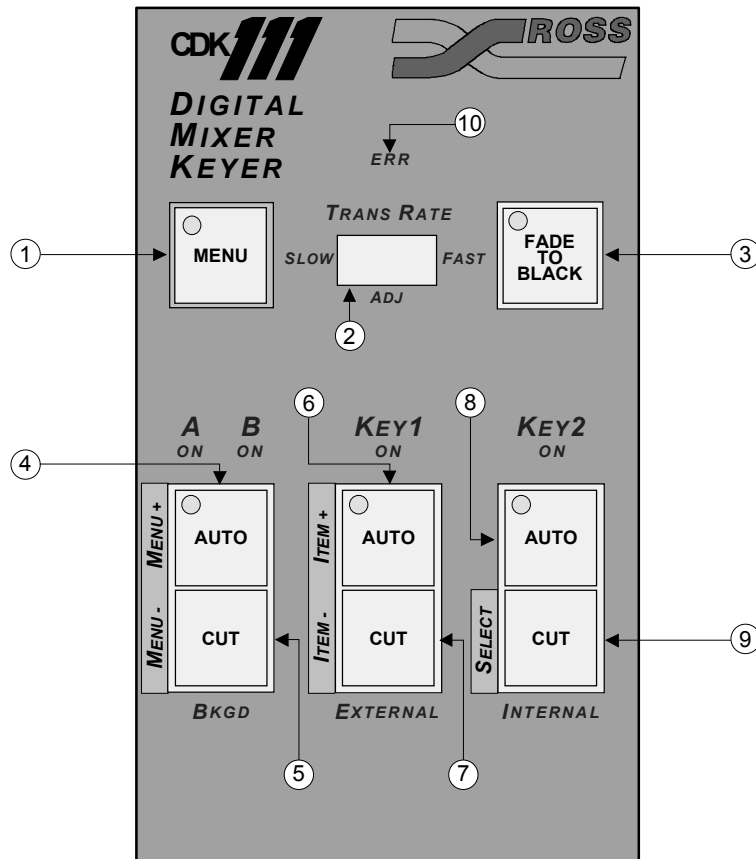

- | | | |
|-----------------------------|----------------------------|-------------------------------|
| 1) Menu Button | 5) BKGD Cut Button | 9) Key 2 Cut Button |
| 2) Trans Rate Toggle Switch | 6) Key 1 Auto Trans Button | 10) Secret Till Lit Error LED |
| 3) Fade To Black Button | 7) Key 1 Cut Button | |
| 4) BKGD Auto Trans Button | 8) Key 2 Auto Trans Button | |

DCP-111 Control Buttons

1) **Menu Button**

The Menu Button is used to enter and exit the menu system. Press and hold the Menu Button until the button light begins to flash. This will take approximately 3 seconds, after which the menu will appear as an overlay on the PGM monitor.

2) **Trans Rate Toggle Switch**

The Trans Rate Toggle Switch is used to quickly change the transition rate for the FTB, BKGD and Key transitions, to preset rates. There are three settings – slow, fast and adjustable. The fast rate is set for a 10-frame transition, while the slow rate is set for 45 frames. Toggling the switch to the center, adjustable position will use the transition rate set in the menu.

3) **Fade To Black**

- **Operation Mode** – pressing the Fade To Black button fades the PGM output to black or up from black, depending upon its present state, using either the control panel transition rate (see Trans Rate Toggle Switch) or the transition rate set in the menu.
- **Menu mode** – this button does not have a function when working in menu mode.

4) **BKGD Auto Trans Button**

- **Menu mode** – pressing the BKGD Auto Trans Button will change the on screen menu to the next menu in the 1–F menu sequence.

5) **BKGD Cut Button**

- **Menu mode** – pressing the BKGD Cut Button will change the on-screen menu to the previous menu in the 1–F menu sequence.

6) **Key1 Auto Trans Button**

- **Operation Mode** – pressing the Key1 Auto Trans Button will transition Key1 on or off.
- **Menu mode** – in the left-hand column, pressing the Key1 Auto Trans Button will move the cursor to the next item in the menu you are in. In the right-hand column, pressing the Key1 Auto Trans Button will step forward through the variables for that item.

7) **Key1Cut Button**

- **Operation Mode** – pressing the Key1 Cut Button will cut Key1 on or off air, depending upon its present state.
- **Menu mode** – when the cursor is in the left hand column (item column); pressing the Key1 Cut Button will move the cursor to the previous item. When the cursor is in the right hand column (value column), pressing the button will step backwards through the variables for that item.

8) **Key2 Auto Trans Button**

- **Menu mode** – this button does not have a function when working in menu mode.

9) **Key2 Cut Button**

- **Menu mode** – pressing the Key2 Cut Button will move the cursor to the sub-menu values in the right-hand column. The values in these sub-items can then be changed using the Key1 Auto Trans and Key1 Cut Buttons. Pressing the Key2 Cut Button again will return the cursor to the left-hand column.

10) **Secret Till Lit Error LED**

The Secret Till Lit Error LED mimics the CDK-111A-Lite card edge Error LED and lights only when an error condition is reached. View **Menu A: Diagnostics** to turn off the LED and find out the cause of the error.

GPIs and Tallies

This section describes GPI and Tally settings for the CDK-111A-Lite.

GPIs

This section explains how the GPI and Tally settings are structured in order to decrease set up time and maximize the capabilities of the CDK-111A-Lite.

Configure the GPI and Tally settings in **Menu E**.

GPI Functions

The following functions are available for GPI control:

- CUT KEY 1
- AUTO KEY 1
- AUTO FTB

GPI Triggers

GPI triggers can be configured as:

- EDGE HIGH
- EDGE LOW
- LEVEL HIGH
- LEVEL LOW

GPI Edge Triggers

Edge triggers are used when you want to toggle between settings. For the sake of comparison, pressing a card edge button or DCP-111 Control Panel button acts the same as the card receiving a GPI edge trigger. All of the GPI functions listed above can be triggered using GPI edge triggers.

Note

Edge triggered GPI signals should be stable at the selected level for 1 full frame of video to ensure the action will be triggered.

GPI Level Triggers

Level triggers are used when you want to assert a particular state for a setting. In this case, the user defines the on air state of the function as being either LEVEL HIGH or LEVEL LOW. Therefore, if the on air state of Key 1 is defined as LEVEL HIGH for example, as long as the GPI is a LEVEL HIGH signal, Key 1 will stay on air. If a LEVEL LOW GPI is received, Key 1 will be taken off air.

Note

GPI Level Triggers can be overridden by card edge, DCP-111, and protocol controls. Therefore, the states corresponding to a level setting can be changed by performing a transition with the other controls.

GPI Level State

Function	Equals Trigger State	Does Not Equal Trigger State
CUT KEY 1	Key 1 will be on air	Key 1 will not be on air
AUTO KEY 1	Key 1 will be on air	Key 1 will not be on air
AUTO FTB	CDK-111A-Lite will be faded to black	CDK-111A-Lite will not be at black

Tallies

This section explains how the Tally settings are structured in order to decrease set up time and maximize the capabilities of the CDK-111A-Lite.

Configure the GPI and Tally settings in **Menu E**.

Tally Functions

The KEY 1 function is available for Tally association.

Tally Outputs

Tally outputs can only be LEVEL HIGH or LEVEL LOW. They report the on air state of the Key. Therefore, if the on air state of Key 1 is defined as LEVEL HIGH for example, the Tally will continue to send a LEVEL HIGH signal until Key 1 is taken off air. When that happens, the Tally signal will change to LEVEL LOW, reporting the fact that Key 1 is off air.

This following table outlines the level of the tally output based on the function and setting.

Tally Level State

Function	Trigger Set To Level High	Trigger Set To Level Low
KEY 1	Tally high if Key 1 on air Tally low if Key 1 off air	Tally low if Key 1 on air Tally high if Key 1 off air

The Menu System

The CDK-111A-Lite is configured through a menu system. Each card is set up individually and can respond to commands from a variety of sources, most often from serial control devices such as switchers, computers, or edit controllers. Although each card can be operated using its card edge controls or a control panel, often it will be controlled from a remote device. Various menu options must be selected so that the card can read signals from the various remote devices. This section provides detailed descriptions of the menus and their item options.

Menu Feature Descriptions

The menus are laid out like the menu shown below:

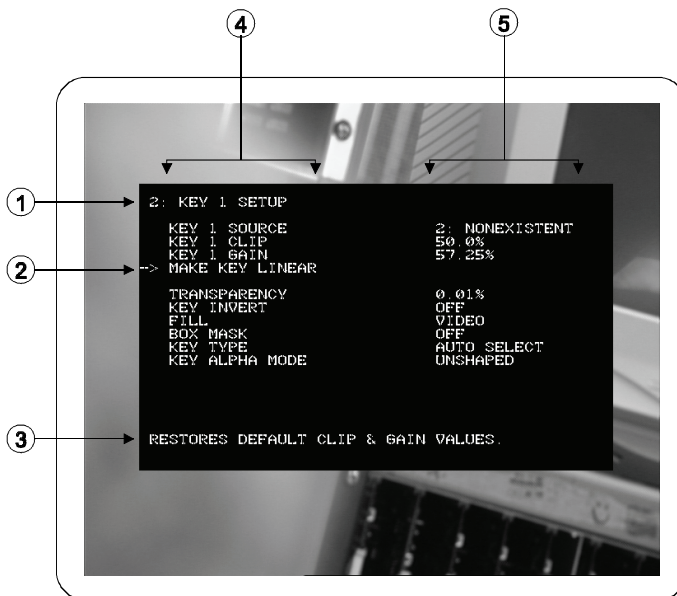

1) Menu Number and Title	3) One Line Help	5) Value Column
2) Menu Cursor	4) Item Column	

1) Menu Number and Title

The 15 menus are numbered 1 to F. Each has a title, which describes the focus of that particular menu. Position **0** is reserved for standalone keyer operation mode.

2) Menu Cursor

The menu cursor can be moved up and down the left hand column using the card edge controls or the control panel buttons. It can also be moved to the right hand column to change the values associated with the item.

3) One Line Help

Some items have a One Line Help line at the bottom of the menu, which provides a brief explanation of that item.

4) Item Column

The left hand column is a list of items, which provide information about the card or item headings which require configuration.

5) Value Column

The right hand column displays the value of its associated item.

Menu Titles

Menu titles	
1	Runtime Parameters
2	Key 1 Setup
3	Reserved For Future Use
4	Box Mask Positioning
5	Matte Selection
6	Reserved For Future Use
7	Reserved For Future Use
8	Image Freezing, Storage, and Deletion
9	Input / Output Delays
A	Diagnostics
B	Reserved For Future Use
C	Secondary Card Setup
D	Card Setup
E	Tally / GPI Setup
F	BNC Listing

The following is a detailed listing of all 15 menus, including variables, that are used during the card configuration. The menus have been formatted in this guide so that if you wish, you can photocopy these pages and take them with you as you configure the individual cards in your facility. Where applicable, default settings are indicated in the descriptions.

Menu 1: Runtime Parameters

Menu 1: Runtime Parameters	
Auto Trans Rate	<p>This value is the rate in frames at which a key dissolves on or off. Transition rates cannot be changed while a transition is in progress. If you would like your transitions to be cuts, change this value to 1 frame, or use a Cut button on the DCP. For serial control, the transition rate should be sent immediately preceding or as part of the Start Transition command.</p> <ul style="list-style-type: none"> • In 525 line systems (NTSC), 30 frames equal 1 second. • In 625 line systems (PAL), 25 frames equal 1 second.
FTB Trans Rate	<p>This value is the rate in frames at which the fade to black will take to complete.</p> <ul style="list-style-type: none"> • In 525 line systems (NTSC), 30 frames equal 1 second. • In 625 line systems (PAL), 25 frames equal 1 second.
BKGD 1 Source	<p>Your available option is BNC IN – Live video from the BNC labeled ‘IN’.</p>
Key 1 Status	<p>This will display if Key 1 is currently on air. You can change this manually here if you desire.</p> <p>Your available options are:</p> <ul style="list-style-type: none"> • ON AIR – Key 1 is currently on air. • OFF AIR – Key 1 is currently off air. (default setting)

Menu 2: Key1 Setup

Menu 2: Key1 Setup	
Key1 Source	<p>BNC 7 and 8 – Key 1 will use the external key inputs on BNC 7 and 8.</p>
Key1 Clip	<p>The CDK-111A-Lite is a linear luminance keyer. This means that the shape of the key on screen is determined by the luminance values of the alpha signal (BNC 8 for an external key), in conjunction with the clip and gain values. (default setting is 50%)</p> <p>The clip value sets a threshold value for the luminance in the alpha signal. Every luminance value in the alpha signal that is greater than the clip value is shown in the key, and no luminance value in the alpha signal that is less than the clip value is shown as part of the key.</p> <p>A clip value of 0.0% means that the key video will be displayed full screen, and none of the background video will be visible.</p> <p>A clip value of 100.0% means that the key video will <i>not</i> be visible at all regardless of whether the key is on air or not.</p>
Key1 Gain	<p>Key gain determines the size of a range around the clip level setup in key clip. A gain value of 100.0% has a range size of 0 around the key clip. (default setting is 57.24%)</p> <p>A key gain value of 100.0% is referred to as a ‘Hard key’. A hard key has no transparency in it. Every value of the alpha signal that is above the clip level is shown fully on the program video, whereas no value of the alpha signal that is below the clip level is shown in the program video at all.</p> <p>Lower gain values increase the size of the range around the key clip. Values of the luminance level of the alpha signal that fall within this range will now start to appear in the program monitor as transparent. Luminance values at the very bottom of this range will be fully transparent, and as the luminance values approach the top values in the range, the key will become less and less transparent.</p>
Make Key Linear	<p>Selecting this item will force the Clip and Gain values to their default settings.</p>

Menu 2: Key1 Setup	
Transparency	The transparency value is applied to the key after the clip and gain values are set. The default value of 0.0% will leave the key output on the PGM output unchanged. As the transparency value is increased, the key output on the PGM will become increasingly transparent.
Key Invert	ON/OFF. Turning the key invert on will invert the portions of the program video that come from the background video, and the portions that come from the key video. (default setting is OFF)
Fill	The fill setting allows you to choose whether your key is filled with video or with a constant matte color. Your available settings are: <ul style="list-style-type: none"> • VIDEO – Key will be filled with video. (default setting) • MATTE – Key will be filled with a constant matte color. The color is chosen in menu 5.
Box Mask	ON/OFF. This setting allows you to turn on or off the box mask. The box mask can only be used when the keyer is set to use an external key (BNC 7 and 8). (default setting is OFF)
Key Type	Keys on the CDK-111A-Lite can be of two types, auto select keys or self keys. <ul style="list-style-type: none"> • Auto Select key – The shape of the key is determined by the luminance values in the alpha channel. (BNC 8 for an external key) (default setting) • Self key – The shape of the key is determined by the luminance values in the video image itself. (BNC 7 for an external key) <p>You should choose an auto select key in almost all circumstances. Any device, which provides a separate alpha signal, will be used as an auto select key. Therefore, character generators are used as auto select keys.</p> <p>The only time you would choose a self key would be if you were trying to key from a source that did not have a separate alpha channel such as a camera or VTR source.</p>
Key Alpha Mode	There are two types of linear luminance keys, Shaped, and Unshaped (default setting). Every key provided to the CDK-111A-Lite into BNC 7 and 8 will be one of these two types. You should ensure that the key type chosen inside the CDK-111A-Lite menu matches the key type that you are providing to the card. If you are unsure of which key type to use you are best off picking unshaped. The major hint that you have the wrong key type selected is if the edges of your key appear incorrect. In that case, return to the menu and select the other key type. Shaped keys use fixed clip and gain values and no transparency value. Therefore, users cannot change clip, gain, or transparency values while the system is set to use shaped keys.

Menu 3: Reserved For Future Use

Menu 3: Reserved For Future Use

Menu 4: Box Mask Positioning

Menu 4: Box Mask Positioning	
A box mask allows you to choose a region of the screen where the key will not be displayed regardless of any other settings. This mask can be used to hide portions of a key that you no longer wish to display, or, by turning the mask on and off, it gives you the ability to reveal and hide portions of the key on the program output.	
Top Edge Position	0-100%. Moves the top edge of the box mask (default setting is 30%)
Bottom Edge Position	0-100%. Moves the bottom edge of the box mask (default setting is 70%)
Left Edge Position	0-100%. Moves the left edge of the box mask (default setting is 30%)
Right Edge Position	0-100%. Moves the right edge of the box mask (default setting is 70%)
Mask Invert	The choices are: <ul style="list-style-type: none"> • OFF – The area <i>inside</i> the box will hide the key. (default setting) • ON – The area <i>outside</i> the box will hide the key.

Menu 5: Matte Selection

Menu 5: Matte Selection	
The matte is the color that is used when a key is set to Matte Fill.	
Hue	0% = blue (default setting), 100% = blue again, with the color spectrum between. If you have a selected key set to Matte fill, it will show in a preview window on the menu.
Saturation	Color saturation is defined as the depth of the selected color. Use this to make a distinction between a pale red and a deep red, for example. A value of 0.0% will give no depth, i.e., you will get a shade of grey. A value of 100.0% will give you the maximum depth for your chosen color. (default setting is 50%)
Luminance	Luminance is defined as the brightness of the selected color. 0.0% will give you black, 100.0% will give you white. Please note that regardless of your selected hue and saturation, as you approach 0.0% or 100.0% your color will approach black and white. (default setting is 50%)

Menu 6: Reserved For Future Use

Menu 6: Reserved For Future Use	

Menu 7: Reserved For Future Use

Menu 7: Reserved For Future Use	

Menu 8: Image Freezing, Storage, and Deletion

Menu 8: Image Freezing, Storage, and Deletion	
(Un)freeze Key + Alpha	When the select button is pressed on this item, the video currently being used in the external key input buffers (Key 1) will be frozen.

Menu 9: Input/Output Delays

Menu 9: Input/Output Delays	
Video Format	This item displays "PAL" or "NTSC" as appropriate for the video format being used. (Information only, cannot be changed.)
Current Reference Source	This item displays the reference source the card is currently using. (Information only, cannot be changed.)
Reference Source Select	This item selects which reference to use. The options are: <ul style="list-style-type: none"> EXTERNAL REF – Analog house sync reference signal from frame. BNC IN REF – Digital reference from BNC IN video input. AUTO DETECT – Uses whichever signal is present. (Default setting)
Ref. To Output Delay	This item sets a delay (up to one frame) from the start of the reference frame to the start of the output frame within a range of: <ul style="list-style-type: none"> NTSC: 0-525 Lines, 0-1716 Samples PAL: 0-625 Lines, 0-1728 Samples
Input To Output Delays: These items describe delay ranges in clock units up to one frame from the start of the input frame to the start of the output frame at each BNC.	
BKGD 1	# Lines, # Samples. Information only, cannot be changed.
Key Fill	# Lines, # Samples. Information only, cannot be changed.
Key Alpha	# Lines, # Samples. Information only, cannot be changed.

Menu A: Diagnostics

Menu A: Diagnostics	
<p>The Error LED on the card edge will turn on in the following circumstances:</p> <ul style="list-style-type: none"> An error in an incoming video source has been detected and you have programmed the card to report those errors to you. The error LED on the card will stay on until the video error has been corrected. <p>You have the option in this menu of turning off the reporting of these video errors on an input-by-input basis. If you are not going to be attaching video to any input, you should turn error reporting off for it, as this would cause the error LED to be on constantly, negating its usefulness.</p> <ul style="list-style-type: none"> An internal error of some kind has occurred. These errors can be anything from a communication error to a failure of some internal diagnostics. <p>This menu will display the last 50 internal errors that have occurred and how long it has been since that error occurred.</p> <p>When a new internal error occurs, the Error LED will turn on. Once this error has been viewed in this diagnostics menu, the Error LED will turn off.</p>	
BKGD 1 Video	<p>The choices are:</p> <ul style="list-style-type: none"> LED ON IF ERROR – The error LED will turn on whenever there is a video error on BKGD 1 Video. LED OFF IF ERROR – Video errors on BKGD 1 will be reported in the menu, but LED will not light.
Key Video	<p>The choices are:</p> <ul style="list-style-type: none"> LED ON IF ERROR – The error LED will turn on whenever there is a video error on Key Video. LED OFF IF ERROR – Video errors on Key Video will be reported in the menu, but LED will not light.
Alpha Video	<p>The choices are:</p> <ul style="list-style-type: none"> LED ON IF ERROR – The error LED will turn on whenever there is a video error on Alpha Video. LED OFF IF ERROR – Video errors on Alpha Video will be reported in the menu, but LED will not light.
<p>At the bottom of the menu area, the error message type and the time since the error occurred are displayed. The messages can be scrolled using the up/down buttons. These items cannot be changed and are for reporting purposes only.</p> <p>There are two types of errors that will appear here – Operational and Internal errors.</p> <p>Operational errors are not necessarily a problem; the occasional checksum failure on communication protocols for example, is quite ordinary. However, the same error repeatedly should be investigated.</p> <p>Internal errors will be marked by the text “Internal Error #: xxx”, where xxx is replaced by a number. These errors should never appear. If you encounter them, please call Ross Video Customer Service and report them.</p>	

Menu B: Reserved For Future Use

Menu B: Reserved For Future Use

Menu C: Secondary Card Setup

Menu C: Secondary Card Setup	
Dithering	<p>This will set dithering values.</p> <ul style="list-style-type: none"> • NONE – function disabled. (default setting) • +/- 3 – random values applied to last 2-bits. • +/- 7 – random values applied to last 3-bits. • +/- 15 – random values applied to last 4-bits.
Rounding	<p>This will set rounding values.</p> <ul style="list-style-type: none"> • NONE – function disabled. (default setting) • 8 BIT – lose least significant bits until 8 are left. • 10 BIT – lose least significant bits until 10 are left.
Clipping	<p>This will set clipping values.</p> <ul style="list-style-type: none"> • SMPTE – The CDK-111A-Lite will clip all values beyond this standard's ranges with this option selected. (default setting) • ALLOW SUPERBLACK – adds superblack range to SMPTE range. • ALLOW SUPERWHITE – adds superwhite range to SMPTE range. • ALLOW ALL – adds superblack and superwhite ranges to SMPTE range.
Board Address	<p>The (hex) board address is used for some external protocols to identify the card. (default setting is 30H)</p>

Menu D: Card Setup

Menu D: Card Setup	
Software Version	<p>This is the version of software loaded on the card. (For informational purposes only and can not be changed.)</p>
FPGA Version	<p>This is the version of hardware firmware resident on the card. (For informational purposes only and can not be changed.)</p>
Card Type	<p>This is the model of CDK-111A-Lite you have purchased. (For informational purposes only and can not be changed.)</p>
Keyer Type	<p>STANDALONE KEYER – For using the keyer as a standalone unit or in a master control application.</p>
Protocol	<p>You have the following choices:</p> <ul style="list-style-type: none"> • GVG 100 – Choose this (default) option if you are going to be controlling your CDK-111A-Lite using the GVG 100 protocol. If you choose this option, you <i>must</i> have BNC 3 set to COMM RX and BNC 4 set to COMM TX. See Appendix A, “Serial Protocols”, for more information on protocol commands. (default setting) • MASTER 2100 – Choose this option if you are going to be controlling your CDK-111A-Lite using the Master 2100 protocol. If you choose this option, you <i>must</i> have BNC 3 set to COMM RX and BNC 4 set to COMM TX. See Appendix A, “Serial Protocols”, for more information on protocol commands. • NONE – Choose this option if you are <i>not</i> going to be controlling the CDK-111A-Lite using a remote control protocol.

Menu D: Card Setup	
Test Pattern Selection	<p>This allows you to choose from the following built in test patterns, which the card will output when you have Display Test Pattern set to ON.</p> <ul style="list-style-type: none"> • COLOR BARS 75% (default setting) • FLATFIELD BLACK • PLL PATHOLOGICAL • EQ PATHOLOGICAL
Display Test Pattern	ON/OFF. Press Select button to view test pattern.
BNC 2	<p>BNC 2 can be configured in one of three ways – either as the I/O for the control panel, an input for a GPI, or as a Tally output. To configure BNC 2 as a:</p> <ul style="list-style-type: none"> • CONTROL PANEL – When selected, bridge jumper J6 (see card diagram at the beginning of Chapter 2, “Installation and Setup”, for the location of J6) on the card at pins 3 and 4. See Appendix C, “Specifications” for jumper pinout reference. (default setting) • GPI # – When selected, bridge jumper J6 (see card diagram at the beginning of Chapter 2, “Installation and Setup”, for the location of J6) at pins 1 and 2. See Appendix C, “Specifications” for jumper pinout reference. • TALLY # – When selected, bridge jumper J6 (see card diagram at the beginning of Chapter 2, “Installation and Setup”, for the location of J6) on the card at pins 5 and 6. See Appendix C, “Specifications” for jumper pinout reference.
BNC 3	<p>BNC 3 can be configured in one of three ways – either as an RX input, a GPI input, or as a Tally output. To configure BNC 3 as an,</p> <ul style="list-style-type: none"> • COMM RX – If GVG100 or Master2100 protocol is selected above, BNC 3 <i>must</i> be set to this option. (default setting) • GPI #2 – Uses BNC 3 as GPI #2. • TALLY #2 – Uses BNC 3 as Tally #2. <p>NOTE: If BNC 3 is configured as an RX input, ensure that BNC 4 is set to the corresponding TX configuration.</p>
BNC 4	<p>BNC 4 can be configured in one of three ways – either as a TX output, a GPI input, or as a Tally output. To configure BNC 4 as a,</p> <ul style="list-style-type: none"> • COMM TX – If GVG100 or Master2100 protocol is selected above, BNC 4 <i>must</i> be set to COMM TX. (default setting) • GPI #3 – Uses BNC 4 for GPI #3. • TALLY #3 – Uses BNC 4 for Tally #3.
Factory Default	Selecting the Factory Default will reset all values on the card to the initial factory default settings and reset the card itself.

Menu E: Tally / GPI Setup

Menu E: Tally / GPI Setup	
GPI #1 (BNC 2)	<p>GPI Function for GPI #1. This is only used if BNC 2 is set to GPI #1 in Menu D: Card Setup and jumper J6 is bridged at pins 1 and 2.</p> <ul style="list-style-type: none"> • USED FOR COMM (default setting) • USED FOR TALLY • AUTO FTB • AUTO KEY 1 • CUT KEY 1
GPI #1 Trigger	<p>GPI Trigger for GPI #1.</p> <ul style="list-style-type: none"> • EDGE HIGH (default setting) • EDGE LOW • LEVEL HIGH • LEVEL LOW
GPI #2 (BNC 3)	<p>GPI Function for GPI #2. This is only used if BNC 3 is set to GPI #2 in Menu D: Card Setup. See GPI #1 list for options available here. (same default settings as BNC 2)</p>
GPI #2 Trigger	<p>GPI Trigger for GPI #2. See GPI #1 Trigger options. (same default settings as BNC 2)</p>
GPI #3 (BNC 3)	<p>GPI Function for GPI #3. This is only used if BNC 4 is set to GPI #3 in Menu D: Card Setup. See GPI #1 list for options available here. (same default settings as BNC 2)</p>
GPI #3 Trigger	<p>GPI Trigger for GPI #3. See GPI #1 Trigger options. (same default settings as BNC 2)</p>
Tally #1 (BNC 2)	<p>Tally Function for Tally #1: This is only used if BNC 2 is set to TALLY #1 in Menu D: Card Setup and jumper J6 is bridged at pins 5 and 6.</p> <ul style="list-style-type: none"> • USED FOR COMM (default setting) • USED FOR GPI • KEY 1
Tally #1 Trigger	<p>Tally Trigger for Tally #1.</p> <ul style="list-style-type: none"> • LEVEL HIGH (default setting) • LEVEL LOW
Tally #2 (BNC 3)	<p>Tally Function for Tally #2: This is only used if BNC 3 is set to TALLY #2 in Menu D: Card Setup. See Tally #1 list for options available here. (same default settings as BNC 2)</p>
Tally #2 Trigger	<p>Tally Trigger for Tally #2.</p> <ul style="list-style-type: none"> • LEVEL HIGH (default setting) • LEVEL LOW
Tally #3 (BNC 4)	<p>Tally Function for Tally #3: This is only used if BNC 4 is set to TALLY #3 in Menu D: Card Setup. See Tally #1 list for options available here. (same default settings as BNC 2)</p>
Tally #3 Trigger	<p>Tally Trigger for Tally #3.</p> <ul style="list-style-type: none"> • LEVEL HIGH (default setting) • LEVEL LOW

Menu F: BNC Listing

Menu F: BNC Listing	
This menu is for informational purposes only. The BNC listing is designed for easy reference during card configuration and troubleshooting. This menu reflects configurations set in Menu D.	
BNC IN	BKGD 1 INPUT (default setting)
BNC 1	Unused
BNC 2	Depends upon card configuration (GPI, CONTROL PANEL (default setting), or TALLY)
BNC 3	Depends upon card configuration (GPI, TALLY, or RX (default setting))
BNC 4	Depends upon card configuration (GPI, TALLY, or TX (default setting))
BNC 5	PROGRAM (default setting)
BNC 6	PROGRAM (default setting)
BNC 7	KEY VIDEO INPUT (default setting)
BNC 8	KEY ALPHA INPUT (default setting)
Key 1 Status	Whether Key 1 is currently ON AIR or OFF AIR (default setting).
FTB Status	ON/OFF (default setting). Whether the card is currently faded to black or not.
Time Active	The time begins counting up when the card is powered on. If the card continues to be in service with uninterrupted power for a period of approx. 2 ¼ years, it will reset to 0 and begin counting up again.

Appendix A. Serial Protocols

In This Appendix

This appendix describes the communications protocol systems used with the CDK-111A-Lite.

Note

Only those who are developing a custom serial interface to the CDK-111A-Lite will require the contents of this Appendix.

The following topics are discussed:

- GVG 100 Emulation Protocol
- Protocol Elements
- Editor Interface State Diagram
- Protocol Command Descriptions
- Additions to GVG 100 Emulation Protocol
- GVG MASTER2100 Emulation Protocol
- GVG MASTER2100 Emulation Commands

GVG 100 Emulation Protocol

This protocol system is based on the GVG 100 Serial Interface Protocol (Manual Number: TP0273-01). (GVG is a registered trademark of Thomson Grass Valley.)

It is intended for editors designed to control the following switchers:

- GVG 100
- GVG 110
- RVS 210A
- RVS 216A
- RVS 210D
- RVS 216D
- Synergy 100

It will also be able to control a CDK-111A-Lite keyer without modification.

The figure below highlights the buttons on a GVG 110 switcher that have CDK-111A-Lite equivalents.

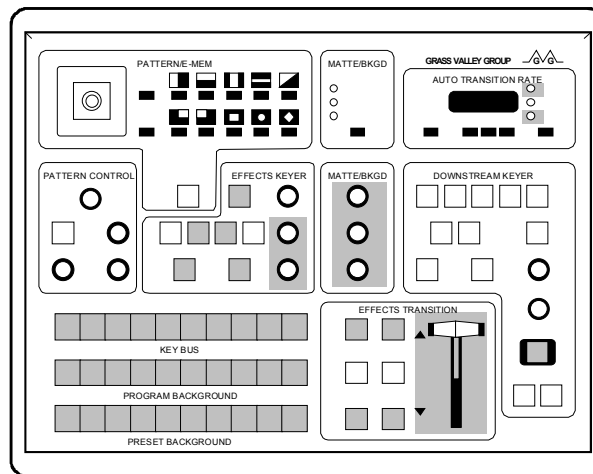

GVG 110 Panel

General Description

The CDK-111A-Lite serial interface provides a communication link between a computer based editing system or automation system and the keyer. The CDK-111A-Lite has provisions for every parameter to be controlled.

The major functions accessible via the protocol are:

- KEY BUS input button (crosspoint) selection
- push-button / lamp control
- analog control settings (knobs)
- transition and auto transition control (selections and rate settings)

These functions are described in the following pages.

By means of “read” and “write” operations, the protocol allows the editor to configure and control the keyer. In general, read operations determine the current status of keyer controls and write operations set controls and make selections on the keyer.

The editor serial interface is fixed at RS-485 transmission standard and operates at a baud rate of 19,200.

Editor Transmission Standard

The CDK-111A-Lite is factory shipped with:

- 19,200 baud, ODD parity, one stop bit, 8 data bits and
- a select address of 30 (hexadecimal)

The default select address of 30 assumes that the “Board ID” rotary switch at the card edge is in position **0**. Changing the select address is discussed in the section “**Address Byte (Editor Select Address)**” later in this Appendix.

Editor Connector Pinouts

The CDK-111A-Lite provides an unbalanced full duplex RS-485 or 0-12V RS-232 compatible interface.

The signals on the rear of the RossGear chassis have been named from the point of view of the CDK-111A-Lite. An editor serial interface will require the use of BNC 3 and 4.

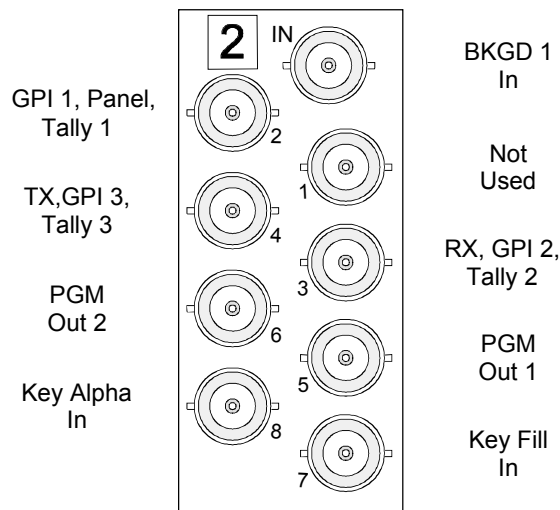

CDK-111A-Lite Connectors

The CDK-111A-Lite uses a single-ended interface with the normally positive-going signals always set to ground. This is because the coax connector has only one signal pin and the surrounding shield is grounded as a standard feature of the chassis. This will inherently limit the noise immunity of the connection and care must be taken when controlling the CDK-111A-Lite in noisy environments or over long cable runs.

Protocol Elements

The recommended wiring to a controller using a standard single-ended unbalanced full duplex RS-485 or 0-12V RS-232 compatible interface is as follows:

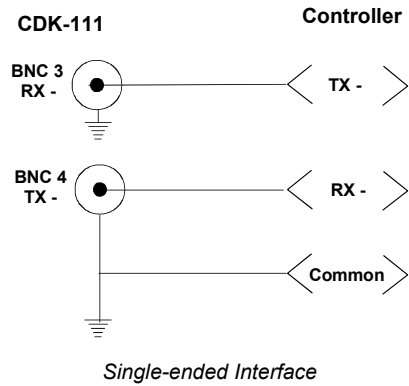

If differential input is required, the recommended CDK-111A-Lite to controller wiring is as follows. Note the bias of approximately two volts on the RX minus input connection, internal to the controller:

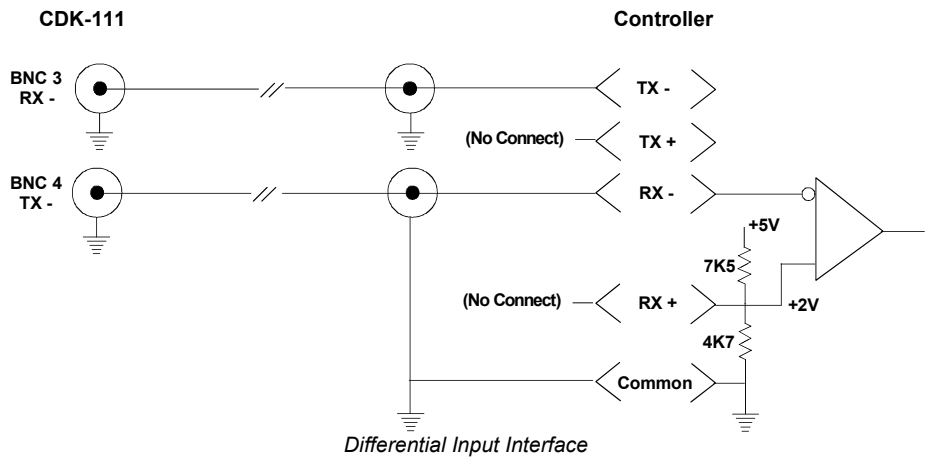

The components of the serial data are shown in the figure below. These are:

1. The break character, to prepare the serial interface for communication.
2. An address byte, to select the keyer as the device to communicate with the editor. For the CDK-111A-Lite, this is factory shipped as 30H (Hex) with the ability to change it to any legal value.
3. The command / message blocks, which actually direct keyer operation. The structure of these blocks is discussed in the next sections.

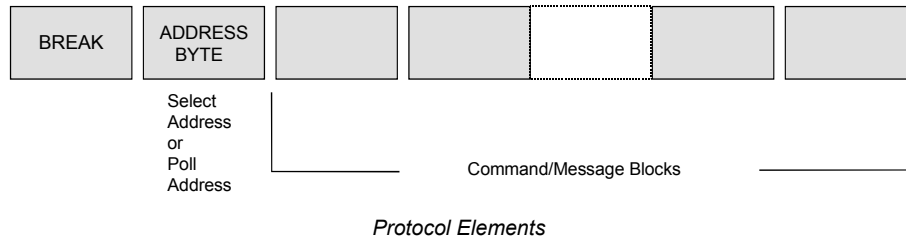

Break Character (00)

The break character is sent by the editor to the serial port of the keyer to prepare it for receipt of further data. The break character puts the editor interface into the “active” state. After receipt of the break character, the keyer ceases all bus communications, resets any communication errors, empties the receive buffer of all pending commands, and awaits receipt of an address byte. The break character is composed of 17 to 20 bits of spacing data (low logic level) followed by a minimum of two bits of marking data (high logic level).

Address Byte (Editor Select Address)

Following receipt of the break character, the editor interface will expect a one-byte address, either the Select Address or the Poll Address. Most often, the address sent is the Select Address. The editor select address identifies the keyer as the device to communicate with the editor.

The Select Address must always be an *even* number. The Poll Address equals the Select Address plus “1”, and is sent by the editor to determine if the keyer is on the bus. If the keyer is present (active), it sends an “acknowledge byte” of 84H (Hex) back to the editor and remains in the active state. The keyer is now ready to accept continuous command/message transmission from the editor without going through the initial break/address sequence again. Any communication errors or “time outs” cause the keyer to send a “negative acknowledge byte” of 85H, reject any unexecuted commands, and return to the idle state.

Receipt of any other device’s Select Address also causes the serial interface to enter the idle state, requiring the break/address sequence to be performed before the communication can be restored. If another device’s Poll Address is received, it is ignored and the serial interface remains in the active state.

The Select Address is set on the CDK-111A-Lite via the rotary **Board ID** dial at the card edge. The select address for the keyer is the indicated Board ID on the dial *multiplied by 2*. If zero is selected, the Select Address is determined by navigating to the on-screen menu system. The on-screen menu system allows the selection of any legal select address (00-FC, *even* numbers).

Note

Do *not* use address FE. It is reserved for a “**Broadcast All**” signal that is used by the controller to send a message to every card in the chain.

Note also that when the “**Broadcast All**” message is sent, the cards perform the broadcasted command but do not respond to the controller with any completion or acknowledgement reply.

As a quick reference, the table below shows the Board ID vs. Select Address settings. All numbers are in hexadecimal.

Board ID vs. Select Address

Board ID	Select Address	Board ID	Select Address
0	Via Menu	8	10
1	02	9	12
2	04	A	14
3	06	B	16
4	08	C	18
5	0A	D	1A
6	0C	E	1C
7	0E	F	1E

Command/Message Block Structure

Once selected, the serial interface receives data from the editor in the form of command/message blocks that direct keyer operation. The blocks are structures as shown below.

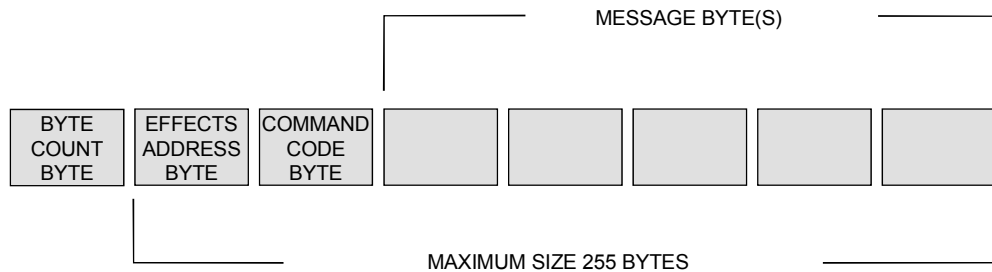

Command / Message Block Structure

The serial interface can operate continuously, allowing multiple keyer operations to be performed without cycling constantly through the break/address sequence described earlier. The individual sections comprising the command/message blocks are discussed in the following paragraphs.

The keyer executes commands in the first odd vertical interval after the command is received. A command is considered received when the last byte of data arrives. The figure below shows the keyer response timing. The beginning of the vertical interval is the timing reference for the system.

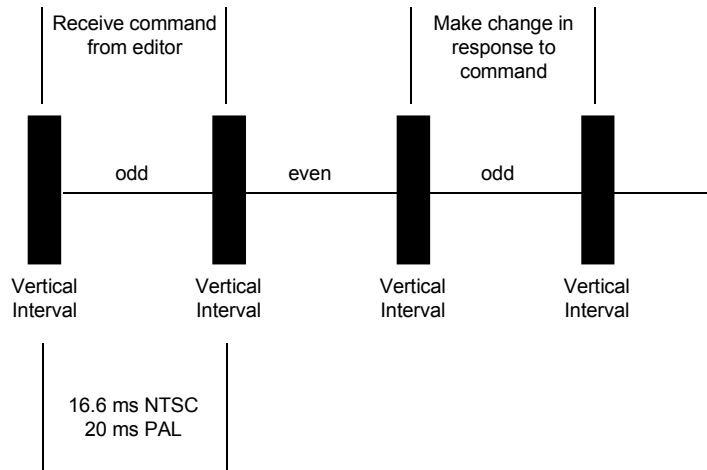

Byte Count Byte

The command/message blocks can vary in size from 2 to 255 bytes. The byte count, the number of subsequent bytes in the block, is contained in the first byte of the block. The byte count byte is not included in the byte count so the byte count range is 1 to 255 (01H to FFH). Upon receipt of a valid byte count and the correct number of bytes, the command is carried out.

Effects Address Byte

The Effects Address Byte (sometimes referred to as “EX”) should be set up to 01. In order to ensure compatibility with the majority of editing systems, the setting of the Effects Address Byte is ignored where possible.

Command Code Byte (Read, Write)

The third byte of the command/message block is the command code byte. It is either a read or a write command. Either type of command can be sent at any time, but not at the same time. When the keyer receives a write command, a two-byte status message is sent to the editor and the command is carried out. The characteristics of these commands are described below:

1. Read Commands

Read commands allow the editor to determine the status of specified parameters of keyer operation. For example, a read command may be used to determine if Key Invert is currently selected or to determine the current setting of the CLIP control.

The keyer responds to a read command from the editor by returning the status of the parameter specified in the read command. This status information is returned in the format of a write command.

Message bytes following the command code may or may not be required for read commands, depending on the specific command. Message bytes are discussed in the next section.

2. Write Commands

Write commands are used by the editor for operations that configure the keyer or update its parameters, such as adjusting the setting of an analog control or starting an auto transition.

The keyer responds to a write command by returning a two-byte status message. The first byte count is set to 01H. The second contains the keyer response to the command. The format of this second byte is as shown below.

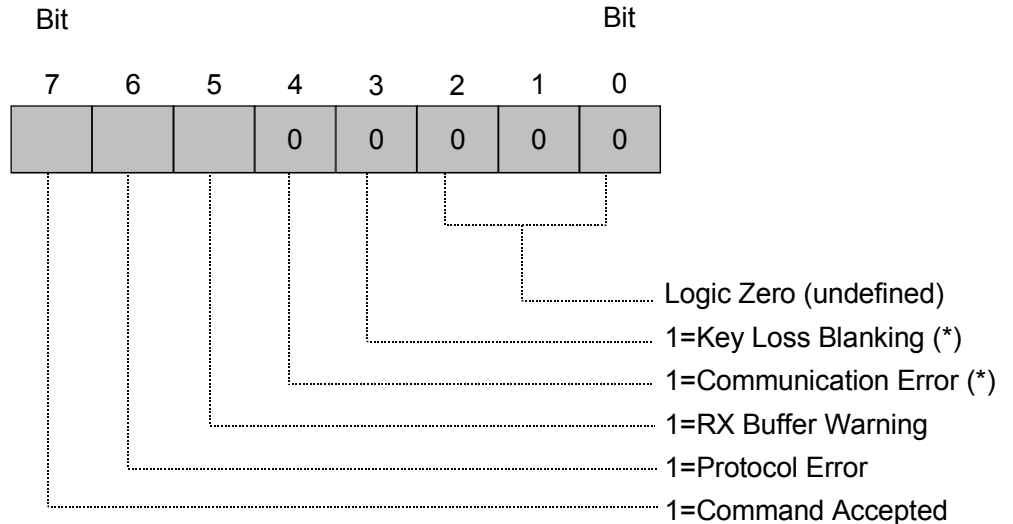

*= if enabled

Write Command – Format of Second Byte

If bit 6 or bit 7 is high, the meaning is as follows:

- Protocol Error – If bit 6 is high (logical “1”), an illegal function may have been specified.
- Command Accepted – If bit 7 is high (logical “1”), then the command has been accepted.
- Rx Buffer Warning – High when the receive buffer is very close to full and in danger of dropping messages. *(Not currently implemented)*
- Communication Error bit – High if a communication error has occurred since the last break command while placing characters in the command queue. *(Not currently implemented)*
- Key Loss Blanking – Set when an on-air key is not displayed on the PGM output because a key signal (alpha or fill or background) is missing or bad. *(Not currently implemented)*

Message Bytes

The number of message bytes that follow a command code byte depends upon the command. The command code to read an analog control, for example, requires message bytes in order to identify the control to be read while the command code to read the MLE 1 PST bus (to determine which input is selected) requires no message byte(s).

Write commands require at least one message byte, specifying the control parameter (for example, an input number – one byte) being changed. When an analog control setting is being changed, additional message bytes are required to indicate the new value to which the analog control is to be set.

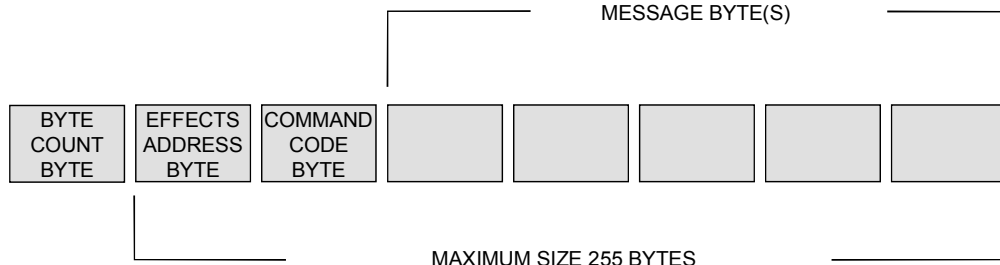

Command/Message Structure – Message Bytes

Editor Interface State Diagram

Now that an overview of all elements of the protocol has been presented, here is a summary of how the keyer processes editor commands:

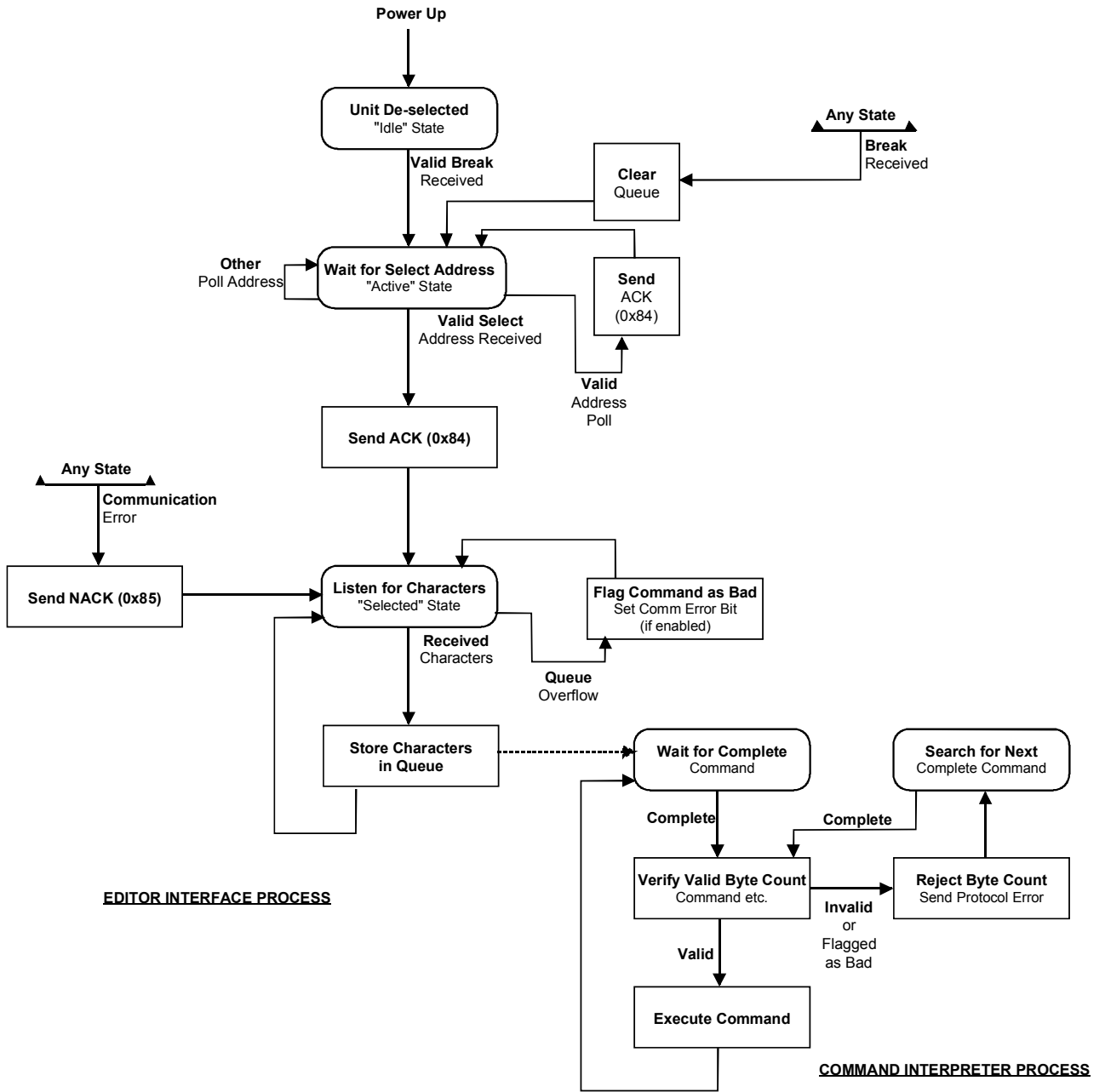

Editor Interface State Diagram

Protocol Command Descriptions

List of Commands

The following list shows the order of the protocol commands in this section.

If your application requires further Leitch DSK protocol command support, please contact Ross Video with this request.

Note

All numbers in the following tables are in hexadecimal
--

Command Descriptions

Command Name	Read Code	Write Code
Crosspoint	41-44	C1-C4
Analog Control	45	C5
Push-button/Lamp Control	46/47	C6/C7
Transition Mode	4A	CA
Auto Transition Rate	4C/7C/7D	CC/FC/FD
All Stop	n.a.	F2
Push-button Select	n.a.	FB
Software Version	6C	EC
Card Status	73	74
Error Status	71	72

n.a. = not applicable

Crosspoint Command (41-44, C1-C4)

The editor uses the read form of the crosspoint command to determine which input crosspoint is selected on the key bus. The response from the switcher will be in the form of a write command, with the message data containing the input number.

The write command allows the editor to select and input.

Note

The CDK-111A-Lite keyer will treat commands 43/44 as identical and C3/C4 as identical to ensure compatibility with most editors.

Crosspoint Command (41-44, C1-C4)

Function	Byte Count	Effects Address	Command Code	Message
READ:				
PGM Bus	02	01	41	None
KEY Bus 1 Fill	02	01	43	None
KEY Bus 2 Fill	02	01	44	None
WRITE:				
PGM Bus	03	01	C1	Input Number
KEY Bus 1 Fill	03	01	C3	Input Number
KEY Bus 2 Fill	03	01	C4	Input Number

The internal design of the CDK-111A-Lite allows any external or internally generated input to be routed to any bus. The message byte therefore can take on any of the following:

Message Bytes

Input Number (hex)	Meaning
00	Internal Black
01	Video In A
03	Video In Key Fill
04	Video In Key Alpha
05	Internal Matte

Analog Control Command (45, C5)

The editor uses the read form of this command to determine the current value of the analog control identified in the command. The response from the keyer will be in the form of the write command, the message data (three bytes) containing the control number being read (first byte) and the current value of this control (second and third bytes). The control number assigned to each analog control is listed in the table on the next page.

A write command from the editor updates the analog control to a new value. The control value setting is represented in the message by two bytes, forming a signed 16 bit two's complement number. Valid numbers range from -4096 to +4095 for bipolar controls and 0 to +4095 for unipolar controls. The format is as shown in the figures below.

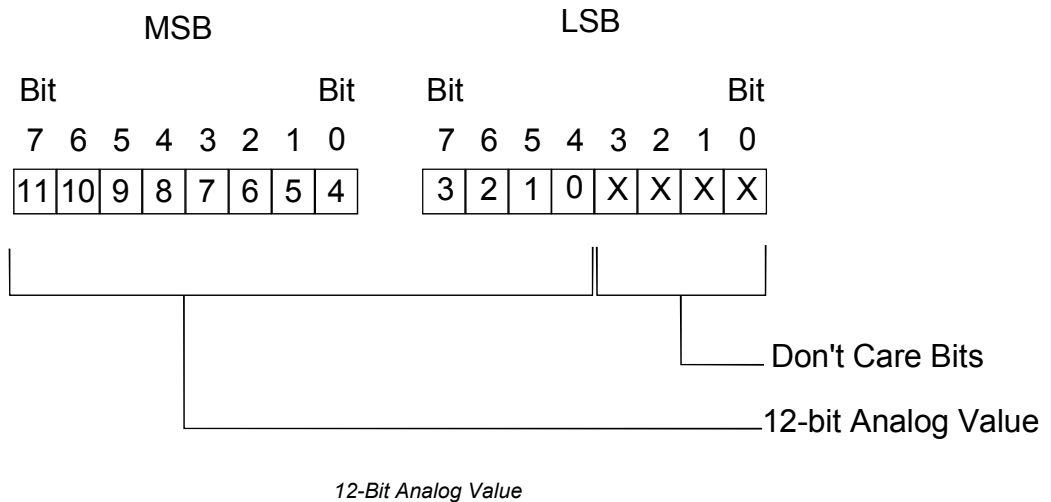
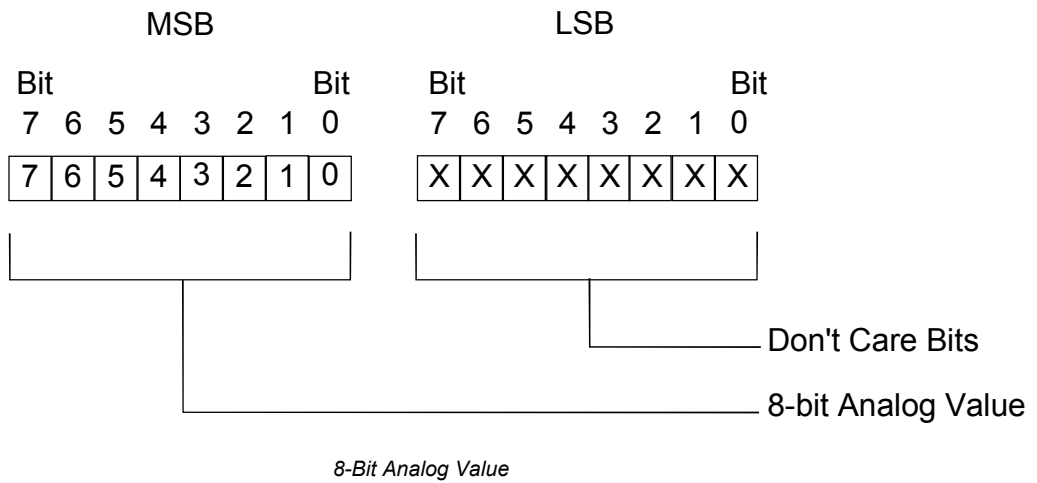

*All analog values are scaled to 12-bit representation regardless of internal precision.

Analog Control Command (45, C5)

Function	Byte Count	Effects Address	Command Code	Message
READ:				
Analog Controls	03	01	45	Analog #
WRITE:				
MLE 1 Analog Controls	05	01	C5	Analog # and value Analog #, LSB, MSB
MLE 1 all 4 Mask Edge Controls **	0B	01	C5	7F, top (LSB, MSB), Bottom (LSB, MSB), Left (LSB, MSB), Right (LSB, MSB)

Analog Control Numbers

Control #	Control Name
00	Fader Knob
0A	CLIP
0B	GAIN
0C**	MASK TOP
0D**	MASK LEFT
0E**	MASK RIGHT
0F**	MASK BOTTOM
18, (14)	MATTE FILL –HUE
19, (1F)	MATTE FILL – SAT
1A, (1B)	MATTE FILL - LUM
50**	TRANSPARENCY (0000 – 0FFF, 0000 = opaque, 0FFF = transparent)
7F**	MASK – TOP – BOTTOM – LEFT – RIGHT Used to decrease message traffic.

**Ross Video custom extension to GVG 100 protocol. Write Byte Count varies according to control number. Read Byte Count is 3.

Push-button / Lamp Control Command (46/47, C6/C7)

The read command is used by the editor to determine the status of a push-button and its associated lamp or LED. The keyer will, in turn, respond with the appropriate form of the write command, indicating either the “on” or “off” state of the specified push-button / lamp (PB/L).

The write command is used to turn the designated PB/L “on” or “off”. Use of an invalid PB/L number within a write command will cause the keyer to ignore the command.

Note

Commands 46 and 47 are identical. If an invalid PB/L number is specified in the read command, the reply will indicate an OFF status for a fictitious PB/L 00(H)

Push-button / Lamp Control Command (46/47, C6/C7)

Function	Byte Count	Effects Address	Command Code	Message
READ:				
Keyer PB/L	03	01	46/47	PB/L number
WRITE:				
Keyer PB/L On	03	01	C6	PB/L number
Keyer PB/L Off	03	01	C7	PB/L number

The Push-button / Lamp control command has limitations due the functional differences inherent in two types of push buttons on control panels; mutually exclusive and alternate-action. Mutually exclusive push-buttons are interlocked so that only one push-button in a group can be selected at a time; selecting one cancels any others in the group. In such groups, the C6 (write on) command will turn off the currently lighted button when another button is selected, but there is no action taken if the C7 (write off) command is sent to turn off the currently lighted button. Keyer logic requires that one button must always be selected.

The alternate-action type of push-button changes state each time the button is pressed, turning off on the first time it is selected, off the second time, on again the third, and so on. In the alternate-action groups, the Push-button / Lamp control command must select the correct “next state” – on or off – of the push-button or there will be no change to the status of the push-button.

Push-button / Lamp (PB/L) Number

Push-button Number	Description
0B	AUTO TRANS
0F	KEY auto transition
1B	BOX MASK Invert (GVG 200 extension)
1F	FADE TO BLACK (cut to/from black)
44	KEY INVERT
45	KEY MASK (box mask on/off)
46	KEY MATTE FILL
47	KEY VIDEO FILL
48	BKGD select
49	Transition includes KEY
4A	CUT (write only)
4C	KEY SELF – Self Key (acts like an interlocked button)
4D	KEY AUTO - Auto Select key (acts like an interlocked button)
52	KEY ON
54	V FADE TO BLACK
60	MASK FORCE
62	KEY ADDITIVE

When issued together with “Push button on”(C6) command or “Push button select”(FB) command, 0F, 0C, and 52 will invoke the corresponding transition. No transition starts if they are issued together with “Push button off”(C7) command.

When issued together with “Read back”(46/47) commands, 0F will return a message showing whether its corresponding auto trans is going on. 52 will not return a message.

Transition Mode Command (4A, CA)

The editor uses the read command to determine the transition mode of the keyer. The response from the keyer will be in the form of the write command, the message byte having the format shown below. A write command from the editor sets the keyer transition mode. The format of the message byte is shown below.

Note

The CDK-111A-Lite will treat bits 0 and 1 as interchangeable since it only has one keyer.

The CDK-111A-Lite will ignore bit 2 since it lacks mix capability.

Transition Mode Command (4A, CA)

Function	Byte Count	Effects Address	Command Code	Message
READ:				
Next Transition	02	01	4A	None
WRITE:				
Next Transition	03	01	CA	mode byte

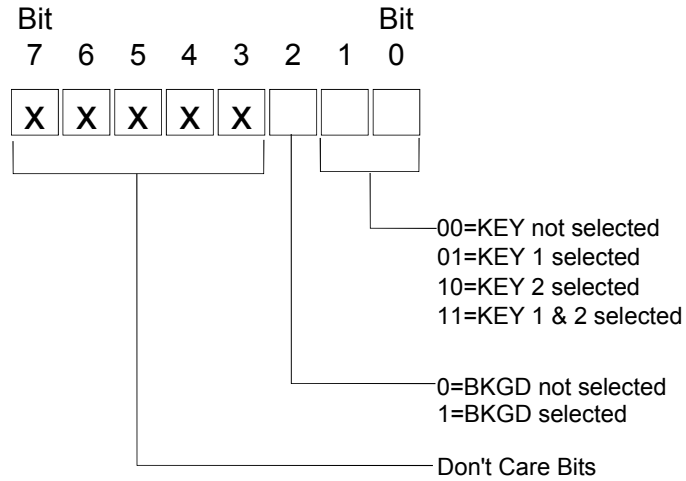

Transition Mode Byte Format

Auto Transition Rate Command (AC/7D, CC/FD)

The editor uses the read command to determine the currently set auto transition rate for the type of transition specified in the command. The response from the keyer will be in the form of the write command, the message bytes having the formats shown in the figure on the next page.

A write command from the editor sets the auto transition frame rate. The rate is specified in three message bytes; their formats are shown below. Note that the write command updates the appropriate auto transition rate display and may or may not initiate the transition. Each digit of the frame rate is expressed in binary coded decimal (BCD). The rate message bytes formats are shown below.

Rate Byte 1 – contains a transition start control bit and the most significant digit (hundreds digit) of the frame rate.

Rate Bytes 2 and 3 – Rate byte 2 contains the next most significant digit (tens digit) of the frame rate. Rate byte 3 contains the least significant digit (units digit) of the frame rate.

Note

The CDK-111A-Lite will treat bits 0 and 1 as interchangeable since it only has one keyer.

The CDK-111A-Lite will ignore bit 2 since it lacks mix capability.

Auto Transition Rate Command (AC/7D, CC/FD)

Function	Byte Count	Effects Address	Command Code	Message
READ:				
AUTO Transition Rate	02	01	4C	None
FADE Transition Rate	02	01	7D	None
VFTB Transition Rate	02	01	7C	None
WRITE				
AUTO Transition Rate	05	01	CC	Rate bytes 1, 2, 3
FADE Transition Rate	05	01	FD	Rate bytes 1, 2, 3
SET				
VFTB Transition Rate	05	01	FC	Rate bytes 1, 2, 3

Rate1=Transition control bits and most significant digit of rate

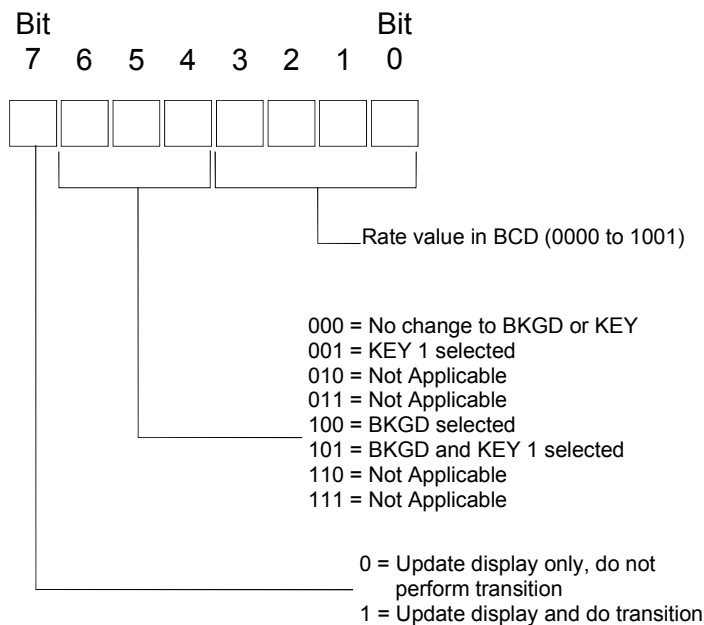

Message Rate Format – Rate Byte #1

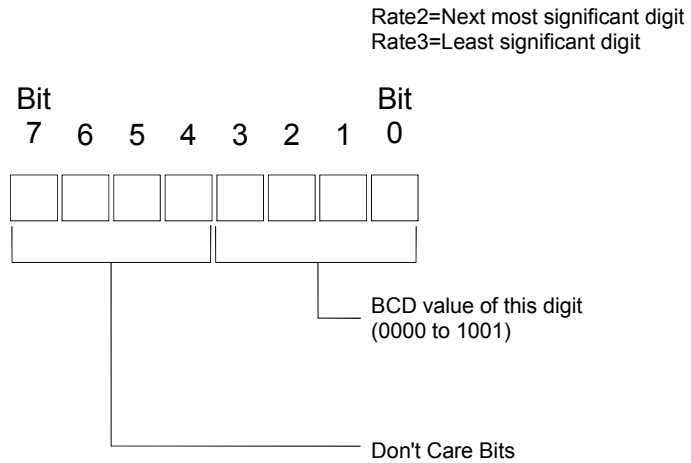

Message Rate Format - Rate Byte #2, #3

All Stop Command (-, F2)

There is no read command. The write command sets the keyer to a known state; the following occurs:

1. Any ongoing transition is stopped.
2. The transition fader is set to a limit.
3. Any key is removed from the program output.
4. Any current fade to black is removed (up from black).
5. The next transition is set to KEY only on the CDK-111A-Lite.

Note

The message byte is ignored. It is there to maintain consistency with Model 100 protocol, which placed it there to be consistent with Model 300 protocol.

All Stop Command (-, F2)

Function	Byte Count	Effects Address	Command Code	Message
WRITE:				
All Stop	03	01	F2	D0

Push-button Select Command (-, FB)

There is no read command. The write command from the editor performs a press of the push-button in the same manner that an operator would press a button on a control panel. This is different from the PB/L command in that it doesn't require a prediction as to whether the control will be turned on or turned off.

This command is generally used to start an auto transition.

Transition Select Command (-, FB)

Function	Byte Count	Effects Address	Command Code	Message
WRITE:				
Push-button Select	03	01	FB	Push-button Number

Push Button Descriptions

Push-button Number	Description
0B	AUTO TRANS
0F	KEY auto transition
1B	BOX MASK Invert (GVG 200 extension)
1F	FADE TO BLACK
44	KEY INVERT
45	KEY MASK (box mask on/off)
46	KEY MATTE FILL
47	KEY VIDEO FILL
48	BKGD select
49	KEY select
4A	KEY CUT (write only)
4C	KEY SELF – Self Key (acts like an interlocked button)
4D	KEY AUTO - Auto Select key (acts like an interlocked button)
52	KEY CUT
54	V FADE TO BLACK
60	MASK FORCE
62	KEY ADDITIVE

When issued together with “Push button on”(C6) command or “Push button select”(FB) command, 0F, 0C, and 52 will invoke the corresponding transition. No transition starts if they are issued together with “Push button off”(C7) command.

When issued together with “Read back”(46/47) commands, 0F will return a message showing whether its corresponding auto trans is going on. 52 will not return a message.

Software Version Command (6C, EC)

The editor uses the read form of this command to determine the keyer software version. The response from the keyer will be in the form of the write command. Note that the write command is shown (see below) for explanation purposes only. It is not intended to be sent by the editor to the keyer.

Software Version Command (6C, EC)

Function	Byte Count	Effects Address	Command Code	Message
READ:				
Software Version	02	00	6C	None
WRITE:				
Software Version	0B	00	EC	9 data bytes (see below)

Sample of a software version number (9 byte string):

“V 1 2 . 1 4 b b b”

(Most significant digit d0 = V b = D8 least significant digit)

Where:

- ‘V’ just stands for version
- ‘12’ is the major release number
- ‘.’ is an ASCII period acting as a separator
- ‘14’ is the minor release number
- ‘B’ is an ASCII space padding out the rest of the message (this may be filled with data in future releases).

Card Status Command (73, 74)

The editor uses the read command to determine the current status of the key. The response from the keyer will be in the form of the write command, the message byte having the formats shown in the figure below the table.

Note

The CDK-111A-Lite will treat bits 0 and 1 as interchangeable since it only has one keyer.

Note

The write command updates the appropriate key status display and may or may not change the key status.

The write command is shown (see below) for explanation purposes only. It is not intended to be sent by the editor to the keyer.

Card Status Command (73, 74)

Function	Byte Count	Effects Address	Command Code	Message
READ:	02	00	73	None
WRITE:	03	00	74	Card Status Byte

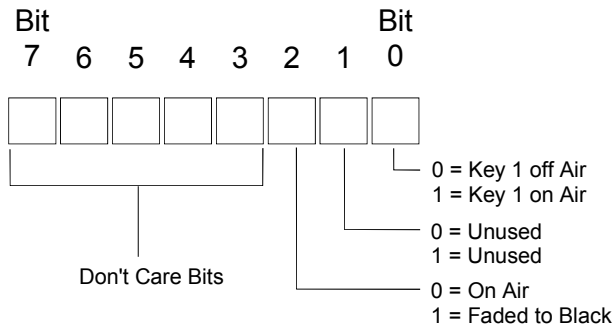

Card Status Byte Format

Error Status Command (71, 72)

The editor uses the read command to determine the current status of the BKGD and KEY video input signals. The response from the keyer will be in the form of the write command, the message byte having the formats shown in the figure below the table.

Note

The CDK-111A-Lite will treat bits 0 and 1 as interchangeable since it only has one keyer.

Note

The write command is shown (see below) for explanation purposes only. It is not intended to be sent by the editor to the keyer.

Error Status Command (71, 72)

Function	Byte Count	Effects Address	Command Code	Message
READ:	02	00	71	None
WRITE:	03	00	72	Error Status Byte

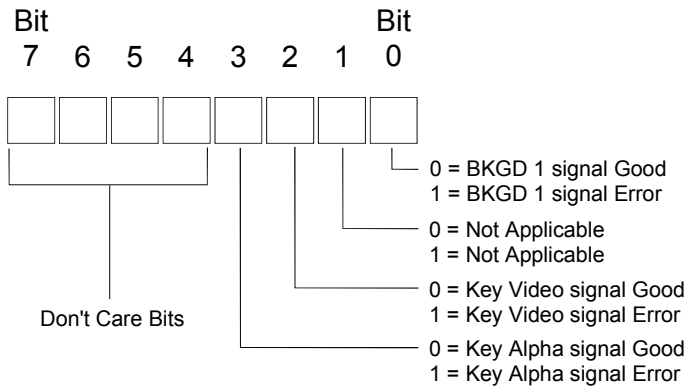

Error Status Byte Format

Additions to the GVG 100 Emulation Protocol

Extra Commands / Control Numbers:

Taken from GVG 200 extension to the protocol – analog control numbers.

- BOX MASK Invert push-button number.

Ross Video Custom Commands

- READ/WRITE Analog all 4 mask edges (Top-Bottom-Left-Right) (single command)
- Box Mask Force
- Transparency
- Card Status
- Error Status

Commands Not Implemented

- READ/WRITE Lamp Status
- WRITE Status Update Command
- READ/WRITE Field Mode Command
- Transfer Memory Register Command
- STORE/RECALL Memory Command

The above commands will be ignored. The above write commands will result in a command valid ACK being returned for compatibility reasons.

- READ/WRITE Key Memory Command

Other Differences

In the event of a communications error a GVG 100 becomes de-selected. The CDK-111A-Lite instead, remains selected and will search the receive buffer for the next combination of characters that can be interpreted as a valid command. A subsequent break character can be sent to flush the receive buffer and de-select the CDK-111A-Lite.

Note

The degree of command error checking used in the CDK-111A-Lite may vary from that for the GVG 100 resulting in some differences as to where the frame responds with Command accepted or Protocol Error.

GVG MASTER2100 Emulation Protocol

This section provides selected GVG MASTER2100 Protocol commands supported by the CDK-111A-Lite.

If your application requires further GVG MASTER2100 protocol command support, please contact Ross Video with this request.

Ross Video's use of the protocol deviates from the standards defined in the GVG Automation Interface Protocol Manual, (5.1 software release, Technical Reference 071011605, for the M-2100 Digital Master Control System, revised printing: July 2001,) in these respects:

- Subscription command class is not supported.
- Audio processing commands not supported, audio processor status requests get a return stating "Quiescent".
- The CDK-111A-Lite ignores commands it is not capable of performing, i.e. 4 keyer control, wipes.

Command Format

The following is a sample command using the MASTER2100 emulation protocol.

02 84 01 82 01 77 4F

Note

The spaces between characters in the sample command is for explanation/display purposes only.

The sample command fields and syntax are explained in the following table and sections.

Command Format Component Fields

Header Fields			Command Fields			Footer Field
Start transmission	Message byte length	Command Class	Data field byte length	ID Value	Data field	Checksum
02	84	01 up to 05	82	01	77	4F

Header Field Descriptions

02 = Start Transmission field, mandatory opening byte, in ASCII Hex.

84 = Message byte length, not including itself, the start transmission byte, or the Checksum byte(s), in ASCII Hex. All byte counts can be encoded as one or two bytes. If the most significant bit of the first byte is set, then the byte count consists of only one byte. This encoding allows up to 127 bytes to be represented with a single byte while up to 32,767 bytes with two bytes.

01 up to 05 = Command Class indicator:

01 A Command from the Control Panel to the CDK-111A-Lite.

02 A Query from the Control Panel asks how the CDK-111A-Lite is set for this command function.

- 03** A Status response from the CDK-111A-Lite in reply to a Query, can be either a statement of its particular command function parameters as requested, or 'command-initiated' and 'command-completed' responses as requested.
- 04** Acknowledge to a command, status response.
- 05** Not Acknowledge to a command, status response.

Data Field Descriptions

82 = Data field byte length, not including itself, including the data field byte length byte, the sub-command field byte, and the actual data field byte(s), in ASCII Hex. All byte counts can be encoded as one or two bytes. If the most significant bit of the first byte is set, then the byte count consists of only one byte. This encoding allows up to 127 bytes to be represented with a single byte while up to 32,767 bytes with two bytes.

01 = Sub-command field, the command-specific number, in Hex.

77 = A sample command-specific data field in Hex. The command-specific data fields and their binary parameters are defined in the command sections following this overview.

Footer Field Descriptions

4F = Single-byte sum of all fields between the message byte length and the last data field, inclusive, MSB (most significant byte) first. The sum of all message fields plus the checksum value should equal 0.

Command List

The following table lists the supported MASTER2100 protocol commands:

Command List

Function	Mnemonic	ID Value	Command	Query	Status
Next Transition	TX_NEXT	0x01	Yes	Yes	Yes
Start Transition	TX_START	0x02	Yes	No	Yes
Select Transition Type	TX_TYPE	0x03	Yes	Yes	Yes
Select Transition Rate	TX_RATE	0x04	Yes	Yes	Yes
Transition Status	TX_STAT	0x05	No	Yes	Yes
Take Crosspoint	XPT_TAKE	0x06	Yes	Yes	Yes
Break Away	BREAK_AWAY	0x07	Yes	Yes	Yes
Key Modifier	KEY_MOD	0x0A	Yes	Yes	Yes
Key Enable	KEY_ENABLE	0x0B	Yes	Yes	Yes
Key Status	KEY_STAT	0x0C	No	Yes	Yes
Automation Enable Status	AUTO_STAT	0x0D	No	Yes	Yes
Stop Ongoing transition	ALL_STOP	0x0E	Yes	No	Yes
System Status	SYSTEM_STAT	0x12	No	Yes	Yes
System Configuration	SYSTEM_CONFIG	0x13	No	Yes	Yes
Transition Status	TX_STAT2	0x15	No	Yes	Yes
Error Status for Previous	ERROR_STAT	0x20	No	Yes	Yes
Protocol / Version	PROTO_VER	0x21	No	Yes	Yes

Function: a description of the command's function on the CDK-111A-Lite.

Mnemonic: the (case-sensitive) command syntax.

ID Value: a Hex identifier number unique to each command.

Command: indicates whether the command can be in the form of a command (in the class indicator field) to the CDK-111A-Lite or not.

Query: indicates whether the command can be in the form of a query (in the class indicator field) to the CDK-111A-Lite or not.

Status: indicates whether the command can be in the form of a status response (in the class indicator field) from the CDK-111A-Lite

The command-specific data fields for the supported GVG MASTER2100 protocol commands are defined in the following section.

GVG MASTER2100 Emulation Commands

Following are the commands supported by the CDK-111A-Lite

Next Transition (0x01, TX_NEXT)

This command is for Keyer 1 only. If commands TX_NEXT and KEY_ENABLE are sent in the same field, the KEY_ENABLE command must be sent first.

Next Transition (0x01, TX_NEXT)

Function	Command Data Field
	Next Transition
COMMAND	1 byte
QUERY	
REPLY	1 byte

Next Transition byte values:

- 02 Key transition
- Bit 2-7 Reserved

Note: Either bit 0, bit 1, or both must be selected. 00 is unrecognized.

Start Transition (0x02, TX_START)

Start Transition (0x02, TX_START)

Function	Command Data Field
	Trigger Mod
COMMAND	1 byte
QUERY	
REPLY	1 byte

Trigger Mod byte values:

- 01 Start video.
- 02 Bit 1-7 Ignored/Reserved

Select Transition Type (0x03, TX_TYPE)

Select the Transition Type for the next transition. The CDK-111A-Lite does not support wipes. If a wipe transition is selected, the CDK will perform a fade. If a transition type has been configured as a custom transition, the transition will execute as a custom transition.

Select Transition Type (0x03, TX_TYPE)

Function	Command Data Field
	Transition
COMMAND	1 byte
QUERY	
REPLY	1 byte

Transition data byte values:

- 01 Take
- 02 Fade-Fade
- 03 Take-Fade
- 04 Mix
- 05 Fade-Take
- 06 Wipe (only does fade)

Select Transition Rate (0x04, TX_RATE)

Command information:

- Replies: returns the rate type and rate value for the next transition.
- If a new Transition Type is selected by the Automation system, any previously specified protocol rate will be overridden by the rate associated with the selected Transition Type. Therefore the automation system must first send the desired Transition Type, then send the Rate.
- If a Rate is selected, it is “remembered” as associated with the currently selected (non-Cut Transition Type. Whenever that Transition Type is again selected, the remembered Rate is recalled (Slow, Medium, Fast).
 - When automation selects a <rate type> = Slow, Medium, or Fast, it is remembered.
 - When automation selects a <rate type> = Rate and supplies a value, the value will not be remembered for the current Transition Type.

Select Transition Rate (0x04, TX_RATE)

Function	Command Data Fields	
	Rate type	Rate
COMMAND	1 byte	1-2 bytes
QUERY		
REPLY	1 byte	1-2 bytes

Rate type byte values:

- 00 Rate value to be used
- 01 Slow (60 frames)
- 02 Medium (25 frames)
- 03 Fast (10 frames)
- 04 No Rate (For replies only - No Rate currently selected)

Rate byte(s, 2 bytes max) 00 through 999 frames

Transition Status (0x05, TX_STAT)

Command information: Status of transition at the time this query was received.

Transition Status (0x05, TX_STAT)

Function	Command Data Fields		
	Transition Video Status	Transition Audio Status	Hold Off
QUERY			
REPLY	1 byte	4 bytes	1 byte

Transition Video Status byte values:

- 01 Quiescent
- 03 Transitional
- 04 Fading To Black
- 05 Fading From Black
- 06 In Black

Transition Audio Status byte value:

- 01 Quiescent - is the only value available for each of the 4 fields.

Hold On/Off Status byte value:

- 00 OFF- is the only value available for this field.

Take Crosspoint (0x06, XPT_TAKE)

Note: Hot cuts (XPT-Take, 0x06) are not allowed when a transition is in progress.

Take Crosspoint (0x06, XPT_TAKE)

Function	Command Data Fields		
	Bus Select	Crosspoint	Audio only
COMMAND	2 bytes	1 byte	1 byte
QUERY			
REPLY	2 bytes	1 byte	1 byte

Bus Select byte values ¹:

- 01 Program Bus
- 02 Preset Bus
- Bit 2-15 Ignored/Reserved

Crosspoint byte values:

- 00 No Change
- 01-FF Crosspoint number

Audio Only Crosspoint byte value:

- 00 No Change

1. One or more buses must be selected for the command format of this field. Only one bus may be selected for the query format of this field. No buses selected is an invalid condition.

Break Away (0x07, BREAK_AWAY)

This command breaks away (takes) audio from video, and clears any overs that may be selected. Audio functions are not supported.

Break Away (0x07, BREAK_AWAY)

Function	Command Data Fields			
	Break Away Type	Bus Select	Crosspoint	Audio Only crosspoint
COMMAND	1 byte	2 bytes	1 byte	1 byte
QUERY	1 byte	2 bytes		
REPLY	1 byte	2 bytes	1 byte	1 byte

Break Away Type byte values:

- 01 Video

Bus Select byte values ¹:

- 01 Program Bus
- 02 Preset Bus
- Bit 2-15 Reserved

Crosspoint byte values:

- 00 No Change
- 01-FF Crosspoint number

Audio Only Crosspoint byte values

- 00 No Change

1. One or more buses must be selected for the command format of this field. Only one bus may be selected for the query format of this field. No buses selected is an invalid condition.

Key Modifier (0x0A, KEY_MOD)

This command selects the characteristics for the requested key. The squeeze back field has no effect. The “Keyer Select” parameter selects keyer 1 only for modification.

Key Modifier (0x0A, KEY_MOD)

Function	Command Data Fields		
	Keyer Select	Key Modifier	Squeeze Back
COMMAND	1 byte	1 byte	1 byte
QUERY	1 byte		
REPLY	1 byte	1 byte	1 byte

Keyer Select byte value ¹

01 Keyer 1 select

Key Modifier bit settings

Bit 0 0 = Self
1 = External
Bit 1 0 = Matte
1 = Video
Bit 2-4 Ignored
Bit 5-7 Reserved

SqueezeBack Position byte values ²

00 No change

1. One keyer must be selected for the command format of this field. One keyer may be selected for the query format of this field. No keyers selected is an invalid condition.

2. Not yet implemented.

Key Enable (0x0B, KEY_ENABLE)

This command selects Keyer 1 to be on or off air after the next transition.

- Selecting a Keyer (bit=1) at the next transition will take an off-air key on-air, or leave an on-air key on-air. Setting (bit=0) has a similar, but complimentary effect.
- Selecting a Keyer (bit=1) for a currently off-air Keyer will cause that Key to be seen on the PST bus.

See comments in the TX_NEXT command notes concerning interaction with the KEY_ENABLE command.

Key Enable (0x0B, KEY_ENABLE)

Function	Command Data Field
	Keyer Select
COMMAND	1byte
QUERY	
REPLY	1 byte

Keyer Select byte values ¹

- 01 Keyer 1
- Bit 2-7 Ignored/Reserved

1. One or more keyers must be selected for the command format of this field. Only one keyer may be selected for the query format of this field. No keyers selected is an invalid condition.

Key Status (0x0C, KEY_STAT)

This command indicates that status for Keyer 1 if not physically present will be reported as off-air. Use the System Status and System Configuration commands to obtain more information.

Key Status (0x0C, KEY_STAT)

Function	Command Data Field
	Keyer Status
QUERY	
REPLY	1 byte

Keyer Status bit settings

- Bit 0 Keyer 1 (0 = Off air, 1 = On air)
- Bit 1-7 Ignored/ Reserved

Automation Enable Status (0x0D, AUTO_STAT)

This command send an Enabled reply to a Status query. On the CDK-111A-Lite, the Automation interface cannot be disabled.

Automation Enable Status (0x0D, AUTO_STAT)

Function	Command Data Field
	Keyer Status
QUERY	
REPLY	1 byte

Status byte value

- 01 Enabled

Stop Ongoing Transition (ALL_STOP)

This command stops all on-going transitions and resets the system to a known state.

Stop Ongoing Transition (ALL_STOP)

Function	Command Data Field
	All-Stop Options
COMMAND	1 byte

All-Stop Options bit settings

- Bit 0 Transitions are cut to final state
- Bit 1 Reserved
- Bit 2 The transition mode is set to background
- Bit 3 All keys are removed
- Bit 4 Change PGM and all AP's to crosspoint #1 (normally black)
- Bit 5-7 Reserved

System Status (0x12, SYSTEM_STAT)

This reply returns only values of 0, indicating an “okay” condition. This is done so the entire status byte can be tested against zero to determine if anything is *not* functioning.

System Status (0x12, SYSTEM_STAT)

Function	Command Data Field
	System Status
QUERY	
REPLY	2 bytes

System Status byte value

00 OK.

System Configuration (0x13, SYSTEM_CONFIG)

This reply returns only values of 0, indicating an “okay” condition. This is done so the entire configuration byte can be tested against zero to determine if anything is *not* functioning.

System Configuration (0x13, SYSTEM_CONFIG)

Function	Command Data Field
	Configuration
QUERY	
REPLY	3 bytes

Configuration byte value

00 OK.

Transition Status (0x15, TX_STAT2)

This command reply gives the status of transition at the time this query was received.

Transition Status (0x15, TX_STAT2)

Function	Command Data Fields			
	Transition Video Status	Bus Select	Crosspoint	Audio Only crosspoint
QUERY				
REPLY	1 byte	2 bytes	1 byte	1 byte

Transition Video Status byte values

- 01 Quiescent
- 03 Transitional
- 04 Fading To Black
- 05 Fading From Black
- 06 In Black

Keyer 1 Summary Status byte value

- 01 Quiescent
- 03 Transitional
- 04 Fading To Black
- 05 Fading From Black
- 06 In Black

Transition Audio Status byte value

- 01 Quiescent

Hold On/Off Status byte value

- 00 OFF

Error Status for Previous (0x20, ERROR_STAT)

This query should only be issued after a NAK has been received from the CDK-111A-Lite or the CDK-111A-Lite did not perform the desired action. Upon receipt of a message, the CDK-111A-Lite will perform a cursory check to validate it and may uncover other errors when the command is actually processed. If no errors have occurred since the last message was received by the CDK-111A-Lite, an error code of NO_ERR will be returned.

Error Status for Previous (0x20, ERROR_STAT)

Function	Response Data Fields					
	Error Code	Command Class	Sub-Command	Byte Position	Offending Data	Argument Number
QUERY						
REPLY	1 byte	1 byte	1 byte	2 bytes	4 bytes	1 byte

Error Code byte values

00	No_err	No errors have occurred since the last message was received.
01	Checksum_err	The checksum computed by the CDK-111A-Lite did not match the checksum in the message.
02	Command_err	Invalid or unrecognized Command-Class/ Sub-Command combination.
03	Bitfield_err	Invalid combination of bits selected in a data field.
04	Selection_err	Invalid selection in data field.
05	Range_err	Number in data field is out of range.
06	Feature_err	Requested feature is not implemented or not available.
07	Install_err	Requested feature is not installed.
08	Internal_err	Internal processing error.
09	Auto_disabled	Automation interface currently disabled.
10	Other_err	Other unexpected error (not fitting into any of the categories listed above).

Command Class byte value

Byte code found in the Command Class position of the message. This field will be zero for the No_Err and Checksum_Err error codes.

Sub-Command byte value

Byte code found in the Sub-Command position of the message. This field will be zero for the No_err and Checksum_err error codes.

Byte Position byte value

Approximate byte position in the message where the error was found (starting with the first byte after the STX and overall message byte count). This field will be zero for the No_err error code.

Offending Data byte value

Data that was found to be in error. If the data corresponding to the Command Class and Sub-Command is less than four bytes (as defined in the protocol), the data will be put in the least significant bytes of the 4-byte data field. This field will be zero for the No_err error code. For a Checksum_err, the data field will contain the checksum calculated by the CDK-111A-Lite.

Argument Number byte value

Argument or field number where the offending data was found.

Protocol / Version (0x21, PROTO_VER)

This query is provided so the controller of the M-2100 can inform the tributary which version of the M-2100 protocol is being used. The M-2100 (tributary) will respond with the version of the protocol that it is using. Incompatible versions between the controller and tributary may yield inconsistent results. The major/minor version is typically expressed in combination such as 2.1, where “2” is the major version and “1” is the minor version.

The major number is incremented if a change to the protocol or the applications which use the protocol is not backward compatible and will break the operation of

either end of the communications line. Anytime the major number is incremented, the minor number is reset to zero.

The minor number is incremented if a change to the protocol or the applications which use the protocol is backward compatible and will not break the operation of either end of the communications line.

Protocol / Version (0x21, PROTO_VER)

Function	Command Data Fields	
	Major	Minor
QUERY		
REPLY	1 byte	1 byte

Major byte value

03 The query format of PROTO_VER, the major field indicates the major protocol version that the controller is using.

In the reply format, the field indicates the major protocol version that the tributary is using.

Minor byte value

00 In the query format of PROTO_VER, the minor field indicates the minor protocol version that the controller is using.

In the reply format, the field indicates the minor protocol version that the tributary is using.

Appendix B. Software Upgrades

In This Appendix

This appendix provides instructions for upgrading the CDK-111A-Lite software. The following topics are discussed:

- Software Upgrade
- Replacing the CPU Boot Flash Chip

Software Upgrade

From time to time, it may be necessary to do an upgrade of the CDK-111A-Lite software. This is accomplished simply by replacing the **CPU Boot Flash Chip** (supplied by Ross Video) on the CDK-111A-Lite card itself. Please call **Ross Video Technical Support** or visit our website at www.rossvideo.com for additional information on the most current software version and CPU Boot Flash Chip availability.

Throughout this chapter, please heed the following cautionary note:

Caution

Static discharge can cause serious damage to sensitive semiconductor devices. Avoid handling the CDK-111A-Lite cards in high static environments such as carpeted areas and when synthetic fiber clothing is worn. Touch the rack frame to dissipate static charge before removing cards from the frame and exercise proper grounding precautions when working on the CDK-111A-Lite cards.

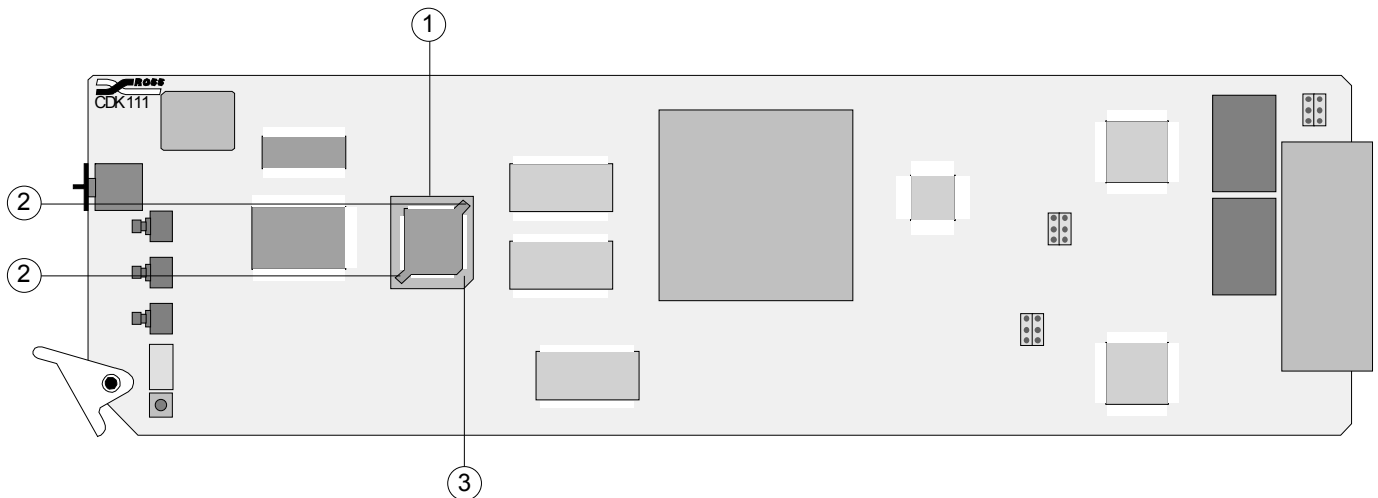

- | | | |
|------------------------------|---|-------------------|
| 1) CPU Boot Flash Chip (U10) | 2) Insertion Spaces for Extraction Tool | 3) Beveled Corner |
|------------------------------|---|-------------------|

Replacing the CPU Boot Flash Chip

Use the following steps to replace the **CPU Boot Flash Chip**:

1. Observe all static discharge precautions throughout the procedure.
2. Remove the front panel cover of the RossGear frame that houses the CDK-111A-Lite card.
3. Using the ejector lever on the bottom of the card, carefully remove the CDK-111A-Lite card from its slot and set it on a flat, static free surface, with the component side up as per the above diagram.

Caution

Card may be hot to the touch. Allow it time to cool and handle with care.

4. Locate the **CPU Boot Flash Chip**, which is identified as component **U10**. See the diagram above.
5. Insert the Chip Carrier Extraction Tool, which was supplied with your chip, into the two spaces provided in the IC socket (positions **2** on the diagram) and gently pry the chip upwards until it is freed from the contacts.

Caution

Be careful not to insert the Extraction Tool too far into the spaces, as it will become lodged on the base of the socket, and will bend or break the chip socket if too much pressure is applied.

6. Discard the used chip, as you will no longer require it.
7. Holding the new **CPU Boot Flash Chip** pin side down, locate the small indented dimple on the shorter beveled side of the chip. This circle must be lined up with the small arrow located within the IC socket. If you have placed the card right side up as per the diagram, the arrow will be pointing downward on the bottom edge of the socket base.
8. Carefully position the new chip over the IC socket, with the arrow and dimple aligned as stated above.

Note

If the chip is positioned properly, you will notice that the bottom right corner is beveled to match the shape of the socket (position **3** on the diagram), thus preventing improper insertion of the chip.

9. Insert the chip into the socket, pressing gently to fasten the chip into place.
10. Replace the CDK-111A-Lite card into the RossGear frame slot from which it was removed.
11. Replace the front panel cover of the gear frame.

This completes the procedure for replacing the CPU Flash Boot Chip and hence, upgrading your CDK-111A-Lite software.

Appendix C. Specifications

In This Appendix

This appendix provides technical specifications and connector pinout diagrams. In addition, comprehensive tables are provided that list supported baud rates and GPI input, tally output and serial communication parameters.

The following sections are provided:

- Technical Specifications
- General
- System Timing
- Feature Comparison Chart
- Analog Reference Input
- Video Inputs
- Video Outputs
- CDK-111A-Lite BNC Connectors
- CDK-111A-Lite BNC Settings
- Baud Rates
- Cable Assemblies
- I/O, Power, Delay Specifications
- GPI Inputs, Tally Outputs and Serial Communication
- Jumper Locations
- Jumper Pinouts
- Jumper Configurations

Technical Specifications

General

The following is a list of general specifications pertaining to the CDK-111A-Lite:

- Built-in video test pattern generator (Flat-field black, PLL Pathological, EQ Pathological, Color bars 75%)
- Key Invert
- Rounding to 8-bit or 10-bit
- Dithering to 0, +/-3, +/-7 or +/-15 levels
- Fully digital 14-bit internal processing
- Clip to SMPTE Luminance range or allow Super-Black and/or Super-White levels (configured via menu)
- Card-edge menu system control
- Card-edge Key Trans button, Background Trans button and Fade To Black button
- RS-485 Remote control (GVG 100 Protocol)
- GPI and Tally BNCs (configured via menu)
- DCP-111 Control Panel (optional)
- SMPTE 269M Fault Reporting

System Timing

- All video inputs zero time relative to BKGD 1 input, auto timing will correct for inputs out of time by up to one full frame.
- The minimum delay through the keyer is 114 samples. This delay can be manually increased in single sample steps to a maximum of one full frame.
- Delays are adjustable between the start of the reference signal frame and the start of the video output frame.

Feature Comparison Chart

Feature	CDK-111A-Lite	CDK-111A-M
Video input channels	3	4
Number of keys on air	1	2
Preview Overlay menu display	No	Yes
BKGD crossfade	No	Yes
Frame synchronization on every input	Yes	Yes
External analog reference signal input	Yes	Yes
Adjustable delay from reference to output signal	Yes	Yes
Storage for multiple stills and animated logos	No	32MB
Fade to black	Yes	Yes
Program output with EDH insertion	Yes	Yes
Second program output with EDH insertion	Yes	Yes (1)
One preview output with EDH insertion	No	Yes (1)
Fail-safe relay BKGD1 to PGM Out 1 on power failure	Yes	Yes
Accommodates SMPTE 259M-C	Yes	Yes
USB port for image download	No	Yes
Full transition control with 0-999 frame control	Yes	Yes
Clip, gain, matte fill, and box mask controls	Yes	Yes
Control via GPI, unbalanced full duplex RS-485 or 0-12V RS-232 compatible interface, on-screen configuration menu, control panel, and card-edge pushbuttons	Yes	Yes
Supports 525-line (NTSC) and 625-line (PAL) formats	Yes	Yes
Serial interface	Yes	Yes
5 year warranty	Yes	Yes

1) Configured via the menu, if desired

Analog Reference Input

- Accept a black analog reference from the DFR-8110A-C frame.
- NTSC or PAL automatic detection.
- On-board Phase Lock Loop maintains a stable display if the analog reference is lost.

Video Inputs

- Three video inputs with independent frame synchronizers.
- Compliant with SMPTE 259M-C Serial 4:2:2 digital video signaling.
- Compliant with SMPTE Recommended Practice RP 168-1993, Definition of Vertical Interval Switching Point for Synchronous Video Switching. Will compensate for switching source signals with a phase offset up to 32 us (860 video samples).
- NTSC Vertical blanking interval may end at the start of any of the lines 10 (273) through 20 (283).
- Automatic cable equalization to 75 meters.

Video Outputs

- Two video outputs.
- Compliant with SMPTE 259M-C Serial 4:2:2 digital video signaling.
- NTSC vertical blanking interval ends on the start of line 20 (283), regardless of the video input signal timings.
- EDH insertion on both outputs.
- Other ancillary data selected from BKGD1 or BKGD2 input will pass through untouched.

CDK-111A-Lite BNC Connectors

The CDK-111A-Lite has nine (9) BNC connectors on the rear of each module, as shown below:

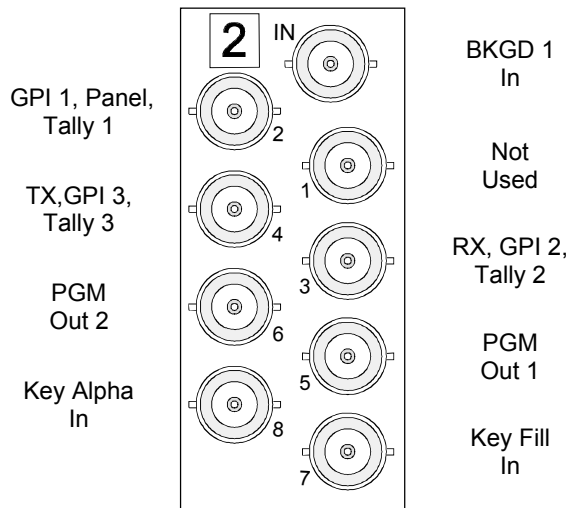

CDK-111A-Lite Connector Assignments

CDK-111A-Lite BNC Settings

Connector	Use
IN	BKGD 1 In – any video source, used as card reference
1	Not Used
2	GPI 1 or Panel or Tally 1 – (configurable via menu and jumper setting)
3	RX or GPI 2 or Tally 2 – (configurable via menu)
4	TX or GPI 3 or Tally 3 – (configurable via menu)
5	PGM Out 1
6	PGM Out 2
7	Key Fill In
8	Key Alpha In

Baud Rates

The following standard baud rate is supported:

Standard Baud Rate	CDK-111A-Lite Baud Rate	Deviation Error
19,200	19,231	+0.16%

Cable Assemblies

PC Interface Cable Assembly

Part number: 1111C-302

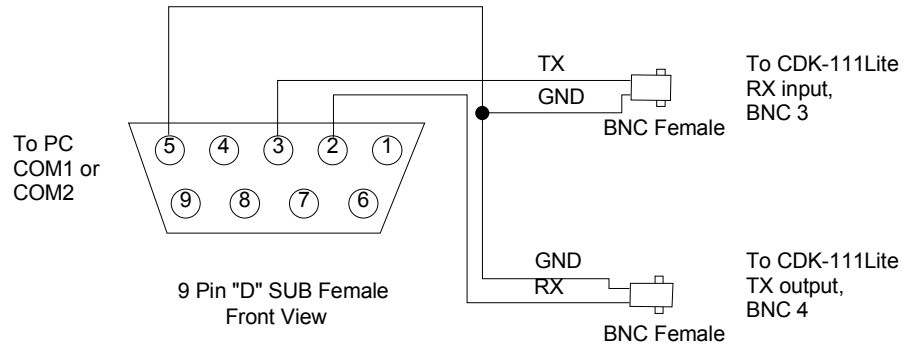

From DB9 Pin #	To BNC #	Conductor Type
2	4	Center
3	3	Center
5	3	Outer (GND)
5	4	Outer (GND)

I/O, Power, Delay Specifications

Technical Specifications		
Power Consumption	6.7V Power Rail	9.6watts
Serial Digital Video Input	Return Loss	15 dB
	BKGD1 Equalization	75 m
	BKGD2 Equalization	75 m
	Key Video Equalization	75m
	Key Alpha Equalization	75 m
Serial Digital Video Outputs	Return Loss	15 dB
	Signal Amplitude	700 mV
	Signal Overshoot	< 50 mV
	Signal Undershoot	< 50 mV
	Signal Rise Time	645 ps
	Jitter	851 ps
System Delay	Minimum delay is 4.19 us	to one full frame
DCP-111 Interface	Maximum cable length	100 m
RS422/485 Serial Interface	Rx/Tx Maximum cable length	300 m

GPI Inputs, Tally Outputs and Serial Communication

BNC #	Function	Description
BNC 2	GPI Input #1	0 – 5V TTL compatible input with 4.7K pull-up
	Remote Control	0 – 6.7V Proprietary serial communication protocol
	Tally Output #1	Open collector transistor sinking 100mA to BNC 2 GND shield. With 4.7K pull-up to +5V
BNC 3	GPI Input #2	0 – 5V TTL compatible input with 100K pull-up
	RX/TX	0 – 5V Single-ended RS-485 transceiver buffer, ¼ unit load
	Tally Output #2	0 – 5V TTL compatible output. Source/Sink 4 mA
BNC 4	GPI Input #3	0 – 5V TTL compatible input with 100K pull-up
	RX/TX	0 – 5V Single-ended RS-485 transceiver buffer, ¼ unit load
	Tally Output #3	0 – 5V TTL compatible output. Source/Sink 4 mA

Jumper Locations

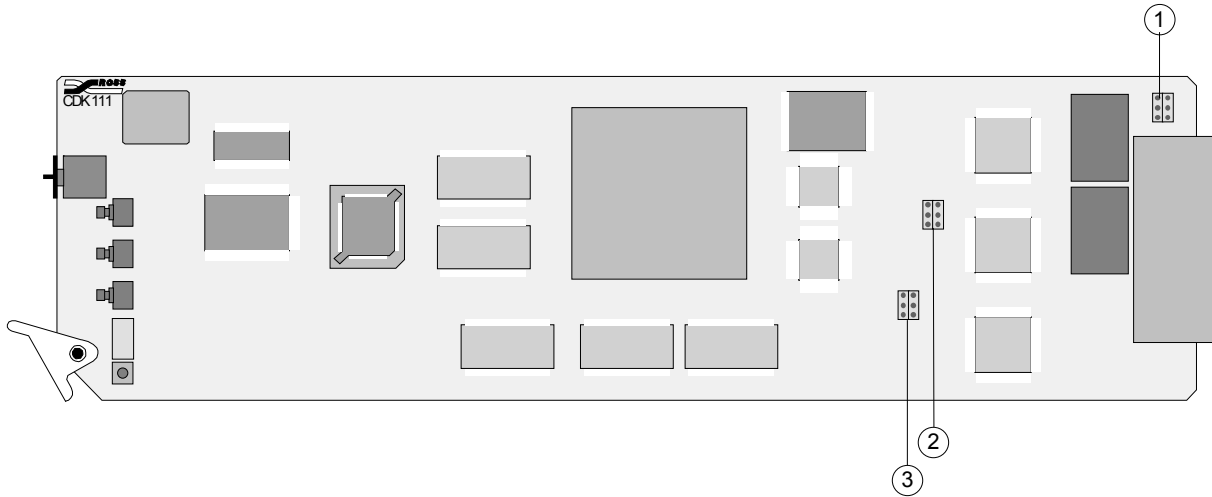

- | |
|---|
| <p>1) Rx Termination Jumper Block and Download Connector (J1)
 2) EDH Insertion Jumper Block (J5)
 3) GPI, Panel, Tally Jumper Block (J6)</p> |
|---|

Jumper Pinouts

Each jumper block (**J1**, **J5**, **J6**) has the same pinout configuration.

Pin Numbers, as viewed from component side of card

1	2
3	4
5	6

Jumper Configurations

RX Termination Jumper Block and Download Connector (J1)

Pins 1, 3, and 5 of **J1** configure the terminator resistor on BNC 4. BNC 4 is used normally as the RS422/RS485 Tx output and must not have a terminator resistor installed.

Pins 2, 4, and 6 of **J1** configure the terminator resistor on BNC 3 when that BNC is used as an RX input connector. BNC 3 is used normally as the RS422/RS485 Rx input. When several CDK-111A-Lites have this BNC connected in parallel, the last CDK must have the 120 Ohm terminator installed. All other CDK-111A-Lite cards in the chain must have the terminator removed. If this Rx input is driven from an RS232 serial port, then the 120 Ohm terminator must be removed on all CDKs.

This jumper block can also be used as a connector to serially transfer images and animation between the card and a PC, using the Serial Download Cable.

BNC 4 (Tx) RS422/RS485 Jumper Configuration

- Bridging pins 3 and 5 removes the 120 Ohm terminator on BNC 4 (Tx) output for *any position* card use.

BNC 3 (Rx) RS422/RS485 Jumper Configuration

- Bridging pins 2 and 4 installs a 120 Ohm terminator on the Rx (BNC 3) input for *single* card or *last* card use.
- Bridging pins 4 and 6 removes the 120 Ohm terminator on the Rx (BNC 3) input for *multiple* but *non-last* card use.

EDH Insertion Jumper Block (J5)

This jumper block is used to insert the EDH information into the PGM and/or PV video stream.

- Bridging pins 2 and 4 disable EDH insertion on the PGM and PV video outputs.
- Bridging pins 4 and 6 enable EDH insertion on the PGM and PV video outputs.

This jumper block can also be used to enable or disable STMPE 269M Fault Reporting.

- Bridging pins 3 and 5 enable STMPE 269M Fault Reporting.
- Bridging pins 1 and 3 disable STMPE 269M Fault Reporting.

GPI, Panel, Tally Jumper Block (J6)

This jumper block is used in conjunction with the menu (software) to define the status of BNC 2 – whether it is used as an input for a GPI, an input/output for a Control Panel, or as a Tally output.

- Bridging pins 1 and 2 configures the BNC 2 to be used as a GPI input.
- Bridging pins 3 and 4 configures the BNC 2 to be used with the DCP111 Remote Control Panel unit.
- Bridging pins 5 and 6 configures the BNC 2 to be used as a Tally output.



Caution — Only one bridge may be installed on the jumper block **J6**. Installing more than one bridge may cause permanent damage to the CDK-111A-Lite card. Please note that contrary to the other jumper blocks, the single bridge on **J6** must be installed horizontally to short circuit either pins 1 and 2, or pins 3 and 4, or pins 5 and 6.

Important

The configuration of this jumper blocks defines the function of the BNC 2 connector. The desired operation must also be setup with the CDK-111A-Lite on-screen menu and must match the configuration bridge installed on **J6**. See Chapter 2, “**Installation and Setup**” for more details.

Index

1

12-Bit Analog Value..... 4-13

8

8-Bit Analog Value..... 4-13

A

Accessing the menu system..... 2-9

A-D abbreviation..... 1-5

Address

byte..... 4-5

editor select..... 4-5

poll..... 4-5

select..... 4-5

All Stop Command..... 4-19

Analog Control

command..... 4-13

numbers..... 4-15

Analog reference specifications..... 6-3

Auto

detect, reference menu option..... 3-14

trans rate..... 3-11

trans rate menu item..... 3-11

Transition Rate Command..... 4-17

B

Baud Rates..... 6-6

BKGD abbreviation..... 1-5

Block diagram, CDK-111A-Lite..... 1-8

Block, command/message..... 4-6

BNC

2, configuration..... 2-15

2, configuration menu item..... 3-16

3, configuration..... 2-16

3, configuration menu item..... 3-17

4, configuration..... 2-16

4, configuration menu item..... 3-17

connectors..... 2-5

Listings menu..... 3-18

setup menu information..... 3-18

BNC IN reference menu option..... 3-14

Board

address..... 2-18

address, menu item..... 3-15

CDK-111A-Lite..... 1-4

ID..... 4-5

ID Switch..... 2-4

Box Mask

menu item..... 3-12

positioning menu..... 3-13

Break character..... 4-5

Button, menu..... 3-6

Byte

Command code..... 4-7

Count Byte..... 4-7

Editor Select Address..... 4-5

Effects address..... 4-7

Message..... 4-9

Write command, format of second..... 4-8

C

Cable

communications..... 2-6

connections..... 2-6

PC Interface, specifications..... 6-6

Cable Assembly, CDK-111A-Lite to a PC Interface 6-6

Card

Address Configuration..... 2-17

CDK-111A-Lite..... 1-4

delay, menu item..... 3-14

edge controls..... 2-9, 3-2

Installation and Setup..... 2-14

setup menu..... 3-16

Status Command..... 4-22

type..... 2-14

type, menu item..... 3-16

CDK-111A-Lite

block diagrams..... 1-8

cabling multiple..... 2-7

cabling single..... 2-6, 2-7

connector diagram..... 6-4

connectors..... 4-3

overview..... 1-6

serial interface, overview..... 4-2

technical specifications..... 6-2

CDK-111A-Lite, block diagram..... 1-8

Character, break..... 4-5

Chart, feature comparison..... 1-7

Chip

carrier extraction tool..... 5-3

CPU Boot Flash..... 5-2

replacing the CPU Boot Flash..... 5-2

Clip, Key1, menu item..... 3-11

Clipping, menu item	3-15
Column	
item	3-9
value	3-9
Command	
All Stop	4-19
Analog control	4-13
Auto transition rate	4-17
Card Status	4-22
code byte	4-7
Crosspoint	4-12
Error Status	4-23
Extra, and control numbers	4-24
Push-button select	4-19
Push-button/Lamp Control	4-15
Software version	4-21
Transition mode	4-17
Transition select	4-19
Command/message block structure	4-5, 4-6
Commands	
not implemented, GVG 100	4-24
Read	4-7
Write	4-7
Communication cables	2-6
Comparison chart, features	1-7
Connection, cable	2-6
Connector pinouts, editor	4-3
Connectors	
BNC	2-5
CDK-111A-Lite	2-5
Control Panel	
Installation	2-11
Control Panel, DCP-111 (Optional)	2-11, 3-5
Controls, Card edge	2-9
Conventions, documentation	1-3
CPU Boot Flash Chip	
replacing	5-2
software upgrade	5-2
Crosspoint Command	4-12
Current Reference Source, menu item	3-14
Cursor	3-9
Customer service	1-9, vi
D	
DA abbreviation	1-5
D-A abbreviation	1-5
DCP-111	
optional control panel	2-11, 3-5
Delays	
alpha, menu item	3-14
BKGD 1, menu item	3-14
BKGD 2, menu item	3-14
key, menu item	3-14
Deviations from GVG 100 Protocol	4-24

Diagnostics	
Alpha video, menu item	3-15
BKGD 1 video, menu item	3-14
BKGD 2 video, menu item	3-14
Key video, menu item	3-14
menu	3-14
Display	
test pattern	2-15
test pattern, menu item	3-16
Dithering, menu item	3-15
Documentation	
conventions	1-3
terms	1-4
DSK abbreviation	1-5
DVE abbreviation	1-5

E

Edge triggers, GPI	3-7
EDH abbreviation	1-5
EDH insertion jumper	6-9
EDH Insertion Jumper	2-4
Editor	
connector pinouts	4-3
interface state diagram	4-10
transmission standard	4-3
Effects address byte	4-7
Electronics frame	1-4
Error Status Command	4-23
External reference	
menu option	3-14
Extra Commands/Control Numbers	4-24

F

Facilities	
with less than 16 CDK-111A-Lites	2-17
with more than 16 CDK-111A-Lites	2-18
Factory Default	2-16
Factory Default, menu item	3-17
Fade to Black	3-6
Feature comparison chart	1-7
Fill, menu item	3-12
FPGA Version	2-14
FPGA Version, menu item	3-16
Frame, electronics	1-4
Freeze, (Un)freeze key + alpha, menu item	3-13
FTB trans rate menu item	3-11
Functions	
GPI	3-7
tally	3-8

G

Gain, Key1 menu item	3-11
Getting Started	2-2

GPI	
abbreviation	1-5
edge triggers	3-7
functions	3-7
Input.....	2-15, 2-16, 3-16, 3-17, 6-7
level states	3-7
level triggers	3-7
panel, tally jumper	6-9
Panel, Tally Jumper	2-4, 3-5
setup, menu	3-17
triggers	3-7
GPI #1 Trigger, menu item	3-17
GPI #1, menu item.....	3-17
GPI #2 Trigger, menu item	3-17
GPI #2, menu item.....	3-17
GPI #3 Trigger, menu item	3-17
GPI #3, menu item.....	3-17
GVG 100	
panel	4-2
protocol commands.....	4-11
protocol deviations	4-24
protocol introduction	4-2
GVG MASTER2100	
command descriptions	4-28
command format.....	4-25
command list	4-27
protocol commands.....	4-25
H	
Hardware installation.....	2-1
Help, in menus.....	3-9
Hue, menu item	3-13
I	
I/O for the control panel	2-15, 3-16
IC Socket	5-3
ID	
abbreviation	1-5
board.....	4-5
Input/Output Delays menu.....	3-14
Inputs	
video, specifications	6-4
Installation	
and Setup, CDK-111A-Lite Card	2-14
Control Panel.....	2-11
hardware	2-1
Interface Cable Assembly, CDK-111A-Lite to a PC	6-6
Introduction	1-1
Item Column, menu	3-9
J	
J1, RX termination jumper, download connector	2-4, 6-8
J5, EDH insertion jumper	6-9
J5, EDH Insertion Jumper.....	2-4
J5, STMPE 269M Fault Reporting enable/disable jumper	6-9
J6, GPI, panel, tally jumper.....	6-9
J6, GPI, Panel, Tally jumper	3-5
J6, GPI, Panel, Tally Jumper.....	2-4
Jumper Locations	6-8
Jumper pinouts	6-8
Jumper settings	
RS 232.....	2-7
RS 422/485.....	2-6
RS 485 for multiple cards	2-7
K	
Key	
alpha mode, menu item	3-12
invert , menu item	3-12
type, menu item.....	3-12
Key1	
clip, menu item.....	3-11
gain, menu item.....	3-11
setup menu	3-11
source, menu item	3-11
status, menu item	3-11
Keyer Type.....	2-15
Keyer Type, menu item.....	3-16
L	
LED functions.....	3-4
Level triggers, GPI.....	3-7
Light Emitting Diode functions	3-4
Linear key	3-11
Luminance, menu item.....	3-13
M	
Make key linear, menu item.....	3-11
Mask	
box	3-12
invert, menu item	3-13
Mask position	
bottom edge, menu item.....	3-13
left edge, menu item.....	3-13
right edge, menu item.....	3-13
top edge, menu item	3-13
Matte	3-12
Menu	
1, Runtime Parameters	3-11
2, Key1 Setup.....	3-11
4, Box Mask Positioning.....	3-13
5, Matte Selection	3-13
9, Input/Output Delays.....	3-14
A, Diagnostics.....	3-14
button	3-6
C, Secondary Card Setup	3-15

cursor	3-9
D, Card Setup	3-5, 3-16
E, Tally/GPI setup	3-17
F, BNC Listings	3-18
number	3-9
output display selection	2-15
Selector	2-3, 3-2
system	3-9
system, accessing	2-9
title	3-9
titles	3-10
Menu Down button	2-3
Menu Down/Key button	3-2
Menu Select/FTB button	2-3, 3-3
Menus	
Navigation using the card edge buttons	2-10
Navigation using the control panel	2-13
Message bytes	4-9
Mode, key alpha	3-12
Module, CDK-111A-Lite	1-4

N

Navigating Menus Using the Card Edge Buttons	2-10
Navigating menus using the control panel	2-13
Number of menu	3-9

O

One Line Help in menus	3-9
Operation of CDK-111A-Lite	3-1
Operator, CDK-111A-Lite	1-4
Outputs	
video, specifications	6-4
Overview, CDK-111A-Lite	1-6

P

PC Interface Cable Specifications	6-6
PGM abbreviation	1-5
Pinouts, editor connector	4-3
Pinouts, jumpers	6-8
Poll Address	4-5
Product comparison charts	1-7
Protocol	2-15
elements	4-5
GVG 100	4-2
GVG 100 commands	4-11
GVG MASTER2100 commands	4-25
GVG100	3-16
introduction	4-1
MASTER2100	3-16
none used	3-16
PC SOFTWARE 19200	3-16
PC SOFTWARE 57600	3-16
Protocol, menu item	3-16
Push-button Select Command	4-19

Push-button/Lamp (PB/L) Number	4-15
Push-button/Lamp Control Command	4-15
PV abbreviation	1-5

R

Read Commands	4-7
Reference	
analog, from frame	6-3
Reference Source Select menu item	3-14
Reset Button	2-4
Rounding, menu item	3-15
RS 232 jumper settings	2-7
RS 422/485 jumper settings	2-6
RS 485 jumper settings for multiple cards	2-7
RU abbreviation	1-5
Runtime Parameters menu	3-11
RX Input	2-16, 3-17
RX termination jumper, download connector	2-4, 6-8

S

Saturation, menu item	3-13
SDI	
abbreviation	1-5
interface	1-4
Secondary Card Setup menu	3-15
Secondary Output (BNC 6)	2-15
Serial Communication	6-7
Serial Protocol	
GVG 100 commands	4-11
GVG MASTER2100 commands	4-25
introduction	4-1
Service, Customer	1-9, vi
Shaped key	3-12
Socket, IC	5-3
Software	
upgrading	5-1, 5-2
version	2-14
Version Command	4-21
version, menu item	3-16
Specifications	
general	6-2
GPI inputs	6-7
Serial communications	6-7
Tally outputs	6-7
technical	6-1, 6-2
Standalone keyer	3-16
Standard, Editor transmission	4-3
Static discharge	2-1, 5-2
Status of Key 1	3-11
STMPE 269M Fault Reporting enable/disable jumper	6-9
Support, technical	1-9, vi
SW1, Menu Selector	2-3, 3-2
SW3, Menu Down/Key button	2-3, 3-2
SW4, Menu select/FTB button	2-3, 3-3

SW5, Board ID Switch	2-4
SW6, Reset Button	2-4
Switch, trans rate toggle	3-6
System	
menu	3-9
timing	6-2
video	1-4

T

Tally	
functions	3-8
input	2-16, 3-17
level states	3-8
output	2-15, 2-16, 3-16, 3-17, 6-7
setup, menu	3-17
triggers	3-8
Tally #1 Trigger, menu item	3-18
Tally #1, menu item	3-17
Tally #2 Trigger, menu item	3-18
Tally #2, menu item	3-18
Tally #3 Trigger, menu item	3-18
Tally #3, menu item	3-18
Technical support	1-9, vi
Terms, documentation	1-4
Test Pattern Selection	2-15
Test Pattern, menu item	3-16
Timing	
reference	4-6
system	6-2
Title, menu	3-9
Tool, chip carrier extraction	5-3
Trans Rate Toggle Switch	3-6
Transition Mode Command	4-17
Transition Select Command	4-19
Transparency, menu item	3-12
Triggers, GPI	3-7
Triggers, tally	3-8
TX Output	2-16, 3-17

U

U10, boot flash chip	5-3
Unpacking	2-2
Unshaped key	3-12
Upgrading software	5-1, 5-2
User, CDK-111A-Lite	1-4

V

Value Column	3-9
Video	
fill option	3-12
format, menu item	3-14
input and output cable connections	2-6
input specifications	6-4
output specifications	6-4

system	1-4
--------------	-----

W

Write Command, Format of Second Byte	4-8
Write Commands	4-7

