

ADC-8032B(-S)

Analog Composite to SDI Video Decoder User Manual

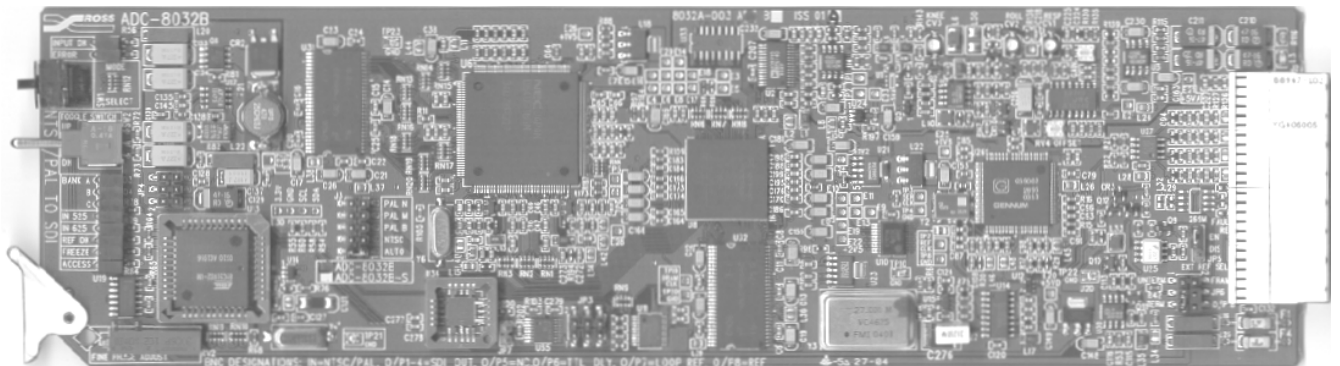

Ross Part Number: 8032BD-004
Issue: 02B

ADC-8032B • Analog Composite to SDI Video Decoder User Manual

- Ross Part Number: **8032BD-004**
- Document Issue: **02B**
- Printing Date: January 25, 2006. Printed in Canada.
- Software Issue: **1.00**

The information contained in this User Manual is subject to change without notice or obligation.

Copyright

© 2006 Ross Video Limited. All rights reserved.

Contents of this publication may not be reproduced in any form without the written permission of Ross Video Limited. Reproduction or reverse engineering of copyrighted software is prohibited.

Notice

The material in this manual is furnished for informational use only. It is subject to change without notice and should not be construed as a commitment by Ross Video Limited. Ross Video Limited assumes no responsibility or liability for errors or inaccuracies that may appear in this manual.

Trademarks

-  is a registered trademark of Ross Video Limited.
- Ross, ROSS, ROSS®, and MLE are registered trademarks of Ross Video Limited.
- All other product names and any registered and unregistered trademarks mentioned in this manual are used for identification purposes only and remain the exclusive property of their respective owners.

Important Regulatory and Safety Notices

Before using this product and any associated equipment, refer to the “Important Safety Instructions” listed below so as to avoid personnel injury and to prevent product damage.

Products may require specific equipment, and /or installation procedures be carried out to satisfy certain regulatory compliance requirements. Notices have been included in this publication to call attention to these Specific requirements.

Symbol Meanings



This symbol on the equipment refers you to important operating and maintenance (servicing) instructions within the Product Manual Documentation. Failure to heed this information may present a major risk of damage or injury to persons or equipment.



Warning

The symbol with the word “**Warning**” within the equipment manual indicates a potentially hazardous situation, which if not avoided, could result in death or serious injury.



Caution

The symbol with the word “**Caution**” within the equipment manual indicates a potentially hazardous situation, which if not avoided, may result in minor or moderate injury. It may also be used to alert against unsafe practices.



Notice

The symbol with the word “**Notice**” within the equipment manual indicates a situation, which if not avoided, may result in major or minor equipment damage or a situation which could place the equipment in a non-compliant operating state.



ESD

Susceptibility

This symbol is used to alert the user that an electrical or electronic device or assembly is susceptible to damage from an ESD event.

Important Safety Instructions



Caution

This product is intended to be a component product of the RossGear 8000 series frame. Refer to the RossGear 8000 series frame User Manual for important safety instructions regarding the proper installation and safe operation of the frame as well as it's component products.



Warning

Certain parts of this equipment namely the power supply area still present a safety hazard, with the power switch in the OFF position. To avoid electrical shock, disconnect all A/C power cords from the chassis' rear appliance connectors before servicing this area.



Warning

Service barriers within this product are intended to protect the operator and service personnel from hazardous voltages. For continued safety, replace all barriers after any servicing.

This product contains safety critical parts, which if incorrectly replaced may present a risk of fire or electrical shock. Components contained within the product's power supplies and power supply area, are not intended to be customer serviced and should be returned to the factory for repair.

To reduce the risk of fire, replacement fuses must be the same type and rating.

Only use attachments/accessories specified by the manufacturer.

EMC Notices

US FCC Part 15

This equipment has been tested and found to comply with the limits for a class A Digital device, pursuant to part 15 of the FCC Rules. These limits are designed to provide reasonable protection against harmful interference when the equipment is operated in a commercial environment. This equipment generates, uses, and can radiate radio frequency energy and, if not installed and used in accordance with the instruction manual, may cause harmful interference to radio communications. Operation of this equipment in a residential area is likely to cause harmful interference in which case users will be required to correct the interference at their own expense.



Notice

Changes or modifications to this equipment not expressly approved by Ross Video Ltd. could void the user's authority to operate this equipment.

CANADA

This Class "A" digital apparatus complies with Canadian ICES-003.

Cet appareil numérique de classe "A" est conforme à la norme NMB-003 du Canada.

EUROPE

This equipment is in compliance with the essential requirements and other relevant provisions of **CE Directive 93/68/EEC**.

INTERNATIONAL

This equipment has been tested to **CISPR 22:1997** along with amendments **A1:2000** and **A2:2002** and found to comply with the limits for a Class A Digital device.



Notice

This is a Class A product. In domestic environments this product may cause radio interference in which case the user may have to take adequate measures.

Maintenance/User Serviceable Parts

Routine maintenance to this RossGear product is not required. This product contains no user serviceable parts. If the module does not appear to be working properly, please contact Technical Support using the numbers listed under the "Contact Us" section on the last page of this manual. All RossGear products are covered by a generous 5-year warranty and will be repaired without charge for materials or labor within this period. See the "Warranty and Repair Policy" section in this manual for details.

Environmental Information

The equipment that you purchased required the extraction and use of natural resources for its production. It may contain hazardous substances that could impact health and the environment.

To avoid the potential release of those substances into the environment and to diminish the need for the extraction of natural resources, Ross Video encourages you to use the appropriate take-back systems. These systems will reuse or recycle most of the materials from your end-of-life equipment in an environmentally friendly and health conscious manner.

The crossed-out wheeled bin symbol invites you to use these systems.

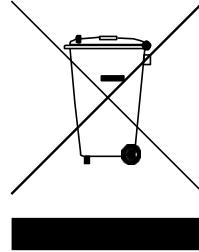

If you need more information on the collection, reuse, and recycling systems, please contact your local or regional waste administration.

You can also contact Ross Video for more information on the environmental performances of our products.



Contents

Introduction	1-1
In This Chapter	1-1
A Word of Thanks	1-1
Overview	1-2
Functional Block Diagram.....	1-2
Features.....	1-3
Documentation Terms	1-4
Abbreviations.....	1-4
Installation and Setup	2-1
In This Chapter	2-1
Static Discharge	2-1
Unpacking.....	2-1
Jumper Locations.....	2-2
Video Input.....	2-2
Reference Selection	2-2
Reference Termination.....	2-3
SMPTE Fault Reporting.....	2-3
Board Installation.....	2-3
BNC Labels	2-3
Cable Connections	2-4
User Controls	3-1
In This Chapter	3-1
User Controls	3-1
Using Banks	4-1
In This Chapter	4-1
General Operating Rules.....	4-1
Selecting Banks	4-2
Function Tables	4-2
Using Bank A Functions.....	4-6
Using Bank B Functions.....	4-12
Using Bank C Functions.....	4-14
Timing Modes.....	4-17
SMPTE 269M Fault Reporting	5-1
In This Chapter	5-1
Overview	5-1
Jumper Setup	5-2
Frame Connections	5-2
Details.....	5-2

Frame Synchronizer Upgrade	6-1
In This Chapter.....	6-1
Equipment Supplied.....	6-1
Record Settings.....	6-2
Software Upgrade Procedure.....	6-4
Firmware Upgrade Procedure.....	6-5
Confirm Upgrade.....	6-6
Specifications	7-1
In This Chapter.....	7-1
Technical Specifications.....	7-2
Service Information	8-1
In This Chapter.....	8-1
Troubleshooting Checklist.....	8-1
Warranty and Repair Policy.....	8-2
Ordering Information	9-1
In This Chapter.....	9-1
ADC-8032B and Related Products.....	9-1

Introduction

In This Chapter

This chapter contains the following information sections:

- A Word of Thanks
- Overview
- Functional Block Diagram
- Features
- Documentation Terms

A Word of Thanks

Congratulations on choosing the Ross Video **ADC-8032B Analog Composite to SDI Video Decoder**. You have purchased a powerful, versatile, and advanced decoder. The ADC-8032B is part of a full line of Digital Conversion Products within the RossGear Terminal Equipment family of products, backed by Ross Video's experience in engineering and design expertise since 1974.

You will be pleased at how easily your new ADC-8032B fits into your overall working environment. Equally pleasing is the product quality, reliability and functionality. Thank-you for joining the group of worldwide satisfied Ross Video customers!

Should you have a question pertaining to the installation and operation of your ADC-8032B, please contact us at the numbers listed in this publication. Our technical support staff is always available for consultation, training, or service.

Overview

The ADC-8032B is a 10-bit broadcast quality decoder with a 12-bit analog to digital converter. It is specifically designed for broadcast or production situations in which an analog PAL-B, PAL-M, PAL-N, or NTSC composite signal must be converted to a component SDI signal. Four SDI outputs are provided.

The ADC-8032B fits into the Ross 8000 series digital frames, with four cards in the DFR-8104A (1RU), and up to ten cards in the DFR-8110A (2RU). Please refer to the frame User Manual for specific ventilation and cooling instructions to maintain optimum operating conditions. This card also fits into Leitch* FR-6800 series frames to provide you with greater installation versatility.

The ADC-8032B is available in two different models:

- **ADC-8032B** - The base model decoder includes **Proc Amp**, **Line Delay**, and **Line Synchronizer** modes.
- **ADC-8032B-S** - The “S” model includes a **Frame Synchronizer**, along with all the features available on the ADC-8032B

The ADC-8032B-S version comes with a full featured frame synchronizer, capable of synchronizing incoming video to house reference. Various timing modes are available to accommodate most situations. New techniques in frame synchronization contribute to the board’s low power requirements and compact design. The complete circuit for the ADC-8032B, including a 12-bit A-D converter, decoder, frame (or line) synchronizer, serializer, tracking delay pulse, and microprocessor is contained on a single DA-sized card. Additional daughter cards are not required.

A rich set of features is instantly accessible using simple card-edge switches and controls in conjunction with a concise Heads-Up Display. The ADC-8032B’s 10-bit decoding process provides excellent performance with all types of picture sources. In order to achieve the highest level of precision, all signal processing and decoding is performed entirely in the digital domain. The decoder uses adaptive 3D, 3-line, and 5-line filters with advanced control algorithms.

To simplify configuration, the ADC-8032B offers a Heads-Up Display for most board-level adjustments. This display is especially convenient during setup, and for programming several ADC-8032B cards with identical configurations. With the display enabled, the parameter currently being adjusted has its value super-imposed over *all* board outputs.

Functional Block Diagram

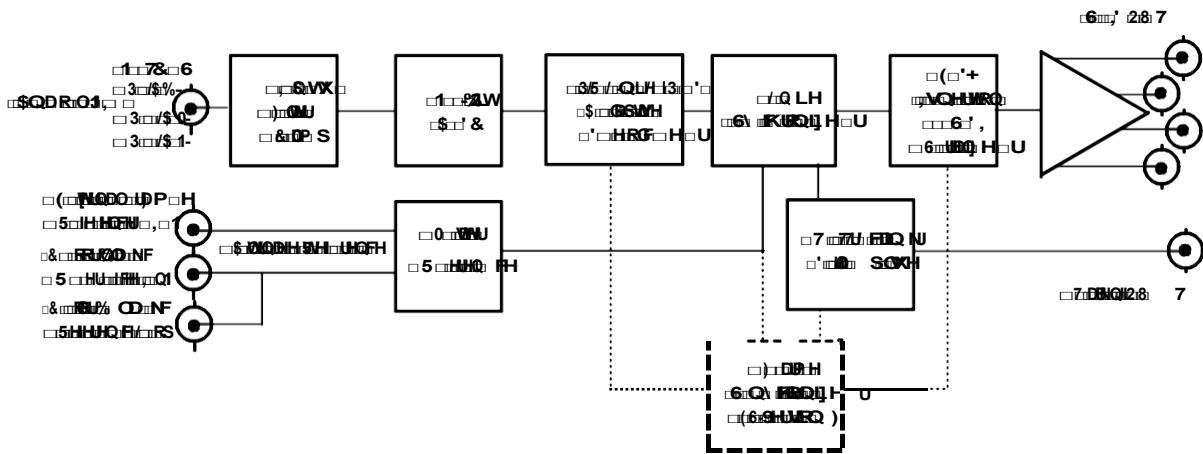

Figure 1. Simplified Block Diagram of ADC-8032B Functions

* Leitch is a trademark of Leitch Technology Corporation

Features

The following features make the ADC-8032B the most flexible, high-quality decoding card for your analog to digital conversion requirements:

- 10-bit decoding with 3D/3-line/5-line adaptive comb filters
- 12-bit analog to digital conversion
- Handles difficult signals such as satellite or microwave feeds
- Compact design on a single DA-sized card
- Heads-Up display
- Optional Frame Synchronization (no daughter card required)
- Field-upgradeable Frame Synchronization option available
- Extensive Proc Amp controls
- Freeze modes
- Hot-switches
- Horizontal and vertical timing adjustments
- Programmable vertical interval blanking
- Setup adjustment
- Black level offset
- Passes Super Black
- Status indicator LEDs on card edge
- Jumper-selectable NTSC / PAL-B / PAL-M / PAL-N or Auto-Detect
- Choice of reference inputs
- Four serial digital outputs
- Tracking Delay Output for companion audio synchronizer
- Built-in test signals
- SMPTE 269M Fault Reporting
- Fits Ross Video 8000 series digital products frames and Leitch FR-6800 series frames
- 5-year transferable warranty

Documentation Terms

The following terms are used throughout this guide:

- “**Frame**” refers to the **DFR-8104A** and **DFR-8110A** frames that house the **ADC-8032B** card.
- All references to the **DFR-8104A** and **DFR-8110A** also include the **DFR-8104A-C** and **DFR-8110A-C** versions with the cooling fan option. See the respective User Manuals for details.
- “**Operator**” and “**User**” both refer to the person who uses the **ADC-8032B**.
- “**Board**”, “**Card**”, and “**Module**” all refer to the **ADC-8032B** module board itself, including all components and switches.
- “**System**” and “**Video system**” refers to the mix of interconnected production and terminal equipment in which the **ADC-8032B** operates.
- “**525-line mode**” refers to broadcast situations using **NTSC** or **PAL-M** composite (analog) signal reference inputs.
- “**625-line mode**” refers to broadcast situations using **PAL-B** or **PAL-N** composite (analog) signal reference inputs. All references to **PAL** in this manual implies **PAL-B / PAL-M / PAL-N**.
- All references to **PAL-N** are “combination N” (ITU-R BT. 470-6)

Abbreviations

The following abbreviations may be used throughout the text:

Abbreviation	Definition
ADC	Analog to Digital Converter
A-D	Analog-to-Digital
D-A	Digital-to-Analog
DA	Distribution Amplifier
DAC	Digital to Analog Converter
DDR	Digital Disk Recorder
DIS	Disable
DVR	Digital Video Recorder
EN	Enable
LOW SIG	Low Signal
RU	Rack Unit
SDI	Serial Digital Interface
VCR	Video Cassette Recorder
VTR	Video Tape Recorder

Installation and Setup

In This Chapter

This chapter contains the following information sections:

- Static Discharge
- Unpacking
- Jumper Locations
- Video Input
- Reference Selection
- Reference Termination
- SMPTE Fault Reporting
- Board Installation
- BNC Labels
- Cable Connections

Static Discharge

Whenever handling the ADC-8032B and other related equipment, please observe all static discharge precautions as described in the following note:



Static discharge can cause serious damage to sensitive semiconductor devices. Avoid handling circuit boards in high static environments such as carpeted areas, and when wearing synthetic fiber clothing. Always exercise proper grounding precautions when working on circuit boards and related equipment.

Unpacking

Unpack each ADC-8032B you received from the shipping container, and check the contents against the packing list to ensure that all items are included. If any items are missing or damaged, contact your sales representative or Ross Video directly.

Jumper Locations

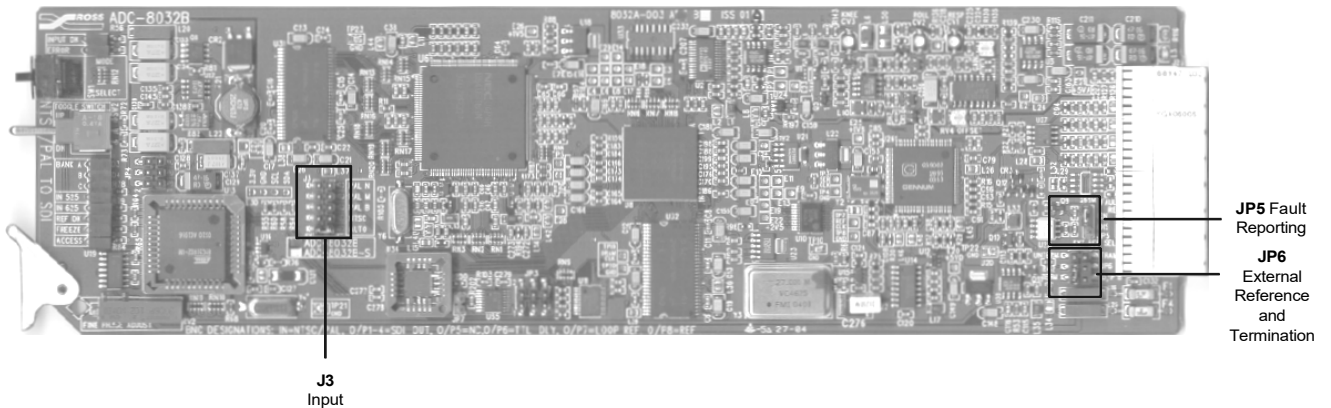

Figure 2. Jumper Locations

Use the following sections to set up ADC-8032B jumpers. These setups are performed *before* installing the unit in the frame, but may be repeated as required. Refer to Figure 2 for card jumper locations.

Video Input

Using the figure above and the card silk-screening, set **J3 (Input Select)** to select the input video standard:

- **Auto** — automatically select between NTSC / PAL-B / PAL-M / PAL-N (default setting)
- **NTSC** — forces NTSC decoding
- **PAL-B** — forces PAL-B decoding
- **PAL-M** — forces PAL-M decoding
- **PAL-N** — forces PAL-N decoding

Reference Selection

An analog composite reference is required for Line Sync and Frame Sync modes. The reference can come from BNC 7 or 8 (BNC 7 and 8 are passively connected on the card) or from the Frame. See Figure 3. Use **JP6** to set reference options:

- To select the frame as the reference source, install the jumper in the **FRAME** position (the upper two pins)

Note

When the frame is the reference source, the termination jumper must be set to **UNTERM** position.

- To select BNC 7 or 8 as the reference source, install the jumper in the **O/P8** position (the lower two pins)

Reference Termination

The reference signal can be terminated on the card. See Figure 3. Use **JP6** to set reference termination options:

- To terminate the reference on this card install the jumper in the **TERM** position (the lower two pins).
- To leave the reference un-terminated install the jumper in the **UNTERM** position (the upper two pins).

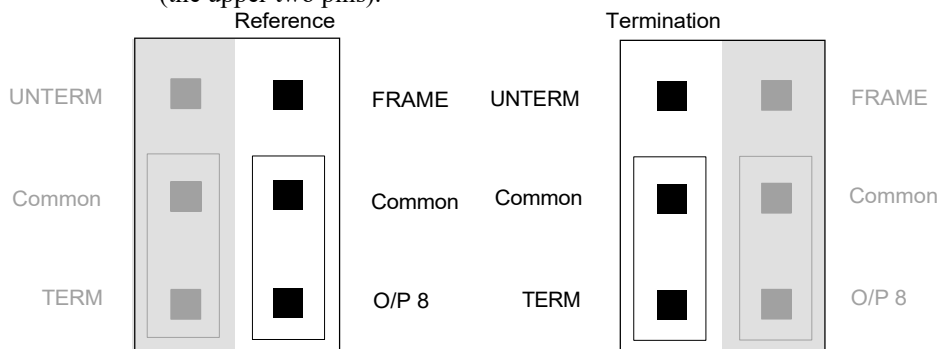

Figure 3. Jumper 6 Reference and Termination Option Pin Locations

SMPTE Fault Reporting

(Optional) Using Figure 2 and the card silk-screening, set Jumper **JP5 (269M Fault Reporting)** to enable or disable the card's SMPTE alarm:

- Set jumper to **EN** to enable SMPTE fault reporting (default setting)
- Set jumper to **DIS** to disable SMPTE fault reporting

(See Chapter 5, "SMPTE 269M Fault Reporting" for details on fault reporting.)

Board Installation

Use the following steps to install the ADC-8032B in a RossGear 8000 series digital distribution frame:

1. Refer to the User Manual of the RossGear 8000 series frame, to ensure that the frame is properly installed according to instructions. If this module is to be installed in any compatible frame other than a Ross Video product, refer to the frame manufacturer's manual for specific instructions.
2. Please note that heat and power distribution requirements within a frame may dictate specific slot placement of cards. Cards with many heat-producing components should be arranged to avoid areas of excess heat build-up, particularly in frames using convectional cooling.
3. After selecting the desired frame installation slot, hold the ADC-8032B card by the edges and carefully align the card edges with the slots in the frame. Then fully insert the card into the frame until the rear connection plug is properly seated.

BNC Labels

Affix the supplied BNC label, as per the included instructions, to the BNC area on the rear of the rack frame.

Cable Connections

This section provides instructions for connecting cables to the ADC-8032B when mounted in RossGear 8000 series Digital Products Frames. See the following frame rear panel diagram for BNC input and output designations:

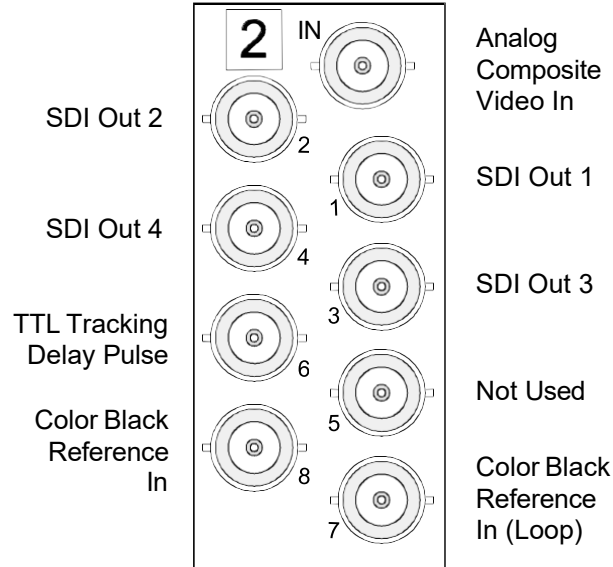

Figure 4. BNC Designations for RossGear Frames

Connect the BNC cables as follows:

1. Connect the composite signal to be converted to the IN BNC.
2. Connect BNCs 1 through 4 to the inputs of four component SDI devices.
3. Connect BNC 6 to any device that needs to track the video delay through the 8032B or 8032B-S. (RossGear ADL-8520 AES/EBU Auto Tracking Audio Delay)

The Tracking Delay Pulse is a positive 5V pulse. Its width tracks the video delay as it passes through the card. The ADC-8032B tracking delay pulse tracks up to 2 video lines, the ADC-8032B-S up to 2 fields.
4. Connect a video reference one of two ways (please refer to the “**Jumper Setup**” section)
 - If you wish to reference the card from the frame’s Master Reference connector, ensure that a composite analog color black reference signal is connected to the REF BNC on the frame (see Figure 7 in Chapter 5). Be sure that **JP6** is set to **FRAME** and **UNTERM**.
 - If you wish to obtain the reference directly from the card’s back plane, connect a composite analog color black reference to BNC 7 or 8. Be sure that **JP6** is set to **O/P 8**. BNC 7 and 8 are passively connected.

To terminate the reference on the card, install the jumper on **JP6** in the **TERM** position. See Figure 3. If un-terminated (**JP6** in the **UNTERM** position) the reference can be looped to another source.

User Controls

In This Chapter

This section contains a description of the ADC-8032B user controls.

Note

The ADC-8032B uses card edge controls for changing operational parameters. The card defaults with switch access set to the locked position. Refer to the “**Bank A - F: Lock/Unlock Switch Access**” section in Chapter 4, “**Using Banks**”, before attempting to make any adjustments.

User Controls

The following are general descriptions of the user controls identified in the figure below.

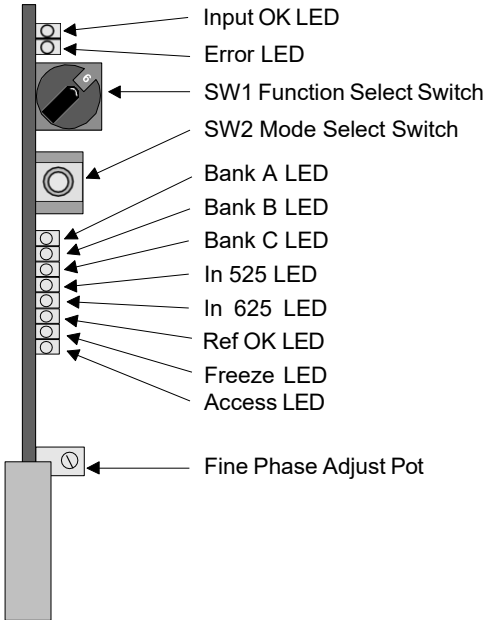

Figure 5. Card-edge User Controls

Function Select Switch – SW1

The (**SW1**) **Function Select** switch is a 16-position rotary switch used to select functions such as proc amp controls and timing adjustment menu items. The SW1 switch works in conjunction with the SW2 toggle switch; first, the function category is selected with SW1, and then the SW2 toggle switch is used to select modes or configuration settings within that function selection. See Chapter 4, “**Using Banks**” for complete details.

Mode Select Switch – SW2

The (**SW2**) **Mode Select** switch is used to enable, disable, and select specific ADC-8032B *functional modes*, or *configurations*, within the operational function menu (selected first with the SW1 Function Select switch). The **Mode Select** switch is a 3-position momentary toggle switch with an automatic spring-return to the center position.

There are two methods of toggling SW2 to select basic and advanced level menu items:

- Single toggle to select single options
- Hold toggle to scroll through multiple values or options

Toggling the switch for menu selection is made according to two basic menu design categories:

- menu selections utilizing a scrolling *wrap-around* style of selection (from last menu item directly back to first menu item)
- menu selections utilizing a *bi-directional* style of selection (with upper and lower range limits)

Fine Phase Adjust Potentiometer

The **RV2** Fine Phase Adjust potentiometer adjusts the board’s output delay in sub-pixel increments, with a range of 0 (zero) to approximately 40ns.

Status and Selection LEDs

The front edge of the card features ten LEDs that display the status of the input signals, and indicate menu function and configuration selections.

As selections are made from the menu tables, (see Chapter 4, “Using Banks” for complete bank menu table descriptions), the LEDs display the status of the input signals for each bank, as well as menu function and configuration selections. Basic LED displays and descriptions are provided in the following table:

Table 1. Selection and Status LED Descriptions

LED	Color	Display and Description
INPUT OK	Green	When lit, this LED indicates that the card is functioning normally and that no anomalies have been detected. Both of the following conditions must be satisfied: <ul style="list-style-type: none"> • A valid input signal is present • A valid reference signal is present when a reference is required, and that the reference standard matches the input standard. Selecting Line Sync or Frame Sync modes require that a reference signal is present
ERROR	Red	When lit, this LED indicates that conditions for INPUT OK are not met. Mutually exclusive with INPUT OK LED.
BANK A	Green	When lit, this LED confirms that Bank A is selected.
BANK B	Green	When lit, this LED confirms that Bank B is selected.
BANK C	Green	When lit, this LED confirms that Bank C is selected.
IN 525	Green	Lights when the input signal is 525-lines (NTSC or PAL-M).
IN 625	Green	Lights when the input signal is 625-lines (PAL or PAL-N).
REF OK	Green	When lit, this LED indicates a reference signal is present at the Master REF or BNC input, and that the reference signal is locked. <ul style="list-style-type: none"> • <i>On</i> = External reference standard matches the input standard • <i>Flashing</i> = External reference standard does not match the input standard • <i>Off</i> = No external reference is present
FREEZE	Yellow	When lit, this LED indicates that the output is frozen (ADC-8032B-S only).
ACCESS	Yellow	When lit, this LED indicates that Switch Access is unlocked. ADC-8032B controls (See Bank A, B, and C Functions) are accessible.

Using Banks

In This Chapter

This section provides a detailed explanation on using Bank functions. The following topics are discussed:

- General Operating Rules
- Selecting Banks
- Function Tables
- Using Bank A Functions
- Using Bank B Functions
- Using Bank C Functions
- Timing Modes

General Operating Rules

Please note the following important operating rules for the ADC-8032B:

- Whenever the card is powered up, it defaults to Bank A, and the Bank A LED is lit.

Note

The card defaults with switch access set to the locked position. To unlock the access refer to the “**Bank A-F: Lock/Unlock Switch Access**” section on page 4-11 in this chapter before attempting to make any adjustments.

- For each of the supported video formats (NTSC / PAL-B / PAL-M / PAL-N) the card stores the default or user-adjusted video settings independently in non-volatile memory. The selection of settings is determined by the setting of **J3 Input select**, the video standard jumper.
- Always check to see that the **Input OK** LED is lit. If not, check that the input is valid. If a reference is used, check that the reference is valid and that the reference standard matches the input standard.

- Before making adjustments, choose the method that you wish to use. Two methods are available:
 1. **No display** - Adjustments are made using the **Function Select** and **Mode Select** switches, without the assistance of the Heads-Up Display. Results should be confirmed with test equipment suitable for measuring the parameter being adjusted (such as a waveform monitor or vector scope).
 2. **Heads-Up Display** - Adjustments are made using **Function Select** and **Mode Select** switches in conjunction with the Heads-Up Display. Ensure that the Heads-Up Display is enabled (Bank A, position 1). Note that the display is superimposed over *all* ADC-8032B video outputs.

Operating Conventions For Function Tables

The following rules apply to the function tables that are used throughout this section:

- The label “ + ” instructs you to toggle the **Mode Select** switch (**SW2**) *up* momentarily.
- The label “ - ” instructs you to toggle the **Mode Select** switch (**SW2**) *down* momentarily.
- The label “ + (h) ” instructs you to *hold* the **Mode Select** switch (**SW2**) *up* for one second.
- The label “ - (h) ” instructs you to *hold* the **Mode Select** switch (**SW2**) *down* for one second.

Selecting Banks

Function Select switch functionality is divided into three banks of functions. Use the following steps to select Bank A, B or C as required.

1. Rotate **Function Select (SW2)** to position 0. Note that position 0 is always used to select the bank, regardless of the bank that you are currently using.
2. Toggle **Mode Select (SW2)** up or down to choose the desired bank. Three positions are available: Bank A, B or C.
3. The table below illustrates each switch function, along with the Heads-Up Display label, the Status LED indication, and the default value. If you are not using a display, be sure to verify your selection on the Status LEDs.

Table 2. Switch and Bank Selection

Mode Select	Heads-up Display Label	Status LED	Default Bank
+ A	BANK A	BANK A	A
B	BANK B	BANK B	
- C	BANK C	BANK C	

Function Tables

This section presents a detailed charting of all board-level ADC-8032B functions in the following three tables. The operational usage is explained in the next section.

Bank A Function Table

Table 3. Function Select: Bank A Function Table

Function Select	Function	Mode Select Options	Heads Up Display On-Screen Label and Value		Default Value
0	Bank Select	+ A - B - C	BANK	A B C	A
1	Heads-Up Display	+ (h) On - Off	HEADS UP	ON OFF	OFF
2	N/A				
3	N/A				
4	Decode Mode ^m (NTSC)	+ 3 Line - 3D Adaptive	DECODE	3 LINE 3D ADAPT	3D ADAPT
4	Decode Mode ^m (PAL)	5 Line	DECODE	5 LINE	5 LINE
5	Test Pattern	+ Full Field Color Bars SDI Check Field - Off	TEST PAT	FF BARS PATH OFF	OFF
6	N/A				
7	N/A				
8	Video Gain ^m	+ Increase - Decrease	VID GAIN	(###.#)%	100.0% *
9	Black Level Offset ^m	+ Increase - Decrease	BLK OFF	(##.#) IRE	0.0 IRE *
A	Chroma Gain ^m	+ Increase - Decrease	CHROMA	(###.#)%	100.0% *
B	Hue ^m	+ Increase - Decrease	HUE	(##.##) DEG.	0.00 DEG. *
C	C _B Gain ^m	+ Increase - Decrease	C _B GAIN	(###.#)%	100.0% *
D	AGC	+ Both Luma Chroma - Off	AGC	BOTH LUMA CHROMA OFF	OFF *
E	Factory Defaults	+ (h) Reset All - (h) Reset Proc Amp	DEFAULT	ALL RST PROC RST	N/A
F	Switch Access **	+ Locked - (h) Unlocked	ACCESS	LOCKED UNLOCKED	LOCKED

Note

Functions, as listed in the Function column as being stored in memory, always power up in the last known state. All other items, however, power up in the default state, regardless of their previous state.

* Indicates Proc Amp controls that are affected by position E, Factory Defaults function.

** Locking Switch Access shuts off the Heads-up Display. Unlocking will not restore the display if it was previously enabled. This must be performed manually.

^m Stored in non-volatile memory

Bank B Function Table

Table 4. Function Select: Bank B Function Table

Function Select	Function	Mode Select Options	Heads Up Display On-Screen Label and Value	Default Value
0	Bank Select	+ A B - C	BANK A B C	A
1	Setup ^m	+ On - Off	SETUP ON OFF	ON** OFF *
2	N/A			
3	VI Blanking ^m	+ Blank - Pass Through	VI BLANK BLANK PASS PASS	PASS
4	VI End ^m	+ Increase - Decrease	VI END (##)	20
5	SuperBlack ^m	+ Pass Through - Clip	SUPER BLK PASS CLIP CLIP	PASS
6	V Bit Lock ^m (NTSC only)	+ Line 20 - Line 10	V BIT LOC 20 10	20
7	N/A			
8	N/A			
9	N/A			
A	N/A			
B	N/A			
C	N/A			
D	N/A			
E	N/A			
F	N/A			

Note

Functions, as listed in the Function column as being stored in memory, always power up in the last known state. All other items, however, power up in the default state, regardless of their previous state.

- * Indicates default PAL-B/PAL-N setting.
- ** Indicates default NTSC/PAL-M setting.
- ^m Stored in non-volatile memory

Bank C Function Table

Table 5. Function Select: Bank C Function Table

Function Select	Function	Mode Select Options	Heads Up Display On-Screen Label and Value		Default Value
0	Bank Select	+ A - B - C	BANK	A B C	A
1	Timing Mode ^m	+ Frame Sync* Frame Delay* - Line Sync Line Delay	TIME MODE	FS FD LS LD	LS (FS on S model)
2	H Delay ^m	+ Increase - Decrease	H DELAY	(#####)	0
3	H Reset	+ Zero - No action	H RESET	ZERO	N/A
4	V Delay ^m	+ Increase - Decrease	V DELAY	(#)	0
5	V Reset	+ Zero - No action	V RESET	ZERO	N/A
6	Set Min. Delay	+ Zero - No action	MIN DEL	ZERO	N/A
7	Input Mode ^m	+ VTR input - Standard input	IN MODE	VTR STAND	STAND
8	Freeze Mode ^{m, **}	+ Frame Field 2 - Field 1	FRZ MODE	FRAME FLD 2 FLD 1	FLD 1
9	Forced Freeze	+ Freeze** - Pass Through	FREEZE	FORCE PASS	PASS
A	Input Loss Mode ^m	+ Freeze** - No Output Black	IN LOSS	FREEZE NO OUTPUT BLACK	BLACK
B	Hotswitch Mode ^m	+ Freeze** - Black Off	HOTSW MD	FREEZE BLACK OFF	OFF
C	Forced Black	+ (h) On - (h) Off	FRCD BLK	ON OFF	OFF
D	Forced Mono	+ (h) On - (h) Off	FRCD MONO	ON OFF	OFF
E	N/A				
F	N/A				

Note

Functions, as listed in the Function column as being stored in memory, always power up in the last known state. All other items, however, power up in the default state, regardless of their previous state.

* Only available on ADC-8032B-S.

** When Freeze mode is activated the freeze is determined by C-8 (Freeze Mode).

^m Stored in non-volatile memory

Using Bank A Functions

The following topics are discussed in this section:

- Heads-up Display
- Decode Mode
- Test Pattern
- Video Gain
- Black Level Offset
- Chroma Gain
- Hue
- C_B Gain
- AGC
- Factory Defaults
- Lock/Unlock Switch Access

Important

The card defaults with switch access set to the locked position. To unlock the access refer to the “**Bank A-F: Lock/Unlock Switch Access**” section in this chapter before attempting to make any adjustments.

Bank A-1: Heads-up Display

Use the following steps to enable or disable the Heads-up display:

1. Select Bank A, and rotate **Function Select** to position 1.
2. Choose the desired display mode:
 - Hold **Mode Select** *up* for one second to enable the display.
 - Hold **Mode Select** *down* to disable the display.

Bank	Function Select	Mode Select	Heads-Up Display Label	Default
A	1	+ (h) On - Off	HEADS UP ON OFF	OFF

Note

The display is superimposed over all ADC-8032B video outputs. Do not use this feature with “on-air” signals.

Bank A-4: Decode Mode

The **Decode Mode** function allows you to select 3 Line or 3D Adaptive decode modes in NTSC. In PAL-B, PAL-M, and PAL-N the decoder uses a 5 line aperture.

Note

Bank A Menu 4 information will differ depending on the input signal format.

Use the following steps to enable the Decode Mode options:

NTSC

1. Select Bank A, and rotate **Function Select** to position 4.
2. Choose the desired display mode:
 - Toggle **Mode Select** *up* for one second to enable the 3 Line decode function.
 - Toggle **Mode Select** *down* to enable the 3D Adaptive decode function.

PAL

1. Select Bank A, and rotate **Function Select** to position 4.

The card defaults to 5 line decode mode.

Bank	Function Select	Mode Select	Heads-Up Display Label	Default	
A	4 (NTSC)	+	3 Line	DECODE 3 LINE	3D ADAPT
		-	3D Adaptive	3D ADAPT	
A	4 (PAL)		5 Line	DECODE 5 LINE	5 LINE

Bank A-5: Test Pattern

The **Test Pattern** function allows you to select from two test pattern types or disable the test pattern option.

Use the following steps to select or disable the test pattern function:

1. Select Bank A, and rotate **Function Select** to position 5.
2. Select the desired pattern according to the table below:
 - Toggle **Mode Select** *up* to advance up the list.
 - Toggle **Mode Select** *down* to descend down the list.

Bank	Function Select	Mode Select	Heads-Up Display Label	Default	
A	F	+	Full Field Color Bars	TEST PAT FF BARS	OFF
			SDI Check Field	PATH	
		-	Off	OFF	

Note

When using the SDI Check Field test pattern, the Heads Up display must be Off for the test pattern to provide accurate results.

Bank A-8: Video Gain

Use the following steps to adjust the ADC-8032B's output video gain:

1. Select Bank A, and rotate **Function Select** to position 8.
2. Adjust video gain up or down as required:
 - Toggle **Mode Select** *up* to increase video gain.
 - Hold **Mode Select** *up* to increase video gain continuously.
 - Toggle **Mode Select** *down* to decrease video gain.
 - Hold **Mode Select** *down* to decrease video gain continuously.

Bank	Function Select	Mode Select	Heads-Up Display Label	Default
A	8	+ Increase - Decrease	VID GAIN (###.#)%	100%

Note

Video Gain is one of the six “Proc Amp” controls that can be reset using **Factory Defaults** (Bank A, position E).

Bank A-9: Black Level Offset

This setting is a black level offset that is *not* affected by the **NTSC Setup** function (Bank B, position 1). For example, with **Black Level Offset** at 1 IRE, a setup level of 7.5 IRE, and **NTSC Setup** off, the black level will be 8.5 IRE. With **NTSC Setup** on and a setup level of 7.5 IRE, the black level will be 1.0 IRE. Use the following steps to change the card's output black level.

1. Select Bank A, and rotate **Function Select** to position 9.
2. Choose the desired Black Level Offset setting:
 - Toggle **Mode Select** *up* to increase the black level offset.
 - Hold **Mode Select** *up* to increase the black level offset continuously.
 - Toggle **Mode Select** *down* to decrease the black level offset.
 - Hold **Mode Select** *down* to decrease the black level offset continuously.

Bank	Function Select	Mode Select	Heads-Up Display Label	Default
A	9	+ Increase - Decrease	BLK OFF (##.#) IRE	0 IRE

Note

Black Level Offset is one of the six “Proc Amp” controls that can be reset using **Factory Defaults** (Bank A, position E).

Bank A-A: Chroma Gain

Use the following steps to adjust the ADC-8032B's output chroma gain:

1. Select Bank A, and rotate **Function Select** to position A.
2. Adjust chroma gain up or down as required:
 - Toggle **Mode Select** *up* to increase chroma gain.
 - Hold **Mode Select** *up* to increase chroma gain continuously.
 - Toggle **Mode Select** *down* to decrease chroma gain.
 - Hold **Mode Select** *down* to decrease chroma gain continuously.

Bank	Function Select	Mode Select	Heads-Up Display Label	Default
A	A	+ Increase - Decrease	CHROMA (###.#)%	100%

Note

Chroma Gain is one of the six “Proc Amp” controls that can be reset using **Factory Defaults** (Bank A, position E).

Bank A-B: Hue

Use the following steps to adjust the ADC-8032B's output hue:

1. Select Bank A, and rotate **Function Select** to position B.
2. Adjust hue (in degrees) as required:
 - Toggle **Mode Select** *up* to change the hue in a clockwise direction.
 - Hold **Mode Select** *up* to change the hue clockwise, continuously.
 - Toggle **Mode Select** *down* to change the hue in a counter-clockwise direction.
 - Hold **Mode Select** *down* to change the hue counter-clockwise, continuously.

Bank	Function Select	Mode Select	Heads-Up Display Label	Default
A	B	+ Increase - Decrease	HUE (##.##) DEG.	0 DEG.

Note

Hue is one of the six “Proc Amp” controls that can be reset using **Factory Defaults** (Bank A, position E).

Bank A-C: C_B Gain

Use the following steps to adjust the ADC-8032B's output C_B gain:

1. Select Bank A, and rotate **Function Select** to position C.
2. Adjust C_B Gain up or down as required:
 - Toggle **Mode Select** *up* to increase C_B gain.
 - Hold **Mode Select** *up* to increase C_B gain continuously.
 - Toggle **Mode Select** *down* to decrease C_B gain.
 - Hold **Mode Select** *down* to decrease C_B gain continuously.

Bank	Function Select	Mode Select	Heads-Up Display Label	Default
A	C	+ Increase - Decrease	C _B GAIN (###.#)%	100%

Note

C_B Gain is one of the six “Proc Amp” controls that can be reset using **Factory Defaults** (Bank A, position E).

Bank A-D: AGC

Use the following steps to enable or disable the Automatic Gain Control (AGC):

1. Select Bank A, and rotate **Function Select** to position D.
2. Choose the desired AGC state:
 - Toggle **Mode Select** *up* to advance up the list.
 - Toggle **Mode Select** *down* to descend down the list.

Bank	Function Select	Mode Select	Heads-Up Display Label	Default
A	D	+ Both Luma Chroma - Off	AGC BOTH LUMA CHROMA OFF	OFF

Note

AGC is one of the six “Proc Amp” controls that can be reset using **Factory Defaults** (Bank A, position E). Proc amp controls will still affect the video output even if the **AGC** is on.

Bank A-E: Factory Defaults

This function allows you to return all controls to their default values, or simply the six “Proc Amp” controls by themselves. Use the following steps to select factory default values:

1. Select Bank A, and rotate **Function Select** to position E.
2. Select the desired default settings:
 - Hold **Mode Select** up to reset all adjustments to their default values.
 - Hold **Mode Select** down to reset the six “Proc Amp” adjustments to their default values (**Video Gain, Black Level Offset, Chroma Gain, Hue, Cb Gain, and AGC**).

Bank	Function Select	Mode Select	Heads-Up Display Label	Default
A	E	+ (h) Reset All - (h) Reset Proc Amp	DEFAULT ALL RST PROC RST	N/A

Bank A-F: Lock/Unlock Switch Access

The **Switch Access** function allows you to lock or unlock user access to all adjustment parameters. The “lock” function should be performed after installation to secure all settings, and to prevent anyone from accidentally changing the settings. Note the following rules:

- When access is locked, no adjustments can be made and the Heads-Up Display is automatically turned off.
- When you unlock switch access and you wish to use the Heads-Up display again, you must manually enable it (Bank A, position 1).

Use the following steps to lock or unlock switch access:

1. Select Bank A, and rotate **Function Select** to position F.
2. Choose the desired access mode:
 - Toggle **Mode Select** *up* to lock switch access. Adjustments cannot be made, and the display is disabled. The **ACCESS LED** is off.
 - Hold **Mode Select** *down* for one second to unlock switch access. Adjustments can now be made. The **ACCESS LED** is on.

Bank	Function Select	Mode Select	Heads-Up Display Label	Default
A	F	+ Locked - (h) Unlocked	ACCESS LOCKED UNLOCKED	LOCKED

Using Bank B Functions

The following topics are discussed in this section:

- Setup
- VI Blanking
- VI End
- SuperBlack
- V Bit Lock

Bank B-1: Setup

Use the following steps to enable or disable setup:

1. Select Bank B, and rotate **Function Select** to position 1.
2. Choose the desired setup value:
 - Toggle **Mode Select** *up* to enable NTSC / PAL-M setup.
 - Toggle **Mode Select** *down* to disable NTSC / PAL-M setup.

Bank	Function Select	Mode Select	Heads-Up Display Label	Default
B	1	+ On - Off	SETUP ON OFF	ON* OFF**

* Indicates default NTSC / PAL-M setting

** Indicates default PAL-B / PAL-N setting

Bank B-3: VI Blanking

Use the following steps to blank the vertical interval, or allow the signals in the vertical interval to pass through the **ADC-8032B**:

1. Select Bank B, and rotate **Function Select** to position 3.
2. Choose the desired blanking mode:
 - Toggle **Mode Select** *up* to blank the vertical interval.
 - Toggle **Mode Select** *down* to pass the vertical interval.

Bank	Function Select	Mode Select	Heads-Up Display Label	Default
B	3	+ Blank - Pass Through	VI BLANK BLANK PASS	PASS

Bank B-4: VI End

The ADC-8032B has a programmable Vertical Interval that allows you to set where the VI ends and the first line of active video begins. Everything up to (but not including) the first line of active video is considered part of the Vertical Interval and will be affected by this function. In 525-line mode, signals in the vertical interval are passed without setup even if setup is enabled. The range in 525-line mode is line 20 to 22.

Note

VI End is only available in NTSC. In PAL-B, PAL-M, and PAL-N, **VI End** cannot be changed.

Use the following steps to select the end point for vertical blanking:

1. Select Bank B, and rotate Function Select to position 4.
2. Choose field 1 and field 2 settings, according to the table below:
 - Toggle Mode Select up to increase the line at which the VI ends.
 - Toggle Mode Select down to decrease the line at which the VI ends.

Bank	Function Select	Mode Select	Heads-Up Display Label	Default
B	4	+ Increase - Decrease	VI END (##)	20* or 23**

* 525-line mode (NTSC / PAL-M) value is selectable from 20-22

** 625-line mode (PAL-B / PAL-N) value is fixed at 23

Bank B-5: SuperBlack

Use the following steps to enable or disable the SuperBlack clipping function:

1. Select Bank B, and rotate **Function Select** to position 5.
2. Choose the desired SuperBlack setting:
 - Toggle **Mode Select** *up* to allow the input's active video signal to pass through unaltered.
 - Toggle **Mode Select** *down* to clip any value below black.

Bank	Function Select	Mode Select	Heads-Up Display Label	Default
B	5	+ Pass Through - Clip	SUPER BLK PASS CLIP	PASS

Bank B-6: V Bit Lock

Use the following steps to force the V bit for 10 or 20 lines.

Note

V Bit Lock is only available in NTSC. In PAL-B, PAL-M, and PAL-N, **V Bit Lock** cannot be changed.

V-BIT LOCK cannot be changed in 625

1. Select Bank B, and rotate **Function Select** to position 6.
2. Choose the desired line:
 - Toggle **Mode Select** *up* to have the V bit set to line 20.
 - Toggle **Mode Select** *down* to have the V bit set to line 10.

Bank	Function Select	Mode Select	Heads-Up Display Label	Default
B	6	+ Line 20 - Line 10	V BIT LOCK 20 10	20

Using Bank C Functions

The following topics are discussed in this section:

- Timing Mode
- H Delay
- H Reset
- V Delay
- V Reset
- Set Minimum Delay
- Freeze Mode
- Forced Freeze
- Input Loss Mode
- Hotswitch Mode
- Forced Black
- Forced Monochrome

Bank C-1: Timing Mode

The following topics are discussed in this section:

- About the Timing Mode
- Timing Mode Summary
- Bank C-1: Timing Mode Procedure

About the Timing Modes

The ADC-8032B and ADC-8032B-S offer two sets of timing modes; Line Delay/Sync and Frame Delay/Sync.

ADC-8032B Timing Mode Features

- Line Delay and Line Sync timing modes
- Two lines of memory
- Can be timed within one line in 37ns increments
- Can be field-upgraded to the Frame Sync version

ADC-8032B-S Timing Mode Features

- Frame Delay and Frame Sync as well as Line Delay and Line Sync timing modes
- One frame of memory
- Can be timed within one frame in 37ns increments

Both versions of the ADC-8032B offer a tracking delay output that pulses high at frame rate on BNC 6. The pulse width is a measurement of the video delay through the card. This is useful when connecting with devices which accept this type of measurement signal (such as the RossGear ADL-8520 AES Audio Delay Unit). On both versions, the fine phase potentiometer (**RV2**) is provided for sub-pixel adjustment.

Line Delay (ADC-8032B & ADC-8032B-S)

Line Delay mode uses the input signal to generate the output timing. There is a constant delay between the input and the output. The external reference is not used in any way. This is useful in applications where a constant delay through the card is required.

The delay through the card has a minimum value, as described in Chapter 7, “**Specifications**”. Output timing can be adjusted from this minimum delay up to an additional two lines in sub-pixel increments.

Line Sync (ADC-8032B & ADC-8032B-S)

Line Sync mode uses the external reference to generate the output timing on a line-by-line basis, but uses the input signal timing to decide when a frame begins.

Whenever a signal is received, the output-timing generator waits for the next falling edge of H Sync on the external reference before displaying the incoming line. The advantage of this mode is that as long as all input sources are timed to be on the same line, the output timing stays constant, regardless of which input is selected. This is very useful in that all sources to the **ADC-8032B** (for example, from a routing switcher) only need to be lined up to the same line.

The **Line Sync** mode has internal latency, so that using minimum delay still means that the output video will not be lined up with the external reference. To do so would have added even more latency, which would not be desirable. However, output timing can be delayed by up to two lines from the minimum delay point on, in sub-pixel increments, so that the output video can be lined up as required.

Note

If two input sources are not on the same line, then switching from one source to the other causes a jump in the output timing by an exact number of lines. For example, if the two sources are 2.5 lines apart, the output will jump by either 2 or 3 lines depending on the position of the sources with respect to the external reference.

Threshold Point

As the input signal is delayed in time, there comes a point where the output timing will have to jump by exactly one line (the output must always come after the input). This point is called the **threshold point**. When comparing the input signal with the external reference, the threshold point is 26 microseconds before the falling edge of the external reference. In other words, if the input signal's falling H sync edge is 26 microseconds before the external reference's falling H sync edge, the input signal is said to be on the threshold point.

In addition, there is built in hysteresis so that if an input source is on the threshold point, the output timing will be constant and will not jump back and forth by a line if the input signal varies slightly. However, if the input signal is exactly on the threshold point, the output timing may vary from one power up sequence to the other. In other words, the card may power up with *different timing* than the previous time it was powered-up. To avoid this condition, it is recommended to keep the input signal away from the threshold point. Two microseconds can be considered a safe distance.

Note

In Line Sync mode, you should keep the falling edge of the incoming video away from the threshold point.

Frame Delay (ADC-8032B-S)

The **Frame Delay** mode is identical to the **Line Delay** mode, except that the output timing can be delayed by up to a full frame of video. By using almost a full frame of delay, it is possible to set apparent negative timing, making it look like the output occurs before the input, although delayed by 1 frame.

Frame Sync (ADC-8032B-S)

The **Frame Sync** mode makes it possible to use asynchronous sources. The output timing is generated entirely based on the external reference. Whether a synchronous or an asynchronous source is used, output timing is constant. The delay through the card will be the minimum latency (in the order of microseconds) to a full frame of delay.

Timing Modes

This section provides a summary of all Timing Modes.

Line Delay

Use when you do not have an S version and need constant delay through the card.

- Output timing based on input timing
- Ignores external reference
- Has the lowest minimum delay through the card
- Two-line output timing adjustment window

Line Sync

Use when you do not have an S version and need constant output timing even though input timing may change. **This is the recommended mode for the non-S version.**

- Output timing based on external reference (line by line only)
- If input sources are timed to be on the same line, the output timing will be constant.
- Keep input timing away from the threshold point.

Frame Delay

Use when you have an S version and need constant delay through the card.

- Output timing based on input timing.
- Ignores external reference.
- Has the lowest minimum delay through the card.
- Output timing adjustment window has infinite phasing over a full frame.

Frame Sync

Use when you have an S version and need constant output timing, or when the input is asynchronous to house reference.

- Input can be asynchronous.
- Output timing is constant, regardless of input timing.
- Output phasing is infinite over a full frame, and the delay through the card varies from the minimum processing delay up to the minimum processing delay plus a full frame.

Bank C-1: Timing Mode

Use the following steps to set the timing mode:

1. Select Bank C, and rotate **Function Select** to position 1.
2. Select the desired timing mode according to the following table.
 - Toggle **Mode Select** *up* to advance up the list.
 - Toggle **Mode Select** *down* to descend down the list.

Bank	Function Select	Mode Select	Heads-Up Display Label	Default
C	1	+ Frame Sync * Frame Delay * Line Sync - Line Delay	TIME MODE FS FD LS LD	LS (FS on S models)

* Indicates ADC-8032B-S only

Bank C-2: H Delay

Use the following steps to adjust the output's H Delay:

1. Select Bank C, and rotate **Function Select** to position 2.
2. Increase or decrease the H Delay as required:
 - Toggle **Mode Select** *up* to increase H Delay by half a pixel (one 27MHz-clock period) with each toggle.
 - Hold **Mode Select** *up* to increase H Delay continuously.
 - Toggle **Mode Select** *down* to decrease H Delay by half a pixel (one 27MHz-clock period) with each toggle.
 - Hold **Mode Select** *down* to decrease H Delay continuously.

Bank	Function Select	Mode Select	Heads-Up Display Label	Default
C	2	+ Increase - Decrease	H DELAY (#)	0

Please note the following important points regarding H Delay:

- If you cross over the maximum H Delay, the value returns to 0 (zero) and the V Delay value increments by 1.
- Crossing the minimum delay returns the H Delay value to 1715 (NTSC or PAL-M) or 1725 (PAL-B or PAL-N) and decrements the V Delay value by 1.

Note

Crossing from 0 to maximum or from maximum to 0 will affect the **V Delay** setting in Bank C-4.

- Sub-pixel timing adjustments can be made using the **RV1 Fine Phase Adjust** potentiometer on the front edge of the card. Turning the pot clockwise increases delay, whereas turning it counter-clockwise decreases the delay. The range is approximately ± 20 ns, which is slightly longer than the step size of the H Delay function.

Bank C-3: H Reset

Use the following steps to reset just the H Delay value to 0 (zero). This function is particularly useful if your adjustment range is far off the mark, or if you simply want to quickly return to zero.

1. Select Bank C, and rotate **Function Select** to position 3.
2. Reset H Delay as required:
 - Toggle **Mode Select** *up* to reset H Delay to 0.

Bank	Function Select	Mode Select	Heads-Up Display Label	Default
C	3	+ Zero - No action	H RESET ZERO	N/A

Bank C-4: V Delay

Use the following steps to adjust the output's V Delay:

1. Select Bank C, and rotate **Function Select** to position 4.
2. Increase or decrease the V Delay as required:
 - Toggle **Mode Select** *up* to increase V Delay by one line, and wrap around from the maximum to 0 if necessary.
 - Hold **Mode Select** *up* to increase V Delay continuously.
 - Toggle **Mode Select** *down* to decrease V Delay by one line, and wrap around from 0 to the maximum if necessary.
 - Hold **Mode Select** *down* to decrease V Delay continuously.

Bank	Function Select	Mode Select	Heads-Up Display Label	Default
C	4	+ Increase - Decrease	V DELAY (#)	0

Bank C-5: V Reset

Use the following steps to reset just the V Delay value to 0 (zero).

1. Select Bank C, and rotate **Function Select** to position 5.
2. Reset V Delay as required:
 - Toggle **Mode Select** *up* to reset V Delay to 0.

Bank	Function Select	Mode Select	Heads-Up Display Label	Default
C	5	+ Zero - No action	V RESET ZERO	N/A

Bank C-6: Set Minimum Delay

Use the following steps to reset both the H Delay and V Delay values to 0 (zero).

1. Select Bank C, and rotate **Function Select** to position 6.
2. Reset all delays as required:
 - Toggle **Mode Select** *up* to reset H Delay and V Delay to 0.

Bank	Function Select	Mode Select	Heads-Up Display Label	Default
C	6	+ Zero - No action	MIN DEL ZERO	N/A

Bank C- 7: Input Mode

The **Input Mode** function selects what type of video is being input. The choices are:

- **Standard** – standard
- **VTR** – input signals that do not have a stable timebase, such as VTRs

When VTR is selected as the video Input Mode, an external reference should be used to reclock the output signal to the house reference.

Use the following steps to set the Input Mode:

1. Select Bank C, and rotate **Function Select** to position 7.
2. Select the desired Input mode according to the following table.
 - Toggle **Mode Select** *up* to set VTR mode
 - Toggle **Mode Select** *down* to set STANDARD mode.

Bank	Function Select	Mode Select	Heads-Up Display Label	Default
C	7	+ VTR mode - STANDARD mode	IN MODE VTR STAND	STAND

Note

When the **Input Mode** is set to **VTR Mode**, the **Hotswitch Mode** will be forced OFF.

Bank C-8: Freeze Mode

The input image can be frozen (ADC-8032B-S only) if any of the following conditions occur:

- The user selects Manual Freeze (**Forced Freeze**, Bank C, position 9)
- There is a loss of input signal (**Input Loss Mode**, Bank C, position A)
- A hotswitch occurs (**Hotswitch Mode**, Bank C, position B)

The **Freeze Mode** function allows you to set what will be output when a freeze occurs: the last Field 1, the last Field 2, or the last Full Frame. Use the following steps to set the freeze mode:

2. Select Bank C, and rotate **Function Select** to position 8.
3. Select the desired mode according to the table below:
 - Toggle **Mode Select** *up* to advance up the list.
 - Toggle **Mode Select** *down* to descend down the list.

Bank	Function Select	Mode Select	Heads-Up Display Label	Default	
C	8	+	Frame	FRZ MODE	FLD 1
			Field 2	FRAME	
		-	Field 1	FLD 2 FLD 1	

Bank C-9: Forced Freeze

The output can be manually frozen (ADC-8032B-S only) using the **Forced Freeze** mode. When enabled, the freeze will use either field 1, field 2 or the entire frame (as determined by the **Freeze Mode** function).

Use the following steps to enable or disable the Forced Freeze mode:

1. Select Bank C, and rotate **Function Select** to position 9.
2. Select the desired mode:
 - Toggle **Mode Select** *up* to freeze the image. The **FREEZE** LED is on.
 - Toggle **Mode Select** *down* to un-freeze the image, and allow input video to pass through. The **FREEZE** LED is off.

Bank	Function Select	Mode Select	Heads-Up Display Label	Default	
C	9	+	Freeze	FREEZE	PASS
		-	Pass Through	FORCE PASS	

Bank C-A: Input Loss Mode

The **Input Loss Mode** function selects what type of video appears at the system's four outputs when the input signal is lost or invalid. These choices are available:

- **Black** - SDI black.
- **No Output** - flat line, no signal present.
- **Freeze** - the last valid image is automatically frozen (**ADC-8032B-S** only). The freeze is determined by the **Freeze Mode** function.

Use the following steps to set the Input Loss Mode:

1. Select Bank C, and rotate **Function Select** to position A.
2. Select the desired mode according to the table below:
 - Toggle **Mode Select** *up* to advance up the list.
 - Toggle **Mode Select** *down* to descend down the list.

Bank	Function Select	Mode Select	Heads-Up Display Label	Default	
C	A	+	Freeze	IN LOSS FREEZE	BLACK
			No Output	NO OUTPUT	
		-	Black	BLACK	

Important

It is recommended that the **Hotswitch Mode** and **Input Loss Mode** have the same setting: both set to freeze, or both set to black. There is circuitry in the sync stripper that removes unwanted impulses to make the circuit more noise tolerant. During a hotswitch, this could cause the **ADC-8032B** to interpret the signal has been lost. Since the Input Loss mode overrides the Hotswitch mode setting, having one set to freeze and the other set to black could lead to a momentary glitch on the output.

Bank C-B: Hotswitch Mode

The **ADC-8032B** uses a phase-locked-loop (PLL) to synchronize its pixel clock to the incoming signal's line rate. Because of this, any disturbance to the incoming line rate, such as an untimed switch outside the lock window of the PLL, will cause the PLL to lose lock. It can take several fields before the PLL can regain lock, and until it does so, the decoder cannot properly decode the incoming video. The result is that untimed switches will result in a disruption to the output video.

To mask this disruption, a hotswitch mode was created. This is accomplished by momentarily freezing the last good frame, or momentarily going to black while the untimed switch occurs. Going to black is recommended since the output can be forced to black as soon as the hotswitch condition is detected. Freezing must wait until the next field, in which case a single corrupted field could get through to the output.

In Frame Sync, the output timing will be undisturbed as it is based on the external reference. In Line Sync mode, as long as the input sources are on the same line relative to the external reference, and they do not cross the threshold point (see Bank C-1 Timing Mode for details on the threshold point), then the output timing will also be undisturbed. In all other cases, the output timing will be disturbed any time an untimed switch is made at the input of the **ADC-8032B**. This function *sets* the mode or disables it. Three choices are available:

- **Off** - disables the Hotswitch Mode.
- **Black** - the output momentarily cuts to black when an untimed switch is made at the input.
- **Freeze** - (**ADC-8032B-S** only) the last valid image is momentarily frozen. The freeze will affect either field 1, field 2 or the entire frame (as determined by the **Freeze Mode** function).

In either case, the output returns once the card has resynchronized to the input. Use the following steps to set the Hotswitch Mode:

1. Select Bank C, and rotate **Function Select** to position B.
2. Select the desired mode according to the table below:
 - Toggle **Mode Select** *up* to advance up the list.
 - Toggle **Mode Select** *down* to descend down the list.

Bank	Function Select	Mode Select	Heads-Up Display Label	Default
C	B	+ Freeze Black - Off	HOTSW MD FREEZE BLACK OFF	OFF

Note

Freeze hotswitching is not supported in **Line Delay**, **Line Sync** and **Frame Delay** timing modes. If one of these timing modes is selected and freeze hotswitching is enabled, the hotswitch will go to black instead.

Important

Because output timing is disrupted in **Line Delay** and **Frame Delay** modes, hotswitching is not guaranteed to go completely black. These two timing modes should never be used if the input source is switched while on air, since the output timing will be affected, and this could affect equipment downstream of the **ADC-8032B**.

Important

It is recommended that the **Hotswitch Mode** and **Input Loss Mode** be set the same with either: both set to freeze, or both set to black. There is circuitry in the sync stripper that removes unwanted impulses to make the circuit more noise tolerant. During a hotswitch, this could cause the **ADC-8032B** to interpret the signal has been lost. Since the Input Loss mode overrides the Hotswitch mode setting, having one set to freeze and the other set to black could lead to a momentary glitch on the output.

Important

Time-based error-prone signals such as from a VTR will falsely trigger the hotswitch. Thus if the **Input Mode** is set to VTR it forces the **Hotswitch Mode** to OFF.

Bank C-C: Forced Black

This selection forces the output to black. Use the following steps to enable or disable the Forced Black mode:

1. Select Bank C, and rotate **Function Select** to position C.
2. Select the desired mode according to the table below:
 - Toggle **Mode Select** *up and hold for one second* to force the output to black.
 - Toggle **Mode Select** *down* to disable the Forced Black mode.

Bank	Function Select	Mode Select	Heads-Up Display Label	Default
C	C	+ (h) On - Off	FRCD BLK ON OFF	OFF

Bank C-D: Forced Mono

This selection forces the output to monochrome (SDI). Use the following steps to enable or disable the Forced Monochrome mode:

1. Select Bank C, and rotate **Function Select** to position D.
2. Select the desired mode according to the table below:
 - Toggle **Mode Select** *up and hold for one second* to force the output to monochrome.
 - Toggle **Mode Select** *down* to disable the Forced Monochrome mode.

Bank	Function Select	Mode Select	Heads-Up Display Label	Default
C	D	+ (h) On - Off	FRCD MONO ON OFF	OFF

SMPTE 269M Fault Reporting

In This Chapter

This chapter contains the following sections:

- Overview
- Jumper Setup
- Frame Connections
- Details

Overview

The SMPTE 269M Fault Reporting system, also known as an SMPTE “alarm”, provides indication if one or more frame modules encounter a fault or an abnormal condition. The ADC-8032B module provides a jumper to enable SMPTE-269M fault reporting. The card connects by means of an internal interface circuit to an auxiliary telco connector on RossGear 8000 series frames. When the frame connection is interfaced with a customer-designed system of LEDs or audible alarms, faults can be traced to a specific frame when a card fault occurs within that frame.

The following diagram illustrates a general arrangement for SMPTE 269M alarm reporting:

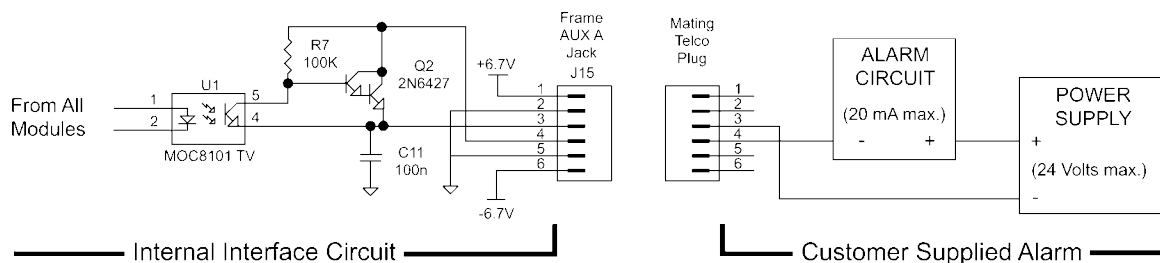

Figure 6. SMPTE 269M Alarm Reporting: Internal interface and typical connections

Jumper Setup

If fault reporting for the ADC-8032B is desired, use jumper **JP5 - 269M Fault Report** to set up the card.

1. To access the jumper, remove the card from the frame by pressing down the white card ejector tab and pulling the card from the frame slot.
2. Observing all static discharge and handling precautions, place the card with the component side facing up on a clean flat surface.
3. To enable SMPTE fault reporting, set jumper **JP5** to **EN** position. See the Jumper Setup section in Chapter 2 “**Installation and Setup**”.
4. To disable SMPTE fault reporting, set jumper **JP5** to **DIS** position. See the Jumper Setup section in Chapter 2 “**Installation and Setup**”.
5. To return the card to the designated frame installation slot, hold the ADC-8032B card by the edges and carefully align the card edges with the slots in the frame. Then fully insert the card into the frame until the rear connection plug is properly seated.

Frame Connections

The SMPTE 269M Fault Reporting connection on RossGear 8000 series frames is provided by the auxiliary telco connector, **AUX A**, for interfacing with a customer-designed alarm system.

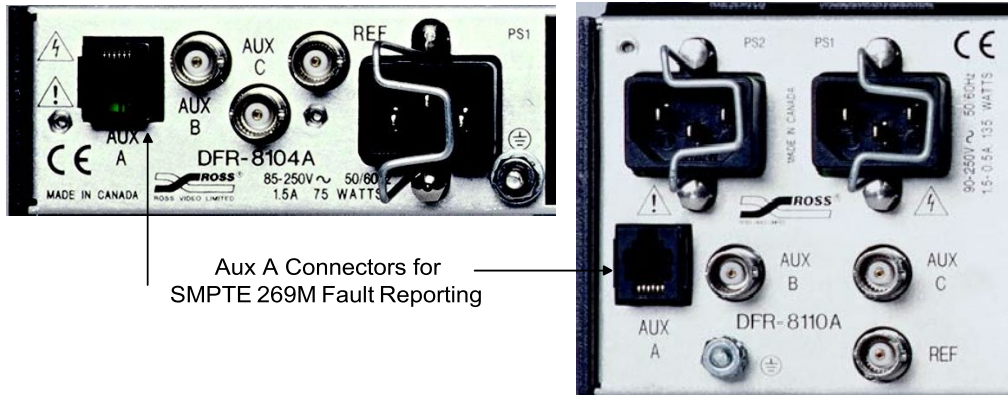

Figure 7. SMPTE 269M Alarm Reporting Frame Connections

Connect the frame’s **AUX A** connector to your facility’s SMPTE alarm circuit.

Details

The fault report contacts are closed when the card detects an internal failure or a power loss condition. The fault report will pulse off for 1 to 2 ms about every 16ms if the input signal is low or missing.

Some internal failures are:

- Failure of the card to initialize
- Failure in the fault reporting circuitry
- Failure to detect a valid analog input signal to the card

For additional information on alarm system design, refer to the SMPTE document *ANSI/SMPTE 269M - 1999*.

Frame Synchronizer Upgrade

In This Chapter

This chapter describes instructions required to properly upgrade your ADC-8032B decoder for full frame synchronization operation (ADC-8032B-S functionality). To order a Frame Synchronizer Upgrade kit, contact Ross Video Customer Service.

This chapter contains the following sections:

- Equipment Supplied
- Record Settings
- Software Upgrade Procedure
- Firmware Upgrade Procedure
- Confirm Upgrade

Equipment Supplied

Your Frame Synchronizer Upgrade kit contains:

- 1 ADC-8032B User Manual
- 1 software upgrade chip
- 1 chip remover tool

Optionally, your Frame Synchronizer Upgrade kit may also contain:

- 1 firmware upgrade chip
- 1 2-pin jumper shunt

Record Settings

Before performing the upgrade, use the following tables to record the configurations and settings you have selected in bank A, B, and C of the 8032B. The card must be reconfigured after the upgrade is complete.

Table 6. Function Select: Bank A Function Table

SW1 Function Select	Function	Bank A Settings
0	Bank Select	
1	Heads-Up Display	
2	N/A	
3	N/A	
4	Decode	
5	Test Pattern	
6	N/A	
7	N/A	
8	Video Gain	
9	Black Level Offset	
A	Chroma Gain	
B	Hue	
C	C _B Gain	
D	AGC	
E	Factory Defaults	
F	Switch Access	

Table 7. Function Select: Bank B Function Table

SW1 Function Select	Function	Bank B Settings
0	Bank Select	
1	Setup	
2	N/A	
3	VI Blanking	
4	VI End	
5	SuperBlack	
6	V Bit Lock	
7	N/A	
8	N/A	
9	N/A	
A	N/A	
B	N/A	
C	N/A	
D	N/A	
E	N/A	
F	N/A	

Table 8. Function Select: Bank C Function Table

SW1 Function Select	Function	Bank C Settings
0	Bank Select	
1	Timing Mode	
2	H Delay	
3	H Reset	
4	V Delay	
5	V Reset	
6	Set Min. Delay	
7	Input Mode	
8	Freeze Mode	
9	Forced Freeze	
A	Input Loss Mode	
B	Hotswitch Mode	
C	Forced Black	
D	Forced Mono	
E	N/A	
F	N/A	

Software Upgrade Procedure

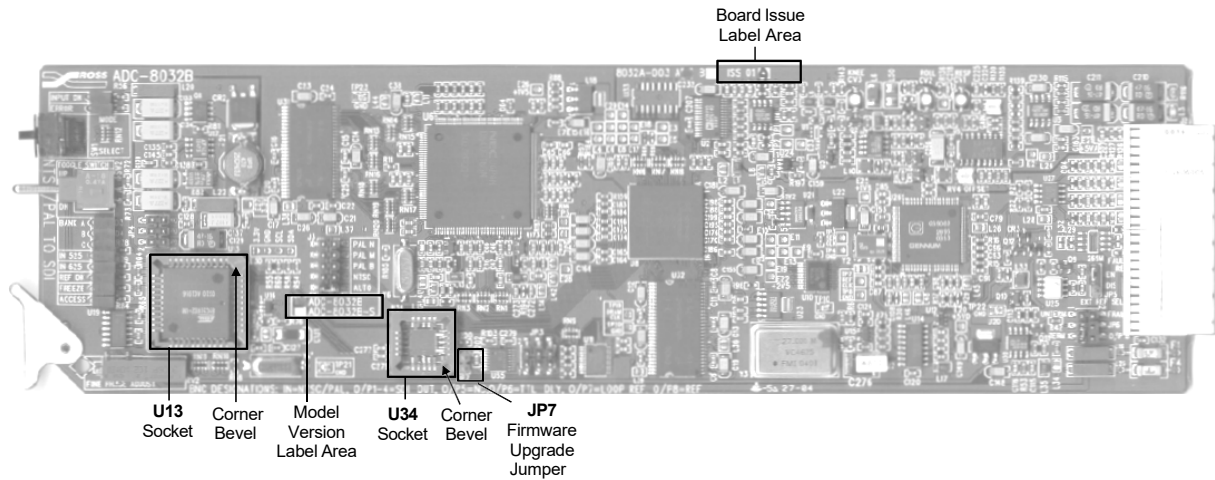

Figure 8. Frame Synchronizer Socket and Label Location

1. Remove the card from the mounting frame.
2. Refer to Figure 8 and the card labeling to locate the existing IC chip in socket **U13**.
3. Insert the supplied IC chip removal tool, with the toothed-end inward, in one of the corner slots of the **U13** socket.

Important

Do not press the tool too far into the slot or you may catch against the mounting socket's frame, where it connects to the card itself. Excessive prying may damage the socket frame or the card or both. Follow the instructions included with the chip extraction tool.

4. Alternating between corners, gently pry up the chip from the socket.
5. Store the old chip in a labeled static free container.
6. Carefully remove the new chip from the packaging. The chip and the socket each have one beveled corner for alignment purposes.
7. Align the new chip over the socket with the beveled corners together and the label facing up. Text direction may vary.
8. Gently and firmly press the chip into the socket.
9. Proceed to the Firmware Upgrade Procedure on the following page.

Firmware Upgrade Procedure

The firmware upgrade is not required to convert an ADC-8032B to an ADC-832B-S. However, depending on the firmware issue loaded on your existing ACD-8032B, the Ross Video Customer Service team may provide one in the upgrade kit.

The following instructions apply only if the firmware upgrade chip is in your upgrade kit.

1. Refer to Figure 8 and the card labeling to locate socket **U34**.
2. Do one of the following:
 - If there is a chip in the socket, continue on from step 3.
 - If the socket is empty skip to step 6.
3. Insert the supplied IC chip removal tool, toothed-end inward, in one of the corner slots of the **U34** socket.

Important

Do not press the tool too far into the slot or you may catch against the mounting socket's frame, where it connects to the card itself. Excessive prying may damage the socket frame or the card or both. Follow the instructions included with the chip extraction tool

4. Alternating between corners, gently pry up the chip from the socket.
5. Store the old chip in a labeled static free container.
6. Carefully remove the new chip from the packaging. The chip and the socket each have one beveled corner for alignment purposes.
7. Align the new chip over the socket with the beveled corners together and the label facing up. Text direction may vary.
8. Gently and firmly press the chip into the socket.
9. Install the supplied jumper shunt on **JP7**.
10. Reinsert the card into the frame.
11. Confirm your upgrade with the following procedure.

Confirm Upgrade

With the card installed in the frame and powered up:

1. Select Bank A, and rotate **Function Select** to position F.
2. Hold **Mode Select** *down* for one second to unlock switch access.
The **ACCESS** LED is on.
3. Rotate **Function Select** to position 1.
4. Hold **Mode Select** *up* for one second to enable the Heads Up display.
5. Rotate **Function Select** to position 0.
6. Toggle **Mode Select** *down* to position C.
7. Hold **Mode Select** *down* for several seconds to display the card model installed.
On the Heads Up display, “**ADC-8032B-S**” is displayed, indicating that the upgrade was successful.
8. Reconfigure the card settings from the tables in the Record Settings section.
9. Refer to the relevant chapters in this user manual for information on the operation of the full frame synchronizer.

If you have any questions or encounter any problems, please contact Ross Video Customer Service at (613) 652-4886.

Specifications

In This Chapter

This chapter contains the Technical Specifications table.

Technical Specifications

Table 9. Technical Specifications

Category	Parameter	Specification
Composite Video Input	Signal Standards Accepted	NTSC, PAL-B, PAL-M, PAL-N
	Number of Inputs	1
	Composite Video	1V p-p nominal
	Input Impedance	75Ω terminating
	Return Loss	>42dB to 6MHz
	Common Mode Rejection	>58dB @ 50/60Hz
Component SDI Output	Signal Standards	SMPTE 259M-C, 270Mb/s 525/625 lines, 10 bits
	Number of Outputs	4
	Output Return Loss	>17dB to 270MHz
	Signal Level	800mV ± 10%
	DC Offset	<100mV
	Rise and Fall Time	>800pS (20 - 80%, ±15%)
	Overshoot	<10% typical
Analog Reference	Signal Standards Accepted	NTSC, PAL, PAL-M, PAL-N
	Number of Inputs	1
	Input Impedance	75Ω
	Return Loss	>35dB to 5MHz
Performance	Luminance Frequency Response	± 0.25dB to 5MHz, < -0.8dB @ 5.75MHz
	RMS SNR, Luma Channel	> 56dB to 5.5MHz, unweighted
	RMS SNR, Chroma Channel	> 56dB to 5.5MHz, unweighted
	H and V phasing	Infinite with frame sync, 2 lines without frame sync
Minimum Delay in Line/Frame Delay Mode	Minimum Delay	NTSC: 1 Line + 52.1μS PAL: 1 Line + 15.7μS
Power Consumption	Total	4.2W
Tracking Delay Pulse	ADC-8032B	up to 2 video lines
	ADC-8032B-S	up to 2 video fields

Specifications are subject to change without notification

Service Information

In This Chapter

This chapter contains the following sections:

- Troubleshooting Checklist
- Warranty and Repair Policy

Troubleshooting Checklist

Routine maintenance to this RossGear product is not required. In the event of problems with your ADC-8032B, the following basic troubleshooting checklist may help identify the source of the problem. If the module still does not appear to be working properly after checking all possible causes, please contact your Ross Video products distributor, or the Ross Video Technical Support department at the numbers listed under the “Contact Us” section at the end of this manual.

1. **Visual Review** – Performing a quick visual check may reveal many problems, such as connectors not properly seated or loose cables. Check the module, the frame, and any associated peripheral equipment for signs of trouble.
2. **Power Check** – Check the power indicator LED on the distribution frame front panel for the presence of power. If the power LED is not illuminated, verify that the power cable is connected to a power source and that power is available at the power main. Confirm that the power supplies are fully seated in their slots. If the power LED is still not illuminated, replace the power supply with one that is verified to work.
3. **Reseat the Card in the Frame** – Eject the card and reinsert it in the frame.
4. **Check Control Settings** – Refer to the Installation and Operation sections of the manual and verify all user-component settings including correct BNC designations.
5. **Input Signal Status** – Verify that source equipment is operating correctly and that a valid signal is being supplied.
6. **Output Signal Path** – Verify that destination equipment is operating correctly and receiving a valid signal.
7. **Module Exchange** – Exchanging a suspect module with a module that is known to be working correctly is an efficient method for localizing problems to individual modules.

Warranty and Repair Policy

The RossGear ADC-8032B is warranted to be free of any defect with respect to performance, quality, reliability, and workmanship for a period of **FIVE (5)** years from the date of shipment from our factory. In the event that your RossGear ADC-8032B proves to be defective in any way during this warranty period, Ross Video Limited reserves the right to repair or replace this piece of equipment with a unit of equal or superior performance characteristics.

Should you find that this RossGear ADC-8032B has failed after your warranty period has expired, we will repair your defective product for as long as suitable replacement components are available. You, the owner, will bear any labor and/or part costs incurred in the repair or refurbishment of said equipment beyond the FIVE (5) year warranty period.

In no event shall Ross Video Limited be liable for direct, indirect, special, incidental, or consequential damages (including loss of profits) incurred by the use of this product. Implied warranties are expressly limited to the duration of this warranty.

This RossGear ADC-8032B Analog Composite to SDI Video Decoder User Manual of our Digital Products line provides all pertinent information for the safe installation and operation of your RossGear Product. Ross Video policy dictates that all repairs to the RossGear ADC-8032B are to be conducted only by an authorized Ross Video Limited factory representative. Therefore, any unauthorized attempt to repair this product, by anyone other than an authorized Ross Video Limited factory representative, will automatically void the warranty. Please contact Ross Video Technical Support for more information.

In Case of Problems

Should any problem arise with your RossGear ADC-8032B, please contact the Ross Video Technical Support Department. (Contact information is supplied at the end of this publication.)

A Return Material Authorization number (RMA) will be issued to you, as well as specific shipping instructions, should you wish our factory to repair your RossGear ADC-8032B. A temporary replacement module, if required, will be made available at a nominal charge. Any shipping costs incurred, will be the responsibility of you, the customer. All products shipped to you from Ross Video Limited, will be shipped collect.

The Ross Video Technical Support Department will continue to provide advice on any product manufactured by Ross Video Limited, beyond the warranty period without charge, for the life of this equipment.

Ordering Information

In This Chapter

This chapter contains ordering information for the ADC-8032B and related products.

ADC-8032B and Related Products

Standard Equipment

- **ADC-8032B** Analog Composite to SDI Video Decoder
- **ADC-8032B-S** Analog Composite to SDI Video Decoder with Frame Synchronizer
- **8032BD-004** Analog Composite to SDI Video Decoder User Manual

Optional Equipment

- **8032BD-004** Analog Composite to SDI Video Decoder User Manual (additional User Manual)
- **FSU-8032B** Frame Synchronizer Upgrade (Upgrade a standard ADC-8032B to a ADC-8032B-S)
- **DFR-8104A** Digital Products Frame and Power Supply (PS-8102) (1RU, holds 4 modules, includes 1 power supply)
- **DFR-8104A-C** Digital Products Frame with Cooling Fan Module and Power Supply (PS-8102) (1RU, holds 4 modules, includes 1 power supply)
- **DFR-8110A** Digital Products Frame and Power Supply (PS-8102) (2RU, holds 10 modules, includes 1 power supply)
- **DFR-8110A-C** Digital Products Frame with Cooling Fan Module and Power Supply (PS-8102) (2RU, holds 10 modules, includes 1 power supply)

Your **ADC-8032B Analog Composite to SDI Decoder** is part of the RossGEAR family of products. Ross Video offers a full line of RossGEAR terminal equipment including distribution, conversion, monitoring, synchronizers, encoders, decoders, keyers, switchers, as well as analog audio and video products.

Notes:

Notes:

Contact Us

Contact our friendly and professional support representatives for the following:

- Name and address of your local dealer
- Product information and pricing
- Technical support
- Upcoming trade show information

PHONE	General Business Office and Technical Support	613 • 652 • 4886
	After-hours Emergency	613 • 652 • 4886 ext. 333
	Fax	613 • 652 • 4425
E-MAIL	General Information	solutions@rossvideo.com
	Technical Support	techsupport@rossvideo.com
POSTAL SERVICE	Ross Video Limited	8 John Street, Iroquois, Ontario, Canada K0E 1K0
	Ross Video Incorporated	P.O. Box 880, Ogdensburg, New York, USA 13669-0880

Visit Us

Please visit us at our website for:

- Company information
- Related products and full product lines
- On-line catalog
- Trade show information
- News
- Testimonials

www.rossvideo.com
