

READ THIS FIRST!

Save Time and Avoid Damage!

We realize that you will want to start installing your new equipment right away. But, you will save time and avoid costly damage by taking a few moments to review the following helpful information before you proceed.

1. Installation and Cable Connections

Before turning the power on, consult the "Installation" section of this manual to obtain specific advice about cable connections, switch settings and jumper configurations.

2. Operation

See the "Operation" section for proper use of your new equipment.

3. Calibration

All Ross Video Terminal Equipment is factory calibrated. Adjustment of sealed calibration components or any repairs to this unit, are to be performed by an authorized Ross Video technician. Unauthorized repairs will void your Warranty.

In Case of Problems

If you encounter any problems with the installation of this unit, please call our Customer Service Department at (613) 652-4886, 24 hours a day, 7 days a week.

Advice is available, without charge, for the life of this equipment, not just for the warranty period.

Section 6

ADA 7554

Stereo Distribution Amplifier

Issue 2 & 3

ADA-7554 • Audio Distribution Amplifier – User Manual

- Ross Part Number: **AM-7554-02/03**
- Document Issue: **2/3**
- Printing Date: March 2, 2000. Printed in Canada.

The information contained in this guide is subject to change without notice or obligation.

Copyright

© 2000 Ross Video Limited. All rights reserved.

Contents of this publication may not be reproduced in any form without the written permission of Ross Video Limited. Reproduction or reverse engineering of copyrighted software is prohibited.

Notice

The material in this guide is furnished for informational use only. It is subject to change without notice and should not be construed as commitment by Ross Video Limited. Ross Video Limited assumes no responsibility or liability for errors or inaccuracies that may appear in this manual.

Trademarks

-  is a registered trademark of Ross Video Limited.
- Ross, ROSS, ROSS® and RossGear are registered trademarks of Ross Video Limited.
- All other product names and any registered and unregistered trademarks mentioned in this guide are used for identification purposes only and remain the exclusive property of their respective owners.

Company Address



Ross Video Limited
8 John Street
Iroquois, Ontario, K0E 1K0
Canada

Ross Video Incorporated
P.O. Box 880
Ogdensburg, New York
USA 13669-0880

General Business Office: (+1) 613 • 652 • 4886
Fax: (+1) 613 • 652 • 4425
Customer Service: (+1) 613 • 652 • 4886

E-mail (Customer Support): tech-support@hq.rossvideo.com
E-mail (General Information): solutions@rossvideo.com
Website: <http://www.rossvideo.com>

After hours emergency: (+1) 613 • 652 • 4886, ext. 333

ADA 7554 BLOCK DIAGRAM

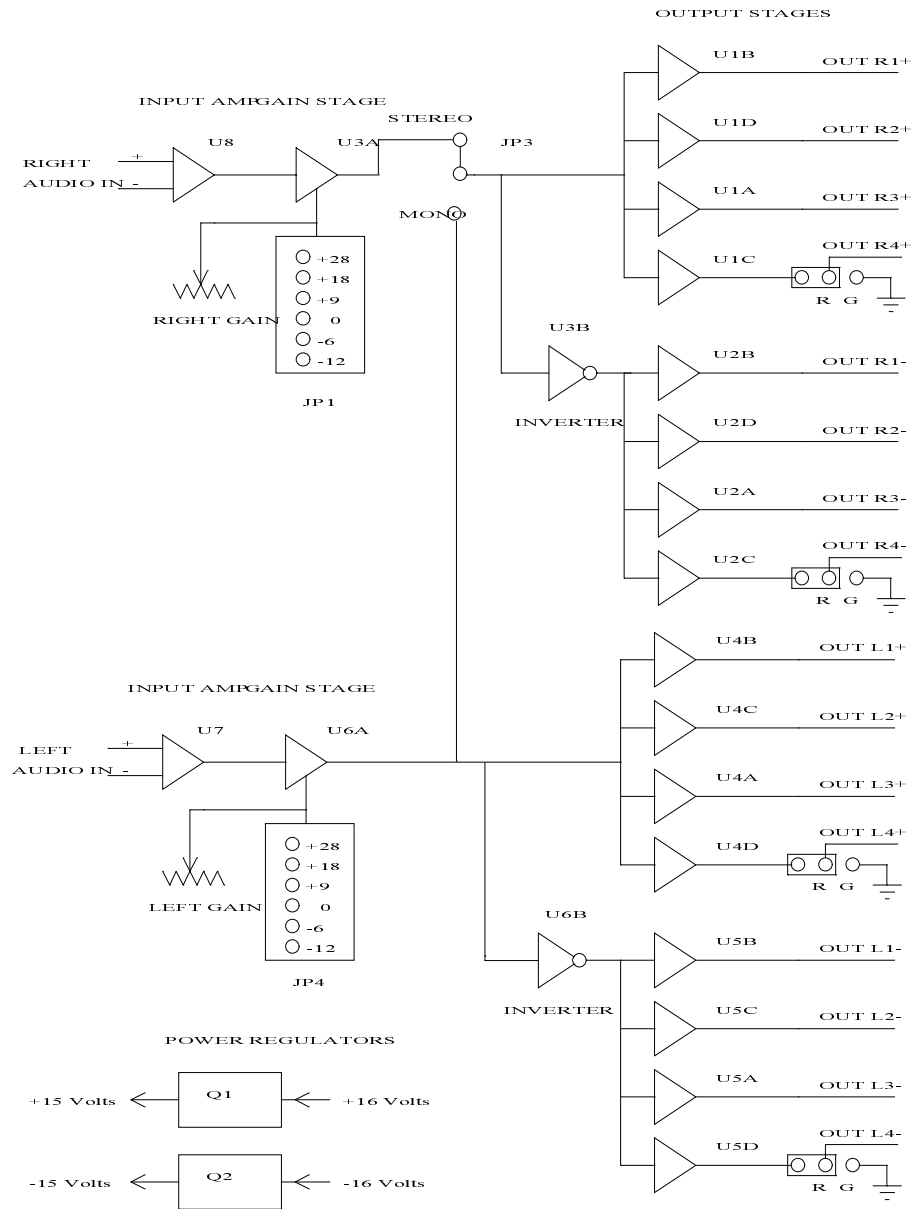

Introduction

The Ross ADA-7554 Stereo Distribution Amplifier provides a means of amplifying and distributing program-level stereo audio with virtually no loss of quality. Use of the latest types of integrated circuits which are developed specifically suited to professional audio applications assures a very low level of distortion and noise.

The circuit board contains two identical amplifiers which can be used for stereo distribution or as two independent four-output mono amplifiers. A jumper plug enables the amplifiers to be operated as a single eight-output amplifier.

Installation

The card TRAY TYPE jumper (JP2) settings must be set before use. All jumper plugs must be set in a vertical row corresponding with the tray type designation as follows:

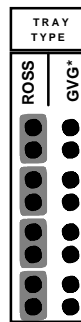

Ross Trays

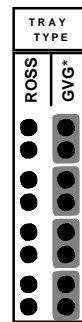

GVG* Trays

CAUTION:

If JP2 is not set correctly for a GVG tray, damage to the integrated circuits may occur.

Operation

Controls are provided for setting the gain of each amplifier channel.

The GAIN jumper plugs are to be set for the desired gain range. In most installations they will be set to the 0 dB position to obtain unity gain.

The GAIN potentiometer provides a fine control of the gain and has a range of +/- 6dB.

There is no need to set the common mode BAL adjustment as it has been precisely factory pre-set and sealed. This amplifier incorporates an advanced type of input stage that does not have to be balanced for each installation.

Jumper JP3 is normally set to the STEREO position. Setting it to MONO configures the board as a single eight-output mono amplifier.

Jumper JP2 is set for the type of card tray used. When set to the ROSS position, four sets of stereo outputs are available. When set to the GVG position, only three sets of outputs are available.

*GVG is a trademark of The Grass Valley Group Inc.

Circuit Description

Both the right channel and left channel employ identical circuits so only the right channel description follows.

The input stage, U8, performs the function of converting the balanced input signal into an unbalanced (single ended) signal for further processing.

This stage is unique because it functions exactly as if the amplifier had a floating transformer input. This means that it responds only to the voltage difference between the two input lines and ignores any imbalance to ground. This gives the distribution amplifier the very desirable ability to accept any out-of-balance input signal and produce a perfectly balanced output. As a consequence, it also has an exceptional ability to reject common mode hum and noise over the whole audio band.

The input circuit includes diodes to protect the amplifier against damaging input noise spikes.

The amplifier gain is provided by circuit U3A. JP1 selects the desired gain range and RV1 provides vernier gain adjustment.

The positive line outputs are driven by unity-gain stage U1. These circuits are designed to be very stable and not oscillate at any normal line load. The negative output stage U2 is driven by unity-gain inverter U3B.

The power input voltage of approximately +/- 16 volts is reduced to +/- 15 volts by filtering circuits Q1 and Q2. This lower voltage powers the input and gain stages while the output stages are fed directly from the power supply.

Alignment

The only alignment controls provided are for balancing the common-mode rejection of the input amplifiers. To adjust the R BAL control, make the indicated connections to the terminal block associated with the particular amplifier.

NOTE:

Because this control has been precisely calibrated at the factory, it must not be adjusted unless U8 or U7 have been replaced.

1. Place the amplifier on the extender board.
2. Use a short jumper wire to connect the tray R INPUT plus and minus terminals together.
3. Connect an audio generator between either tray R input and ground. Set the generator frequency to 1 KHz and output level to +20 dBu.
4. Connect a balanced-input sensitive audio level meter or distortion analyser to a balanced pair of amplifier outputs.
5. With the output level meter set to the most sensitive scale, adjust the R BAL potentiometer to obtain the lowest possible output level. It should be possible to obtain an output level of at least -80 dBu. (110dB below +20 dBu). Seal the pot.
6. Proceed in a similar manner to set the L BAL pot.
7. Disconnect the test set up.

Specifications

ADA-7554 Stereo Audio Distribution Amplifier

Input	Input Impedance	>35K ohms, balanced
	Max Input Level	+34 dBu [+30 dBm]
	Common Mode Rejection	>100 dB @ 60 Hz >80 dB @ 20 KHz
Output	Number of Outputs	4 Stereo outputs, jumper selectable to 8 mono outputs
	Max Output Level	+28 dBu [+24 dBm]
	Output Impedance	48 ohms, [600 ohms]
	Output Isolation	>70 dB
Performance	S/N Ratio	>100 dB (unity gain) relative to +8 dBu
	Gain Range	-6 to +34 dB (± 6 dB fine adjustment)
	Frequency Response	+/- 0.02 dB 20 Hz to 20 KHz
	Total Harmonic Distortion + Noise	<0.002% [0.007%]
	Intermodulation	<0.0015% [0.006%] (SMPTE)
	Crosstalk between Amplifiers	>100 dB
	Interchannel Crosstalk	>90 dB
	Power Consumption @ +8 dBu output	0.9 W [3.1 W]
<p>All tests performed at +18 dBu and cover 20 Hz to 20 KHz unless otherwise specified. All measurements made with an Audio Precision System One test set. Performance of the 600 ohm version is similar, except where indicated [].</p>		

ADA-7554 Bill of Materials

7554A-001A Issue 2 & 3

Item	QTY	REF	Part	Description	Part Number
1	2	R34,R52	NVR	NO VALUE RESISTOR 5%	-----
2	16	R1,R3,R5,R7,R20,R22,R24, R26,R39,R40,R42,R45,R59, R61,R63,R65	NVR 1%	NO VALUE RESISTOR 1%	-----
3	2	TP4,TP5	NVTP	NO VALUE TEST POINT	-----
4	2	C19,C20	6p8	CAPACITOR CERAMIC 100V 2% 6p8	200-680
5	2	C18,C10	22p	CAPACITOR CERAMIC 100V 2% 22p	201-220
6	4	C2,C6,C9,C25	47p	CAPACITOR CERAMIC 100V 2% 47p	201-470
7	8	C1,C4,C7,C8,C11,C13,C17, C26	100n	CAPACITOR GLASS 100n	225-100
8	4	C3,C5,C12,C14	100u 250-005	CAPACITOR TANTALUM 6.3V 100u	250-005
9	2	C23,C21	47u	CAPACITOR TANTALUM 16V 47u	250-006
10	4	C15,C16,C22,C24	6u8	CAPACITOR TANTALUM 25V 6u8	250-008
11	1	J1	311-035	CONNECTOR 2X25P PCB MNT 90 DEG	311-035
12	8	CR1,CR2,CR3,CR4,CR5,CR6, CR7,CR8	1N4148	DIODE SIGNAL GP 1N4148	360-005
13	1	MP1	365-001	PCB EJECTOR	365-001
14	2	JP4,JP1	403-004-12	HEADER 12 PIN 2 ROW MALE PL.23 BL.1 LL.1	403-004-12
15	1	JP2	403-004-16	HEADER 16 PIN 2 ROW MALE PL.23 BL.1 LL.1	403-004-16
16	1	JP3	403-013-03	HEADER 3 PIN 1 ROW MALE PL.23 BL.1 LL.1	403-013-03
17	2	U3,U6	NE5532N	INT-COMPENSATED DUAL LO-NOISE OP AMP	504-129
18	2	U7,U8	SSM-2143P	-6dB DIFFERENTIAL LINE RECEIVER	504-130
19	4	U1,U2,U4,U5	TLE2064CN	JFET-INPUT HIGH-OUT POWER QUAD OP AMP	504-155
20	7	JPPLUG1,JPPLUG2D, JPPLUG2C,JPPLUG2B, JPPLUG2A,JPPLUG3,JPPLUG4	603-005	JUMPER 2-POSITION LOW PROFILE	603-005
21	2	RV4,RV2	100R 1T	VARIABLE RESISTOR 1/4 DIA 1-TURN 100R	710-002
22	2	RV1,RV3	10K 720-002	VARIABLE RESISTOR 20-TURN 10K	720-002
23	1	PCB	7554-001-01	STEREO/MONO AUDIO AMP	7554-001-01
24	2	F1,F2	1R 1%	RESISTOR 1/4W 1% 1R	810-100
25	2	R54,R13	53R6 1%	RESISTOR 1/4W 1% 53R6	811-536
26	2	R55,R14	191R 1%	RESISTOR 1/4W 1% 191R	812-191
27	2	R56,R15	750R 1%	RESISTOR 1/4W 1% 750R	812-750
28	2	R77,R36	1K07 1%	RESISTOR 1/4W 1% 1K07	813-107
29	2	R35,R76	3K32 1%	RESISTOR 1/4W 1% 3K32	813-332
30	16	R2,R4,R6,R8,R21,R23,R25, R27,R41,R43,R44,R46,R60, R62,R64,R66	4K75 1%	RESISTOR 1/4W 1% 4K75	813-475
31	4	R18,R37,R58,R79	10K 1%	RESISTOR 1/4W 1% 10K	814-100
32	2	R51,R84	52K3 1%	RESISTOR 1/4W 1% 52K3	814-523
33	16	R9,R10,R11,R12,R28,R29, R30,R31,R47,R48,R49,R50, R67,R68,R69,R70	24R	RESISTOR 1/2W 5% 24R	825-240
34	2	R85,R74	47R	RESISTOR 1/2W 5% 47R	825-470
35	2	R38,R19	1K	RESISTOR 1/2W 5% 1K	827-100
36	2	R57,R16	1K5	RESISTOR 1/2W 5% 1K5	827-150
37	2	R80, R81	1K8	RESISTOR 1/2W 5% 1K8	827-180
38	2	R32,R75	2K7	RESISTOR 1/2W 5% 2K7	827-270
39	3	R71,R80,R82	4K7	RESISTOR 1/2W 5% 4K7	827-470
40	2	R17,R78	12K	RESISTOR 1/2W 5% 12K	828-120
41	2	R53,R33	20K	RESISTOR 1/2W 5% 20K	828-200
42	4	R72,R73,R83,R86	10K 0.5%	RESISTOR 1/4W 0.5% 10K	840-059
43	3	TP1,TP2,TP3	910-010	TEST POINT	910-010
44	1	Q1	2N3904	TRANSISTOR N-P-N	950-016
45	1	Q2	2N3906	TRANSISTOR P-N-P	950-018

ADA 7554-600

7554A -001A (600 ohm version)

Bill of materials same as per 7554A above with the following exceptions.

Item 1:	20K 1/2 W 5%	RESISTOR 1/2 5% 20K	827-200
Item 2:	4K75 1/4 W 1%	RESISTOR 1/4 W 1%	813-475
Item 33:	300R	RESISTOR 1/2 WF 5% 300R	826-300

Notes

Ross Gear Terminal Equipment • Warranty and Repair Policy

This **Ross Gear Terminal Equipment** product is warranted to be free of any defect with respect to performance, quality, reliability and workmanship for a period of **FIVE (5)** years from the date of shipment from our factory.

In the event that your **Ross Gear** product proves to be defective in any way during this warranty period, we will gladly repair or replace this piece of equipment with a unit of equal or superior performance characteristics.

Should you find that this **Ross Gear** product has failed after your warranty period has expired, we will repair your defective piece of equipment for as long as suitable replacement components are available. You, the owner, will bear any labour and/or component costs incurred in the repair or refurbishment of said equipment, beyond the **FIVE (5)** year warranty period.

Should your **Ross Gear** product be of our **Digital Terminal Equipment** product line, a power supply, or carries any surface mount devices, proves to be defective, we would ask that your piece of equipment be repaired by an authorized **Ross Video Limited** factory representative. Any attempt to repair this product by anyone other than an authorized **Ross Video Limited** factory representative, will void your warranty.

If this is a manual for a **Ross Gear** product of our **Digital Terminal Equipment** product line, a power supply, or piece of equipment which carries surface mount devices, you will find it provides all pertinent information for the safe installation and operation of your Ross Gear product.

If this is a manual for a **Ross Gear** product from our **Analog Terminal Equipment** product line, you will find it provides all pertinent information for the safe installation and operation of your **Ross Gear** product. Included in this manual if this product does not carry any surface mount devices, you will also find schematics, bills of materials and layout drawings. These are provided for your convenience, should you find it necessary to perform discretionary field repair or modifications to your **Ross Gear** product.

Ross Video Limited reserves the right to assess any modifications or repairs made by you and decide whether they fall within warranty limitations, should you decide to return your **Ross Gear** product for repair.

In no event shall **Ross Video Limited** be liable for direct, indirect, special, incidental, or consequential damages (including loss of profits) incurred by the use of this product. Implied warranties are expressly limited to the duration of this warranty.

In Case of Problems:

Should any problem arise with your **Ross Gear Terminal Equipment Product**, please contact our **Customer Service Department** at **613-652-4886**, 24 hours a day, 7 days a week.

A Return Material Authorization number (RMA) will be issued to you, as well as specific shipping instructions, should you wish our factory to repair your **Ross Gear** product. A temporary replacement, if required, will be made available for a nominal charge. Any shipping costs incurred, will be the responsibility of you, the customer. All products shipped to you from **Ross Video Limited**, will be shipped collect.

Ross Gear Terminal Equipment product advice is available without charge for the life of this equipment, not just the warranty period.