

Ports and Connectors

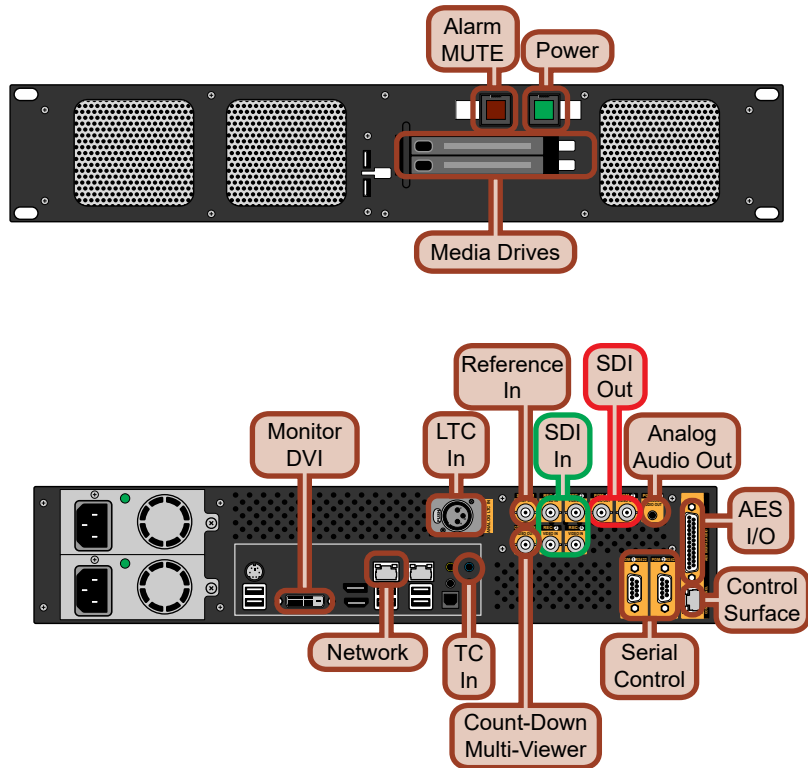

Power and Control Cabling

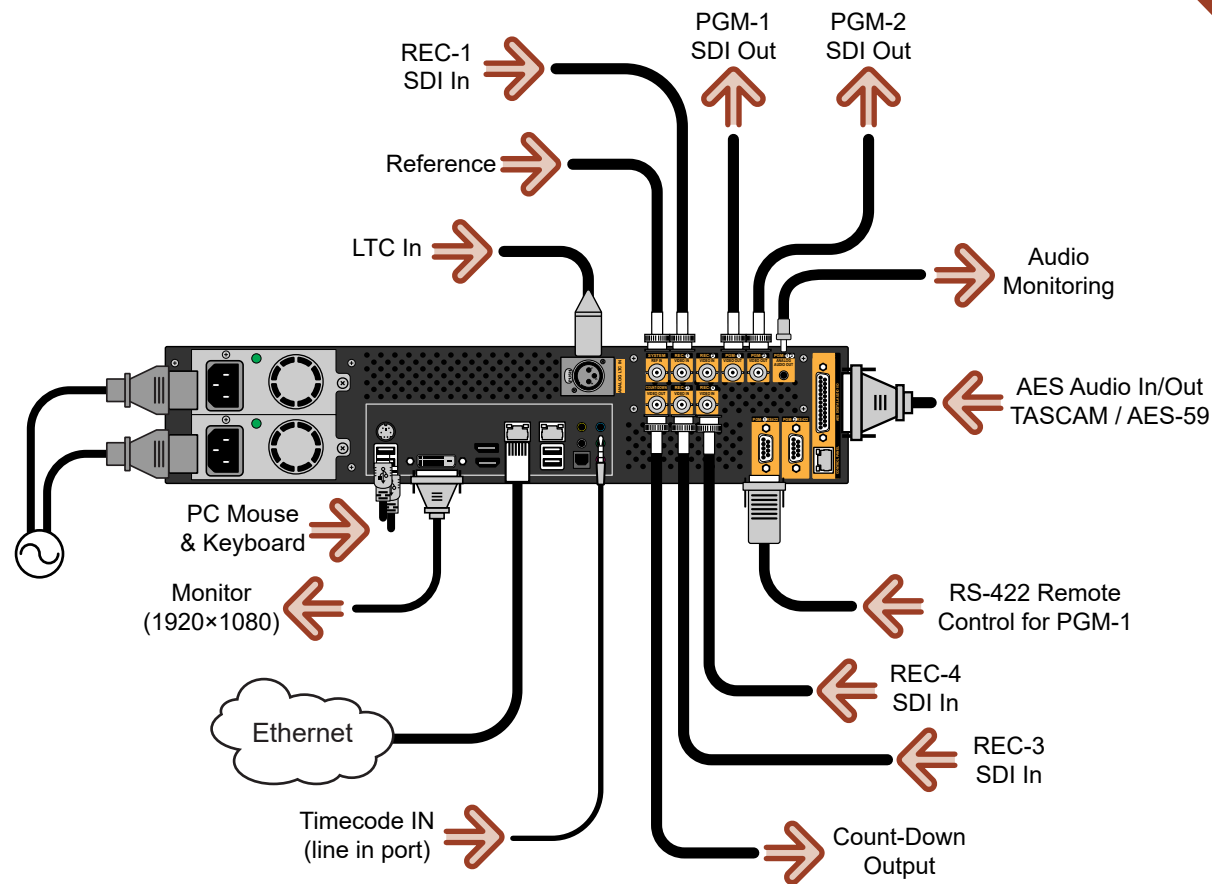

Note: It is recommended that you always connect the AC Power Adapter to the device before connecting to Mains Power.

Control Surface Connection

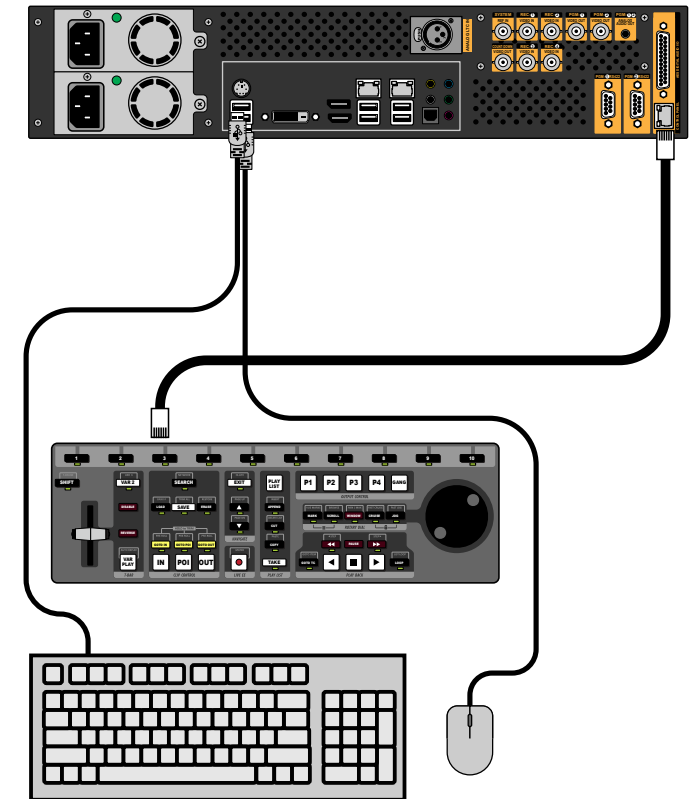

Notes:

- Only REC 1-4 can record.
- If you are recording from, or playing into, an external device you must have all devices connected to the same reference signal to ensure proper timing.
- The TC In (LINE IN) audio port is used for TC Chase.

RS422 (DB9)

Pin	Signal
1	Gnd
2	Tx-
3	Rx+
4	Rx Gnd
5	n/c
6	Tx Gnd
7	Tx+
8	Rx-
9	n/c

Specifications

SDI Video Formats	
525i (480i)	59.94Hz
625i (576i)	50Hz
720p	60Hz
720p	59.94Hz
720p	50Hz
1080i	59.94Hz
1080i	50Hz

Default Passwords	
Windows	Abekas
Administrator	multiflex

Input Voltages	
	100 to 240V~
	3 to 1.5A
	60 to 50Hz

Operating Environment	
Temperature:	20 - 35°C (68 - 95°F)
Humidity:	20 - 80%

Video/Audio Input Specifications	
Video Inputs, HD-SDI	SMPTE 292M 10-bit at 1.5Gb/s
Video Inputs, SD-SDI	SMPTE 259M 10-bit at 270Mb/s
Embedded Audio, HD-SDI	8 Tracks, 48kHz at 24-bit
Embedded Audio, SD-SDI	4 Tracks, 48kHz at 20-bit
AES Discrete Audio	8 Tracks AES59-2012/TASCAM Digital
Reference Input	Tri-Level HD or Composite Analog SD; Terminating
Native Codec	DVCpro @ 50Mb/s or 100Mb/s

Video/Audio Output Specifications	
Video Outputs, HD-SDI	SMPTE 292M 10-bit at 1.5Gb/s
Video Outputs, SD-SDI	SMPTE 259M 10-bit at 270Mb/s
Embedded Audio, HD-SDI	8 Tracks, 48kHz at 24-bit
Embedded Audio, SD-SDI	4 Tracks, 48kHz at 20-bit
AES Audio	8 Tracks AES59-2012/TASCAM Digital
Analog Audio Monitoring	3.5mm headphone connector, unbalanced, line-level at -10dBv, 2 Tracks (1 stereo pair), user selectable to monitor any out
Native Codec	DVCPro @ 50Mb/s or 100Mb/s

