



Panasonic Camera Control System Installation Guide

For DashBoard software version 9.9 (or higher)

Thank You for Choosing Ross

You've made a great choice. We expect you will be very happy with your purchase of Ross Technology.

Our mission is to:

1. Provide a Superior Customer Experience
 - offer the best product quality and support
2. Make Cool Practical Technology
 - develop great products that customers love

Ross has become well known for the Ross Video Code of Ethics. It guides our interactions and empowers our employees. I hope you enjoy reading it below.

If anything at all with your Ross experience does not live up to your expectations be sure to reach out to us at solutions@rossvideo.com.



David Ross
CEO, Ross Video
dross@rossvideo.com

Ross Video Code of Ethics

Any company is the sum total of the people that make things happen. At Ross, our employees are a special group. Our employees truly care about doing a great job and delivering a high quality customer experience every day. This code of ethics hangs on the wall of all Ross Video locations to guide our behavior:

1. We will always act in our customers' best interest.
2. We will do our best to understand our customers' requirements.
3. We will not ship crap.
4. We will be great to work with.
5. We will do something extra for our customers, as an apology, when something big goes wrong and it's our fault.
6. We will keep our promises.
7. We will treat the competition with respect.
8. We will cooperate with and help other friendly companies.
9. We will go above and beyond in times of crisis. *If there's no one to authorize the required action in times of company or customer crisis - do what you know in your heart is right. (You may rent helicopters if necessary.)*

Panasonic Camera Control System Installation Guide

- Ross Part Number: **8351DR-008-9.9**.
- Publication Date: April 12, 2024. Printed in Canada.
- For DashBoard Software Version: 9.9 (or higher)

Copyright

©2024 Ross Video Limited, Ross®, and any related marks are trademarks or registered trademarks of Ross Video Limited. All other trademarks are the property of their respective companies. PATENTS ISSUED and PENDING. All rights reserved. No part of this publication may be reproduced, stored in a retrieval system, or transmitted in any form or by any means, mechanical, photocopying, recording or otherwise, without the prior written permission of Ross Video. While every precaution has been taken in the preparation of this document, Ross Video assumes no responsibility for errors or omissions. Neither is any liability assumed for damages resulting from the use of the information contained herein.

Patents

Ross Video products are protected by patent numbers US 7,034,886; US 7,508,455; US 7,602,446; US 7,802,802 B2; US 7,834,886; US 7,914,332; US 8,307,284; US 8,407,374 B2; US 8,499,019 B2; US 8,519,949 B2; US 8,743,292 B2; GB 2,419,119 B; GB 2,447,380 B. Other patents pending.

Company Address



Ross Video Limited

8 John Street
Iroquois, Ontario
Canada, K0E 1K0

Ross Video Incorporated

P.O. Box 880
Ogdensburg, New York
USA 13669-0880

General Business Office: (+1) 613 • 652 • 4886

Fax: (+1) 613 • 652 • 4425

Technical Support: (+1) 613 • 652 • 4886

After Hours Emergency: (+1) 613 • 349 • 0006

E-mail (Technical Support): techsupport@rossvideo.com

E-mail (General Information): solutions@rossvideo.com

Website: <http://www.rossvideo.com>

Contents

Welcome	1
Documentation Conventions	1-1
Contacting Technical Support	1-2
System Overview and Planning	2
System Overview	2-1
Planning the Workstation Components	2-2
Planning the Studio and Network Components	2-3
Hardware and Software Checklist	2-6
Installing the System	3
Establish a Network	3-1
Install Camera Control Computers	3-1
Install Camera Paint Boxes	3-2
Install the Proxy Server	3-2
Install and Configure Panasonic Cameras	3-2
Install Serial to Ethernet Converters (Control Units)	3-3
Configure Serial to Ethernet Converters (Control Units)	3-4
Install DashBoard Software on All Computers	3-5
Configure the First Computer	3-5
Configure Additional Computers	3-9
Configure the Camera Paint Box Connection	3-10
Install the Camera Video Monitor(s) and Routing/Switching Equipment	3-11

Welcome

This is the Installation Guide for Ross Video’s Panasonic Camera Control System.

The Panasonic Camera Control System enables you to adjust lens iris, camera paint (shading), and all camera menu settings for supported Panasonic cameras.

The Panasonic Camera Control System can be set up as a standalone camera control system, or be integrated with a Ross Robotics robotic camera system.

This Installation Guide describes how to install and configure the Panasonic Camera Control System as a standalone camera control system.

Tip: If you set up a standalone system, and later purchase Ross Robotics, you can reconfigure the Panasonic Camera Control System to integrate it with your Robotics system.

For information about how to use the Panasonic Camera Control System, see the *Panasonic Camera Control System User Guide (8351DR-009-xx)*.

Documentation Conventions

Text Format Conventions

Special text formats are used in this Installation Guide to identify parts of the user interface, text that a user must enter, or a sequence of menus and submenus that must be followed to reach a particular command.

Text Format	Meaning
Bold text	Bold text is used to identify a user interface element such as a dialog box, menu item, or button. For example: In the Display Name box, type a name for the node.
Courier text	Courier text is used to identify text that a user must type. For example: In the address bar, type localhost and press Enter .
<i>Italic text</i>	Italic text is used to identify the titles of referenced guides, manuals, or documents. For example: For more information, see the <i>Panasonic Camera Control System User Guide (8351DR-009-xx)</i> .
>	Menu arrows are used in procedures to identify a sequence of menu items that you must follow. For example, if a step reads “ File > New ,” you would tap the File menu and then tap New .

User Interface Conventions

You can interact with the Panasonic Camera Control System using a touch screen and/or a keyboard and mouse. The instructions in this Installation Guide describe how to interact with the Camera Control Panel using a touch screen. The following table provides equivalent actions for using a keyboard and mouse.

Instruction	Touch Screen	Keyboard and Mouse
tap	Tap the object briefly.	Click the object. Click refers to pressing the left mouse button briefly. Right-click refers to pressing the right mouse button briefly.
touch and hold	Touch the object and hold your finger on it until a circle appears, and then release it.	Right-click and hold your finger on the mouse button until the expected action occurs.
drag	Touch the object, hold your finger on it, and drag your finger on the screen to move the object.	Click and drag the object.

Contacting Technical Support

At Ross Video, we take pride in the quality of our products, but if problems occur, help is as close as the nearest telephone.

Our 24-hour Hot Line service ensures you have access to technical expertise around the clock. After-sales service and technical support is provided directly by Ross Video personnel. During business hours (Eastern time), technical support personnel are available by telephone any time. After hours and on weekends, a direct emergency technical support phone line is available. If the technical support person who is on call does not answer this line immediately, a voice message can be left and the call will be returned shortly. This team of highly trained staff is available to react to any problem and to do whatever is necessary to ensure customer satisfaction.

- **Technical Support:** (+1) 613-652-4886
- **After Hours Emergency:** (+1) 613-349-0006
- **E-mail:** techsupport@rossvideo.com
- **Website:** <http://www.rossvideo.com>

System Overview and Planning

This section provides information about the Panasonic Camera Control System that can help you plan your installation. It contains the following topics:

- “**System Overview**” on page 2–1
- “**Planning the Workstation Components**” on page 2–2
- “**Planning the Studio and Network Components**” on page 2–3
- “**Hardware and Software Checklist**” on page 2–6

System Overview

The Panasonic Camera Control System enables you to adjust lens iris, camera paint (shading), and all camera menu settings for supported Panasonic cameras. It can be set up as a standalone camera control system, or integrated with a Ross Robotics robotic camera system.

This Installation Guide describes how to install and configure the Panasonic Camera Control System as a standalone camera control system.

This section lists the components of the system, and includes a system architecture diagram.

Workstation Components

The Panasonic Camera Control System includes one or more camera control workstations. Each workstation can control all cameras. Each workstation consists of the following:

- A Camera Control Computer, monitor, keyboard, and mouse.
- A Camera Video Monitor. This monitor (not included) displays video from the camera being controlled, so you can see on-screen menus and monitor the effect of adjustments as you make them.
- A Camera Paint Box (Optional). The Camera Paint Box features physical knobs for adjusting iris and paint controls (gains and pedestals). These settings can also be controlled through the Camera Control Panel.

For more detailed information about the workstation components, see “**Planning the Workstation Components**” on page 2–2.

Studio and Network Components

Studio and network components include the following:

- Network Switch. The system can use a dedicated network switch, or use an existing LAN.
- Panasonic cameras. The system can control iris and paint functions on select Panasonic cameras.
- Serial to Ethernet Converter. These units convert RS-422 signal from the camera to Ethernet communication.
- Proxy server computer. In systems with multiple camera control workstations, the proxy server communicates with the cameras. All camera control requests from camera control computers are handled by the proxy server.

For more detailed information about the studio and network components, see “**Planning the Studio and Network Components**” on page 2–3.

System Architecture Diagram

Figure 2.1 shows the architecture of a Panasonic Camera Control System that includes six cameras in two studios. There are two camera control workstations. Each workstation includes an optional Camera Paint Box. Each studio has a serial-to-Ethernet converter (Control unit) that can host up to four cameras. The Control unit connects to the Ethernet network, and eliminates the need to run individual serial cables from each camera to the proxy server in the rack room.

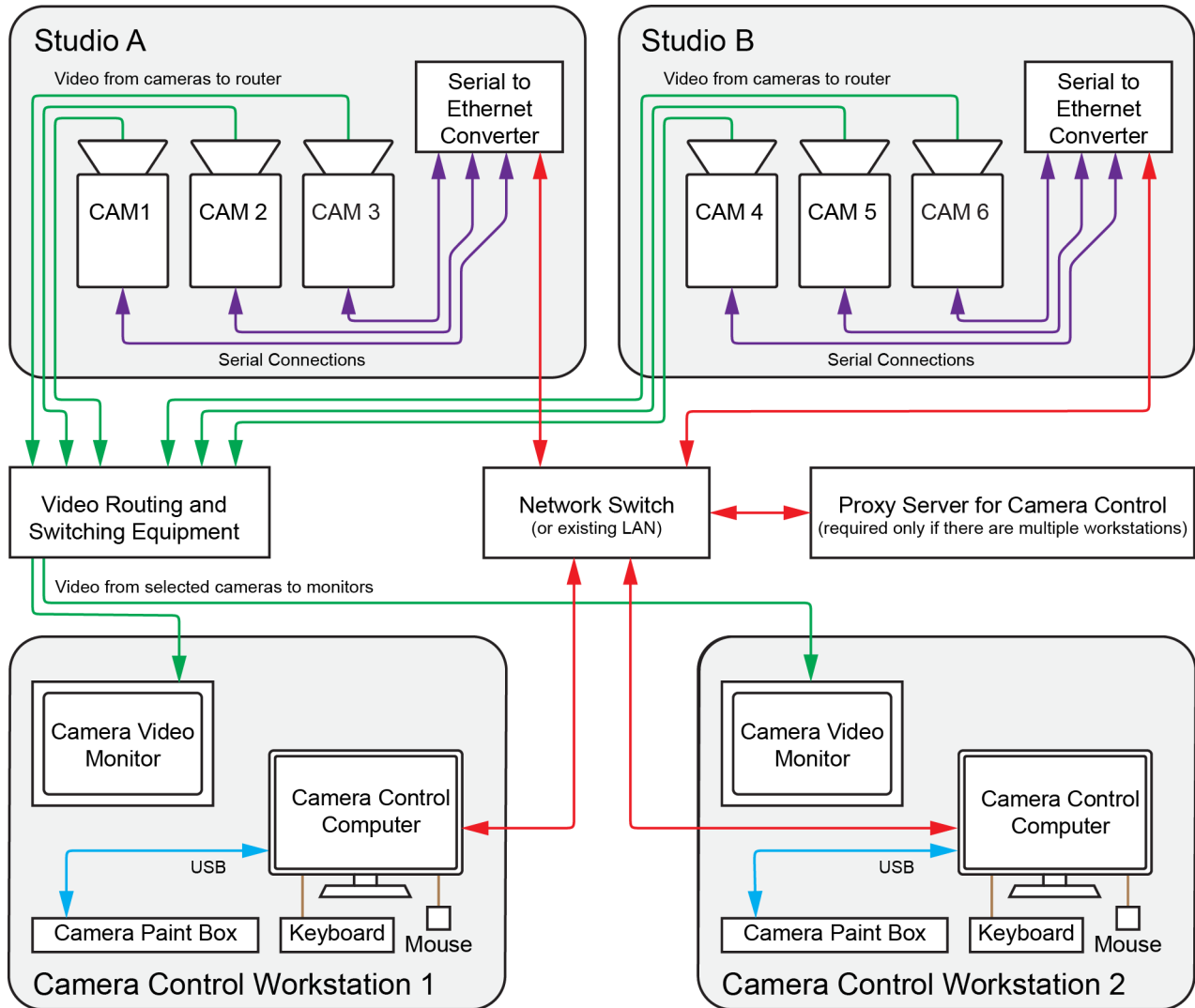

Figure 2.1 - Architecture of a Standalone Panasonic Camera Control System (an example)

Planning the Workstation Components

This section describes the components of a camera control workstation, to help you plan your installation.

The main topics in this section are as follows:

- “**Camera Control Computer and Accessories**” on page 2–3
- “**Camera Video Monitor**” on page 2–3
- “**Camera Paint Box (optional)**” on page 2–3

Camera Control Computer and Accessories

The Camera Control Computer runs DashBoard, which is a versatile control and monitoring interface for many Ross Video and openGear Partner devices. Through DashBoard you can access the Camera Control Panel, which is the camera control interface featuring camera iris and paint (shading) controls. The Camera Control Panel also provides access to on-screen camera configuration menus.

You need one Camera Control Computer running DashBoard at each camera control workstation. DashBoard is free, but the Panasonic Camera Control System is a licensed application. You require one license for each camera control workstation.

You can purchase your Camera Control Computer(s) from Ross Video. Alternatively, you can use any computer that meets the Windows system requirements for installing DashBoard. To view the DashBoard system requirements, download the DashBoard User Guide at <http://www.rossvideo.com/control-systems/dashboard/index.html>.

If your system includes multiple camera control workstations, the camera control computers are set up in a primary-secondary topology. On each camera control computer, DashBoard is configured to be a secondary instance. On an additional proxy server computer, DashBoard is configured to be the primary instance.

Camera Video Monitor

The camera video monitor can display video from the camera being controlled, so you can see on-screen menus and monitor the effect of adjustments as you make them. The camera video monitor is usually a carefully calibrated reference monitor. Sometimes two monitors are used, to compare video output of two cameras side-by-side. Video routing equipment is required to direct the desired video feed to the monitor(s).

Note: Camera video monitors and routing equipment operate independent of the Camera Control System. The Camera Control Panel and Camera Paint Box do not select video to be displayed on camera video monitors.

When adjusting paint controls, technicians often use a waveform/vectorscope to fine-tune the properties of the camera output. The Camera Control Panel enables you to access the camera's color bars output for calibration purposes.

Camera video monitors, video routing equipment, and waveforms/vectorscopes are not included as part of the Panasonic Camera Control System.

Camera Paint Box (optional)

The Camera Paint Box is an optional accessory that features physical knobs for adjusting iris and paint controls (gains and pedestals). These settings can also be controlled through the Camera Control Panel.

Each camera control workstation may or may not include a Camera Paint Box.

The Camera Paint Box is connected to the camera control computer by a USB cable. The Camera Paint Box is designed to occupy 1RU in a standard 19" component rack.

Planning the Studio and Network Components

This section describes the studio and network components of a camera control workstation, to help you plan your installation.

The main topics in this section are as follows:

- “**Cameras**” on page 2–4
- “**Serial to Ethernet Converter(s)**” on page 2–4
- “**Proxy Server Computer**” on page 2–5
- “**Network Configuration**” on page 2–5

Cameras

The Panasonic Camera Control System works with Panasonic AK-HC1500 video cameras, and may work with other Panasonic cameras that communicate over RS-422 serial protocol. For information about which Panasonic cameras are supported, contact Ross Video.

Serial to Ethernet Converter(s)

Supported Panasonic cameras communicate over RS-422 protocol. Serial to Ethernet converters enable the camera to communicate with other components of the Camera Control System.

The Camera Control System uses the Control DeviceMaster RTS 4-Port DB9 four-port device server as a serial to Ethernet converter. The Control unit is available from Ross Video.

The number of Control units required depends on the number of cameras to be controlled, and their locations. Each Control unit can host up to four cameras. Control units are typically located close to the cameras, to reduce cable runs.

For example, if there are a total of six cameras split evenly between two studios, you would typically install one Control unit in each studio, as shown in the “**System Architecture Diagram**” on page 2–2.

Serial Cables Between Cameras and Control Units

Each camera connects to a Control unit through a serial cable assembly. Because the required length of the cable assembly varies for each camera installation, each cable assembly is custom-made.

For each camera, you can make your own cable assembly end-to-end, or buy a set of two adapter cables from Ross Video and then make a custom-length cable to span between them (**Figure 2.2**).

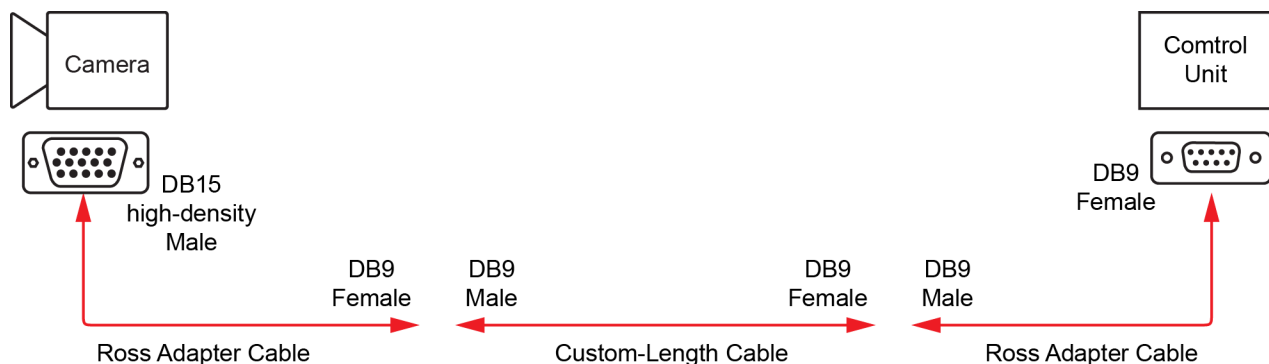

Figure 2.2 - Serial Cable Assembly Made With Ross Adapter Cables

Note: If you use a set of two Ross Video adapter cables, you must use both cable adapters. You cannot use only the cable adapter that attaches to the camera, because the cable pinouts will not be correct.

Tip: For the custom-length cable that spans between the two adapter cables, only pins 1 to 5 are used.

To manufacture an end-to-end cable assembly without Ross Video adapter cables, the pinout information is as follows:

Table 2.1 - Pinouts for Custom End-to-End Serial Cable Assembly

Camera End Female DB9	Control End Male DB15 (high density)
Pin 4	Pin 2
Pin 5	Pin 3
Pin 10	Pin 7

Table 2.1 - Pinouts for Custom End-to-End Serial Cable Assembly

Camera End Female DB9	Control End Male DB15 (high density)
Pin 9	Pin 8
Pins 11, 12,13,14,15	SHELL

IMPORTANT: When using robotic camera systems, make sure all cable assemblies are long enough to accommodate the full range of camera motion.

Proxy Server Computer

If your system includes multiple camera control workstations, the camera control computers are set up in a client/server topology. On the proxy server, DashBoard is configured to be the 'proxy server' instance. On each camera control computer, DashBoard is configured to be a client of the proxy server instance.

The proxy server communicates with the cameras. All camera control requests from camera control computers are handled by the proxy server.

Because the proxy server must remain on at all times, we recommend you use a server-grade computer installed in a rack room. Alternatively, you can designate one of the camera control computers to act as the proxy server.

You can purchase a server from Ross Video. Alternatively, you can use any computer that meets the Windows system requirements for installing DashBoard. To view the DashBoard system requirements, download the DashBoard User Guide at <http://www.rossvideo.com/control-systems/dashboard/index.html>.

Network Configuration

Components of the Panasonic Camera Control System communicate over an Ethernet network. You can use a dedicated network switch, or an existing network.

The following components require Ethernet network connections:

- Each Camera Control Computer
- Each Control unit
- The proxy server (only required for systems that have multiple camera control workstations)

Note: Ethernet cables between components are not included.

Hardware and Software Checklist

The tables in this section list everything you need to purchase for your system. You can use them as checklists when determining what you need.

Table 2.2 - Camera Control Workstation Equipment and Software

Quantity	Item	Source	Notes / Requirements
	Camera Control Computer Must include monitor, keyboard, and mouse.		One computer per workstation. Ross Video sells an all-in-one computer for this purpose. Computers must meet Windows system requirements for DashBoard installation. Computers require power supply outlets.
	Panasonic camera control license	Ross Video	One license per camera control workstation.
	Camera Paint Box	Ross Video	Maximum one per workstation. Optional accessory. The Camera Paint Box requires a power supply outlet.
	Camera video monitor and waveform/vectorscope	Other	Minimum one per workstation. Can have multiple monitors for side-by-side comparison of camera outputs. May also require waveform/vectorscope for fine-tuning camera output. Monitors and waveform/vectorscopes require power supply outlets.
	Routing and switching equipment for camera video monitor(s) Must include video cabling between cameras and router, and between router and monitor(s).		Independent of Camera Control System. Typically, an existing video router is used. Ross Video can provide video routing solutions. Routing equipment requires power supply outlets.

Table 2.3 - Studio and Network Equipment

Quantity	Item	Source (Ross or Other)	Notes
	Panasonic camera	Other	Contact Ross Video for information about which Panasonic cameras are supported. Each camera requires a power supply outlet.
	Serial to Ethernet converter Control DeviceMaster RTS 4-Port DB9 four-port device server	Ross Video	Each Control unit can host up to four cameras. Each Control unit requires a power supply outlet.

Source			
Quantity	Item	(Ross or Other)	Notes
	Serial cable assembly		<p>One per camera.</p> <p>Each serial cable assembly is custom-made, and connects a camera to a Control unit.</p> <p>For more information, see “Serial Cables Between Cameras and Control Units” on page 2–4.</p>
	Proxy server for camera control		<p>Required if your system has multiple camera control workstations.</p> <p>Ross Video sells servers for this purpose</p> <p>Server must meet Windows system requirements for DashBoard installation.</p> <p>Server requires a power supply outlet.</p>
	Panasonic camera control license for proxy server computer	Ross Video	<p>License fees are based on the number of camera control workstations in your system.</p> <p>If your system has a proxy server running on a separate computer (as opposed to running on a camera control computer), the license for the proxy server computer is provided free of charge.</p>
	Network Switch	Other	Can use dedicated network switch, or an existing LAN.
	Ethernet network cables	Other	<p>The following require network connections:</p> <ul style="list-style-type: none"> • Each Camera Control Computer • Each Control Unit • Proxy server (if equipped)

Installing the System

This section describes how to install and configure a standalone Panasonic Camera Control System.

Before you install the system, you need to plan the installation. For more information, see “**System Overview and Planning**” on page 2–1.

9.9 (or higher) Perform the installation procedures in the following order:

1. “**Establish a Network**” on page 3–1
2. “**Install Camera Control Computers**” on page 3–1
3. “**Install Camera Paint Boxes**” on page 3–2
4. “**Install the Proxy Server**” on page 3–2
5. “**Install and Configure Panasonic Cameras**” on page 3–2
6. “**Install Serial to Ethernet Converters (Control Units)**” on page 3–3
7. “**Configure Serial to Ethernet Converters (Control Units)**” on page 3–4
8. “**Install DashBoard Software on All Computers**” on page 3–5
9. “**Configure the First Computer**” on page 3–5
10. “**Configure Additional Computers**” on page 3–9
11. “**Configure the Camera Paint Box Connection**” on page 3–10
12. “**Install the Camera Video Monitor(s) and Routing/Switching Equipment**” on page 3–11

Establish a Network

The Panasonic Camera Control System can use a dedicated network switch, or use an existing LAN.

To set up a dedicated network switch:

1. Install the network switch in an appropriate location.
2. Connect the power supply for the switch.
3. Turn on the switch.

Install Camera Control Computers

Each workstation includes one camera control computer. This section describes how to install a camera control computer provided by Ross Video. If your computer is not provided by Ross Video, the steps may vary somewhat.

To install a Camera Control Computer and Peripherals:

1. Position the camera control computer in the camera control workstation location.
Ensure that the touch-screen monitor is within easy reach of the operator. Ensure that the optical drive, accessory ports, and buttons on the right and left edges of the computer are accessible.
2. Position the keyboard and mouse within easy reach of the operator, and then plug them into the connection panel on the back of the computer.
3. Plug one end of an Ethernet cable into the connection panel on the back of the computer. Connect the other end to the network.
4. Connect the power cable to the computer, and to a suitable power outlet.
5. Configure the networking parameters (IP address, subnet mask, and gateway).

Install Camera Paint Boxes

The Camera Paint Box is an optional accessory. Each work station may or may not include a Camera Paint Box.

To install a Camera Paint Box:

1. Position the Camera Paint Box in the camera control workstation location.
Ensure that the Camera Paint Box is within easy reach of the operator.
The Camera Paint Box can sit on a flat surface, or occupy 1RU in a standard 19” component rack.
2. Plug one end of the provided USB cable into the Camera Paint Box. Plug the other end into a USB connector on the back of the camera control computer.
3. Plug the power cable into the Camera Paint Box, and into a suitable power outlet.
On the front of the Camera Paint Box, a green LED indicates that the unit is powered.

Install the Proxy Server

This section applies only if your system has multiple camera control workstations.

The proxy server communicates with the cameras on behalf of the camera control computers. It must always be running, and must be on the same network as the other components of the system.

This section describe how to set up a proxy server computer provided by Ross Video. If your computer is not provided by Ross Video, the steps may vary somewhat.

The operator does not need access to the proxy server. The server can be installed in a rack room. It does not need a dedicated keyboard and mouse. You can use a KVM, or use Windows Remote Desktop to interact with the server.

To install the Proxy Server:

1. Position and install the server in a standard 19” component rack.
2. Connect the power cable to the computer, and to a suitable power outlet.
3. Plug one end of an Ethernet cable into the server. Connect the other end to the network.
4. Turn on the server.
5. Configure the networking parameters (IP address, subnet mask, and gateway).

Install and Configure Panasonic Cameras

This section describes how to install Panasonic cameras, and how to set their communication protocol to RS-422.

To install and configure a camera:

1. Position and mount the camera.
2. On the camera, find the **IRIS** switch and set it to the **automatic (A)** position.
3. Plug the camera power supply unit into the camera and to a suitable power outlet.
4. Plug the video output from the camera into a video monitor. Turn on the video monitor so you see the camera output.
5. On the back of the camera, press and hold the **MENU** button until the **USER MENU** appears on the monitor.
6. Using the **DOWN** and **UP** buttons, navigate to the **SETTING** option, and then press the **ENTER** button.
The **SETTING** menu appears.
7. On the **SETTING** menu, navigate to the **PROTOCOL** option and then press the **ENTER** button.
The **PROTOCOL** menu appears.

8. On the **PROTOCOL** menu, navigate to the **PROTOCOL** option and then press the **ENTER** button.
The **PROTOCOL** value flashes.
9. Using the **DOWN** and **UP** buttons, set the **PROTOCOL** value to **3**, and then press the **ENTER** button.
The **PROTOCOL** value stops flashing.
10. Disconnect camera power to turn off the camera.
The communication protocol is set and will be applied when the camera is turned on again.
11. Disconnect the video output cable from the camera.

Install Serial to Ethernet Converters (Control Units)

Supported Panasonic cameras communicate over RS-422 protocol. Serial to Ethernet converters enable the camera to communicate with other components of the Camera Control System.

The Camera Control System uses the Control DeviceMaster RTS 4-Port DB9 four-port device server as a serial to Ethernet converter. The Control unit is available from Ross Video.

Each Control unit can host up to four cameras.

To install a Control unit:

1. Position and mount each Control unit such that:
 - Serial control cables can be run between the Control unit and the cameras it hosts.
 - An Ethernet cable can be run from the Control unit to the network.
 - A suitable power outlet is available for the Control unit.
 - The Control unit is close to the cameras it hosts, to reduce cable runs.
2. Connect a serial cable assembly from each camera to a Control unit.

For more information about making custom serial cable assemblies, see “**Serial Cables Between Cameras and Control Units**” on page 2–4.

Note which camera is plugged into which Control port.

Tip: Ports are labeled **RX1/TX1** through **RX4/TX4**.

3. Connect an Ethernet cable between the network and the left Ethernet connector (labeled **UP**) on the Control unit.
4. Plug the power supply cable into the Control unit, and into a suitable power outlet.

Configure Serial to Ethernet Converters (Control Units)

This section describes how to configure the serial-to-Ethernet converter (Control unit) to communicate with cameras and other devices in the system.

Note: To perform the steps in this section, you need to have good working knowledge of basic computer networking procedures.

The steps in this section require a Windows laptop computer and a short Ethernet cable.

To configure a Control unit:

1. On the Control unit, disconnect the network Ethernet cable from the left Ethernet connector (labeled **UP**).
2. Connect the short Ethernet cable between the laptop computer and the left Ethernet connector (labeled **UP**) on the Control unit.
3. Configure the IP address of the Windows laptop computer so it can communicate with the Control unit.

The default Control network settings are as follows:

- IP Address: 192.168.250.250
- Subnet mask: 255.255.0.0
- Gateway address: 192.168.250.1

4. Connect power to the Control unit.

The unit initializes.

5. On the Windows laptop computer, in a Web browser, navigate to the IP address of the Control unit (<http://192.168.250.250>).

The Control configuration page appears, showing four columns of configuration settings; one for each port.

6. For each port to which a camera is connected, do the following

- a. Click the numbered **Port** link at the top of the column.

The **Edit Port Configuration** page appears.

- b. In the **Serial Configuration** area, set **Mode** to **RS-422**.
- c. Set the **Baud** rate to **9600**.
- d. Set **Parity** to **None**, set **Data Bits** to **8**, and set **Stop Bits** to **1**.
- e. Set **Flow** to **None**.
- f. Set **DTR** and **RTS** both to **OFF**.
- g. In the **TCP Connection Configuration** area, select **Enable and Listen**.
- h. Set the **Listen Port** to a unique port number.

This value is arbitrary. Note which port number you assign to which camera.

- i. Set the **Connect To IP** address to **0.0.0.0**.
- j. Set the **To Port** value to **0**.
- k. Set the **From Port** value to **0**.
- l. For **Connect On** settings, select **Always** only.
- m. For **Disconnect On** settings, ensure no options are selected.
- n. Tap **Save**.

The **Configuration Updated** message appears.

- o. Tap **OK**.

7. In the **Server Configuration** area, tap **Configure Network**.
8. Set **IP Configuration** to **Use static configuration below**:
9. Set the **IP Address**, **Netmask**, and **Gateway** for the **Control** unit.
The IP address will be used to connect to cameras from DashBoard.
10. Tap **Save**.
The **Configuration Updated** message appears, along with notification that changes to the IP address will not take effect until the DeviceMaster unit is rebooted.
11. Tap **OK**.
12. Tap **Reboot**.
A confirmation message asks whether you want to reboot.
13. Tap **Yes: Reboot**.
The Control unit reboots.
14. For each camera connected to the Control unit, make a note of its IP address and port. The IP address is the IP address of the Control unit. The port is the port you assigned for the camera. This information is required to add the cameras to DashBoard later.
15. Disconnect the laptop from the Control unit, and reconnect the network Ethernet cable to the left Ethernet connector (labeled **UP**) on the Control unit.

Install DashBoard Software on All Computers

Install the latest version of DashBoard (v8.1.1 or higher) on each Camera Control Computer and on the proxy server (if present).

DashBoard and the DashBoard User Guide are available as free downloads from Ross Video. The DashBoard User Guide contains instructions for installing DashBoard. Both are available at the following location:

<http://www.rossvideo.com/control-systems/dashboard/index.html>.

Configure the First Computer

The steps for configuring the first computer in the Camera Control System are different than the steps for subsequent computers:

- If your system includes only one camera control workstation, the camera control computer is the first (and only) computer.
- If your system includes multiple camera control workstations, the proxy server is the first computer.

DashBoard is free, but use of the Camera Control System requires one license per computer. During the configuration process, DashBoard provides a Request Code and requires a License Key in response. The License Key can be obtained only by relaying the Request Code to Ross Video Technical Support. The License Key cannot be obtained in advance because it is a response to the unique Request Code generated by DashBoard.

Note: To perform the steps in this section, you need to have good working knowledge of basic computer networking procedures.

To configure the computer, you configure network settings, then add all cameras in the system, one at a time. If the computer is a proxy server, you also share the cameras so that camera control computers can access them.

To configure network settings:

1. Configure the network settings on the computer so it can communicate with the Control unit(s).
If this computer is the proxy server, note its IP address.

To add a camera:

1. On the first computer, open DashBoard.
2. From the **File** menu, tap **New**, and then tap **Other**.
The **New** dialog box appears.
3. Expand the **Camera Control** node, tap **Panasonic Camera**, and then tap **Next**.
The **New Ross Video Panasonic Camera Connection** dialog appears.
4. In the **IP Address** box, type the IP address of the Control unit that hosts the camera you want to add.
5. In the **Slot** box, specify a slot number for the camera. Valid slot numbers start at **1**.

Tip: In the Camera Control Panel, the order of camera selection buttons is determined by slot number, starting with the lowest number at the top.

In the **Port** box, type the port number for the camera you want to add.

Note: When adding a **Panasonic AW-UE150** PTZ camera, for DashBoard v9.8 or higher, a **Port** box appears. The default port is 80. Refer to ([Figure 1](#)).

The screenshot shows a dialog box titled "New PTZ Cameras Connection". Below the title is a sub-header "PTZ Cameras Connection" and a red error message: "No host name or IP address." The dialog contains several input fields: "IP Address:" (empty), "Display Name:" (PTZ Cameras), "Slot:" (1), "Model:" (Panasonic AW-UE150), and "Port:" (80).

Figure 1 - Connecting a Panasonic AW-UE150 PTZ camera in DashBoard

6. Tap the **Finish** button.
7. Integrating a third-party camera with DashBoard necessitates license activation. DashBoard supports two licensing options: **Software-Based Licensing** and **Ross Key Based Licensing**.

Software-based licensing involves connection of DashBoard to the Ross activation server either directly or via a Ross Product Manager licensing server on prem. To use software-based licensing, you will need a product key provided by Ross.

Ross Key Based Licensing is a fixed license tied to your hardware. During the licensing process you will need to send a key code to Ross technical support who will return a license key for you to enter into DashBoard.

For more information, refer to the DashBoard User Guide **8351DR-004-XX**.

Note: Product key packs do not require a hardware request code but does require an RPM sever or access to the Activation server.

For activating DashBoard licensed features, refer to the following procedures:

To update DashBoard licensed features (Software Based Licensing method)

- a. From the main toolbar, select **Window > Preferences**. Refer to [Figure 2](#).

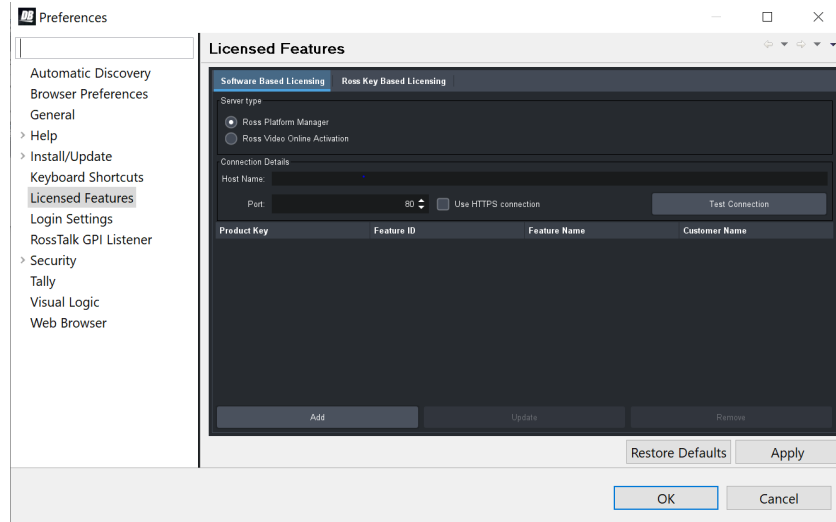

Figure 2 - DashBoard Licensed Features - Software Based Licensing tab

- b. The **Preferences** dialog box opens.
- c. From the **Preferences** dialog box, select **Licensed Features**.
- d. In the **Licensed Features** dialog box, ensure the **Software Based License** tab is selected.
- e. Select the **Server type** that you are using to provide licensing.
- f. If you are using the Ross Platform Manager server type, enter the **Host Name** and **Port** of the server and whether to **Use HTTPS connection**.
Note: Select **Apply** to save your server settings.
Note: Use the **Test Connection** button to confirm a successful connection if necessary.
- g. Once connection to the server is established, select **Add** and enter the product key provided to you. If successful, the feature you added will appear in the **Licensed Features** table.
Note: Select **Apply** to confirm your changes.

To update DashBoard licensed features (Ross Keys Based Licensing method)

For obtaining and entering a Ross licensing key code, complete the following:

- a. From the main toolbar, select **Window > Preferences**. Refer to [Figure 3](#).

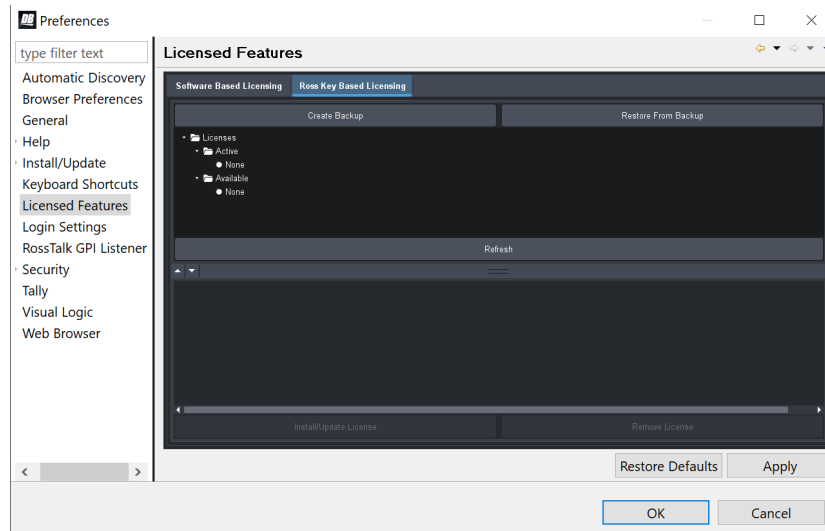

Figure 3 - DashBoard Licensed Features - Ross Key Based Licensing tab

- b. The **Preferences** dialog box opens.
- c. From the **Preferences** dialog box, select **Licensed Features**.
- d. In the **Licensed Features** dialog box, ensure the **Ross Key Based License** tab is selected.
- e. From either the **Active** or **Available** subfolder, select the feature you want to update.
- f. To obtain a Ross License Key by completing the following:
 - i. Click **Install/Update License**.
 - ii. The **Enter License Key** dialog box opens. Refer to [Figure 4](#).

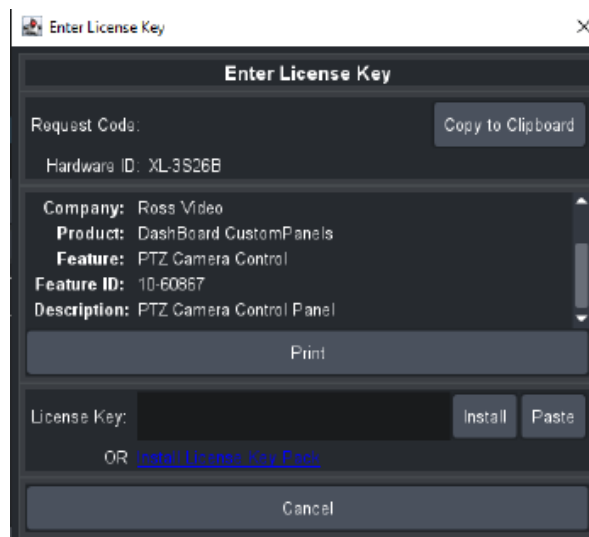

Figure 4 - DashBoard Licensed Features - Enter License Key

- iii. Select **Copy to Clipboard** to copy your request code.
- iv. Paste the request code into an e-mail to Ross Video (techsupport@rossvideo.com), requesting a corresponding license key. Be sure to include the original Ross Video sales order number.

CAUTION: Do not close the **Enter License Key** dialog box until you receive and apply an activation code from Ross Video. If you leave the **Enter License Key** dialog box, the activation code you receive will not work. It is valid only for the session during which it was generated.

- v. When you receive the license key via email, copy and paste it into the **License Key** box, and then tap **Install**.
 - vi. The selected feature updates and the most current data is displayed in the **License Details**.
8. If the camera is ceiling-mounted (inverted), we recommend you turn **On** the **Image Flip** and **Image Mirror** options (also known as **Ceiling Mount** for some cameras) before you create any presets. Changing these settings after presets exist renders the presets useless.
The **Image Flip** and **Image Mirror** options are available in the PTZ Camera Control plugin at **Config > Camera > Camera Options**.

Configure Additional Computers

This section applies only if your system has multiple camera control workstations.

DashBoard is free, but use of the Camera Control System requires one license per computer. During the configuration process, DashBoard provides a Request Code and requires a License Key in response. The license key can be obtained only by relaying the Request Code to Ross Video Technical Support. The License Key cannot be obtained in advance because it is a response to the unique Request Code generated by DashBoard.

Note: To perform the steps in this section, you need to have good working knowledge of basic computer networking procedures.

To configure additional computers:

1. Configure the network settings on the computer so it can communicate with the Control unit(s).
2. Open DashBoard.
3. From the **File** menu, tap **New**, and then tap **New TCP/IP DashBoard Connect or openGear Device**.
The **TCP/IP DashBoard Connect/openGear Device** dialog box appears.
4. In the **IP Address** box, type the IP address of the proxy server.
5. In the **Display Name** box, type a name for the camera node, as you want it to appear in the DashBoard component tree.
6. Select the **JSON** protocol.
7. In the **Port** box, type **5254**.
8. Tap **Finish**.
9. In the **DashBoard Component Tree**, expand the **Panasonic Cameras** node.
10. Expand the **Slot** node for the camera you just added.
11. Double-tap **Remote Control**.
12. If the **Camera Control Panel** appears, go to **Step 18 on page 3-10**.
13. In the **Enter License Key** interface, tap **Copy to Clipboard**.
The request code is copied to the clipboard.
14. Paste the request code into an e-mail to Ross Video (techsupport@rossvideo.com), requesting a corresponding license key. Be sure to include the original Ross Video sales order number.
IMPORTANT: Do not do anything with the computer until you receive a license key from Ross Video. If you leave the **Enter License Key** page, the license key you receive will not work. It is valid only for the session during which it was generated.
15. When you receive the license key, copy it and paste it into the **License Key** box, and then tap **Install**.

The **License Installed** message appears. Tap **OK**.

16. In DashBoard, close the **Panasonic Cameras - Slot *x* tab**.

17. In the **Component Tree**, double-tap **Remote Control**.

The **Camera Control Panel** appears.

18. In the camera selection area at the top of the panel, tap the camera name.

If the camera initializes and connects, it has been successfully added and can be controlled.

Configure the Camera Paint Box Connection

Each camera paint box is connected to a camera control computer via a USB cable. You must configure the computer to interact with the Camera Paint Box.

DashBoard communicates with the Camera Paint Box through a service called the bridge server. To establish communication with the Camera Paint Box, you must:

1. Install the bridge server software
2. Add and configure a DashBoard gateway for the Camera Paint Box

To install the bridge server software:

1. Obtain the **Bridge Server** software zip file from Ross Video, and save it on the camera control computer.
2. Unzip the file to **C:\Ross**.
3. Open a command prompt window as **Administrator**, and change directory to the location where you unzipped the file, for example:

```
cd "C:\Ross\Bridge Server 4.5.0.4093"
```

4. Type the command to install the **ManagedServicesHost.exe** file and then press **Enter**. An example of the command is as follows:

```
C:\> "Ross\Bridge Server 4.5.0.4093\ManagedServicesHost.exe" -install
```

5. Press **Enter**.

The Bridge Server software is installed. A message in the command prompt window appears when the installation is complete.

6. Close the command prompt window.
7. In a web browser, navigate to the Bridge Server configuration page at **localhost:3000**.
8. If the **PaintBox Bridge** service is not running, tap **Start**.

Tip: From the configuration page, you can start or stop the server. Alternatively, you can start or stop the **Bridge Service Host** from the **Services** tab in **Windows Task Manager**.

To add and configure a DashBoard gateway for the Camera Paint Box

1. In DashBoard, from the **File** menu, tap **New**, and then tap **TCP/IP DashBoard Connect or openGear Device**.
The **New TCP openGear Frame Connection** dialog box appears.
2. In the **IP Address** box, type the IP address of the computer, or type `localhost`.
3. In the **Display Name** box, type a name for the node as you want it to appear in the DashBoard component tree, for example, **Robotics DashBoard Gateway**.
4. Select the **JSON** protocol.

5. In the **Port** box, type **5257**.
6. Select the **Remember connection settings for this frame** check box.
7. Tap **Finish**.

A new gateway node with the name you specified appears in the DashBoard component tree.

Tip: After you complete this procedure, you can expand the gateway node and double-tap **Station 1** to open an interface that displays real-time data received from the Camera Paint Box.

8. In the DashBoard component tree, expand the **DashBoard Services** node.
9. Tap **Device Class Mappings**.
10. For each **Class**, in the **Selected Device** list, select the only available option in the list.
11. In the DashBoard component tree, tap **Selector UI Mappings**.
12. Set the **Autowire Follows UI** setting to **ON**.

Install the Camera Video Monitor(s) and Routing/Switching Equipment

Each workstation requires at least one video monitor to view camera output. The monitor enables you to see on-screen camera configuration menus and monitor the effect of iris and paint adjustments as you make them. Sometimes two monitors are used, to compare video output of two cameras side-by-side.

Video routing/switching equipment is required to select the video. Ideally, the camera control operator should be able to switch the video from the camera control workstation.

Note: The camera video monitor and routing equipment operate independent of the Camera Control System. The Camera Control Panel and Camera Paint Box do not select video to be displayed on the camera video monitor.

When adjusting paint controls, technicians often use a waveform/vectorscope to fine-tune the properties of the camera output. The Camera Control Panel enables you to access the camera's color bars output for calibration purposes.

The camera video monitor, video routing equipment, and waveform/vectorscope are not included as part of the Panasonic Camera Control System.

To install the Camera Video Monitor(s) and Video Routing/Switching Equipment

1. Install the Video Routing / Switching Equipment.
2. Install the video monitor(s) in the camera control workstation(s).
3. Connect video cables between the camera video monitors and outputs on the routing/switching equipment.
4. Connect video cables from each camera to an input on the routing/switching equipment.
5. Configure the video routing/switching equipment so it is possible to route video from each camera to each camera video monitor.

