

X650 PT Head (side angle view)

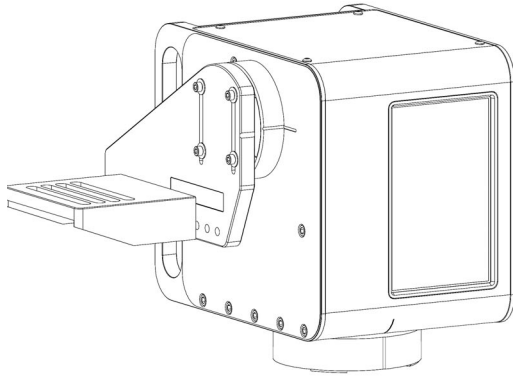

X350 PT Head (front angle view)

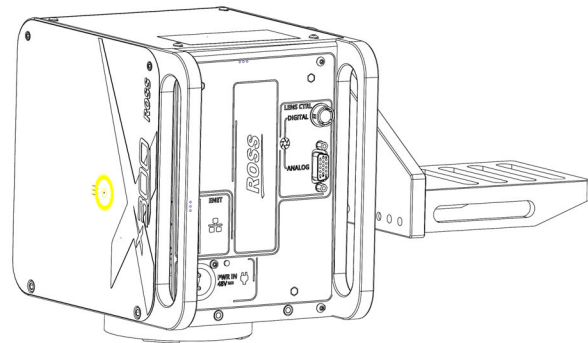

X300 PT Head (back angle view)

X-Series Pan & Tilt Heads

Technical Manual

Thank You for Choosing Ross

You've made a great choice. We expect you will be very happy with your purchase of Ross Technology. Our mission is to:

1. Provide a Superior Customer Experience
 - offer the best product quality and support
2. Make Cool Practical Technology
 - develop great products that customers love

Ross has become well known for the Ross Video Code of Ethics. It guides our interactions and empowers our employees. I hope you enjoy reading it below.

If anything at all with your Ross experience does not live up to your expectations be sure to reach out to us at solutions@rossvideo.com.



David Ross
CEO, Ross Video
dross@rossvideo.com

Ross Video Code of Ethics

Any company is the sum total of the people that make things happen. At Ross, our employees are a special group. Our employees truly care about doing a great job and delivering a high quality customer experience every day. This code of ethics hangs on the wall of all Ross Video locations to guide our behavior:

1. We will always act in our customers' best interest.
2. We will do our best to understand our customers' requirements.
3. We will not ship crap.
4. We will be great to work with.
5. We will do something extra for our customers, as an apology, when something big goes wrong and it's our fault.
6. We will keep our promises.
7. We will treat the competition with respect.
8. We will cooperate with and help other friendly companies.
9. We will go above and beyond in times of crisis. *If there's no one to authorize the required action in times of company or customer crisis - do what you know in your heart is right. (You may rent helicopters if necessary.)*

Technical Manual for X-Series Pan & Tilt Heads

- Ross Part Number: **5100DR-082-03**
- Release Date: July 17, 2025.
- Software Issue: Furio Firmware v6.0d

The information contained in this manual is subject to change without notice or obligation.

Copyright

© 2025 Ross Video Limited. Ross® and any related marks are trademarks or registered trademarks of Ross Video Limited. All other trademarks are the property of their respective companies. PATENTS ISSUED and PENDING. All rights reserved. No part of this publication may be reproduced, stored in a retrieval system, or transmitted in any form or by any means, mechanical, photocopying, recording, or otherwise, without the prior written permission of Ross Video. While every precaution has been taken in the preparation of this document, Ross Video assumes no responsibility for errors or omissions. Neither is any liability assumed for damages resulting from the use of the information contained herein.

Patents

Ross Video products are protected by patent numbers US 7,034,886; US 7,508,455; US 7,602,446; US 7,802,802 B2; US 7,834,886; US 7,914,332; US 8,307,284; US 8,407,374 B2; US 8,499,019 B2; US 8,519,949 B2; US 8,743,292 B2; GB 2,419,119 B; GB 2,447,380 B. Other patents may apply or be pending.

Company Address and Contact Information



Ross Video Limited
8 John Street
Iroquois, Ontario
Canada, K0E 1K0

Ross Video Incorporated
P.O. Box 880
Ogdensburg, New York
USA 13669-0880

General Business Office: (+1) 613 • 652 • 4886

Fax: (+1) 613 • 652 • 4425

Toll Free Technical Support: 1-844-652-0645 (North America)
+800 1005 0100 (International)

Technical Support: (+1) 613 • 652 • 4886

E-mail for Technical Support: techsupport@rossvideo.com

ROSS VIDEO | HELP CENTER: <https://support.rossvideo.com/hc/en-us>

E-mail for General Information: solutions@rossvideo.com

Ross Video Website: <http://www.rossvideo.com>

Contents

Welcome	6
Introducing the X-Series Pan & Tilt Heads	6
X300 and X350	6
X650 Heads	7
About Ross Robotics	7
Safety Notices and Regulatory Compliance Statements	8
Safety Notices	8
Regulatory Compliance Statements	10
Documentation Conventions	10
Interface Elements	10
Touch-Screen Support	10
User-Typed Text	10
Referenced Guides	10
Menu Sequences	11
Contacting Technical Support	11
Installing an X-Series Head	12
Unpacking an X300 or X350	12
Mounting and Assembling the Head	13
X300 or X350 PT Heads	13
Mount the Head	13
Attach the Camera Cradle	16
Mounting the Payload	17
Balancing the Payload	18
Cabling and Tethering	20
Use the Built-in Touchscreen to Configure the X350 Head Locally	21
Unpacking an X650	22
Mounting and Assembling the X650 Head	22
Attaching the Camera Cradle	22
Attaching the Furio Column Coupler	23
Mounting onto a Furio Column	24
Mounting without a Furio Column	24
Cabling the Head	26
Positioning Track Data (Optional)	26
Lens Control	26
Network	27
Power	27
Testing the Head	27
Configuring the IP Address	27
Testing the Head	27
Loading and Balancing	27
Preparing and Mounting the Payload	27
Balancing the Payload	27
Configuring X300, X350, and X650 Heads	29
Using DashBoard Walkabout to Assign Unique IP Addresses	29
Configuring X300, X350 and X650 Heads Remotely	30
Accessing the Web Interface	31
Configuring IP Settings (Network Settings)	32
Setting Persistent Axis Limits	32

Status and Logging	34
Configuring Tracking Data Output	36
Applying a Firmware Upgrade File	37
Downloading and Restoring a Data Backup File	38
Rebooting the Head	39
Changing the On-Air or Preview Image for SmartTally	40
Configuring and Operating X350 or X650 Heads Locally	41
Configuring Network Settings Locally (X350 and X650 only)	42
Operating Axes Locally (X350 and X650 only)	44
Setting Axis Limits Locally (X350 and X650 only)	47
Adding Heads to a Control System	50
Controlling the X300, X350, and X650 Heads	51
DashBoard Control (PT Head Control Plugin)	51
SmartShell Control	52
Furio API Control	53
Maintenance and Troubleshooting	54
Maintenance	54
Troubleshooting	55
Technical Specifications	56
Technical Specifications	56
Drawings of the X300 Pan & Tilt Head	57
Back (connection panel)	58
Front	59
Right Side (camera cradle side)	60
Left Side	60
Bottom	61
Top	62
Angled Views (X300 head, mounted on a PM8 pedestal riser)	63
Drawings of the X350 Pan & Tilt Head	64
Back (connection panel)	65
Front	66
Right Side (camera cradle side)	66
Left Side	67
Bottom	68
Top	69
Angled Views (X350 head mounted on a PM8 pedestal riser)	70
Drawings of the X650 Pan & Tilt Head	72
Back (connection panel)	73
Front	74
Right Side (camera cradle side)	75
Bottom	76
Top	77
Connector Pin Assignments	77
Digital Lens Control Port — Pin Assignments (X350 and X650 only)	78
Analog Lens Control Port — Pin Assignments	78
Serial Camera Control Port — Pin Assignments (X350 only)	79
Power Input — Pin Assignments	79
Power Output— Pin Assignments (X350 and X650 only)	80
Optional Mounting Accessories	81
PM8 Pedestal Riser for X300 or X350 (RRB-UNI-PM8)	81
Universal Ceiling Mount for X300, X350, or X650 (RRB-UNI-CLM)	82

Universal Wall Mount Bracket for X300 or X350 (RRB-UNI-WMB)	82
Mitchell Mount Adapter for X300, X350, or X650 (RRB-UNI-MA)	83
Tripods and Pedestals	83
Site Requirements	84
Camera and Lens Control Options	84
About Payload Design and Load Balancing	85
General Studio Requirements	85
Power and Networking Requirements	86

Welcome

This section contains the following topics:

- “Introducing the X-Series Pan & Tilt Heads”
- “About Ross Robotics”
- “Safety Notices and Regulatory Compliance Statements”
- “Documentation Conventions”
- “Contacting Technical Support”

Introducing the X-Series Pan & Tilt Heads

X300 and X350

X300 and X350 robotic pan & tilt heads are compact, affordable, and perfect for robotic camera applications where no prompter is required. With a 15 lb (6.8 kg) payload capacity, they can handle practically any ENG or box camera and lens combination. Based on decades of robotic pan & tilt head design experience, the X300 and X350 offer the smooth, accurate movement that you've come to expect from Ross Robotics, while also incorporating all of the advanced motion control benefits of MotionDirector technology, including keyframed moves (when controlled by SmartShell).

Figure 1 shows the X350 pan & tilt head.

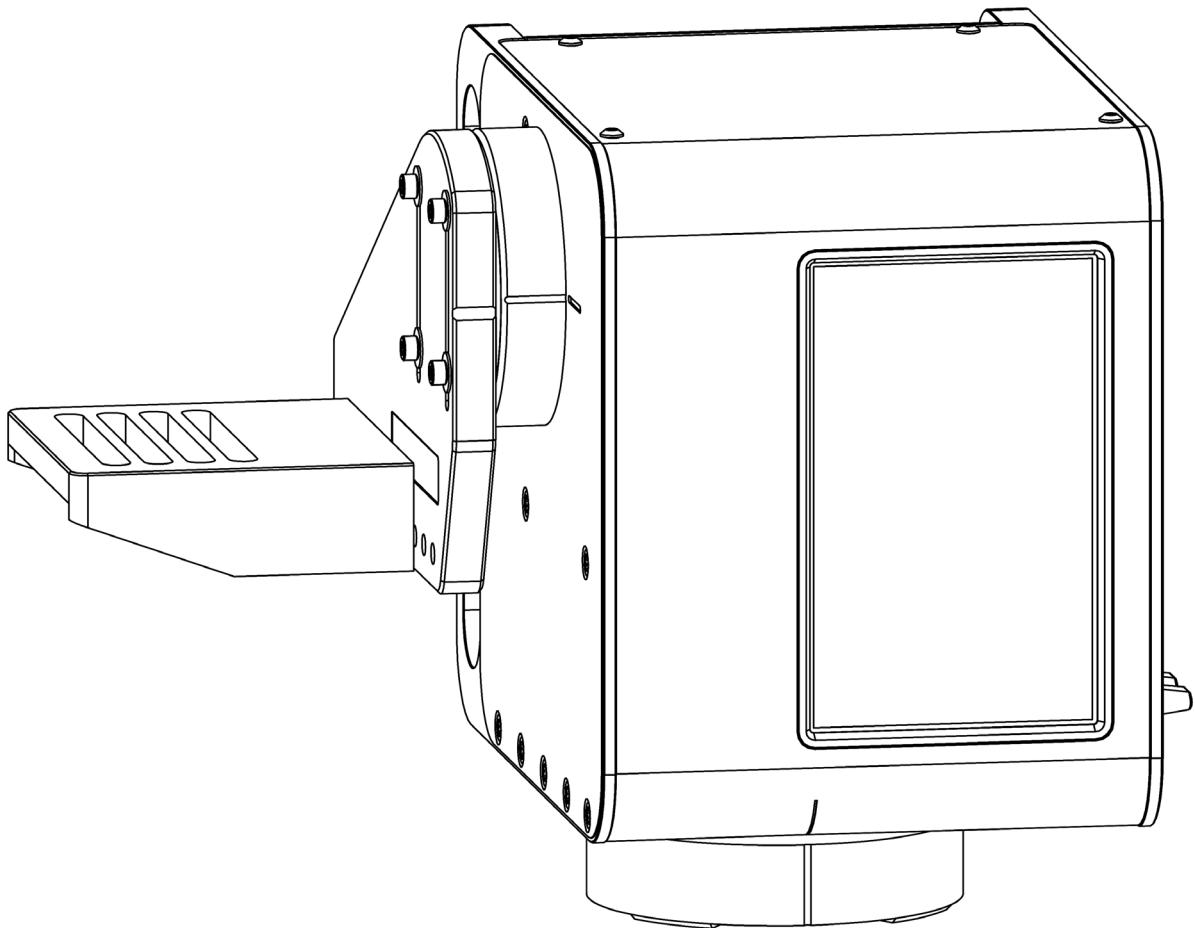

Figure 1 - Ross Robotics X350 Pan & Tilt Head (front view, showing touchscreen)

X650 Heads

X650 robotic pan & tilt heads are compact, affordable, and perfect for robotic camera applications. With a 125 lb (57 kg) payload capacity, they can handle practically any ENG or box camera and lens combination. Based on decades of robotic pan & tilt head design experience, the X650 offer the smooth, accurate movement that you've come to expect from Ross Robotics, while also incorporating all of the advanced motion control benefits of MotionDirector technology, including keyframed moves (when controlled by SmartShell).

Figure 1 shows the X650 pan & tilt head.

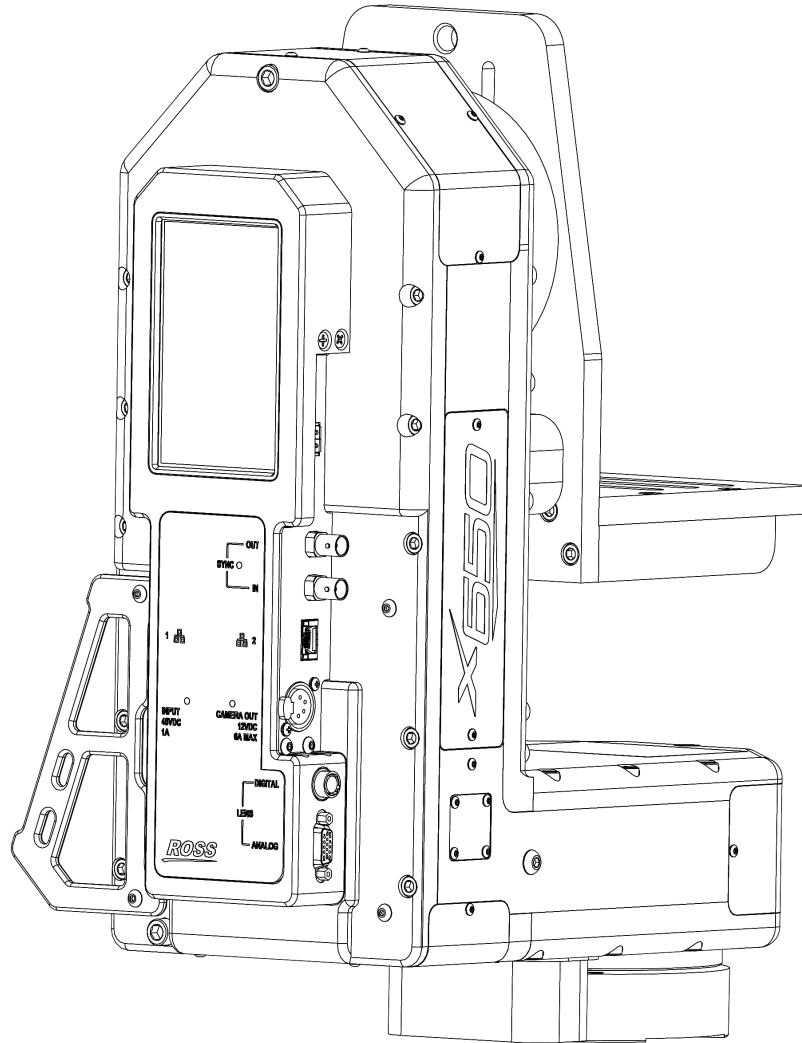

Figure 2 - Ross Robotics X650 Pan & Tilt Head (side view, showing touchscreen)

For detailed technical specifications and more drawings of the X-Series heads, see **“Technical Specifications”**.

About Ross Robotics

Ross Video has the most complete studio robotics offering available, whether you are looking for the unparalleled smoothness of a track-based system, the unbeatable flexibility of a free-roaming pedestal, or the simple efficiency of a standalone pan & tilt head. All Ross robotic systems are designed, developed and manufactured in-house, using state-of-the-art technologies that provide industry-leading accuracy,









precision, and payload capacity. Ross Video designs, manufactures, and sells a wide variety of camera motion systems to suit your needs.









Safety Notices and Regulatory Compliance Statements

This section contains important safety notices and regulatory compliance notices.

Safety Notices

Please read and observe the following safety notices.

 Caution	<p>This equipment must be operated by trained personnel only.</p> <p>This equipment must be operated in a controlled and restricted environment only.</p>
 Warning	<p>The safe operation of this product requires that a protective earth connection be provided. A grounding conductor in the equipment's supply cord provides this protective earth. To reduce the risk of electrical shock to the operator and service personnel, this ground conductor must be connected to an earthed ground.</p> <p>Use only power cords specified for this product and certified for the country of use.</p> <p>Do not defeat safety purpose of the grounding-type plug. A grounding type plug has two blades and a third grounding prong. The third prong is provided for your safety. If the provided plug does not fit in to your outlet, consult an electrician for replacement of the obsolete outlet.</p> <p>Protect power cord from being walked on or pinched, particularly at plugs, convenience receptacles, and points where they exit from the apparatus.</p>
 ESD	<p>ESD Susceptibility — This symbol on the equipment or within the equipment manual indicates that an electrical or electronic device or assembly is susceptible to damage from an ESD event.</p>
 Warning	<p>Hazardous Voltages — This symbol on the equipment or within the equipment manual indicates the presence of uninsulated “dangerous voltage” within the product enclosure that may be of sufficient magnitude to constitute a risk of shock to persons.</p>
 Warning	<p>Indoor Use —“WARNING – TO REDUCE THE RISK OF FIRE OR ELECTRIC SHOCK, DO NOT EXPOSE THIS APPARATUS TO RAIN OR MOISTURE”</p> <p>Do not use this apparatus near water.</p> <p>Do not block any ventilation openings. Install in accordance with manufacturer’s instructions.</p> <p>Do not install near heat sources such as radiators, heat registers, stoves, or other apparatus (including amplifiers) that produce heat.</p> <p>Only use attachments/accessories specified by the manufacturer.</p> <p>Unplug this apparatus during lightning storms or when unused for long periods of time.</p> <p>Clean only with a dry cloth.</p>
 Warning	<p>Refer all servicing to qualified personnel. Servicing is required when the apparatus has been damaged in any way, such as power-supply cord or plug damage; liquid has been spilled or objects have fallen into the apparatus; the apparatus has been exposed to rain or moisture, does not operate normally, or has been dropped.</p>
 Warning	<p>To reduce the risk of fire, replacement fuses must be the same type and rating.</p>
 Warning	<p>This product contains safety critical parts, which if incorrectly replaced may present a risk of fire or electrical shock. Components contained within the product’s power supplies and power supply area are not customer-serviceable and should be returned to the factory for repair.</p>

	Caution	Ensure that proper cable management techniques are used at all times. Bundle and wrap cables neatly, and provide adequate strain relief and slack where necessary. Test your cable installation by moving the robotic units through their entire range of motion slowly while observing the cables, to ensure that they do not become taut, or snag on anything. Avoid running cables along floors in places where they may present a tripping hazard. Clearly mark areas where cables may present a tripping hazard, and keep personnel away from such areas. Inspect cables periodically for damage, and to ensure that proper cable management is maintained.
	Warning	Damaged or improper cables may cause electric shock and/or fire. Ensure that all cables and connectors are of suitable type for their purpose, and that all power cable conductors are of adequate gauge for the voltage and current required. Inspect all cables periodically to check for damage. If a cable becomes damaged, turn off power to the system immediately, and then replace the damaged cable.
	Warning	Serious injuries can result from people tripping over equipment and cables. Methods of reducing such risks include, but are not limited to, the following: <ul style="list-style-type: none"> • Erect signs at studio entrances to remind people about tripping hazards and other studio hazards. • Train personnel about safety procedures and proper cable management techniques. • Show personnel and guests the locations of cables and equipment, and explain that robotic cameras and cables attached to them may move at any time. • Escort guests at all times while in the studio. • Ensure adequate lighting when working in the studio. • Mark safe paths and/or restricted areas, to keep people away from moving robots and potential tripping hazards.
	Caution	Loose or overtightened bolts may cause equipment damage. When servicing, tighten bolts to specified torque.
	Warning	Moving parts may present a pinching hazard. Keep all personnel away from robots when they are operational. When a robotic head or robotic lift column moves, fingers touching or near the unit or the payload may become pinched. When installing or adjusting the payload, ensure that power to the system is turned off.
	Warning	When servicing or moving equipment, always observe safe handling practices. Get help to move heavy items. Use safe lifting techniques. Follow all safety rules of your workplace.
	Caution	Loose payloads may slip, causing equipment damage and injury. Periodically check all fasteners that secure the payload, to ensure that they are tightened to specified torque. If the payload is loose or slips, ensure that it is properly balanced and secured before operating the robot.
	Warning	Improper mounting may cause equipment damage and serious injury. When mounting a robotic head to a surface or structure, use approved mounting equipment. Use fasteners that are rated for the total load, and are suitable for the material to which they are being fastened. Install safety tethers as required, to ensure that the payload and robot do not fall if the mount fails. Ensure that the mounting surface or structure is sturdy and capable of supporting the total load. Ensure that the mounting surface or structure is immobile and that it will not move when the robotic head moves.
	Caution	Imbalanced payloads may cause equipment damage and may present a tipping hazard. Ensure payloads are properly balanced both horizontally and vertically, around the tilt axis of the head. If you adjust a payload, always rebalance it.

Regulatory Compliance Statements

This section contains regulatory compliance statements.

FCC Statement

This equipment has been tested and found to comply with the limits for a Class A digital device, pursuant to part 15 of the FCC Rules. These limits are designed to provide reasonable protection against harmful interference when the equipment is operated in a commercial environment. This equipment generates, uses, and can radiate radio frequency energy and, if not installed and used in accordance with the instruction manual, may cause harmful interference to radio communications. Operation of this equipment in a residential area is likely to cause harmful interference in which case the user will be required to correct the interference at his own expense.

Canada Class A Statement

This Class A digital apparatus meets all requirements of the Canadian Interference-Causing Equipment Regulations

Cet appareil numérique de la Classe A Respecte toutes les exigences du Règlement sur le matériel brouiller du Canada.

CE Statement

Electromagnetic Compatibility Statement: Meets 2014/30/EU Directive

Low Voltage Directive: Meets 2014/35/EU Directive

Korea Class A Statement

이 기기는 업무용 환경에서 사용할 목적으로 적합성평가를 받은 기기로서 가정용 환경에서 사용하는 경우 전파 간섭의 우려가 있습니다.

Documentation Conventions

Special text formats are used in this manual to identify parts of the product or user interface, text that a user must type, or a sequence of menus and submenus that must be followed to reach a particular command.

Interface Elements

Bold text is used to identify a part of the physical product, or a user interface element such as a dialog box, menu item, or button. For example:

In the **Address** cell, type a unique IP address for the head.

Touch-Screen Support

This guide assumes you are using a touch-screen. The guide includes instructions to tap user interface elements. If you are using a mouse instead of a touch screen, click the mouse instead of tapping.

User-Typed Text

Courier text is used to identify text that a user must type. For example:

In the **File Name** box, type `Channel102.property`.

Referenced Guides

Italic text is used to identify the titles of referenced guides, manuals, or documents. For example:

Quick Start Guide for X300 and X350 (5100DR-081-xx).

Menu Sequences

Menu arrows are used in procedures to identify a sequence of menu items that you must follow. For example, if a step reads, "**Server** > **Save As**," you would tap the **Server** menu and then tap **Save As**.

Contacting Technical Support

At Ross Video, we take pride in the quality of our products, but if problems occur, help is as close as the nearest telephone.

Our 24-hour Hot Line service ensures you have access to technical expertise around the clock. After-sales service and technical support is provided directly by Ross Video personnel. During business hours (Eastern Time), technical support personnel are available by telephone. After hours and on weekends, a direct emergency technical support phone line is available. If the technical support person who is on call does not answer this line immediately, a voice message can be left and the call will be returned shortly. This team of highly trained staff is available to react to any problem and to do whatever is necessary to ensure customer satisfaction.

- **Technical Support:** (+1) 613-652-4886
- **Toll-Free Technical Support:** 1-844-652-0645 (North America) or +800 1005 0100 (International)
- **ROSS VIDEO | HELP CENTER:** <https://support.rossvideo.com/hc/en-us>
- **E-mail:** techsupport@rossvideo.com
- **Website:** <http://www.rossvideo.com>

Installing an X-Series Head

This section describes how to install an X300, X350, or X650 robotic pan & tilt head. Before you install any heads, we recommend you review “**Site Requirements**”.

Tip: If the head(s) you are installing are model X350 or X650, you can configure them locally as you install them, or you can configure them remotely afterwards. If you want to configure the X350 heads as you install them, you must first either configure DHCP on your network or know what static IP address you want to assign to each X350 head.

IMPORTANT: Perform all procedures in the order presented.

For the X300 or X350, this section includes the following topics:

- “**Unpacking an X300 or X350**”
- “**Mounting and Assembling the Head**”
- “**Mounting the Payload**”
- “**Balancing the Payload**”
- “**Cabling and Tethering**”

For the X650, this section includes the following topics:

- “**Unpacking an X650**”
- “**Mounting and Assembling the X650 Head**”
- “**Mounting onto a Furio Column**”
- “**Cabling the Head**”
- “**Testing the Head**”
- “**Loading and Balancing**”

After you install one or more heads, you must configure them. For more information, see “**Configuring X300, X350, and X650 Heads**”.

Unpacking an X300 or X350

Unpack the head and check that the following components are present:

- X300 or X350 robotic pan and tilt head (X300: **5110AR-372-xx**, X350: **5110AR-365-xx**)
- Camera cradle attachment (**5100AR-383-xx**)
- Kit with three 3/8-16 and 1/4-20 camera screws in multiple lengths (1/2”, 5/8”, 1”) with washers (**5110KR-203-xx** for X300, **5110KR-242-xx** for X350).
- **Note:** Use the appropriate type based on your camera’s mounting thread.
- Bag of four M5 18 mm cradle mount screws and washers (**5110KR-039-xx**)
- One of the following lens control cables, as selected when the head was ordered):
 - › For digital Fujinon RD/ZD drives (10-pin at lens): Ross order code **RRB-UNI-DLF10**.
A tag on the cable reads **5100CR-759-xx**.
 - › For digital Fujinon RD/ZD drives (20-pin at lens): Ross order code **RRB-UNI-DLF20**.
A tag on the cable reads **5100CR-029-xx**.
 - › For digital Canon IASE drives (20-pin at lens): Ross order code **RRB-UNI-DLC**.
A tag on the cable reads **900-212-xx**.

- › For analog control of Canon (KTS or compatible) or Fujinon (BMD or compatible) lenses: Ross order code **RRB-UNI-ALC** (universal analog lens control cable).
A tag on the cable reads **5110CR-146-xx**.
- AC power adapter and line cord suitable for your location (based on shipping address or special request)

Retain all packaging materials in case you need to ship the head later.

Mounting and Assembling the Head

X300 or X350 PT Heads

This section describes how to mount an X300 or X350 head, and attach the camera cradle.

Before you begin, record the serial number from the underside of the head (see **Figure 3** on **page 13**). You may need it later to configure the head.

Mount the Head

A variety of mounting accessories are available from Ross Video. For more information, see **“Optional Mounting Accessories”**.

The bottom of the head has four mounting holes (1/4-20, 3/4" (19 mm) maximum penetration depth). See **Figure 3** for spacing details.

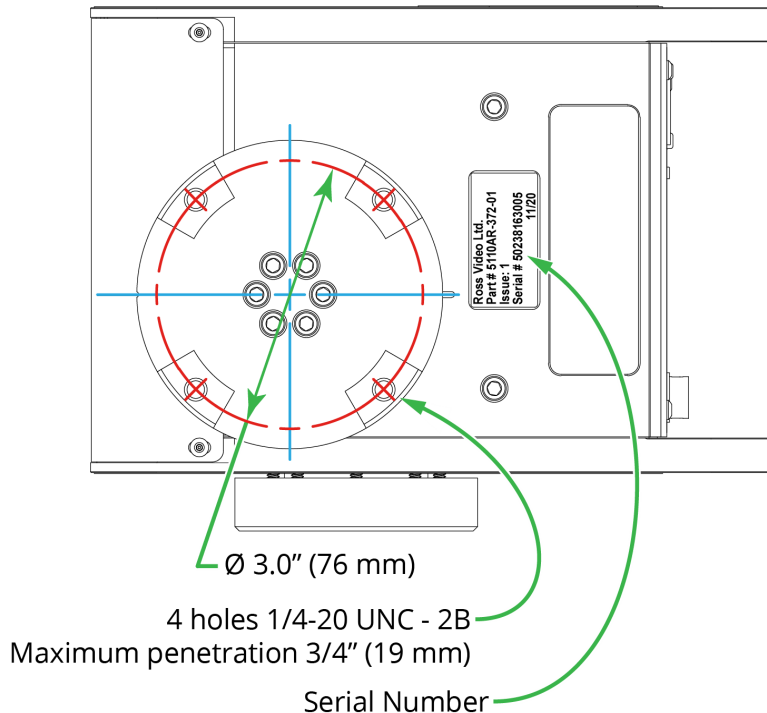

Figure 3 - Bottom of an X300 Head, showing Mount Hole Spacing

To mount the head:

1. Find the orientation mark on the **Pan** axis hub and note whether it is aligned with a similar mark at the front of the head (**Figure 4**). The front is the side that is opposite from the connection panel.
If the two marks are not approximately aligned, gently and slowly turn the **Pan** axis hub by hand to align the marks. They do not need to be perfectly aligned.

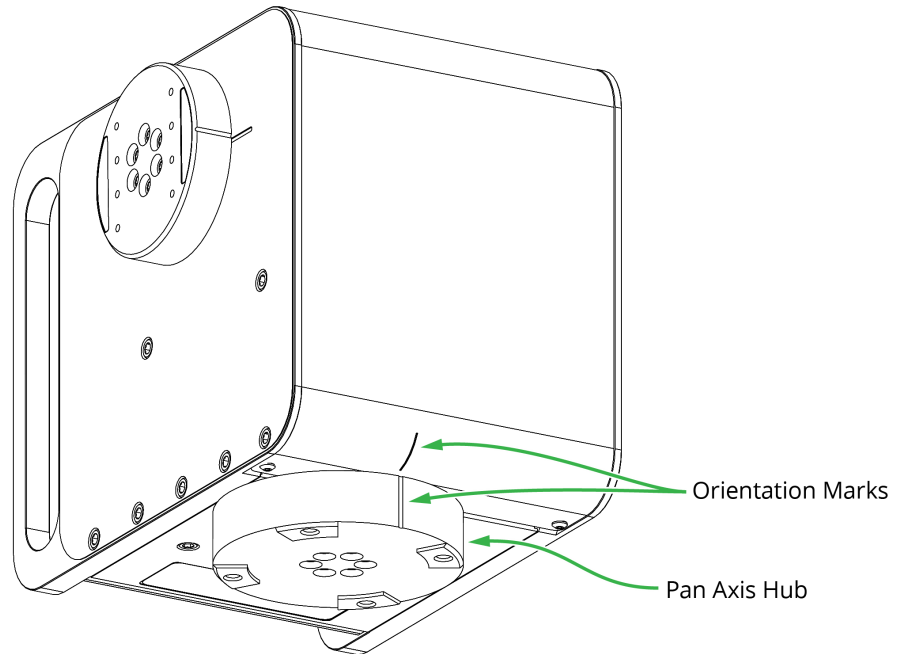

Figure 4 - X300, showing Pan Axis Orientation Marks

2. Fasten the head to the mount using four head mount screws (included with **PM4** or **PM8**).
Use a 3/16" hex key (Allen key).

IMPORTANT: Point the front of the head towards the set or the scene you want to record on video.

Figure 5 illustrates how to mount the head on a PM8 Pedestal Riser (RRB-UNI-PM8).

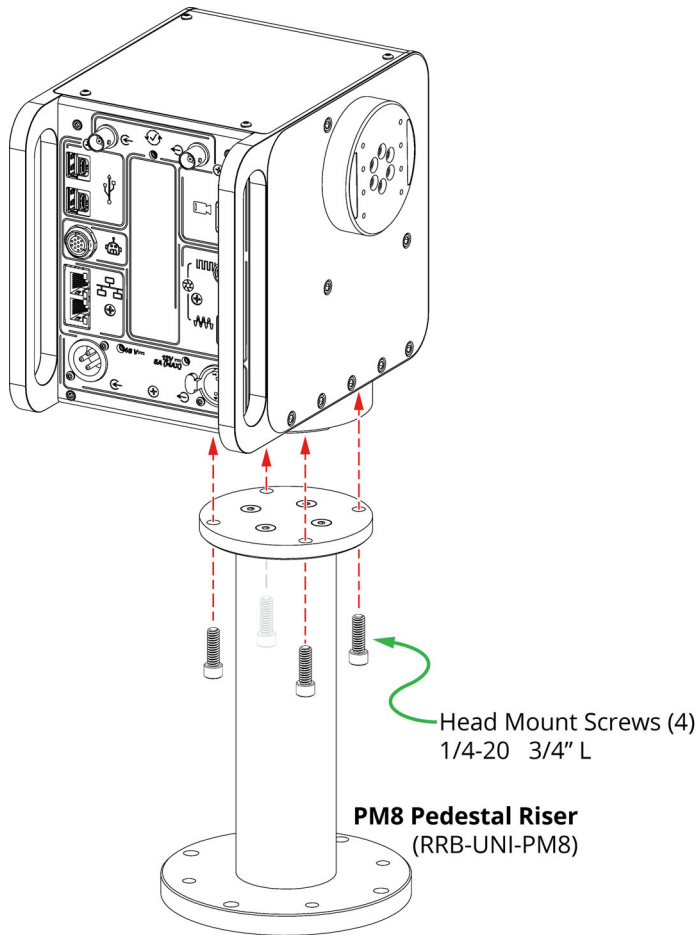

Figure 5 - Mounting an X350 Head on a PM8 Pedestal Riser

3. If the head is an X350, ensure that the Ross logo badge on the side of the head is upright. Rotate it if necessary.

The badge clicks into place.

The position of the badge controls the orientation of the X350 touch-screen display.

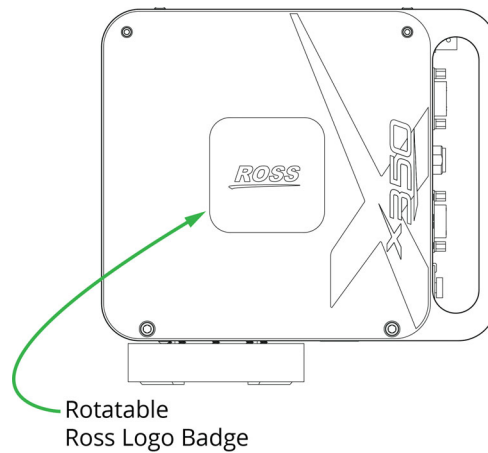

Figure 6 - Side View of an X350 Head, showing the Ross Logo Badge

Attach the Camera Cradle

The camera cradle attached to the Tilt hub of the X300 or X350 head.

To attach the camera cradle:

1. Find the orientation mark on the **Tilt** axis hub and note whether it is aligned with a similar mark pointing towards the front of the head (**Figure 7**). The front is the side that is opposite from the connection panel.

If the two marks are not approximately aligned, gently and slowly turn the **Tilt** axis hub by hand to align the marks. They do not need to be perfectly aligned.

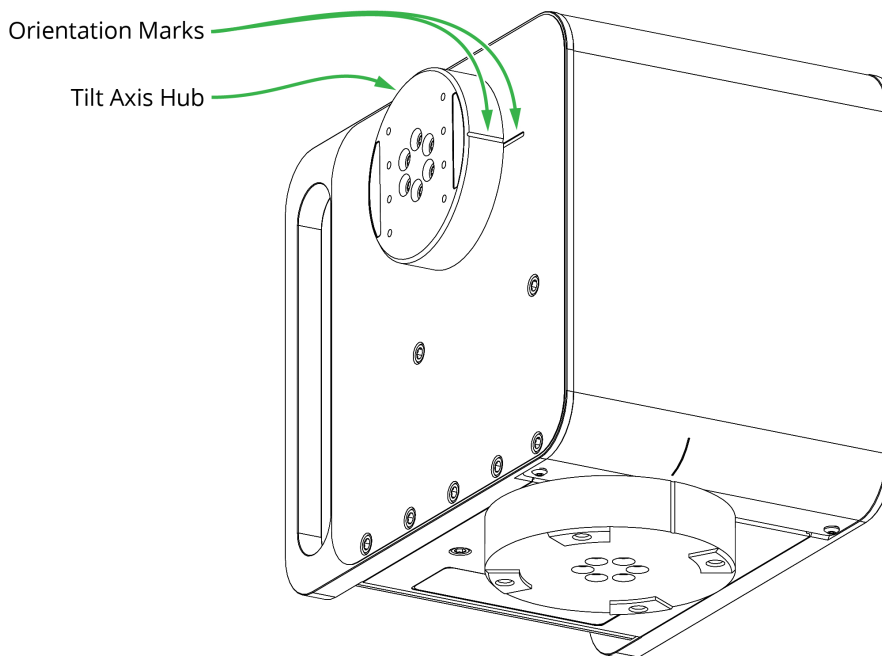

Figure 7 - X300, showing Tilt Axis Orientation Marks

2. Fasten the camera cradle to the head using four cradle mount screws and washers (bag 5110KR-039-xx).

Use an 8 mm flat wrench to drive the screws.

Figure 8 on **page 17** illustrates how to attach the camera cradle.

Tip: The exact camera cradle position is not critical. You may need to adjust it later to balance the payload.

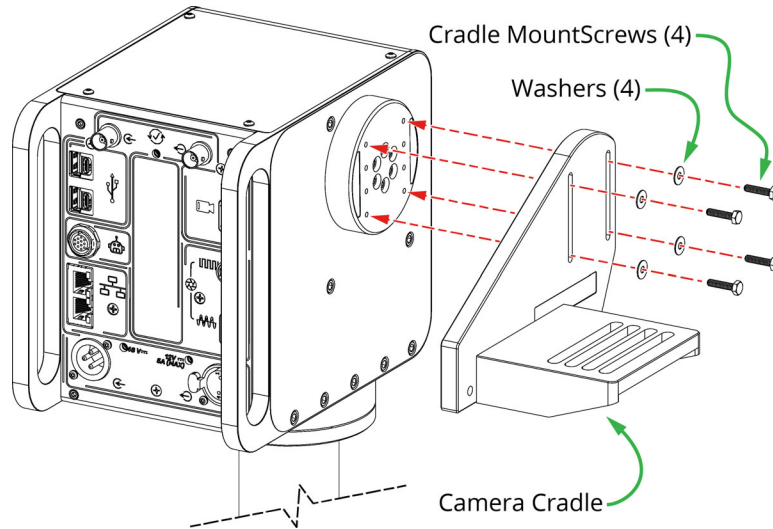

Figure 8 - Attaching the Camera Cradle

Mounting the Payload

This section describes how to assemble the payload and mount it on the camera cradle.

To assemble and mount the payload:

1. Attach the lens and other payload components to the camera.
2. Check the total payload weight.

IMPORTANT: Maximum payload is 15 lbs (6.8 kg).

3. Fasten the camera to the camera cradle using two camera screws and washers, depending on your camera's mounting thread.
Use the 1/4-20 screws (5110KR-040-xx) with a 3/16" hex key (Allen key), or the 3/8-16 screws (5110KR-030-01) with an 5/16" hex key.

Figure 9 on **page 18** illustrates how to mount the payload.

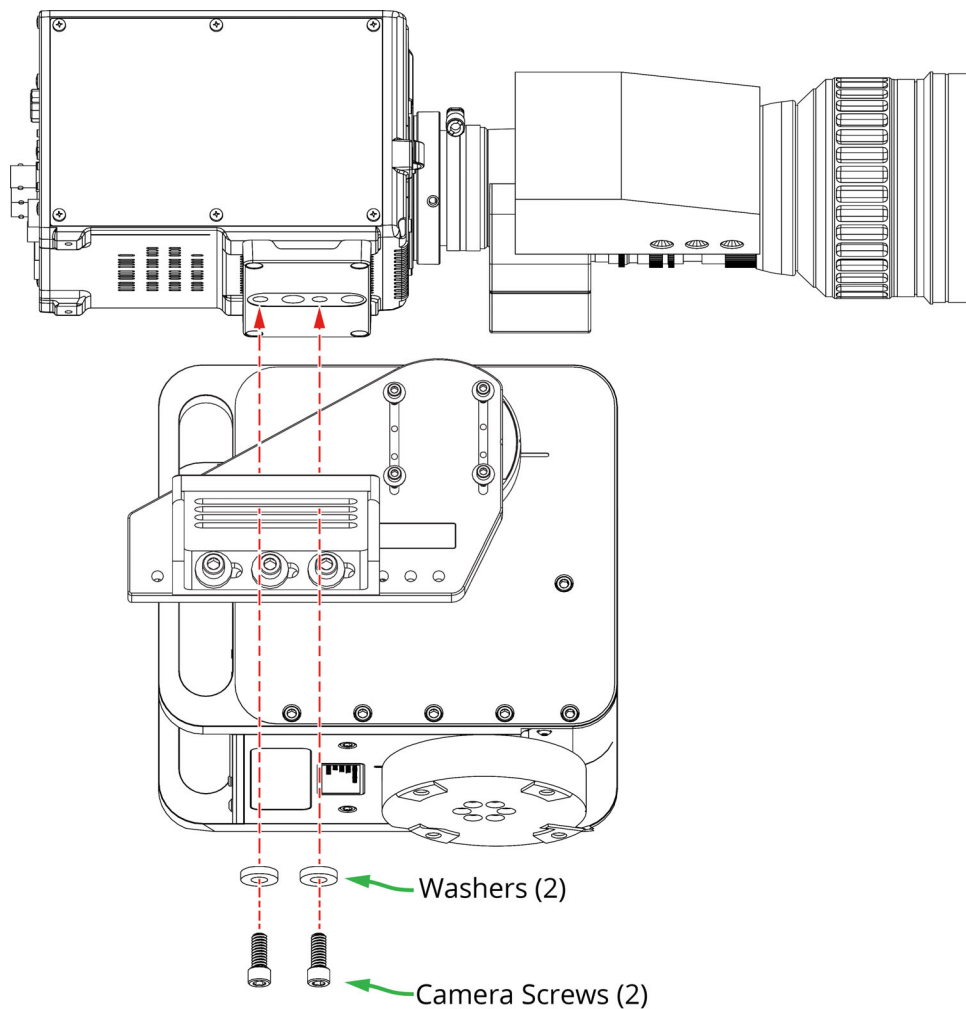

Figure 9 - Mounting the Payload

IMPORTANT: After you mount the payload, you must balance it! For more information, see “Balancing the Payload”.

Balancing the Payload

For best performance, and to reduce wear on the head’s drive train, you must ensure that the payload’s center of gravity is aligned with the tilt axis. You must balance the payload horizontally, and then vertically.

This section describes how to balance the payload. Perform the procedures in this section when installing a new X300 or X350 head, and whenever you replace, add, or reposition any payload components.

The head and camera cradle are designed to make balancing easy. **Figure 10** illustrates the following payload balancing adjustment features:

- Three screws along the bottom edge of the camera cradle fasten the cradle pieces together, and allow for horizontal adjustment (forwards / backwards):
 - › A series of threaded holes allow the screws to be repositioned for major horizontal adjustments.
 - Tip:** When repositioning the screws, be careful to avoid losing washers.
 - › Slots allow for horizontal fine-tuning.

IMPORTANT: Be sure to tighten the three screws that fasten together the camera cradle pieces. These screws are shipped partially-loose.

- Four M5 screws that join the camera cradle to the head (8 mm flat wrench required) allow for vertical adjustment (up / down):
 - › A series of threaded holes allow the screws to be repositioned for major vertical adjustments.
 - Tip:** When repositioning the screws, be careful to avoid losing washers.
 - › Vertical slots on the camera cradle allow for vertical fine-tuning.
- IMPORTANT:** Always use four screws to fasten the camera cradle to the head (two per slot).

IMPORTANT: An overweight or improperly balanced payload can cause permanent damage to the head.

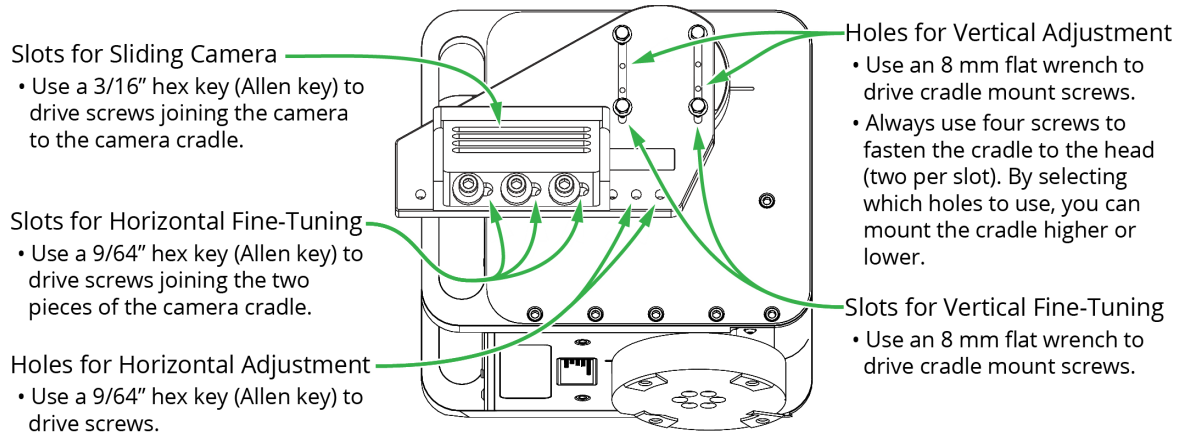

Figure 10 - Payload Balancing Adjustment Features

To balance the payload horizontally:

1. Ensure that power to the head is disconnected.
2. Manually tilt the payload so that it is horizontal, and then release it.
3. If the payload does not tilt, it is horizontally balanced. Skip the remaining steps, and proceed to the next procedure.
4. Use the horizontal adjustment features (see **Figure 10** on **page 19**) to move the payload away from the direction it tilted, and then test again.
5. Continue adjusting and testing until the payload is horizontally balanced.
 - Tip:** After you balance the payload horizontally, use a grease pencil or marker to mark the position of the payload on the camera cradle.

To balance the payload vertically:

1. Manually tilt the payload approximately 40° (but not as far as it can go), and then release it.
2. If the payload does not move, it is vertically balanced. Skip the remaining steps in this procedure.
3. Based on the direction the head tilts, note whether it needs to be raised or lowered:
 - If the payload tilts back towards horizontal, it is mounted too low, and must be raised.
 - If the payload continues tilting away from horizontal, it is mounted too high, and must be lowered.
4. Use the vertical adjustment features (see **Figure 10** on **page 19**) to raise or lower the payload as required, and then test again.
 - Tip:** If you cannot easily access the vertical adjustment screws, you may need to temporarily remove the payload from the camera cradle. Be sure to return it to its original horizontal position.
5. Continue adjusting and testing until the payload is vertically balanced.
 - Tip:** After you balance the payload vertically, use a grease pencil or marker to mark the position of the cradle mount screws on the cradle.

Cabling and Tethering

Connect and dress cables, and then attach safety tethers.

Figure 11 illustrates cable connections on the X350 head. The X300 is similar, but with fewer connectors, as noted.

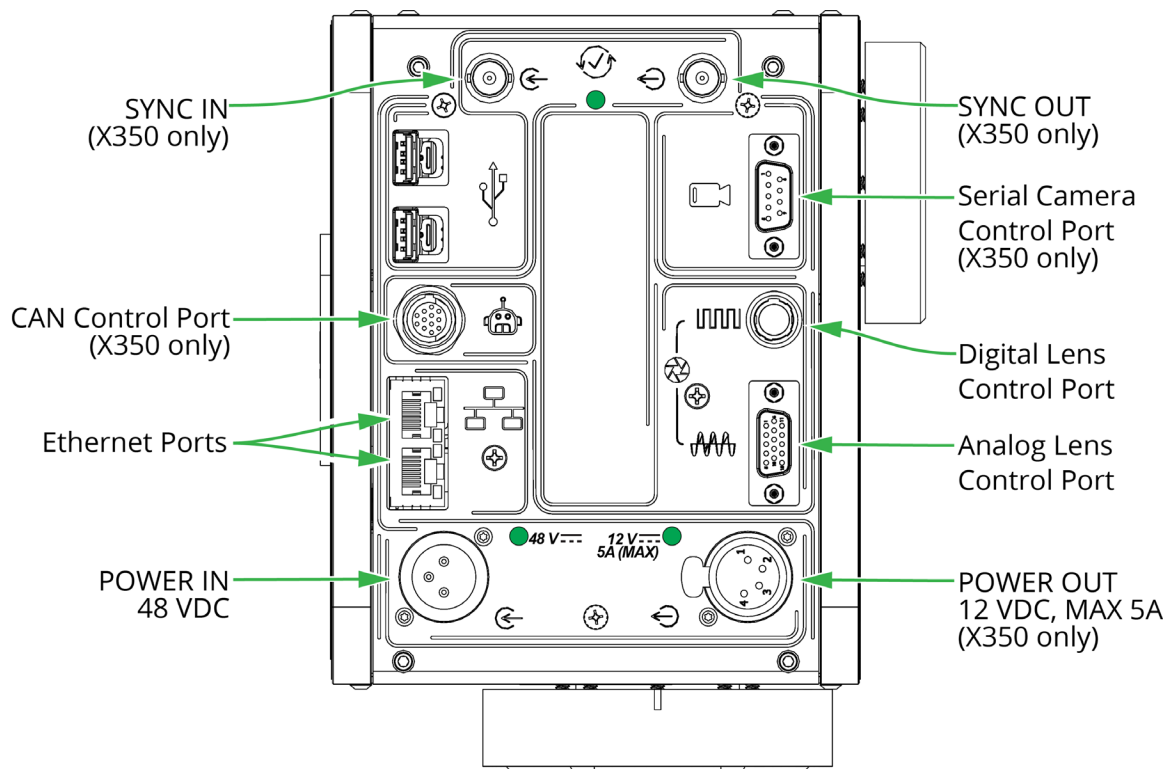

Figure 11 - Cabling the X350 Head

To cable an X300 or X350 head:

1. Connect a CAT5E cable from the Ethernet network to one of the two **Ethernet Ports** on the head.
2. If camera control over IP is required, connect a CAT5E cable from an **Ethernet Port** to the camera.
Tip: If the camera can be controlled both over IP and through a serial digital connection, and you want to cascade the network connection from head-to-head, use the **Serial Camera Control Port** for camera control. This leaves both Ethernet ports available for daisy-chaining the network connection.
3. If there is a vacant **Ethernet Port** and you want to cascade the network connection from head to head, connect a CAT5E cable between the **Ethernet Port** and an **Ethernet Port** on the next head.
4. If the head is a model X350 and is mounted on a Furio dolly, Furio SkyDolly, or Furio BlackBird pedestal, connect a CAN data cable from the control network to the **CAN Control Port** on the X350 head.

Tip: The control network connection is typically via the connection panel of a Furio Dolly, SkyDolly, or BlackBird pedestal).

Note: CAN bus communication requires **firmware v6.0.200** (minimum) to be installed on the X350 head.

5. If lens control is analog, connect a suitable lens control cable from the **Analog Lens Control Port** to the lens.
6. If lens control is digital, connect a suitable lens control cable from the **Digital Lens Control Port** to the lens.
7. If the head is a model X350 and serial camera control is required, connect a suitable serial cable from the **Serial Camera Control Port** to the camera.

8. If the head is a model X350 and a sync signal is available, connect the sync cable to the **SYNC IN** port (standard BNC).
Tip: You can also provide the sync signal to another device, such as a camera or robotic head, via the **SYNC OUT** port (standard BNC).
9. If the head is a model X350 and you want to provide 12 VDC power from the head to the camera, connect the camera's power cable to the **POWER OUT** port on the head. Maximum current is 5 Amps. Maximum power is 60 Watts.
10. Connect the power adapter cable to the **POWER IN** port on the head.
11. Dress all cables carefully to
 - allow the full range of pan & tilt motion without snagging, or obscuring the camera lens.
 - prevent strain on cable connections, by attaching cables to the head's handles (**Figure 12**). Minimize drag by tying cables to a fixed support close to the head, and by keeping the unsupported cable swag short.

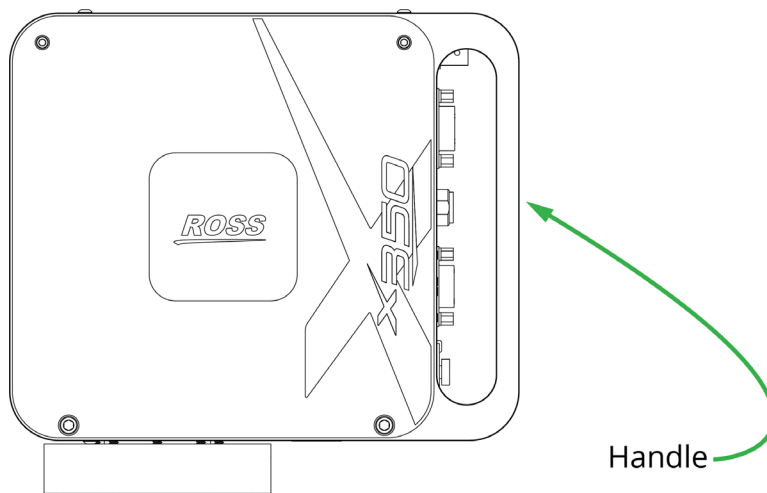

Figure 12 - Side View of an X350 Head, showing a Handle

- prevent physical damage to the cables, such as can be caused by foot traffic, rolling equipment, etc.
 - prevent risk to personnel such as can be caused by tripping over poorly-dressed cables.
12. Attach any required safety tethers, looping them through both handles or through only the handle on the payload side of the head (preferred).
Ensure all tethers allow full pan & tilt motion without excess slack, and without obscuring the camera lens.
Do not dress (bundle or zip-tie) safety tethers!
 13. Connect the line cord to the power adapter, and then plug it into a suitable electrical socket.
IMPORTANT: Whenever you disconnect power to the X300 head, wait at least 20 seconds before reconnecting it. Otherwise, the head may not start properly.

Use the Built-in Touchscreen to Configure the X350 Head Locally

The X350 head features a built-in touchscreen interface that enables you to configure network connectivity and set axis limits locally.

If you plan to use DHCP to assign IP addresses dynamically, or you know the static IP address you want to assign to each X350 head, you can configure network connectivity settings for the heads as you install them. You can also set persistent and temporary axis limits.

Alternatively, you can perform configuration tasks remotely, using DashBoard and a web interface.

For more information about using the X350 touchscreen, see **“Configuring and Operating X350 or X650 Heads Locally”**.

Unpacking an X650

Unpack the head and check that the following components are present:

- X650 robotic pan and tilt head (X300: **5110AR-096-xx**)
- 600 Series Cradle Kit (**5110KR-066-xx**).
- Head mounting kit with four 3/8-16 x 1-1/4 screws (**5110KR-100-01**).
- Kit for the 48V 160W power supply (**5110KR-217-01**).
- Furio Mounting Kit: Contains V3 Coupling for mounting (**5110KR-100-xx**).
- Bag of 5/8-16 x 1" camera mount screws and washers (**5110KR-030-xx**)
- One of the following lens control cables, as selected when the head was ordered):
 - › For digital Fujinon RD/ZD drives (10-pin at lens): Ross order code **RRB-UNI-DLF10**.
A tag on the cable reads **5100CR-759-xx**.
 - › For digital Fujinon RD/ZD drives (20-pin at lens): Ross order code **RRB-UNI-DLF20**.
A tag on the cable reads **5100CR-029-xx**.
 - › For digital Canon IASE drives (20-pin at lens): Ross order code **RRB-UNI-DLC**.
A tag on the cable reads **900-212-xx**.
 - › For analog control of Canon (KTS or compatible) or Fujinon (BMD or compatible) lenses: Ross order code **RRB-UNI-ALC** (universal analog lens control cable).
A tag on the cable reads **5110CR-146-xx**.
- AC power adapter and line cord suitable for your location (based on shipping address or special request)

Retain all packaging materials in case you need to ship the head later.

Mounting and Assembling the X650 Head

This section describes how to mount an X650 head, and attach the camera cradle.

Before you begin, record the serial number from the underside of the head (see **Figure 3** on **page 13**). You may need it later to configure the head.

Attaching the Camera Cradle

1. Fasten the cradle to the head using the four bolts and four washers provided.
2. The head has eight holes. Fasten two bolts into the top two holes, and two bolts into the bottom two holes. Do not over tighten.

See **Figure 3** for spacing details.

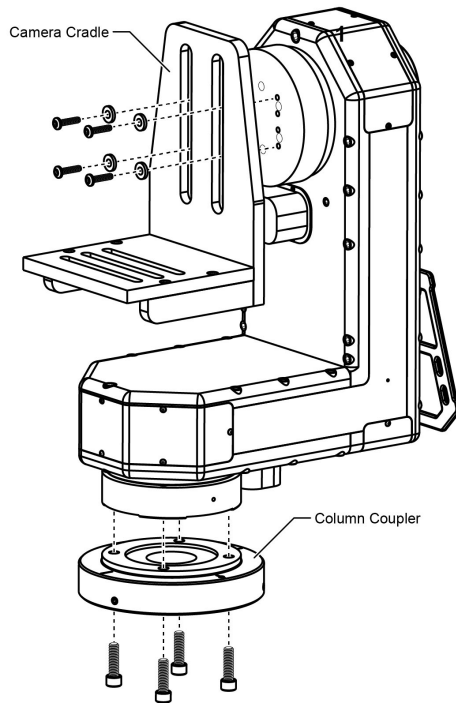

Figure 13 - Attaching an X650 to the camera cradle

Attaching the Furio Column Coupler

If you are using the X650 with a Furio column, attach the provided column coupler to the head.

1. Align the orientation mark on the coupler with the drilled orientation hole on the base of the head.
2. Fasten the coupler to the head using the four bolts provided. Do not overtighten.

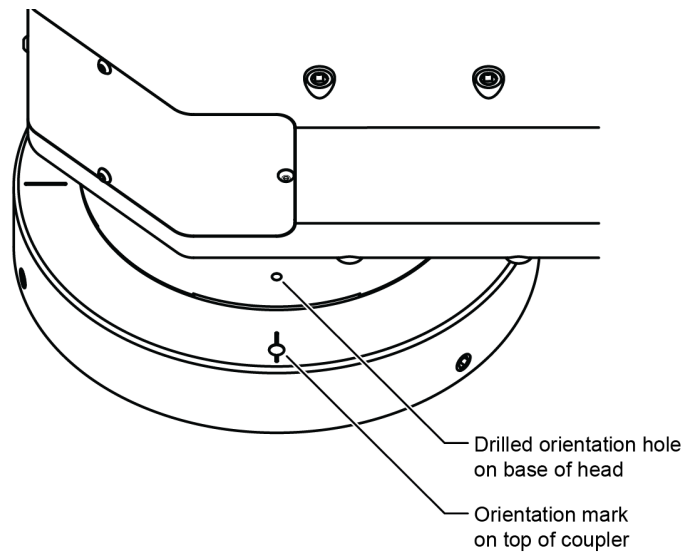

Figure 14 - Attaching an X650 to the Column Coupler

IMPORTANT: The coupling has two orientation marks (one for BlackBird Pedestal and the other for Furio Dollies). Ensure the X650's homing position faces in the direction of travel for the pedestal and perpendicular to the travel of the dolly.

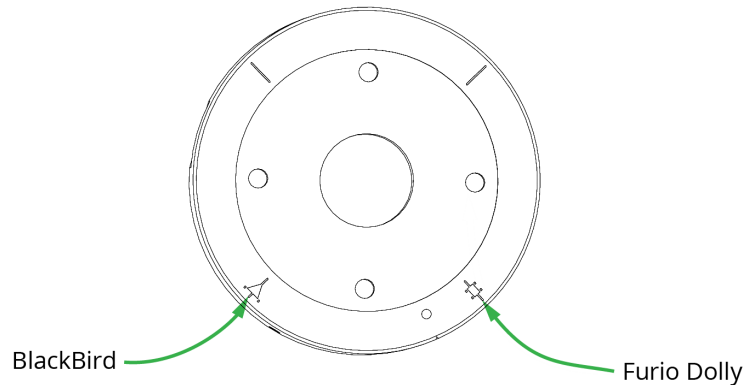

Figure 15 - Column Coupler Orientation Marks

Mounting onto a Furio Column

SAFETY NOTICE: Two people are required to lift and mount the head. The head is heavy and can cause injury and/or be damaged if dropped.

1. If the column is a lift column, lower it completely and turn off power to the system.
2. Note the orientation recess on the top of the column, and the corresponding flange on the bottom of the column coupler. These must align when you mount the head.
3. Keeping the head level at all times, lift the head onto the column.
4. Rotate the head until the orientation recess on the top of the column engages with the corresponding flange on the bottom of the column coupler. Ensure that the head is well seated on the column and does not rock.
5. Fasten the column coupler to the column by tightening the three set screws embedded in the edge of the coupler. Do not overtighten.

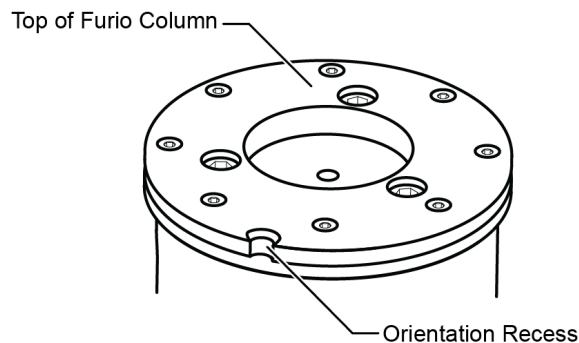

Figure 16 - Mounting an X650 onto a Furio Column

Mounting without a Furio Column

SAFETY NOTICE: Two people are required to lift and mount the head. The head is heavy and can

cause injury and/or be damaged if dropped.

1. Mount the head to the support apparatus using four bolts (3/8" 16 UNC) of suitable length.
2. Bolt penetration into the head is to be minimum 0.625" [16mm] and maximum 1.125" [29mm].

Cabling the Head

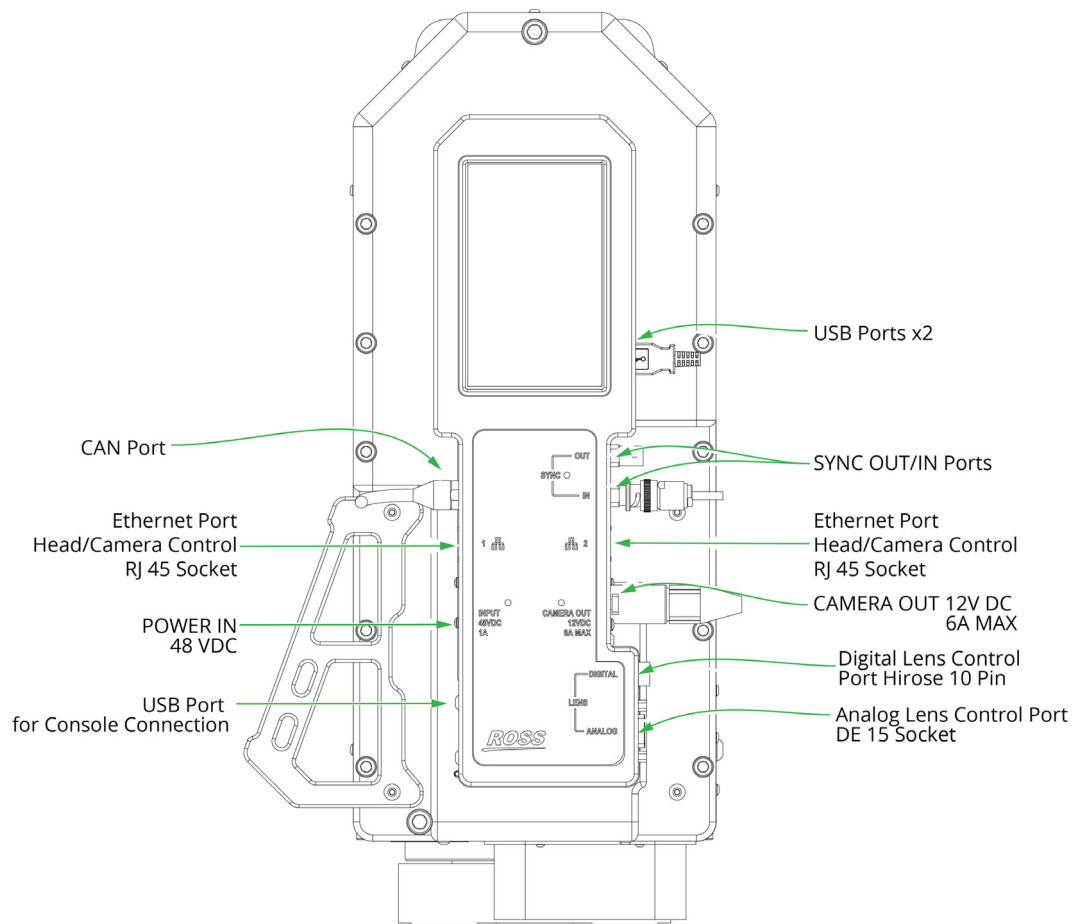

Figure 17 - Labeled Connections on an X650 PT Head

Positioning Track Data (Optional)

The X650 head emits synchronized position tracking data, which is used for virtual reality and augmented reality applications. The data can be synchronized with an external reference signal at 50Hz or 60Hz. If no external signal is provided, the head generates an internal 50Hz sync pulse and emits tracking data at a rate of 50 times per second (50Hz).

If you want the head to generate tracking data synchronized to an external reference signal, connect the reference signal to the **VIDEO SYNC** connector on the head.

Lens Control

1. If lens control is digital, connect a suitable lens control cable from the **Digital Lens Control Port** to the lens.
2. If lens control is analog, connect a suitable lens control cable from the **Analog Lens Control Port** to the lens.

Network

1. If you are using a Furio dolly, connect a Furio data cable between one of the **NETWORK** connectors on the head, and the middle **CAN** connector on the dolly.
2. Connect an Ethernet cable to the **ETHERNET** connector on the head, and to the network.

Power

Connect the head to the FRU power cable.

Note: The head does not have an **ON/OFF** switch. It starts when connected to power.

Testing the Head

Configuring the IP Address

1. Turn on the power supply to the head, and then turn on the SmartShell computer.
2. On the SmartShell computer, open Internet Explorer and navigate to <http://10.42.3.64>. The head configuration interface appears.
3. On the IP Settings tab, specify a new, unique IP address for the head.
4. Click Save and Reboot.

Testing the Head

1. On the SmartShell computer, start SmartShell by double-clicking SmartShell.exe.
2. Click the head's camera name at the top of the window, and then click Operate. SmartShell enables and homes the axes. This may take up to 30 seconds. If any fail to home, note the problem and click **SKIP**.
3. Using SmartShell and the Joystick Panel, test each axis of the head.

Loading and Balancing

Preparing and Mounting the Payload

SAFETY NOTICE: Two people are required to lift and mount the payload. The payload is heavy and can cause injury and/or be damaged if dropped.

1. Turn off power to the head, and then assemble the payload, including everything that will be mounted on the head.
2. Lift the load onto the head and fasten it down. Attach all cables. Bundle and fasten them to the cable bracket, allowing enough slack for head movement. Encase them in a suitable sleeve.

Balancing the Payload

To ensure optimal performance and reduce wear on the head's drive train, the payload must be properly balanced. This includes both horizontal (front to back) and vertical (height) alignment with the tilt axis. Perform this procedure whenever a new payload is installed or when components are added, removed, or repositioned.

Start by checking the horizontal balance to confirm that the payload's center of gravity aligns with the tilt axis. Gently tilt the cradle until the payload is horizontal, then release it. If the cradle does not begin to

tilt, the load is balanced horizontally. Otherwise, adjust the payload position until it is balanced. Once balanced, mark the payload's position precisely.

Next, check the vertical balance to ensure the payload remains stable at an angle. Gently tilt the cradle to about 30 degrees, then release it. If the cradle does not move, the load is balanced vertically. If it does, remove the payload, loosen the cradle bolts, raise or lower the cradle as needed, retighten the bolts, then remount the payload and check again.

Additional Guidance and Safety Notes

The X650 uses a heavy-duty tilt cradle designed to accommodate a wide range of professional camera configurations. Balancing is achieved by repositioning the payload—no fine-adjustment slots are present on the cradle.

Horizontal Balancing

- Ensure the head is powered off.
- Gently tilt the cradle until the payload is horizontal, then release it.
- If the cradle tilts, reposition the payload forward or backward using its mounting interface (e.g., dovetail plate or quick-release system).
- Repeat until the cradle remains level. Mark the balanced position.

Vertical Balancing

- Manually tilt the cradle to about 30°, then release it.
- If it swings back toward horizontal, the payload is too low and must be raised.
- If it continues tilting away, it is too high and must be lowered.
- Remove the payload and loosen the cradle mounting bolts.
- Adjust the cradle height using alternate mounting holes, risers, or shims.
- Retighten all fasteners and retest.
- Mark the final cradle mount position if needed.

IMPORTANT: An overweight or improperly balanced payload can cause permanent damage to the head.

WARNING: The X650 tilt cradle is heavier than standard models. Always support the cradle during adjustment and disconnect power before working on the head.

Configuring X300, X350, and X650 Heads

This section describes how to configure X300, X350, and X650 heads. Each head must be configured before it can be used.

Each X300, X350, and X650 head provides a web-based remote configuration interface (web interface) you can access over the IP network, using a web browser. The web interface enables you to configure network (IP) settings, set axis limits, view status and logging information, configure position tracking data output, perform firmware upgrades, and create and restore data backups.

Additionally, the X350 and X650 head features a local configuration touchscreen interface that enables you configure network (IP) settings, set axis limits, and operate (move) axes.

If you installed multiple X300, X300, or X650 heads, they all have the same IP address by default. Each robotic head must be assigned a unique IP address before it can be configured or controlled.

This section includes the following topics:

- “Using DashBoard Walkabout to Assign Unique IP Addresses”
- “Configuring X300, X350 and X650 Heads Remotely”
- “Configuring and Operating X350 or X650 Heads Locally”
- “Adding Heads to a Control System”

Using DashBoard Walkabout to Assign Unique IP Addresses

If you installed multiple X300, X350, and X650 heads, they all have the same IP address by default. Each robotic head must be assigned a unique IP address before it can be controlled.

Note: If you are configuring X350 heads and you have already either turned DHCP **ON** or assigned each head a unique IP address, skip this section.

This section describes how to use DashBoard Walkabout to detect all robotic heads on the IP network, and to configure the netmask, gateway, and IP address of each head to make them accessible on the network.

DashBoard Walkabout can detect and list multiple devices that have identical IP addresses. After all heads have been assigned unique IP addresses, you do not need to use DashBoard Walkabout to modify their network settings. You can instead use each head’s remote web interface, or alternatively for X350 or X650, use the head’s local touchscreen interface.

Before you begin, you need a list of the heads and their serial numbers. The serial number appears on a label on the bottom of the head. See **Figure 3** on **page 13**.

To configure network connectivity for X300 heads, you need a computer running Ross Video DashBoard, connected to the same physical network segment as the heads.

DashBoard is available as a free download from the following location on the Ross Video website, under **Downloads > Software**:

www.rossvideo.com/products-services/management-systems/automated-production-control/dashboard

To configure network connectivity for an X300, X350, or X650 head:

1. In DashBoard, tap **File > Show Walkabout**. The **Walkabout** utility appears (see **Figure 18**).

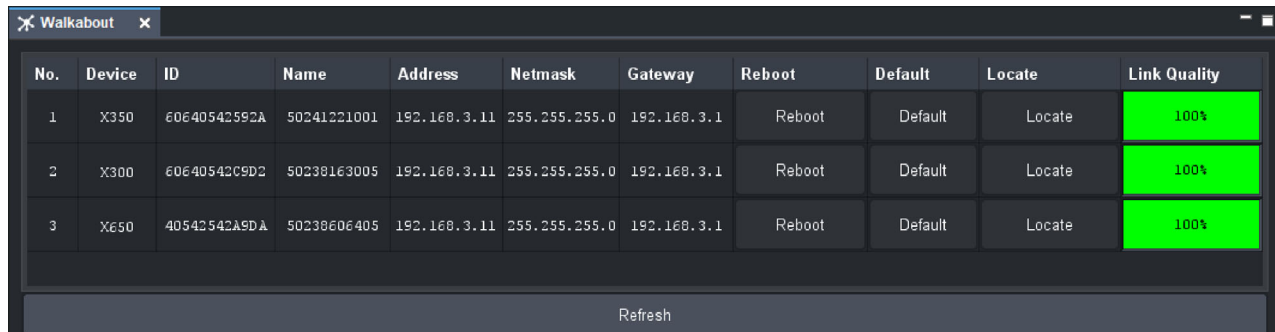

No.	Device	ID	Name	Address	Netmask	Gateway	Reboot	Default	Locate	Link Quality
1	X350	60E40542592A	50241221001	192.168.3.11	255.255.255.0	192.168.3.1	Reboot	Default	Locate	100%
2	X300	60E40542C9D2	50238163005	192.168.3.11	255.255.255.0	192.168.3.1	Reboot	Default	Locate	100%
3	X650	40542542A9DA	50238606405	192.168.3.11	255.255.255.0	192.168.3.1	Reboot	Default	Locate	100%

Figure 18 - DashBoard Walkabout Utility, showing Network Settings for X300, X350, X650 Heads

2. In Walkabout, tap the **Refresh** button. The list of network devices updates.
3. In the list, find the row in which the **Device** value lists the correct head type (**X300**, **X350**, or **X650**), and the **Name** cell value is the serial number of the head you want to configure.
You will edit cells in this row to configure the head.
If none of the **Name** cells display the head's serial number, the head is not connected to the network. Check power and network cables, and the network switch. For more information, see **"Troubleshooting"**.
4. In the **Address** cell, type a unique and valid IP address for the head.
Record the IP address. You will need it when you configure the control system to recognize the head.
5. In the **Netmask** cell, if a different netmask is required, type the correct netmask for your network.
6. In the **Gateway** cell, type the correct gateway for your network.
7. Tap **Refresh**, and then confirm that the IP **Address**, **Netmask**, and **Gateway** values are correct.
8. Tap **Reboot**.
The head reboots. Wait approximately 20 seconds, and then tap **Refresh**.
9. If you want to configure network settings for another head, go to **Step 3**.
10. Close DashBoard.

Configuring X300, X350 and X650 Heads Remotely

Each X300 or X350 head provides a web-based remote configuration interface (web interface), which you can access over the IP network using a web browser.

This section describes how to configure heads remotely, and includes the following topics:

- **"Accessing the Web Interface"**
- **"Configuring IP Settings (Network Settings)"**
- **"Setting Persistent Axis Limits"**
- **"Status and Logging"**
- **"Configuring Tracking Data Output"**
- **"Applying a Firmware Upgrade File"**
- **"Downloading and Restoring a Data Backup File"**
- **"Changing the On-Air or Preview Image for SmartTally"**

IMPORTANT: Do not modify any settings except as described in this section. Some other settings in the web interface may adversely affect performance or render the head inoperable.

Accessing the Web Interface

To access the web interface for an X300, X300, or X650 head, you need a computer connected to the same IP network as the head.

You also need to know the IP address of the head.

To obtain the IP address, if unknown:

- If the head has been added to DashBoard, hover over its **Slot** node in the DashBoard tree. The IP address appears, in brackets.
- If the head is an X350 or X650, tap its touchscreen. The IP address appears at the bottom of the screen.
- Use DashBoard Walkabout to detect the head and obtain its IP address.

Walkabout detects all Ross Video devices on the network, including X300, X350, and X650 heads. It shows the IP address (**Address** column), and serial number (**Name** column) of each head. For more information, see “**Using DashBoard Walkabout to Assign Unique IP Addresses**”.

To access the web interface:

- In a web browser, type the IP address of the head.

Tip: The default IP address is **192.168.3.11**.

The web interface appears (**Figure 19**).

The screenshot shows the web interface for an X350 head. At the top, there is a navigation menu with tabs: Status & Logging, Axis Settings, Log Settings, Tracking, IP Settings, Upgrade, Backup, and Tally. The 'Status & Logging' tab is selected. Below the navigation menu is a status bar with the text 'Status & Logging'. The main content area is divided into two sections. The first section is titled 'Information' and contains the following details: Device Type: X350, Serial Number: 50276776003, Firmware Version: 6.0.400.8140, and FPGA Version: 3.3. The second section is a table with the following columns: Status, Axis Name, Type, Motor Status, Encoder Status, Motor Position, and Encoder Position. The table contains four rows of data, all with a green checkmark in the Status column. Below the table is a section titled 'LOGFILES:' with a dropdown menu showing 'Furio.log' and two links: 'Download Furio.log' and 'Download Configuration Template'.

Status	Axis Name	Type	Motor Status	Encoder Status	Motor Position	Encoder Position
✓	ZOOM	LensAxis	Enabled	Integrated	0.000000	-
✓	FOCUS	LensAxis	Enabled	Integrated	0.000000	-
✓	PAN	FaulhaberCO	Enabled	Operational	-1.107267	-1.107267
✓	TILT	FaulhaberCO	Enabled	Operational	2.960053	2.960053

Figure 19 - Web Interface for X350 (Status & Logging Tab shown)

Configuring IP Settings (Network Settings)

You can use the web interface to view and modify the **IP Address**, **Netmask**, and **Gateway** settings for a head. You can also view the head's unique **MAC Address**.

If you modify IP settings, be sure to provide valid and appropriate values so the head is accessible to all devices that you want to control the head.

To view and/or modify IP settings:

1. On the **IP Settings** tab of the web interface, view the following settings and modify them as required:
 - **IP Address**
The factory default value is **192.168.3.11**.
 - **Netmask**
The factory default value is **255.255.255.0**.
 - **Gateway**
The factory default value is **192.168.3.1**.
2. View the **MAC Address** (read only).
3. If you modified any settings and want to apply them to the head, click the **Save and Reboot** button. The **Device is Rebooting** message appears (**Figure 20**).

IMPORTANT: Do not reload or refresh the web page during reboot. Doing so would cause the head to reboot again.

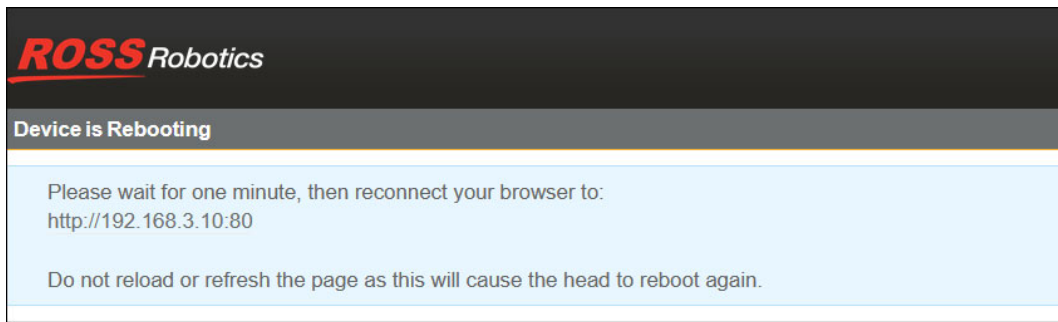

Figure 20 - Device is Rebooting Message

4. Wait for one minute, and then click the IP address link shown.
The web interface appears.

Setting Persistent Axis Limits

There are two types of axis limits; temporary limits and persistent limits:

- **Temporary limits** — These limits remain in force until they are changed or until the robotic head is restarted.

The range of motion defined by temporary limits is always within the range defined by persistent limits. Temporary limits are always either equal to, or more restrictive than, persistent limits.

These limits can be set by control systems such as DashBoard or SmartShell, and, if the head is an X350 or X650, they can also be set on the built-in touchscreen interface.

- **Persistent limits** — These limits remain in force until they are changed. They persist even if the robotic head is restarted or upgraded.

The range of motion defined by persistent limits is always the same or more permissive than temporary limits. By factory default, persistent limits define the full possible range of motion.

These limits can be set in the web interface, and, if the head is an X350 or X650, on the built-in touchscreen interface. Control systems cannot modify persistent limits, and cannot move an axis past its persistent limits.

This section describes how to use the web interface to set persistent limits.

Each axis has a minimum and maximum persistent limit. The limit values are set individually. To set a pair of limits (minimum and maximum) for an axis, you set one limit, move the axis manually, and then set the other limit.

Before you can manually move an axis and set its limits, the axis must be enabled:

- **For X300, X350 or X650** — An axis is enabled when the head is under the control of a control application such as SmartShell or DashBoard PT Head Control. You can use these applications, and/or joysticks connected to them, to manually move the axes.
- **For X350 or X650 only** — Alternatively, you can enable axes and manually move them using the built-in touchscreen interface. For more information, see “**Operating Axes Locally (X350 and X650 only)**”.

Note: Narrowing axis limits can adversely affect existing presets and moves. For example, if you create a preset and later set axis limits to be more restrictive, the preset destination may be outside of one or more axis limits. You may need to update existing presets after you adjust axis limits.

To set persistent axis limits:

1. In the web interface, on the **Axis Settings** tab, click the **Enable Edit** button.
A warning message appears, asking you to confirm that you want to proceed.
2. Click **Yes**.
3. Scroll down to the **Axis Properties** area.
The **Axis Properties** area includes status information and limit settings for each axis.
4. For the axis you want to configure, note the **Motor Position** value, if shown.
Tip: If no value is shown, repeat **Step 1** by selecting the address bar and pressing enter to reload `axissettings2.html`. The current **Motor Position** for the axis appears.
5. Move the axis manually slightly in one direction, and then refresh your browser:
 - If the **Motor Position** increased, you moved it towards the high limit.
 - If the **Motor Position** decreased, you moved it towards the low limit.
6. If you want to set the low limit:
 - a. In the **Active Low Limit** row, click **Clear**.
The view refreshes. The **Active Low Limit** for the axis is now at its lowest possible value.
 - b. Manually move the axis to the position you want to record as the low limit, and then click **Set Current**.
The view refreshes. The **Active Low Limit** value now matches the **Motor Position** value.
7. If you want to set the high limit:
 - a. In the **Active High Limit** row, click **Clear**.
The view refreshes. The **Active High Limit** for the axis is now at its highest possible value.
 - b. Move the axis to the position you want to record as the high limit, and then click **Set Current**.
The view refreshes. The **Active High Limit** value now matches the **Motor Position** value.
8. If you want to set persistent limits for another axis, go to **Step 4**.

Status and Logging

The web interface provides information about the head and the current status of each axis. It also enables you to view and download logs, and to set the level of detail the logs record.

This section includes the following topics:

- “**Enabling Logging and Setting Logging Detail Level**”
- “**Viewing Head Information and Axis Status**”
- “**Downloading and Saving Log Files**”

Enabling Logging and Setting Logging Detail Level

When logging is enabled, the head logs information about its activities.

These logs can be useful for diagnosing and troubleshooting problems.

Warning: When the **Logging Detail** level is set to record more information, log files roll over faster and cover a shorter period of time with greater detail. Head performance may be affected. Unless specifically instructed to do so by Ross Video Technical Support, we recommend that you do not change the **Logging Detail** level.

To enable or disable logging, and/or set the logging detail level:

1. In the web interface, on the **Log Settings** tab, either select or clear the **Enable Logging** check box, as required.
2. If you want to change the **Logging Detail** level, from the **Logging Detail** list, select the desired logging level.

Tip: Logging data is generated only if logging is enabled.

3. If you made any changes, click **Save**.

Viewing Head Information and Axis Status

You can view information about the head, including the **Device Type** (X300, X350, or X650), **Serial Number**, **Firmware Version**, and **FPGA** (computer hardware) version.

You can also view status information about each axis.

To view head information and axis status:

- In the web interface, click the **Status & Logging** tab.
Head information and axis status information appears (**Figure 21**).

Status	Axis Name	Type	Motor Status	Encoder Status	Motor Position	Encoder Position
✓	ZOOM	LensAxis	Enabled	Integrated	0.000000	-
✓	FOCUS	LensAxis	Enabled	Integrated	0.000000	-
✓	PAN	FaulhaberCO	Enabled	Operational	-1.107267	-1.107267
✓	TILT	FaulhaberCO	Enabled	Operational	2.960053	2.960053

Status & Logging

Information
Device Type: X350 Serial Number: 50276776003 Firmware Version: 6.0.400.8140 FPGA Version: 3.3

Figure 21 - Status & Logging Tab, showing Head Information and Axis Status Information

Downloading and Saving Log Files

When logging is enabled, the head logs information about its activities. These logs can be useful for diagnosing and troubleshooting problems.

This section describes how to download and save two types of log files — **Furio.log** and **Gui.log**.

Alternatively, you can save a data backup file, which contains all log files plus presets, moves and other data. If you encounter problems, Ross Video Technical Support personnel may ask you to create a data backup file and submit them it for analysis. For more information, see “**Downloading and Restoring a Data Backup File**”.

To download and save log files:

1. Click the **Status & Logging** tab of the web interface.
2. If you want to download and save a **Furio.log** file, do the following:
 - a. In the **LOGFILES** list, select **Furio.log**.
 - b. Click the **Download Furio.log** button.
The log data appears in a new web browser tab.
 - c. In your web browser, save the page as a text file with a **.log** file extension. For example, **Furio.log**.
Tip: The exact method of saving the page depends on which web browser you use. Alternatively, you can copy and paste the data into a text editor such as Windows **Notepad**, and save it as a text file with a **.log** file extension. For example, **Furio.log**.
3. If you want to download and save a **Gui.log** file, do the following:
 - a. In the **LOGFILES** list, select **Gui.log**.
 - b. Click the **Download Furio.log** button.
You are prompted to **Open** or **Save** the file.
 - c. Save the file.
The file is named **Gui.log**, and is saved to the Windows **Downloads** folder.

Configuring Tracking Data Output

The X350 and X650 heads generate and output axis position tracking data that can be used for AR/VS (Augmented Reality / Virtual Set) applications.

You can specify the tracking data protocol (FreeD or ORAD) and the output method(s) (UART and/or UDP).

IMPORTANT: You must use the X350 or X650 for AR, VS, or XR applications instead of the X300. Unlike the X300, the X350 or X650 can accept a sync signal.

To configure tracking data output:

1. In the web interface, click the **Tracking** tab.

The **Tracking Settings** appear (**Figure 22**).

Status & Logging | Axis Settings | Log Settings | **Tracking** | IP Settings | Upgrade | Backup | Tally

Tracking Settings

Information

Device Type: X350
Serial Number: 50276776003
Firmware Version: 6.0.400.8140
FPGA Version: 3.3

Protocol: **ORAD** ▾

Send via UART:

Send over UDP:

Send	IP	Port	Is Multicast	Multicast TTL
<input type="checkbox"/>	10.68.0.203	10244	<input type="checkbox"/>	1
<input type="checkbox"/>	192.168.0.203	10244	<input type="checkbox"/>	1
<input type="checkbox"/>	192.168.0.203	10244	<input type="checkbox"/>	1

Save and Reboot

Figure 22 - Tracking Tab, showing Tracking Data Output Settings

2. In the **Protocol** list, select the data protocol that the recipient application requires (**FreeD** or **ORAD**).
3. If you want to transmit the tracking data over the serial port, select the **UART** check box.
4. If you want to send the tracking data to specified destinations over UDP, do the following for up to three recipients (as represented by table rows in the interface):
 - a. Select the **Send** check box.
 - b. In the **IP** box, type the IP address of the destination device. Multicast addresses are supported.
 - c. In the **Port** box, type the port number through which the destination device will receive the tracking data.
 - d. If you do not want to use Multicast transmission, clear the **Is Multicast** check box.

Tip: The **Multicast TTL** value is ignored when the **Is Multicast** check box is not selected.
 - e. If you want to override the default TTL value assigned to multicast-addressed datagrams, select the **Is Multicast** check box, and then set the **Multicast TTL** value:
 - If you want to restrict traffic to the same subnet as the head, set the **Multicast TTL** value to **1**.
 - If your tracking destination is on a different subnet, set the **Multicast TTL** value to a value higher than **1**, according to your network configuration. Consult with your network administrator.

5. Click the **Save and Reboot** button.

The **Device is Rebooting** message appears (**Figure 23**).

IMPORTANT: Do not reload or refresh the web page during reboot. Doing so would cause the head to reboot again.

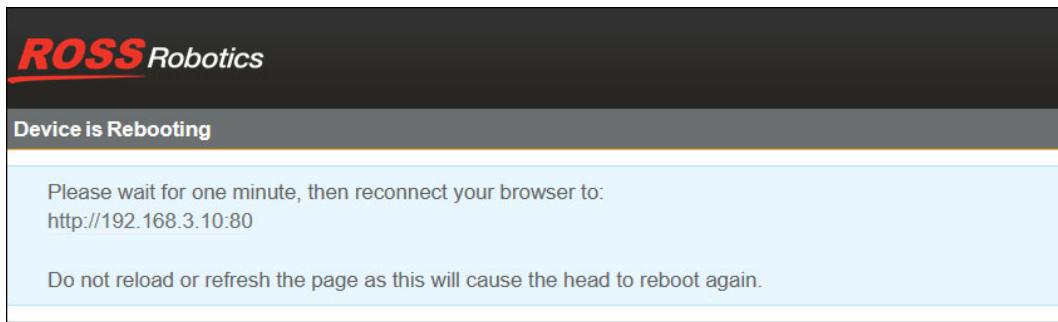

Figure 23 - Device is Rebooting Message

6. Wait for one minute, and then click the IP address link shown.

The web interface appears.

Applying a Firmware Upgrade File

You can use the web interface to apply a firmware upgrade file to an X300, X350, or X650 head.

IMPORTANT: Applying a firmware upgrade file is only one step of the upgrade process. Depending on the nature of the upgrade and how your system is customized and configured, additional steps may be required before and/or after applying the file. Consult with Ross Video Technical Support to determine the correct upgrade process for your situation.

IMPORTANT: Do not apply a firmware upgrade file unless instructed to do so by Ross Video Technical Support.

IMPORTANT: Upgrading firmware erases all temporary axis limits and customizations stored on the head. Persistent axis limits are retained. You can save a data backup file, and then apply it to the head after the firmware upgrade is complete. For more information, see “**Downloading and Restoring a Data Backup File**”.

To apply a firmware upgrade file to an X300, X350 or X650 head:

1. Create an up-to-date backup of your custom configuration.
2. On the **Upgrade** tab of the web interface, click **Choose File**.

The **Open** dialog box appears.

3. Navigate to the firmware zip file, and then click **Open**.

Tip: The filename resembles the following example: **Furio-phy-5.2.400.7674.zip**.

The **Open** dialog box closes, and the filename appears beside the **Choose File** button.

4. Click the **Upload File and Reboot** button.

The **Device is Rebooting** message appears (**Figure 24**).

IMPORTANT: Do not reload or refresh the web page. Doing so would cause the head to reboot again.

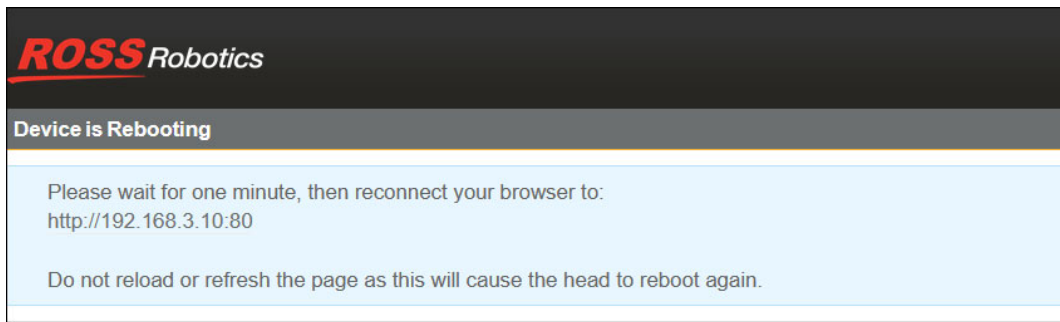

Figure 24 - Device is Rebooting Message

5. Wait for one minute, and then click the IP address link shown.

The web interface appears. The **Information** area shows the current **Firmware Version**. If the head is an X350 or X650, the touchscreen display shows the current firmware version.

Downloading and Restoring a Data Backup File

You can use the web interface to save (download) a backup copy of user data stored on an X300, X350, or X650 head, including presets, moves, temporary axis limits, and customizations. You can later apply (restore) the saved backup file to the same head or a different one.

This section describes how to download a data backup file, and how to restore it.

IMPORTANT: Downloading and restoring a data backup file are often steps within the process of upgrading a robotic head. Depending on the nature of the upgrade and how your system is customized and configured, some files within the data backup may need special modifications before you restore them. Consult with Ross Video Technical Support to determine the correct upgrade process for your situation.

To download a data backup file:

1. On the **Backup** tab of the web interface, click the **Download Data Backup** button.

The dialog box appears, prompting you to save or open the **backup.zip** file.

2. Select the option to save the file.

The file is saved to the **Downloads** folder on your computer.

Tip: Rename the file to give it a more meaningful name.

To restore a previously-downloaded data backup file:

1. On the **Backup** tab of the web interface, click the **Browse** button.

The **File Upload** dialog box appears.

2. Navigate to the downloaded data backup file, and then click **Open**.

Tip: By default, the file is in the **Downloads** directory, and is named **backup.zip**.

The **File Upload** dialog box closes, and the filename appears beside the **Browse** button.

3. Click the **Restore Data Backup** button.

The **Device is Rebooting** message appears (**Figure 25**).

IMPORTANT: Do not reload or refresh the web page during reboot. Doing so would cause the head to reboot again.

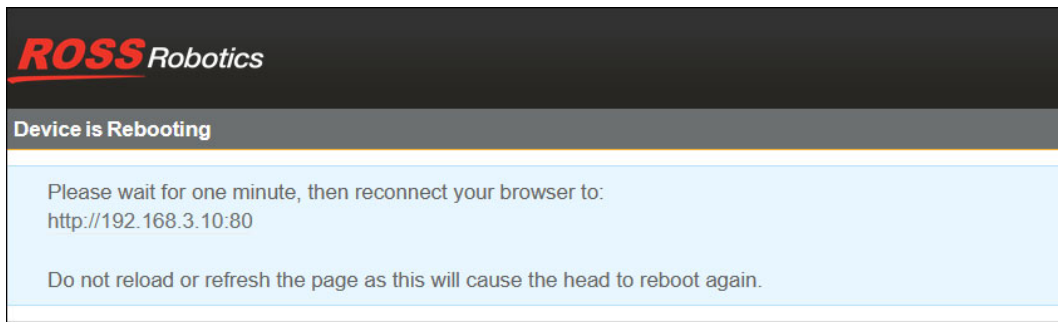

Figure 25 - Device is Rebooting Message

4. Wait for one minute, and then click the IP address link shown.
The web interface appears.

Rebooting the Head

You can reboot (restart) the head from the web interface.

To reboot the head:

1. In the web interface, on the **Status & Logging** tab, scroll to the bottom of the page and click the **Reboot** button.

The **Device is Rebooting** message appears (**Figure 26**).

IMPORTANT: Do not reload or refresh the web page during reboot. Doing so would cause the head to reboot again.

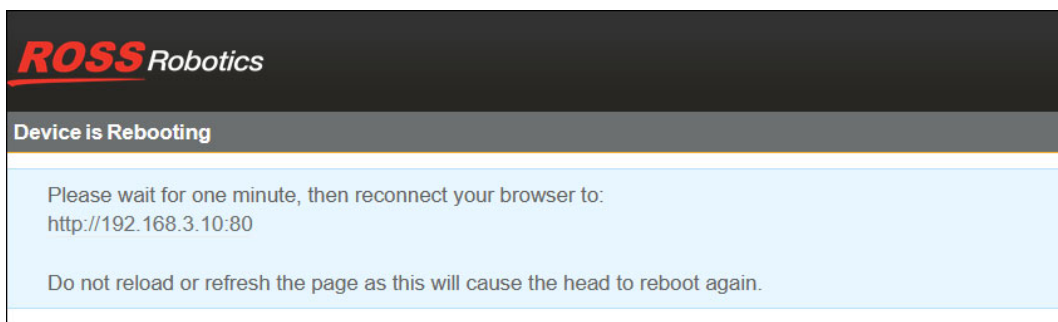

Figure 26 - Device is Rebooting Message

2. Wait for one minute, and then click the IP address link shown.
The web interface appears.

Changing the On-Air or Preview Image for SmartTally

You can modify the **OnAir** and **Preview** SmartTally image that displays on the X350 or X650 touchscreen from the **Tally** tab in the web interface (on the X350 or X650 only).

To upload a new touchscreen Tally image:

1. In the web interface, on the **Tally** tab, select the **Image Type** as either **OnAir** or **Preview** from the dropdown menu.
2. Select the **Choose File** button to upload a PNG file (**Figure 27**).
IMPORTANT: The X350 and X650 system only accept PNG images that are 480 x 818 px (96 DPI).
3. Select **Load Image**.

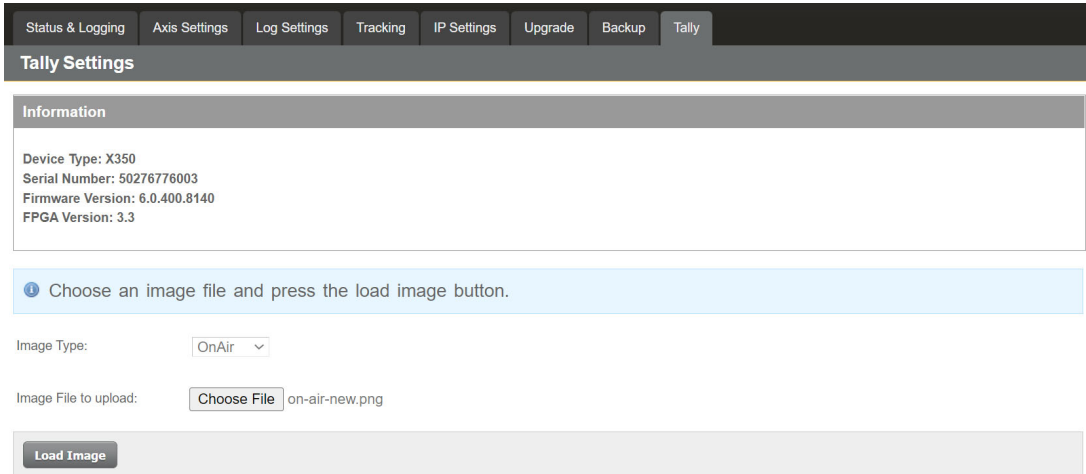

The screenshot shows the 'Tally Settings' page in a web interface. At the top, there is a navigation bar with tabs for 'Status & Logging', 'Axis Settings', 'Log Settings', 'Tracking', 'IP Settings', 'Upgrade', 'Backup', and 'Tally'. Below this is a 'Tally Settings' header. The main content area is titled 'Information' and displays device details: 'Device Type: X350', 'Serial Number: 50276776003', 'Firmware Version: 6.0.400.8140', and 'FPGA Version: 3.3'. Below the information is a light blue instruction box: 'Choose an image file and press the load image button.' Underneath, there is a form with 'Image Type:' set to 'OnAir' and a dropdown arrow. Below that, 'Image File to upload:' is shown with a 'Choose File' button and the filename 'on-air-new.png'. At the bottom of the form is a 'Load Image' button.

Figure 27 - Uploading new .png file in the Tally tab

Note: Once the default **OnAir** and **Preview** images (**Figure 28**) are overwritten, they can only be recovered by uploading an extracted copy of `./vrone/vrone_gui/resources/images/onair.png` or `./vrone/vrone_gui/resources/images/preview.png` from the `Furio-phy-x.x.xxx.xxxx.zip` file.



Figure 28 - Default OnAir and Preview images for the X350

Configuring and Operating X350 or X650 Heads Locally

The X350 and X650 heads feature a built-in touchscreen interface that enables you to configure network settings, set axis limits, and operate (move) axes locally.

If you want to perform other X350 or X650 configuration tasks, you must use the remote web interface. For more information, see “**Configuring X300, X350 and X650 Heads Remotely**”.

This section includes the following topics:

- “**Configuring Network Settings Locally (X350 and X650 only)**”
- “**Operating Axes Locally (X350 and X650 only)**”
- “**Setting Axis Limits Locally (X350 and X650 only)**”

To access the X350 or X650 configuration interface:

1. If the screen is black, tap the screen.

The main menu of the interface appears (**Figure 29**).

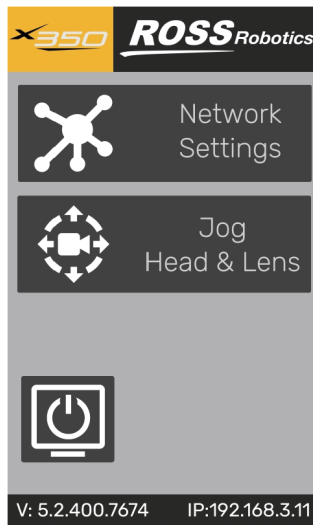

Figure 29 - Main Menu of the X350 or X650 Configuration Interface

2. On the X350 only, if the display is upside-down:
 - a. Rotate the Ross logo badge on the side of the head (**Figure 30**).

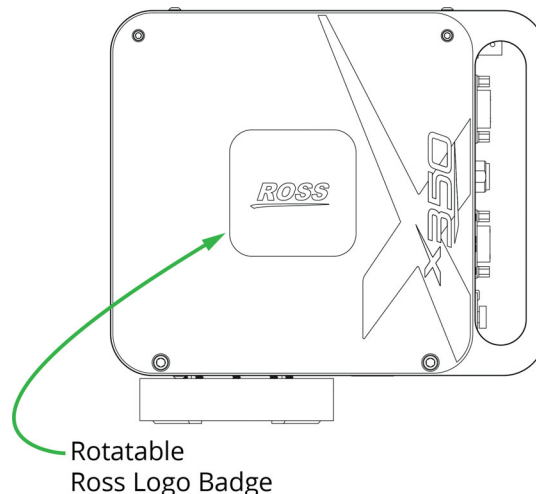

Figure 30 - X350 Head, showing Rotatable Ross Logo Badge

- b. Disconnect power from the head.
 - c. Wait at least 20 seconds.
 - d. Reconnect power to the head.
- The interface appears.

Configuring Network Settings Locally (X350 and X650 only)

Each robotic head must have a unique IP address.

You can configure a static IP address, or configure the head to use an IP address assigned by a DHCP server on your network.

To configure network settings locally, you must first check the **DHCP** setting (**On / Off**) and modify it if necessary, and then configure static network settings if you are not using DHCP.

To check and modify the DHCP setting:

1. On the touchscreen, tap the **Network Settings** button (Figure 32).

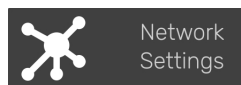

Figure 31 - Network Settings Button

The network settings appear (Figure 32).

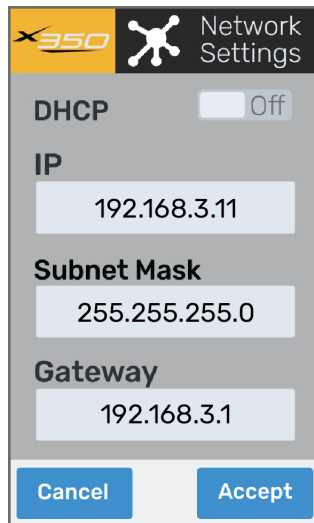

Figure 32 - X350 Network Settings

The **DHCP** button shows whether DHCP is enabled (**On**) or disabled (**Off**) (Figure 33).



Figure 33 - DHCP Button displays the Current State: **Off** (left), and **On** (right)

2. If **DHCP** is set to the desired option, skip the remaining steps in this procedure.
3. Tap the **DHCP** button to change it to the desired option, and then tap **Accept**.
A **Warning** message appears, to inform you that the head will reboot.
4. Click **Accept**.
The head reboots, and then the main menu appears.

To configure static network settings:

1. On the touchscreen, tap the **Network Settings** button (**Figure 34**).

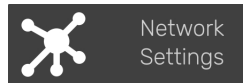

Figure 34 - Network Settings Button

The network settings appear (**Figure 35**).

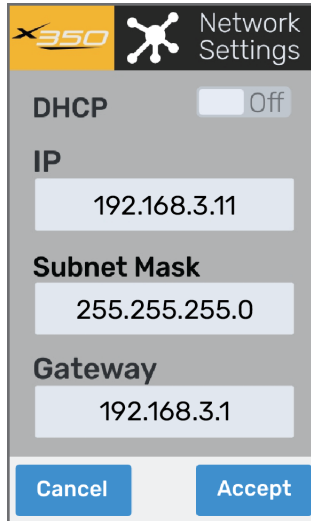

Figure 35 - X350 Network Settings

2. Tap the **IP** box, and then type a unique IP address for the head (**Figure 36**).
Tip: Make a note of the IP address. You'll need it when you add the head to your control system.

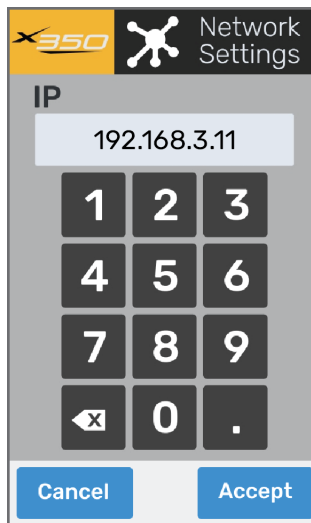

Figure 36 - Editing the IP Address

3. Tap **Accept**.
4. Tap the **Subnet Mask** box, and then type the correct netmask for your network.
5. Tap **Accept**.
6. Tap the **Gateway** box, and then type the correct gateway for your network.
7. Tap **Accept**.

- Review the network settings to ensure they are correct, and then tap **Accept**.
A **Warning** message appears, to inform you that the head will reboot (**Figure 37**).

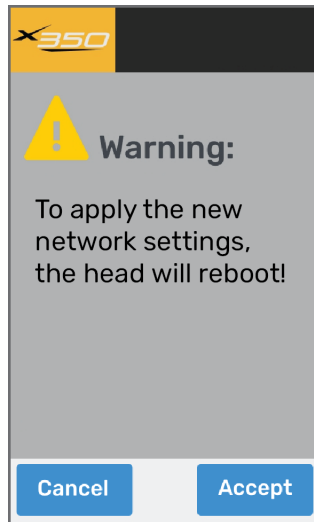

Figure 37 - Warning Message (Head Will Reboot)

- Click **Accept**.

The head reboots, and then the touchscreen display returns.

Operating Axes Locally (X350 and X650 only)

You can use the touchscreen interface to operate (move) each axis manually.

Controls for the various axes are presented on two main tabs:

- Head tab** — Includes sub-tabs for the **Pan** and **Tilt** axes (**Figure 38**).

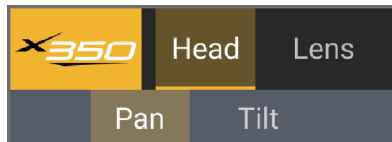

Figure 38 - The Head Tab, with the Pan Axis Tab Selected

- Lens tab** — Includes sub-tabs for the **Focus**, **Zoom**, and **Iris** axes.

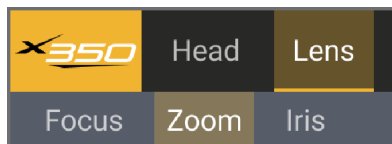

Figure 39 - The Lens Tab, with the Zoom Axis Tab Selected

Tip: The currently-selected tabs are shaded yellow.

IMPORTANT: When operating axes locally, especially if axis limits have not been set, watch the payload as it moves to ensure that it does not collide with anything, and that cables are not pulled tight. Adjust axis limits as required to avoid undesirable motion.

To operate an axis:

1. On the touchscreen, tap the **Jog Head & Lens** button (**Figure 40**).

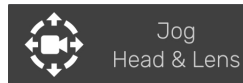

Figure 40 - Jog Head & Lens Button

Controls for the **Pan** axis appear (**Figure 41**).

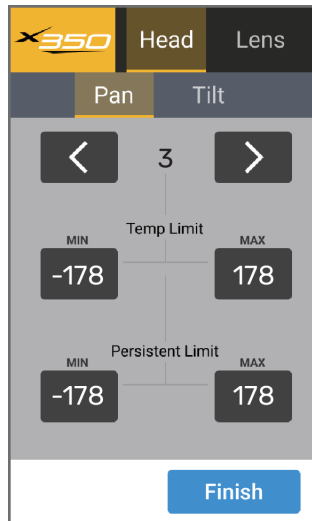

Figure 41 - Pan Axis Controls

2. Use the main tabs (**Head** and **Lens**) and their sub-tabs to navigate to the axis you want to operate. For example, **Lens > Zoom** (**Figure 42**).

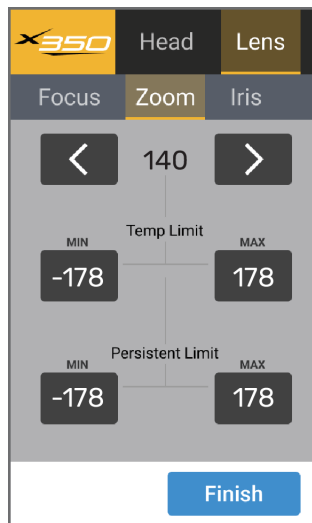

Figure 42 - Zoom Axis Controls

3. Press and hold an arrow button to move the axis (**Figure 43**).

Tip: Most sub-tabs have left and right arrow buttons. The **Tilt** axis has up and down arrow buttons.

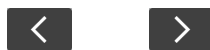

Figure 43 - Left and Right Arrow Buttons

4. If warning messages appear, indicating that the axis is not enabled and/or homed, tap **Accept** each time such a message appears (**Figure 44**).

Note: When the axis is homing, it moves. Several seconds may elapse before it stops and you can operate the axis.

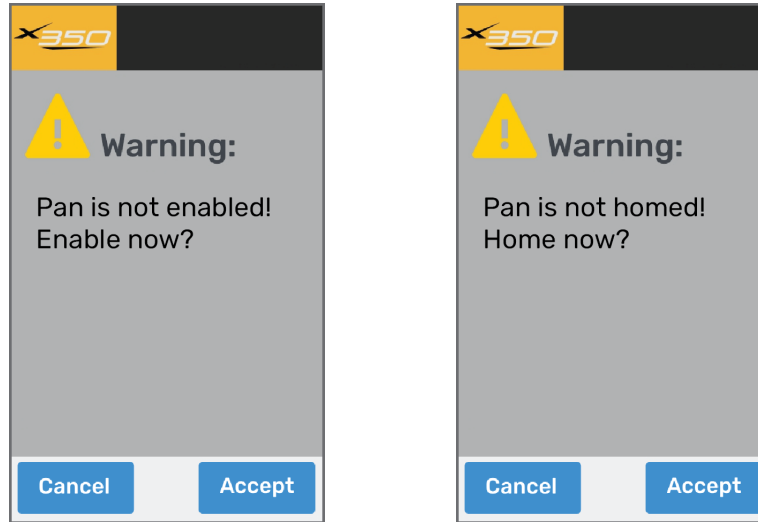

Figure 44 -Warning Messages (Pan is not enabled, and pan is not homed)

5. Press and hold the other arrow button to move the axis in the opposite direction.

Tip: If the axis stops moving and the arrow button is shaded yellow, the axis has reached a limit (**Figure 45**). The limit buttons for that end of the axis turn yellow. for information about using the touchscreen to set axis limits, see "**Setting Axis Limits Locally (X350 and X650 only)**".

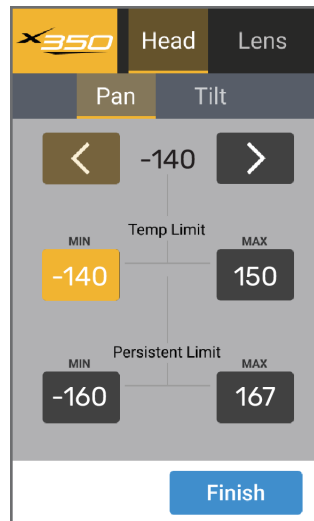

Figure 45 - The Pan Axis Reaches a Limit

6. If you want to operate a different axis, use the main tabs and sub-tabs to navigate to the controls for that axis, and then operate it.
7. When you are finished operating axes, tap **Finish** to return to the main menu.

Setting Axis Limits Locally (X350 and X650 only)

There are two types of axis limits; temporary limits and persistent limits:

- **Temporary limits** — These limits remain in force until they are changed or until the robotic head is restarted.

The range of motion defined by temporary limits is always within the range defined by persistent limits. Temporary limits are always either equal to, or more restrictive than, persistent limits.

These limits can be set by control systems such as DashBoard or SmartShell, and, if the head is an X350 or X650, they can also be set on the built-in touchscreen interface.

- **Persistent limits** — These limits remain in force until they are changed. They persist even if the robotic head is restarted or upgraded.

The range of motion defined by persistent limits is always the same or more permissive than temporary limits. By factory default, persistent limits define the full possible range of motion.

These limits can be set in the web interface, and, if the head is an X350 or X650, on the built-in touchscreen interface. Control systems cannot modify persistent limits, and cannot move an axis past its persistent limits.

Note: Narrowing axis limits can adversely affect existing presets and moves. For example, if you create a preset and later set axis limits to be more restrictive, the preset destination may be outside of one or more axis limits. You may need to update existing presets after you adjust axis limits.

The touchscreen controls for each axis consist of two movement arrows and two sets of limit buttons:

- **Movement arrows** — Press and hold an arrow to move the axis to the position you want to set as a limit (**Figure 46**).



Figure 46 - Left and Right Arrow Buttons

- **Temp Limit buttons** — The **MIN** button toggles to set or clear (erase) the minimum temporary limit. The **MAX** button toggles to set or clear the maximum temporary limit. See **Figure 47**.

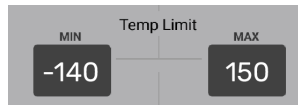

Figure 47 - Temp Limit Buttons

- **Persistent Limit buttons** — The **MIN** button toggles to set or clear the minimum persistent limit. The **MAX** button toggles to set or clear the maximum persistent limit. See **Figure 48**.

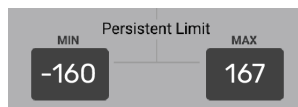

Figure 48 - Persistent Limit Buttons

You may need to clear existing limits to reach the position you want to set as a limit. When you encounter a limit, the arrow button and the limit button turn yellow (**Figure 49**).

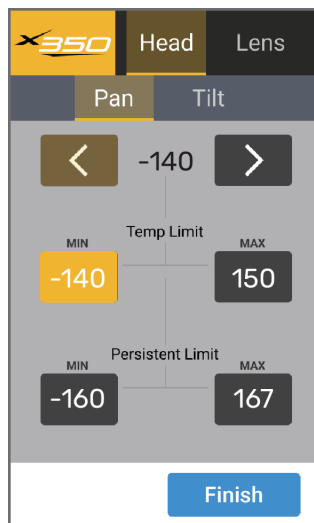

Figure 49 - The Pan Axis Reaches a Temporary Limit

Tips:

- When you set a persistent limit, the temporary limit for the same end of the axis is automatically set to the same value as the persistent limit.
- If you want to set both a persistent limit and a temporary limit for one end of an axis (**MIN** or **MAX**), you must set the persistent limit first. This is because temporary limits are always within persistent limits, so if you set the temporary limit first, you have to clear (erase) it in order to move the axis to the position you want to record as the persistent limit.

To set an axis limit:

1. Operate the axis for which you want to set a limit, moving it to the position you want to record as the limit. **Figure 50** shows controls for the **Pan** axis.

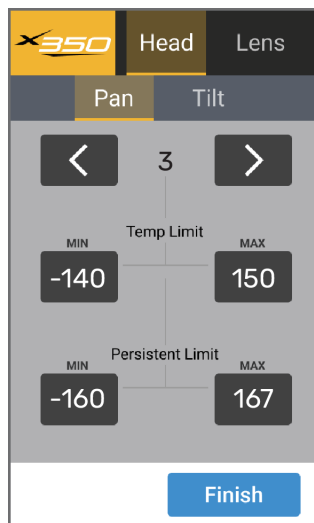

Figure 50 - Controls for the Pan Axis

2. As the axis moves, note whether the axis position value, displayed between the arrow buttons, increases or decreases:
 - If the value **decreases**, the axis is moving towards the minimum (**MIN**) end of the axis.
 - If the value **increases**, the axis is moving towards the maximum (**MAX**) end of the axis.

3. If the axis stops moving and the arrow button you pressed is shaded yellow, the axis has reached a temporary limit (**Figure 51**).

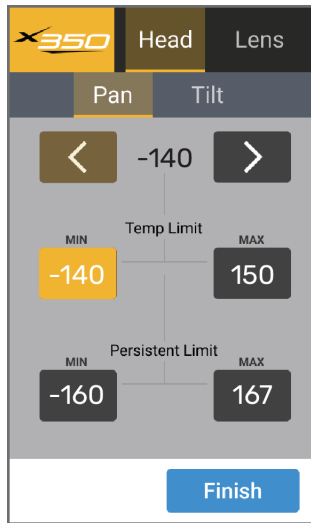

Figure 51 - The Pan Axis Reaches a Temporary Limit

Tap the yellow **Temp Limit** button to clear the temporary limit, and then continue moving the axis towards the position you want to record as the limit.

4. If the axis stops moving again and the arrow button you pressed is shaded yellow, the axis has reached a persistent limit.

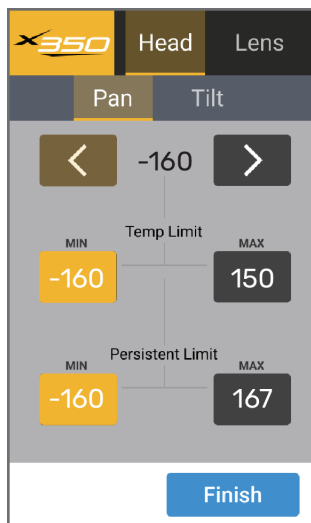

Figure 52 - The Pan Axis Reaches a Persistent Limit

Tap the yellow **Persistent Limit** button to clear the persistent limit. Continue moving the axis towards the position you want to record as the limit.

5. When the axis reaches the position you want to record as the limit do one of the following:
 - If you are satisfied with the current persistent limit and you want to set only a temporary limit, tap the **Temp Limit** button corresponding to the type of temporary limit you want to set at the current position (**MIN** or **MAX**).
 - If you want to set a persistent limit, tap the **Persistent Limit** button corresponding to the type of persistent limit you want to set at the current position (**MIN** or **MAX**).

A **WARNING** message may appear, informing you that setting the persistent limit will clear the temporary limit. Tap **Accept**.

The persistent limit is set, and the temporary limit is set to the same position.

6. If you want to set additional axis limits, repeat step **1** on page 3-48. Continue to step **5**.
7. When you are finished setting axis limits, tap **Finish** to return to the main menu.

Adding Heads to a Control System

After your heads are configured, they must be added (registered) to the control system (application or device) you want to use to operate them. A head can be added to multiple control systems, but only one can control it at a time.

The method of adding a head to a control system depends on the type of control system:

- **SmartShell control application** — Adding new robots is typically done by Ross Video Commissioners. For more information contact Ross Video Technical Support.
- **DashBoard PT Head Control plugin** — See see the *User Manual for PT Head Control Plugin (8351DR-019-xx)*. This manual is available at the following location, under **Downloads > Manuals**:
<https://www.rossvideo.com/products-services/acquisition-production/robotic-camera-systems/studio-robotics/>
- **Other control systems** — See the user documentation for the control application or device, or contact Ross Video Technical Support.

Controlling the X300, X350, and X650 Heads

The X300, X350, and X650 can be controlled through Ross Video DashBoard, Ross Video SmartShell, and the Furio API.

DashBoard Control (PT Head Control Plugin)

The PT Head Control plugin is a free DashBoard application that enables you to control the X300, X350, and other supported robotic Pan & Tilt heads (PT heads). The PT Head Control plugin is included as part of DashBoard.

Figure 53 shows the DashBoard PT Head Control plugin.

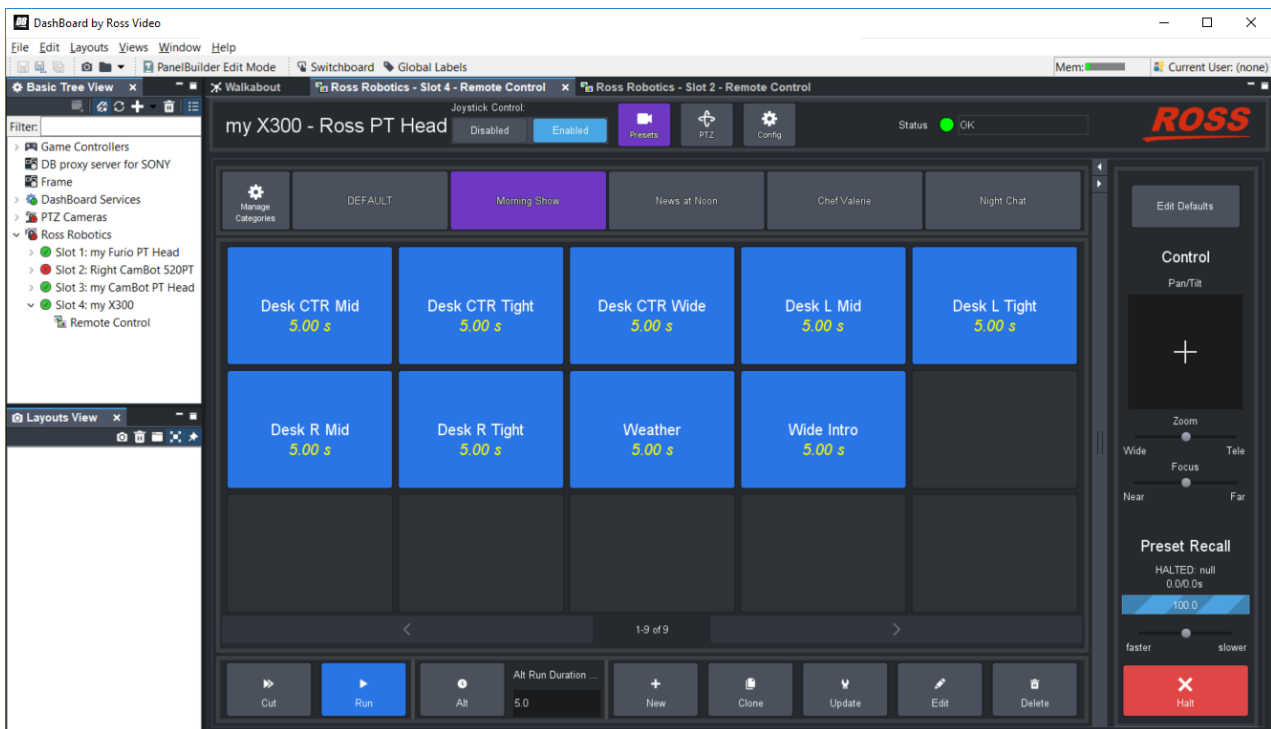

Figure 53 - DashBoard PT Head Control Plugin, showing controls for an X300 Head

Using DashBoard and the PT Head Control plugin, you can:

- control heads manually (pan and tilt axes)
- store and recall presets
- control lens functions (zoom, focus, iris)
- link to camera controls such as paint settings (selected cameras only). Linking to these controls enables you to control head and camera functions within a single user interface.
- add a USB joystick or other game controller to manually operate pan, tilt, zoom, focus, and iris axes. You can map buttons on the USB controller to perform camera selection and other tasks.

For detailed information about how to set up and use the DashBoard PT Head Control plugin, see the **User Manual for PT Head Control Plugin (8351DR-019-xx)**, available on the USB drive included with the X300 (5100USB-103-xx). The latest edition is available from the following location on the Ross Video website, under **Downloads > Manuals**.

www.rossvideo.com/products-services/acquisition-production/robotic-camera-systems/studio-robotics

SmartShell Control

SmartShell is a full-featured, enterprise level control system that can control X300 and X350 heads, as well as all other Ross Robotics devices, within a single user interface. SmartShell can also control selected third-party robots.

Some systems include multiple operator positions, each with its own SmartShell computer and SmartShell Joystick Panel.

For information about implementing a SmartShell control solution, contact Ross Video Technical Support.

Figure 54 on **page 52** shows the main SmartShell window, which enables you to configure axes and store and recall moves and presets.



Figure 54 - SmartShell Main Window, showing controls for a Furio Dolly

Figure 55 on page 53 shows SmartShell in Matrix mode, which enables you to efficiently run moves and presets on one or more robots during a show.

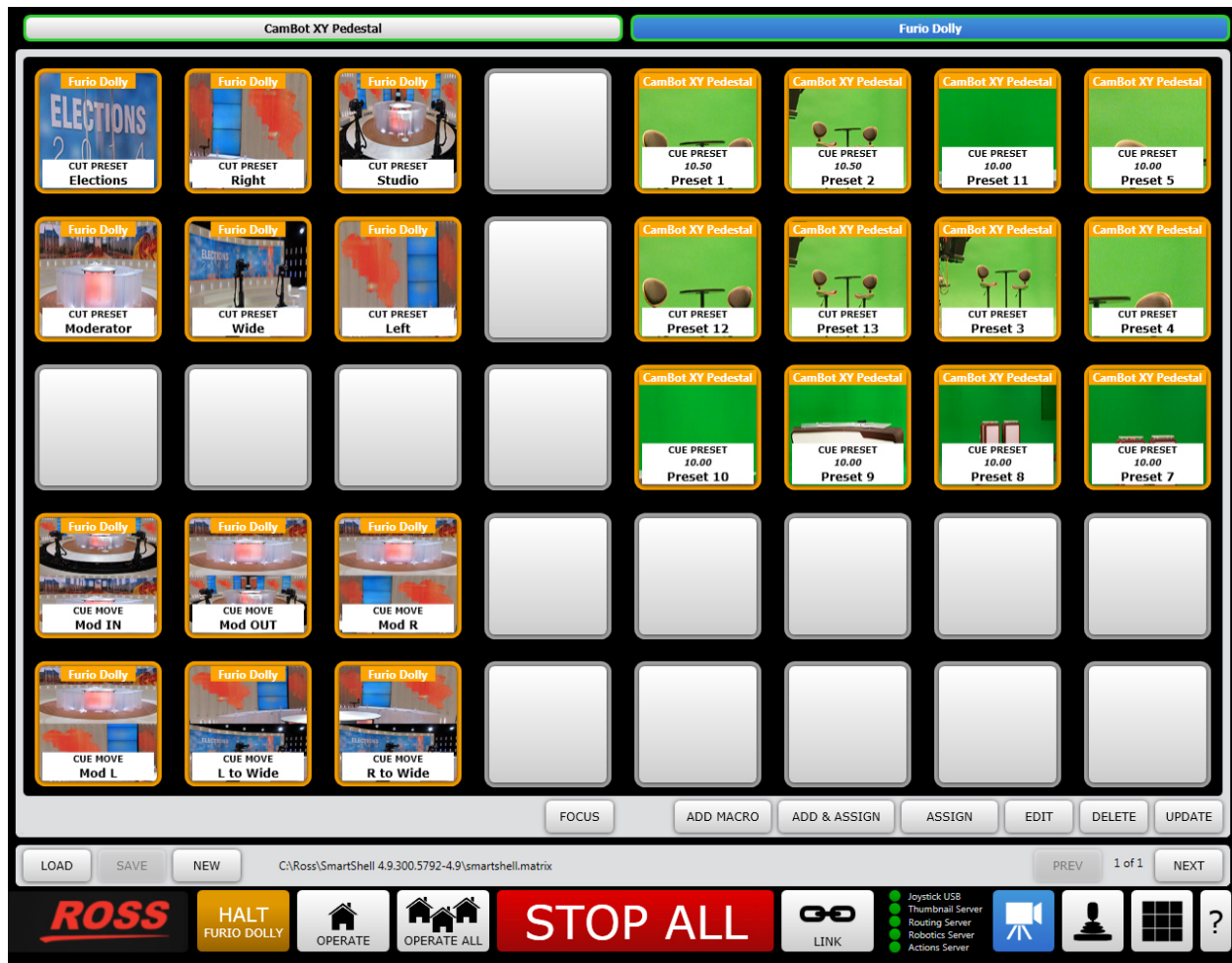

Figure 55 - SmartShell in Matrix Mode, showing Buttons Assigned to Recall Moves and Presets

Furio API Control

The X300, X350, and X650 heads use the Furio API, which facilitates direct control by Ross Production Switchers, OverDrive, and other third-party devices and controllers.

You can also use the Furio API to create custom control applications. For more information about implementing custom applications using the Furio API, contact Ross Video Technical Support.

Maintenance and Troubleshooting

This chapter describes how to maintain the X-Series Pan & Tilt Heads, and how to troubleshoot problems you may encounter. It includes the following topics:

- “Maintenance”
- “Troubleshooting”

Maintenance

Ross Video designed the X300, X350, and X650 heads to perform smoothly, accurately, and reliably for many years under full payload in demanding production environments.

These robotic heads do not require lubrication or internal maintenance. There are no user-serviceable parts inside other than the X650 drive belt, which can be serviced if authorized. Unauthorized disassembly of an X300, X350, and X650 may void product warranty.

To keep your robotic head running optimally, perform the following maintenance tasks periodically:

- Dust the unit, and/or wipe with a dry rag. Do not expose the head to water or any other liquids.
- Inspect the head and payload to ensure that:
 - › All cable connections are intact, and there is no strain on cables that run to the head.
 - › The payload is properly secured and has not shifted over time. Check the position of the camera cradle to ensure the screws are properly tightened and that it has not slipped.

IMPORTANT: If the payload has been modified or has shifted, ensure that it does not exceed the payload limit of 15 lbs (6.8 kg) for the X300 and X350, or 125 lbs (57 kg) for the X650, and that it is properly balanced around the tilt axis, both horizontally and vertically. For more information, see “Balancing the Payload”.

Troubleshooting

The section describes problems you may encounter and how to resolve them.

If you are unable to resolve the problem, contact Ross Video Technical Support for assistance. For more information, see “**Company Address and Contact Information**”.

Refer to **Table 1** for troubleshooting information

Table 1 - Troubleshooting

Symptom	Steps to Diagnose and Resolve
Head does not start	<p>If you disconnect power and then reconnect it too soon, the head may fail to start properly.</p> <p>To resolve this issue, disconnect power, wait 20 seconds, and then reconnect power. The head should start normally.</p>
Head does not move at all	<ul style="list-style-type: none"> • Check for green power LED beside power connector. If the power LED is not illuminated green, check that the power cable and power adapter are plugged in, and that the power supply circuit is live. • Check network cable connections, and network data connectivity. Beside each Ethernet port (RJ45 jack) on the head, there is a green LED which indicates network connectivity: <ul style="list-style-type: none"> • OFF — There is no network connection. • ON SOLID — Head is connected to the network. • ON FLASHING — Head is connected to the network, and data is currently being transmitted to and/or from the head. • Check that the network switch is operating properly. • Check for control connectivity by using the control computer to do one of the following: <ul style="list-style-type: none"> • If you are using DashBoard PT Head Control, find the head in the DashBoard tree. If the status dot is green, DashBoard can communicate with the head. • In a web browser, launch the head’s web interface by navigating to the head’s IP address. If the web interface launches, the computer has network connectivity with the head. • If you cannot connect to the web interface, or if you do not know the head’s IP address, use DashBoard Walkabout to view and configure network connectivity settings. For more information, see “Using DashBoard Walkabout to Assign Unique IP Addresses”. • Check for obstructions or tight cables that may impair head motion. Remove all obstructions, and dress cables properly. For more information, see “Cabling and Tethering”. • If the Ethernet connections for multiple heads are cascaded (daisy-chained) from head-to-head, ensure that all heads in the chain are powered. Each head has a 1x2 Ethernet switch that must be powered to operate. • If the head is a model X350 and it is configured to use DHCP, check the IP address in the bottom right corner of the touchscreen. If there is no IP address shown, the DHCP server failed to assign an IP address.
Head moves jerkily, or stops responding to commands, or tilts freely	<ul style="list-style-type: none"> • If the payload has been modified or components of the payload may have shifted, it may be overweight and/or out of balance. Check that all payload components are properly secured to each other, and to the camera cradle. Check that the camera cradle is properly secured to the head. If you suspect that the payload may have shifted, rebalance the payload. Ensure that it does not exceed the payload limit of 15 lbs (6.8 kg), and that it is properly balanced around the tilt axis, both horizontally and vertically. For more information, see “Balancing the Payload”. • If the head has been abused by overloading or by operating with an imbalanced payload, an internal drive belt may be damaged. If you suspect this may be the case, contact Ross Video Technical Support for assistance.

Technical Specifications

This chapter contains drawings and technical specifications for X-Series Pan & Tilt Heads. It also describes mounting accessories that are available from Ross Video.

This chapter includes the following sections:

- “**Technical Specifications**”
- “**Drawings of the X300 Pan & Tilt Head**”
- “**Drawings of the X350 Pan & Tilt Head**”
- “**Connector Pin Assignments**”
- “**Optional Mounting Accessories**”

Technical Specifications

Table 2 contains technical specifications for the X300, X350, and X650 Pant Tilt Heads.

Table 2 - Technical Specifications

Feature / Property	X300	X350	X650
Product name and ordering code	Ross Video X300 Robotic Pan & Tilt Head Ordering code RRB-X300-PT	Ross Video X350 Robotic Pan & Tilt Head Ordering code RRB-X350-PT	Ross Video X650 Robotic Pan & Tilt Head Ordering code RRB-X650-PT
Physical dimensions	Approximately 5 7/8" W x 7 3/8" H x 7 3/4" D (150 mm W x 190 mm H x 135 mm D)		Approximately 17" x 111" x 7" (432 mm x 279 mm x 178 mm).
Maximum payload	15 lbs (6.8 kg)		125 lbs (57 kg)
Pan axis range	±178° (356° total)		
Tilt axis range	±78° (356° total)		+/- 90°
Pan and tilt speed range	0.1° to 45° per second		0.1° to 90° per second
Maximum pan and tilt acceleration rate	60°/sec ²		
Positional accuracy and repeatability	±0.5°		<0.02°
Drive train gear type	Anti-backlash gears in the drive train ensure smooth motion suitable for on-air shots		
Digital lens control	Digital control of a wide variety of Canon and Fujinon full servo serial lenses (zoom, focus, iris).		
Analog lens control	Zoom, Focus, and Iris		
Serial digital camera control	N/A	Serial digital camera control over RS232 and RS422	
Remote configuration interface	Web-based configuration interface. Default IP address is 192.168.3.11.		

Table 2 - Technical Specifications

Feature / Property	X300	X350	X650
Local configuration interface	N/A	Built-in 5" touchscreen interface	Built-in 5" touchscreen interface
Control interface (user interface)	Fully controllable through any and all of the following: <ul style="list-style-type: none"> • The PT Head Control Plugin, a free control application included with Ross Video DashBoard. The plugin enables you to create and recall presets, and use a third-party USB joystick or other game controller. • Ross SmartShell, a full-featured enterprise-level control system that can control all Ross Robotics devices within a single user interface. Includes joystick panel with camera selection buttons. • The Furio API, which enables direct control by Ross Production Switchers, OverDrive, and other third-party devices and controllers. 		
Axis encoders and position tracking data for AR/VS	The X300 has axis encoders, but the X350 is recommended for AR/VS applications instead of the X300, because unlike the X300, the X350 can accept a sync signal.	FreeD and ORAD tracking data output via UART and/or UDP (up to three destinations)	
Video SYNC IN/OUT	N/A	Yes (Standard BNC connectors)	
Compatible with Furio Dolly, SkyDolly, and BlackBird Pedestal	N/A	Yes (control through CAN bus)	
Approximate net weight	11 lbs (5.0 kg)		21 lbs (9.1 kg)
Power input and power adapter specifications	See " Power and Networking Requirements "		
Storage temperature, operating temperature, and operating humidity	See " General Studio Requirements "		

Note: The maximum prompter size supported by the X650 is 19" for X650.

Drawings of the X300 Pan & Tilt Head

This section contains the following drawings:

- "**Back (connection panel)**"
- "**Front**"
- "**Right Side (camera cradle side)**"
- "**Left Side**"
- "**Bottom**"
- "**Top**"
- "**Angled Views (X300 head, mounted on a PM8 pedestal riser)**"

Note: Drawings are not to scale. All dimensions are in inches and millimeters [mm].

Back (connection panel)

Figure 56 shows the back of the X300 head, including the connection panel.

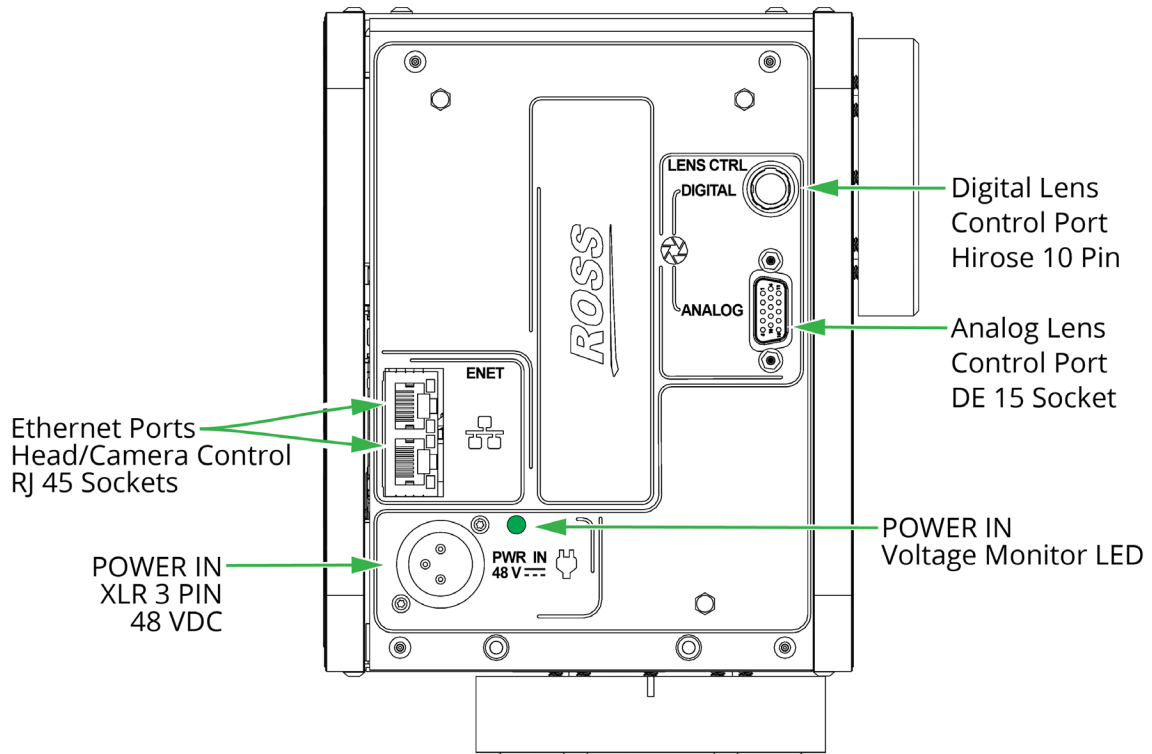

Figure 56 - X300 Pan & Tilt Head (back view, showing connection panel)

Front

Figure 57 shows the front of the X300 Pan & Tilt Head.

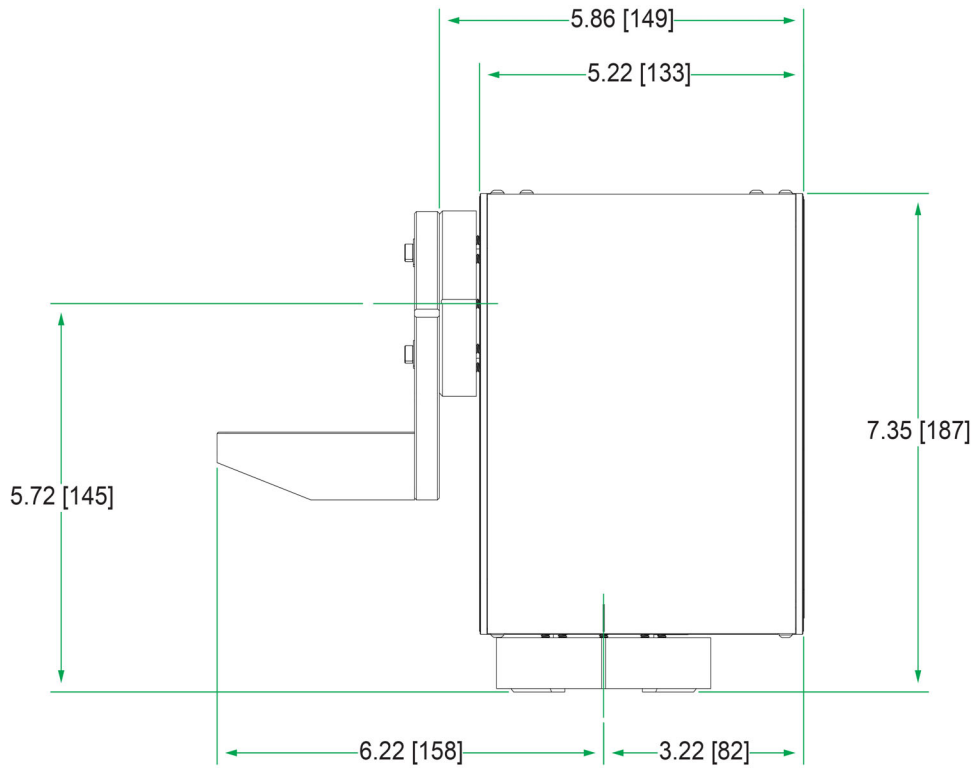

Figure 57 - X300 Pan & Tilt Head (front view)

Right Side (camera cradle side)

Figure 58 shows the right side of the X300 head.

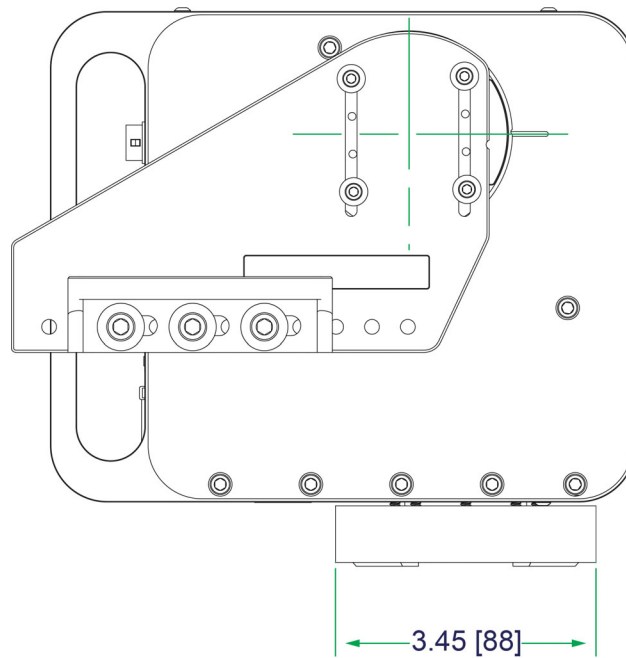

Figure 58 - X300 Pan & Tilt Head (right side)

Left Side

Figure 59 shows the left side of the X300 head.

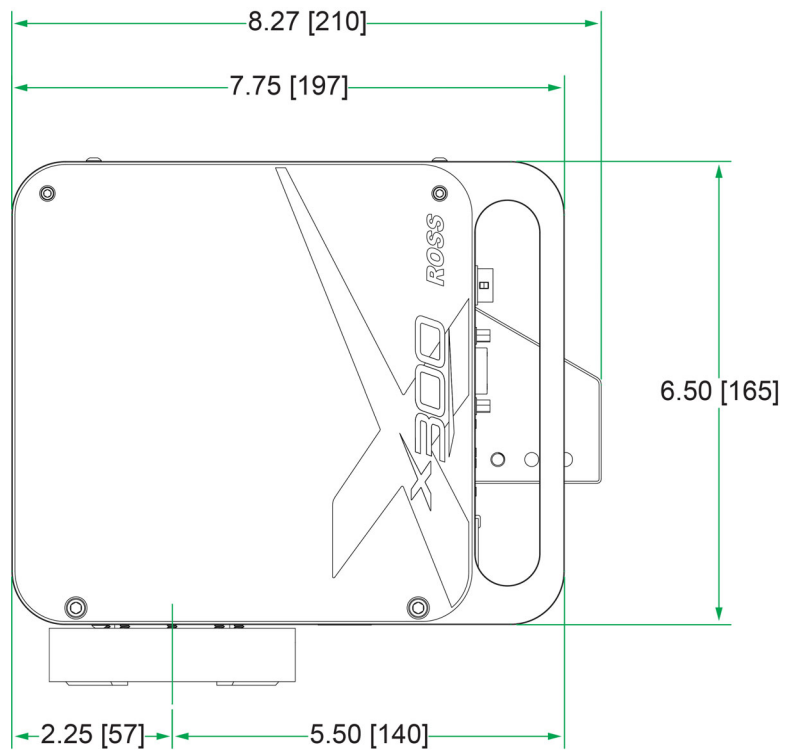

Figure 59 - X300 Pan & Tilt Head (left side)

Bottom

Figure 60 shows the bottom of the X300 head, without the camera cradle. For a drawing that shows mount hole spacing, see **Figure 3**.

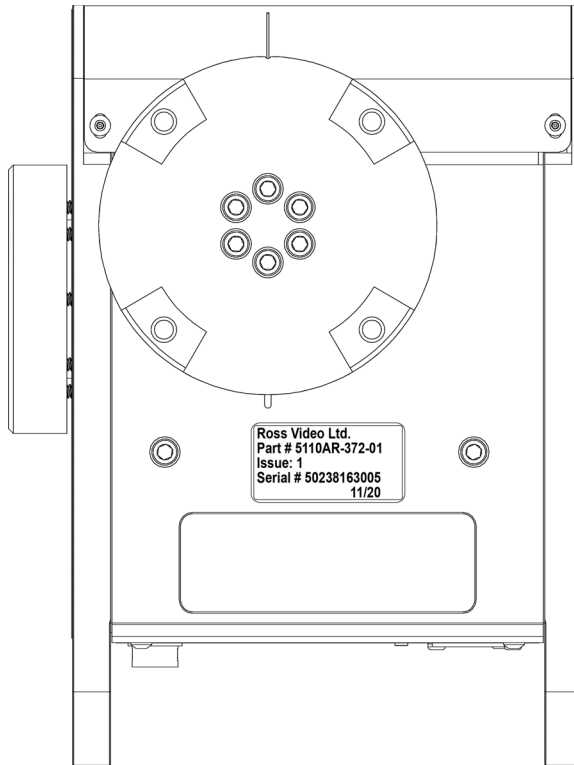

Figure 60 - X300 Pan & Tilt Head (bottom view, camera cradle not shown)

Top

Figure 61 shows the top of the X300 head.

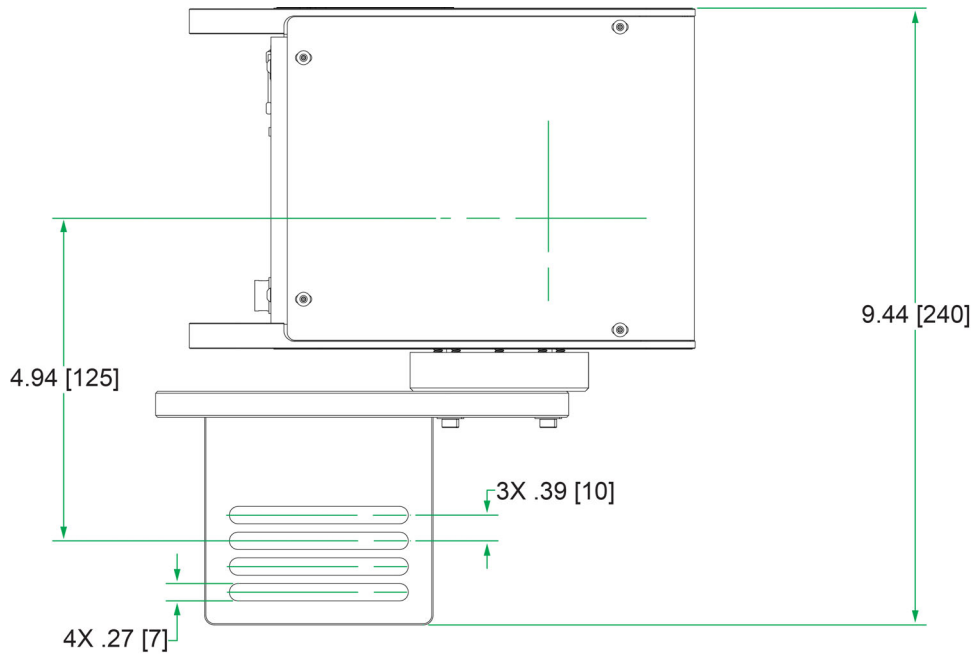

Figure 61 - X300 Pan & Tilt Head (top view)

Angled Views (X300 head, mounted on a PM8 pedestal riser)

Figure 56 shows the front of the X300 head, mounted on a PM8 Pedestal Riser.

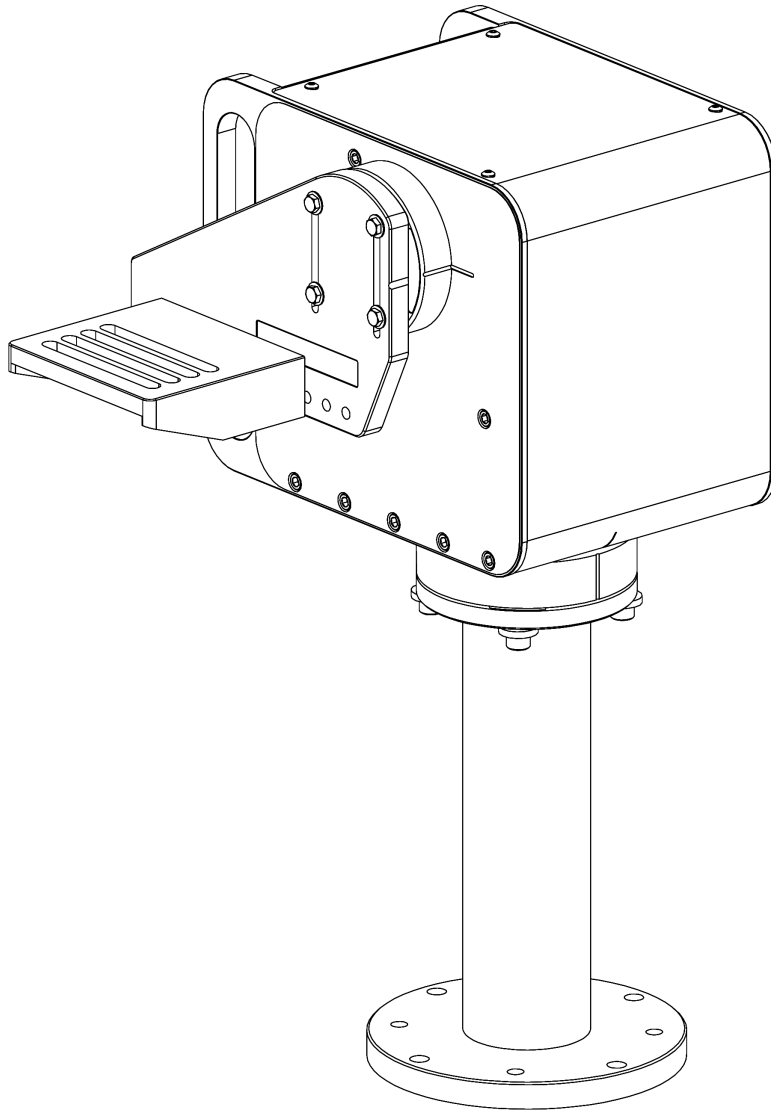

Figure 62 - X300 Pan & Tilt Head, Mounted on a PM8 Pedestal Riser (front angled view)

Figure 56 shows the back of the X300 head, mounted on a PM8 Pedestal Riser.

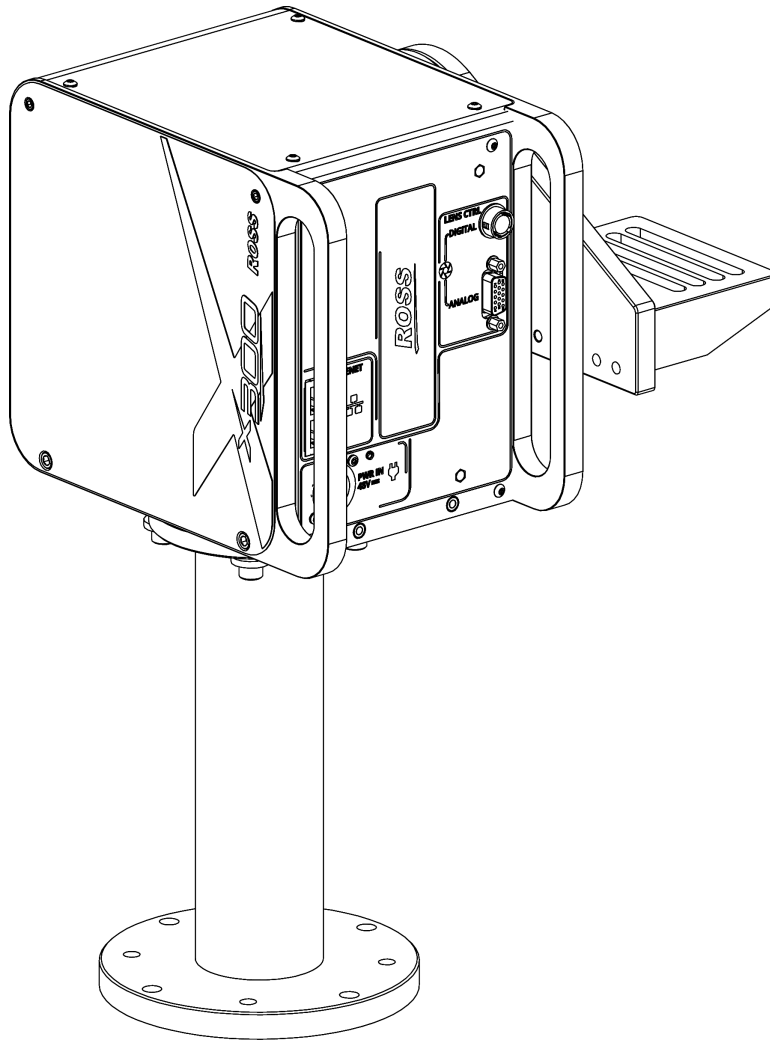

Figure 63 - X300 Pan & Tilt Head, Mounted on a PM8 Pedestal Riser (back angled view)

Drawings of the X350 Pan & Tilt Head

This section contains the following drawings:

- **“Back (connection panel)”**
- **“Front”**
- **“Right Side (camera cradle side)”**
- **“Left Side”**
- **“Bottom”**
- **“Top”**
- **“Angled Views (X350 head mounted on a PM8 pedestal riser)”**

Note: Drawings are not to scale. All dimensions are in inches and millimeters [mm].

Back (connection panel)

Figure 56 shows the back of the X350 head, including the connection panel.

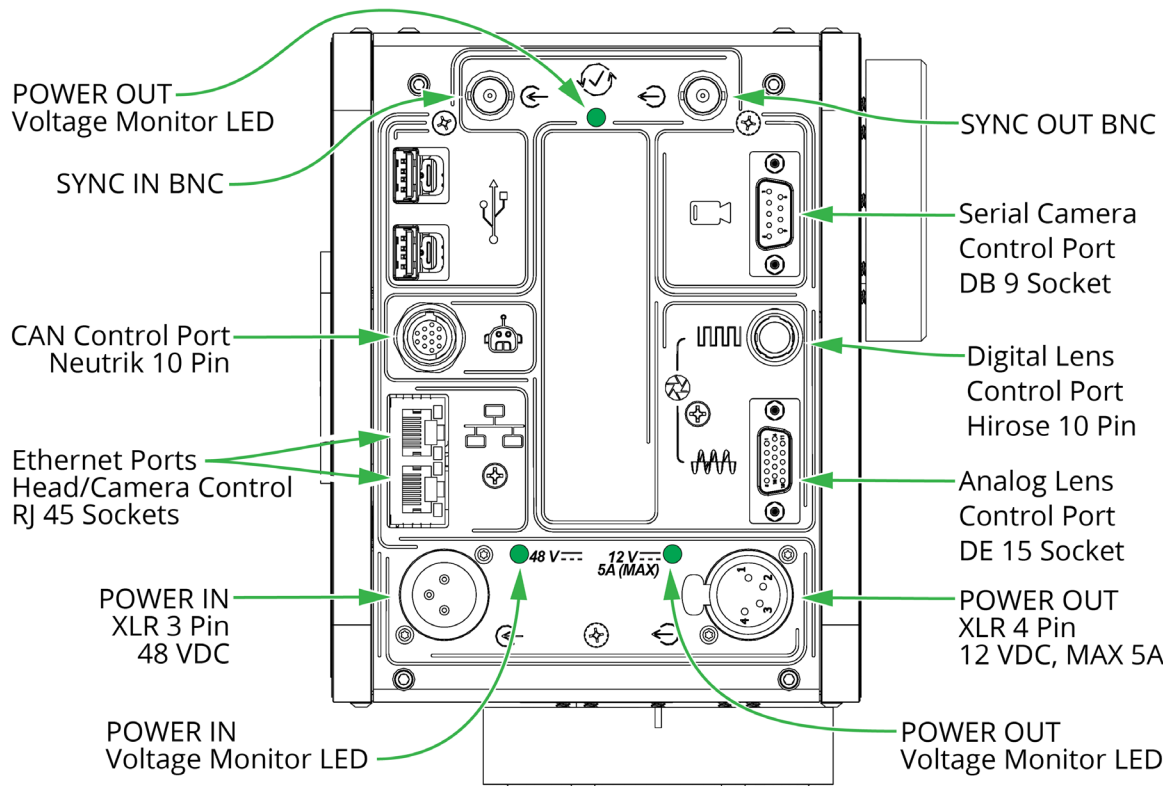

Figure 64 - X350 Pan & Tilt Head (back view, showing connection panel)

Front

Figure 57 shows the front of the X350 head.

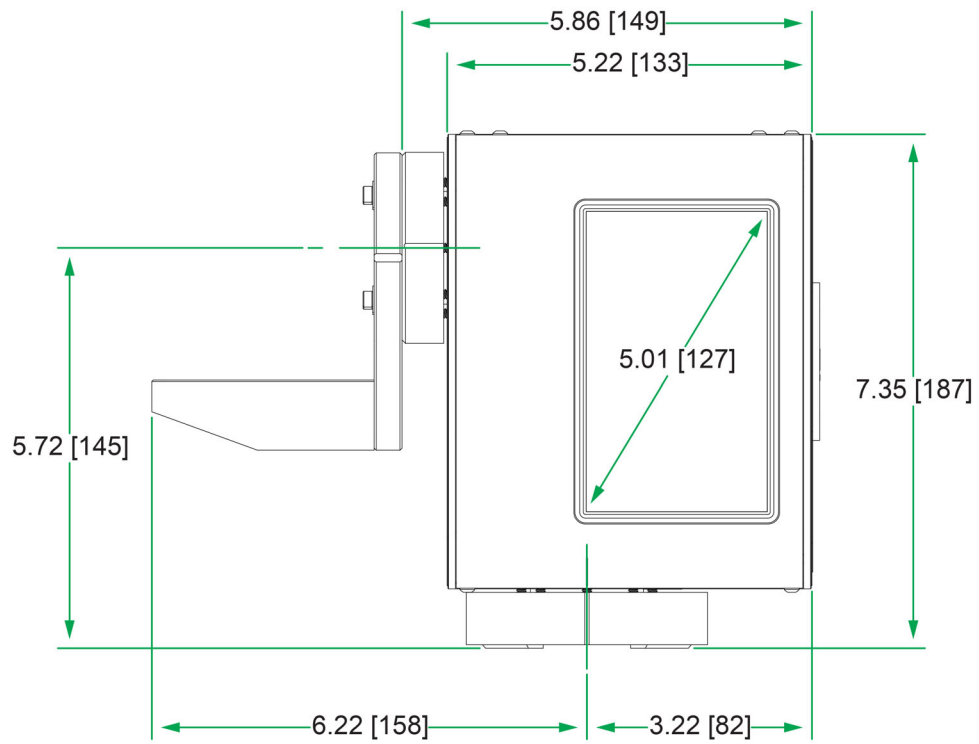

Figure 65 - X350 Pan & Tilt Head (front view)

Right Side (camera cradle side)

Figure 58 shows the right side of the X350 head.

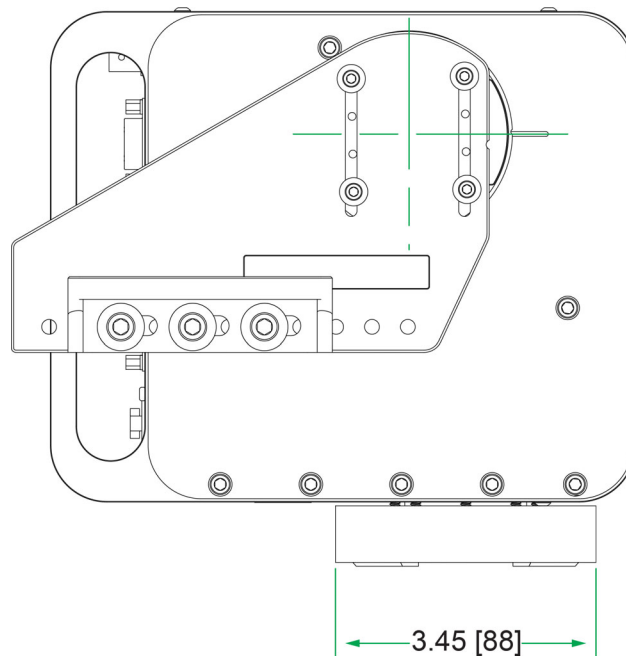

Figure 66 - X350 Pan & Tilt Head (right side)

Left Side

Figure 59 shows the left side of the X350 head.

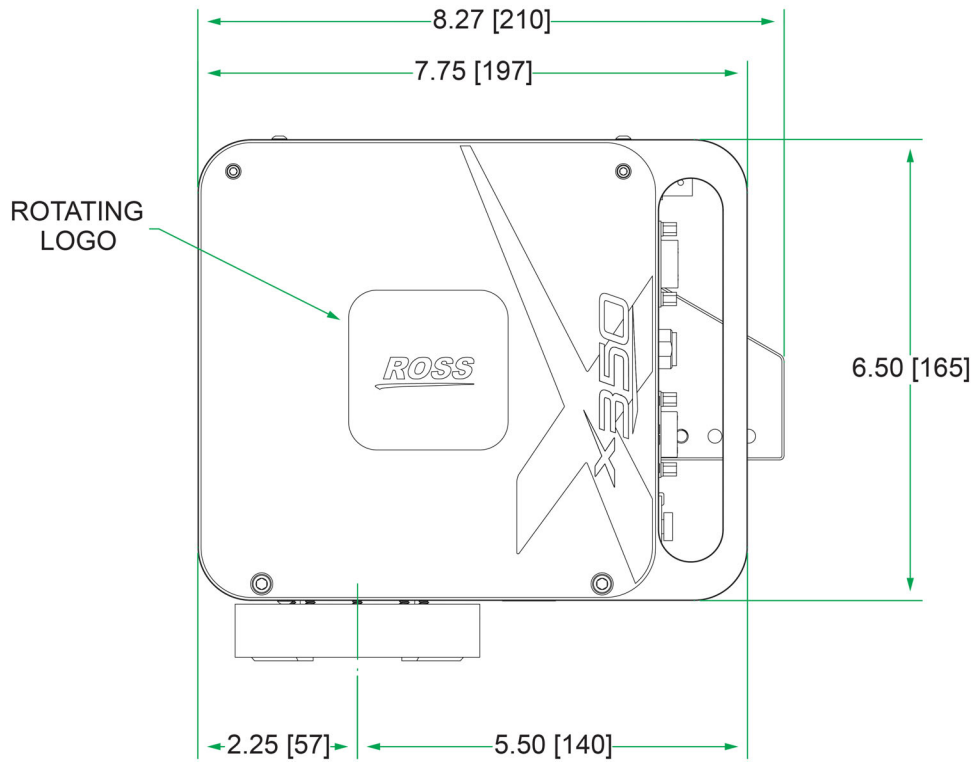

Figure 67 - X350 Pan & Tilt Head (left side)

Bottom

Figure 60 shows the bottom of the X350 head, without the camera cradle. For a drawing that shows mount hole spacing, see **Figure 3**.

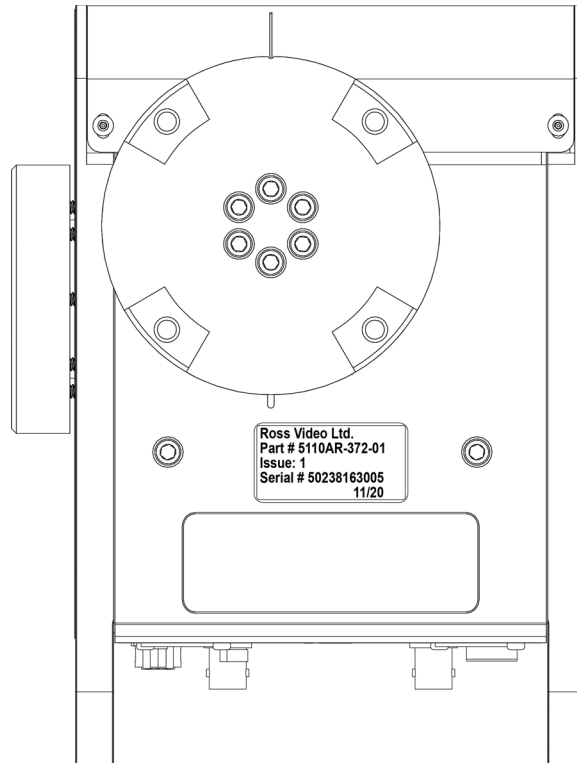

Figure 68 - X350 Pan & Tilt Head (bottom view, camera cradle not shown)

Top

Figure 61 shows the top of the X350 head.

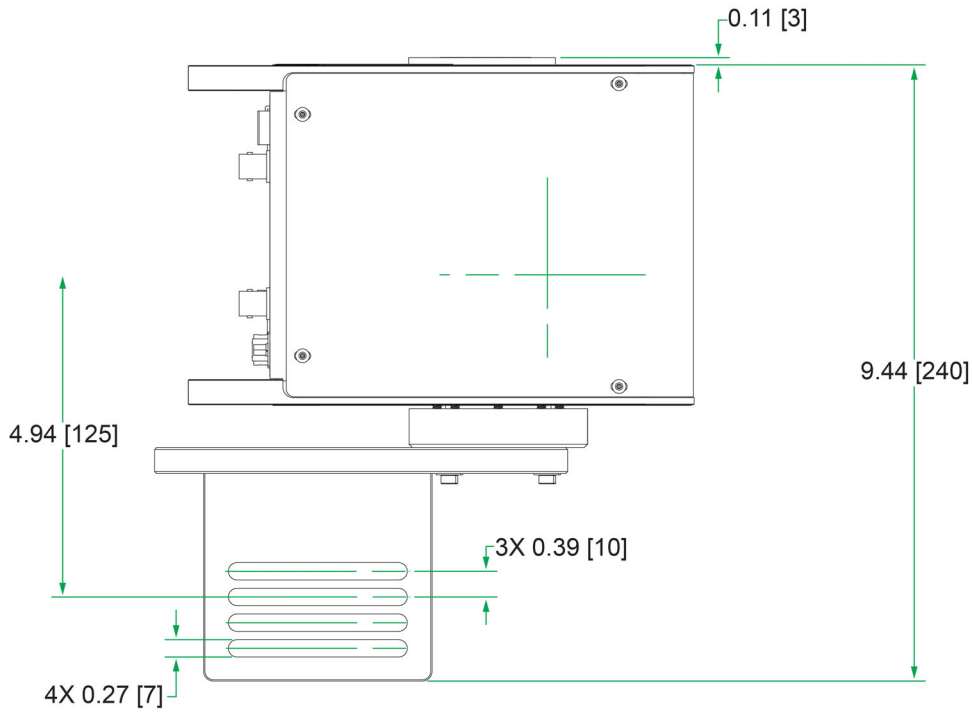

Figure 69 - X350 Pan & Tilt Head (top view)

Angled Views (X350 head mounted on a PM8 pedestal riser)

Figure 56 shows the front of the X350 head, mounted on a PM8 Pedestal Riser.

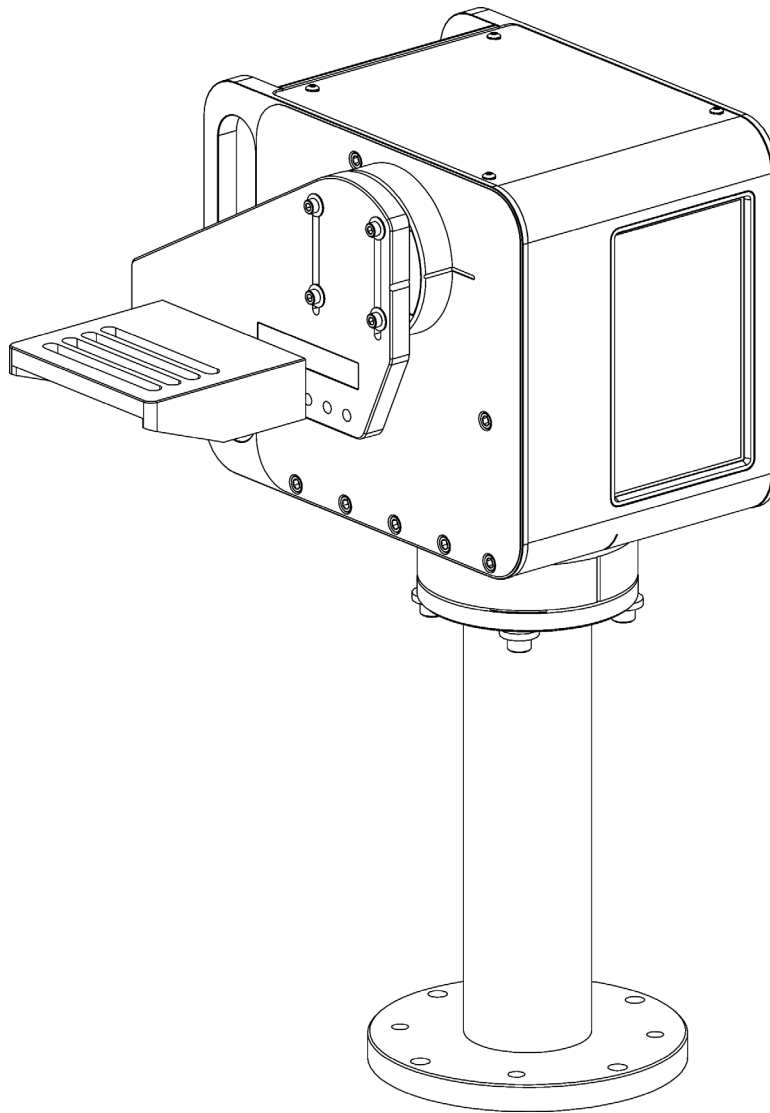

Figure 70 - X350 Pan & Tilt Head, Mounted on a PM8 Pedestal Riser (front angled view)

Figure 56 shows the back of the X350 head, mounted on a PM8 Pedestal Riser.

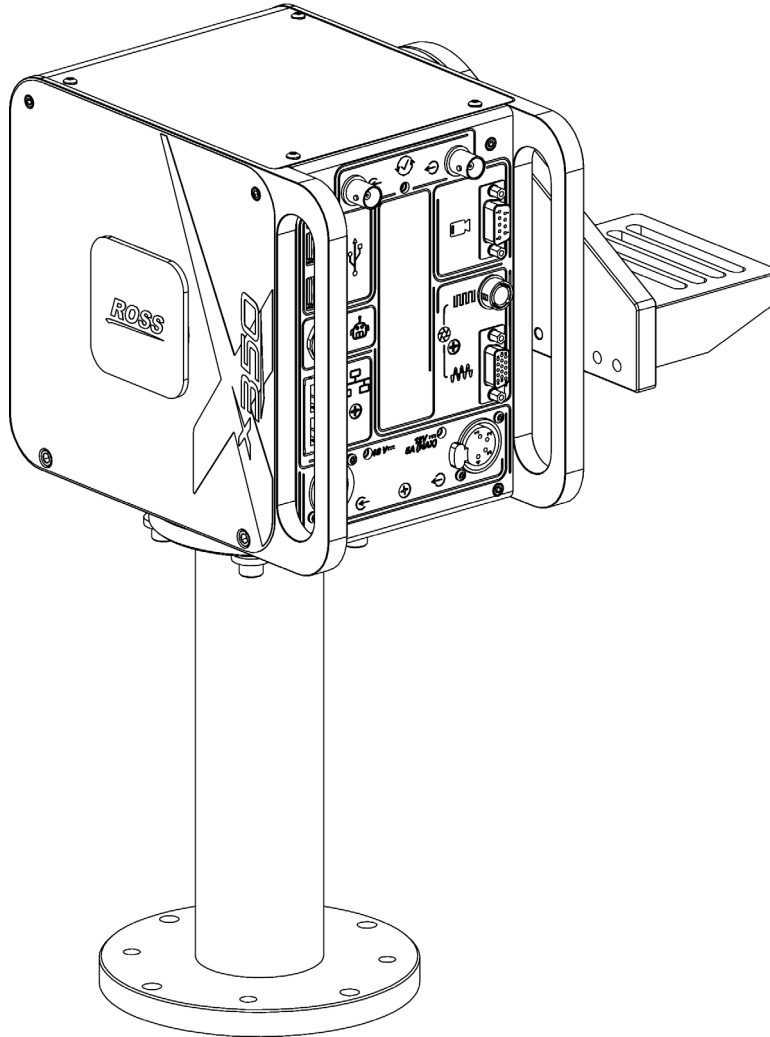

Figure 71 - X350 Pan & Tilt Head, Mounted on a PM8 Pedestal Riser (back angled view)

Drawings of the X650 Pan & Tilt Head

This section contains the following drawings:

- **“Back (connection panel)”**
- **“Front”**
- **“Right Side (camera cradle side)”**
- **“Bottom”**
- **“Top”**

Note: Drawings are not to scale. All dimensions are in inches and millimeters [mm].

Back (connection panel)

Figure 56 shows the back of the X650 head, including the connection panel.

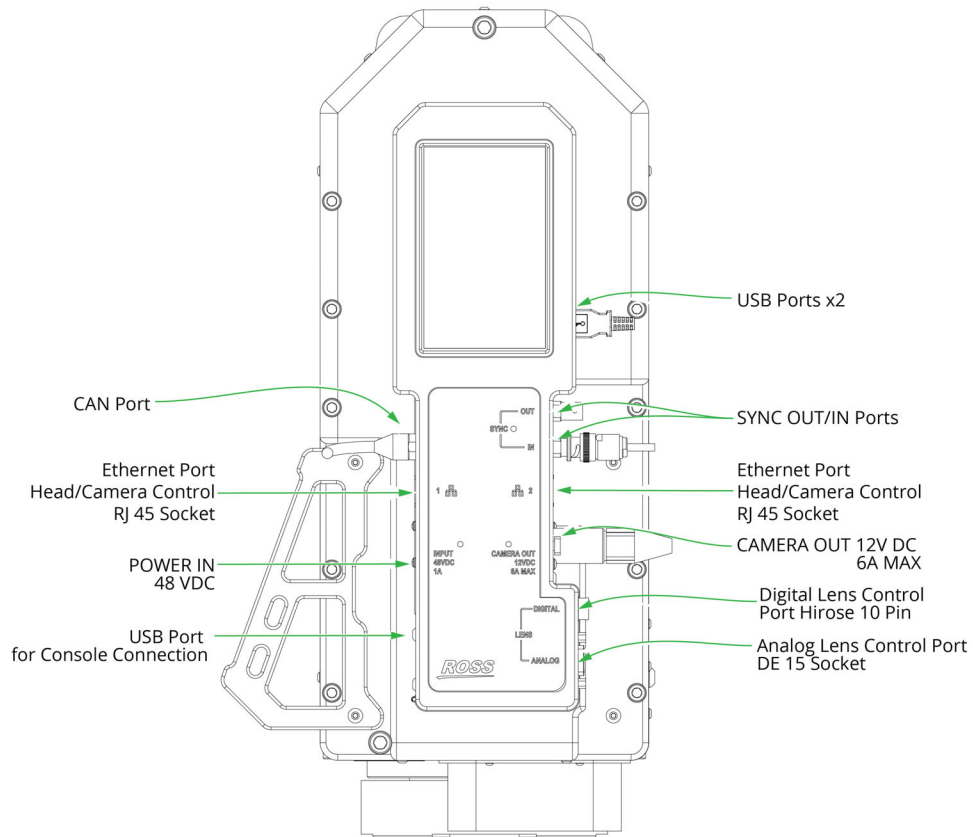

Figure 72 - X650 Pan & Tilt Head (back view, showing connection panel)

Front

Figure 57 shows the front of the X650 head.

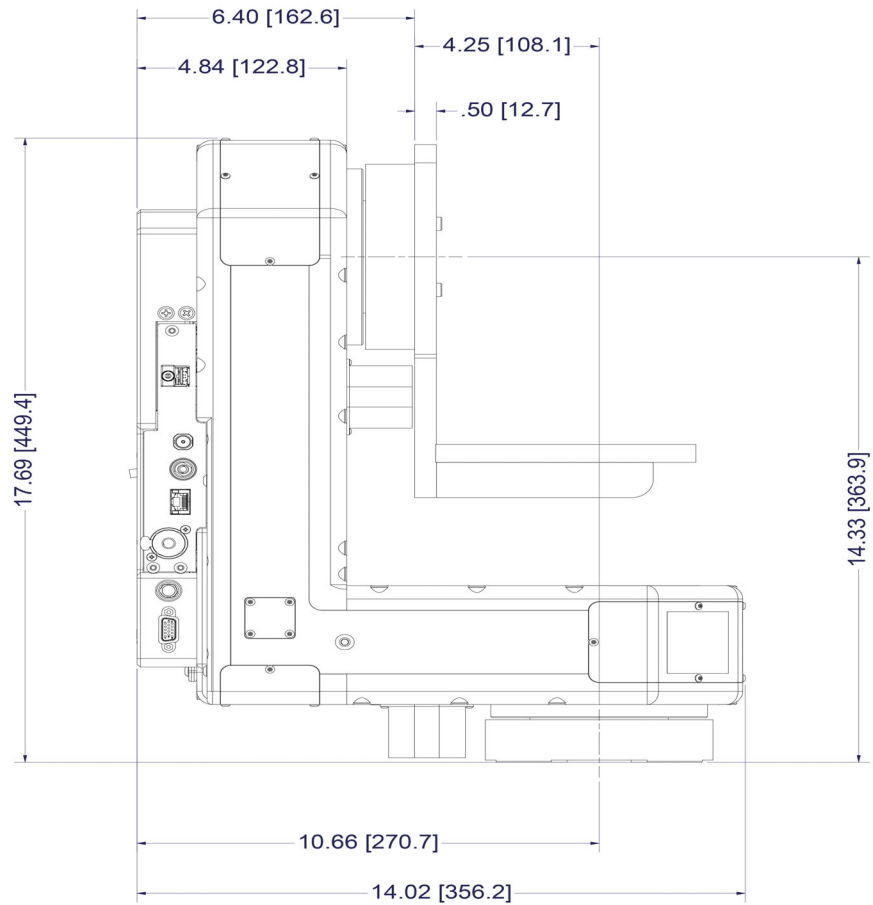

Figure 73 - X650 Pan & Tilt Head (front view)

Right Side (camera cradle side)

Figure 58 shows the right side of the X650 head.

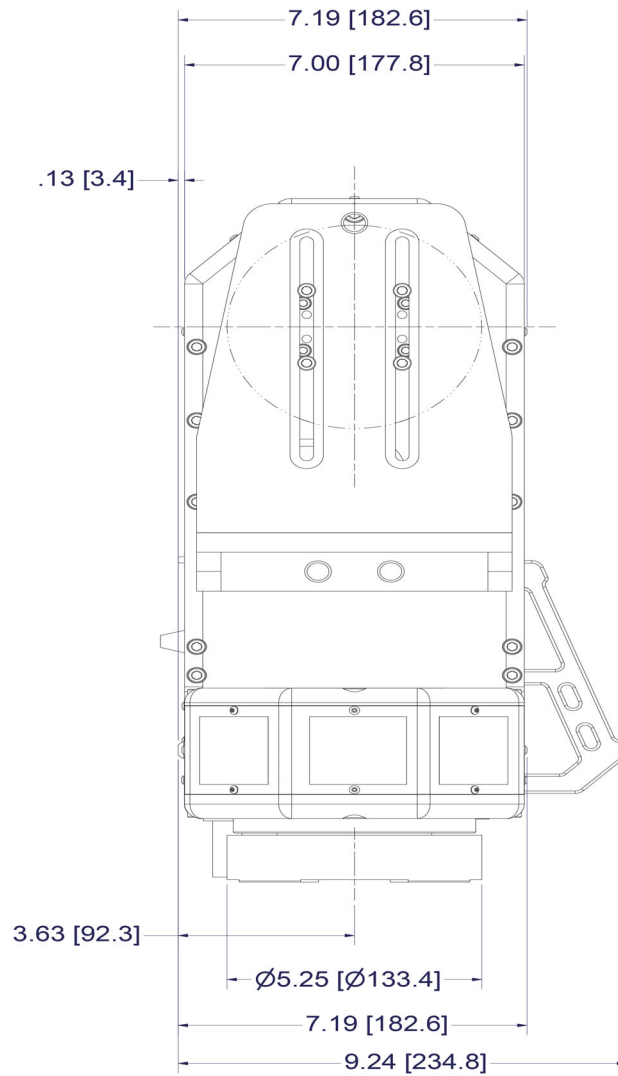

Figure 74 - X650 Pan & Tilt Head (right side)

Bottom

Figure 60 shows the bottom of the X650 head, without the camera cradle. For a drawing that shows mount hole spacing, see **Figure 3**.

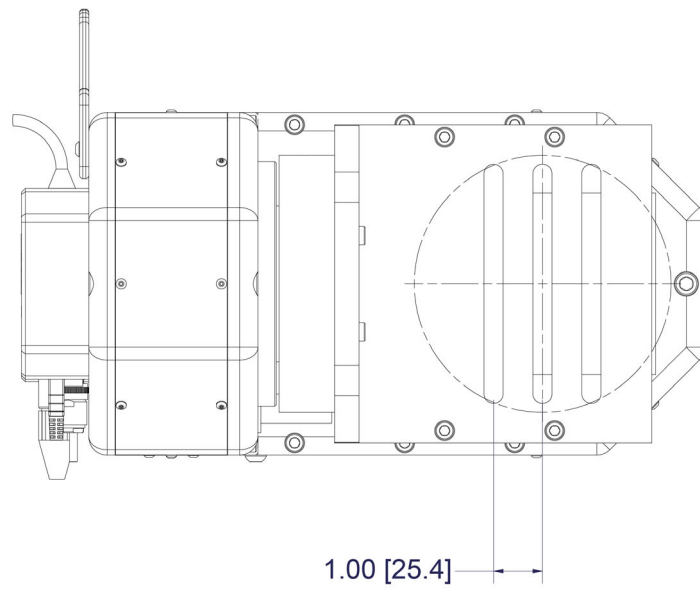

Figure 75 - X650 Pan & Tilt Head (bottom view, camera cradle not shown)

Top

Figure 61 shows the top of the X650 head.

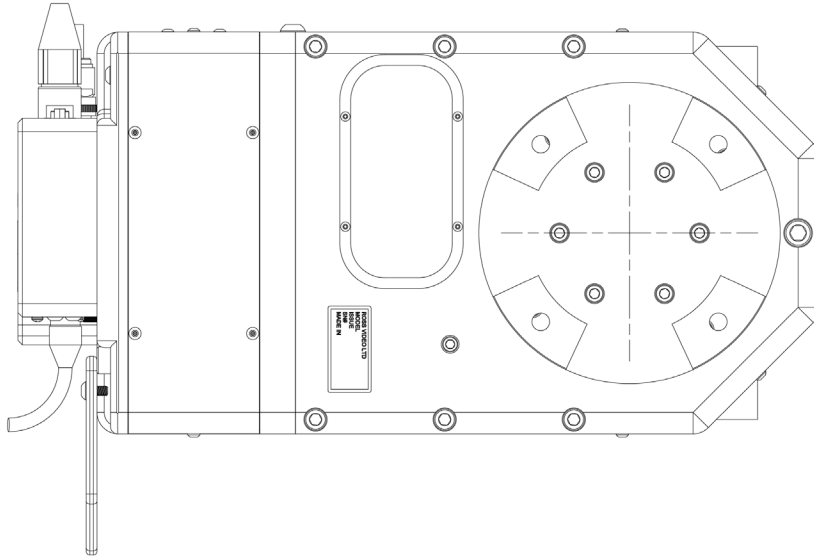

Figure 76 - X650 Pan & Tilt Head (top view)

Connector Pin Assignments

This section lists pin assignments for connectors on X300, X350 and X650 heads. It includes the following topics:

- **"Digital Lens Control Port — Pin Assignments (X350 and X650 only)"**
- **"Analog Lens Control Port — Pin Assignments"**
- **"Serial Camera Control Port — Pin Assignments (X350 only)"**
- **"Power Input — Pin Assignments"**
- **"Power Output— Pin Assignments (X350 and X650 only)"**

Digital Lens Control Port — Pin Assignments (X350 and X650 only)

Figure 77 shows the pin assignments for the digital lens control port (10-pin Hirose connector).

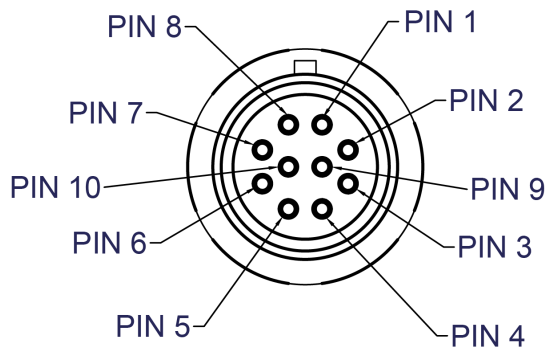

WIRING TABLE	
PIN	SIGNAL
1	RS422_TX-
2	RS232_RX
3	RS232_TX
4	RS232 DTR
5	GND
6	N/C
7	RS422_TX+
8	RS422_RX+
9	RS422_RX-
10	DETECT1

LENS CONTROL - DIGITAL
PIN ASSIGNMENT
(LOOKING AT CONNECTOR)

Figure 77 - Pin Assignments for the Digital Lens Control Port

Analog Lens Control Port — Pin Assignments

Figure 77 shows the pin assignments for the analog lens control port (DE 15 socket).

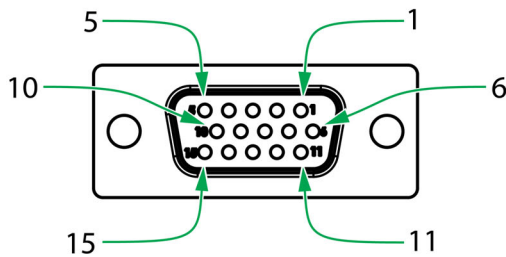

LENS CONTROL - ANALOG
PIN ASSIGNMENT
(LOOKING AT CONNECTOR)

WIRING TABLE	
PIN	SIGNAL
1	V1_ZOOM
2	V2_ZOOM
3	V3_ZOOM
4	CABLE_DETECT1
5	IRIS_DEMAND
6	FOCUS_DEMAND
7	ZOOM_DEMAND
8	V1_FOCUS
9	V2_FOCUS
10	V3_FOCUS
11	IRIS C/L
12	CABLE_DETECT2
13	CABLE_DETECT3
14	CABLE_DETECT4
15	GND

Figure 78 - Pin Assignments for the Analog Lens Control Port

Serial Camera Control Port — Pin Assignments (X350 only)

Figure 77 shows the pin assignments for the serial camera control port (DB 9 socket).

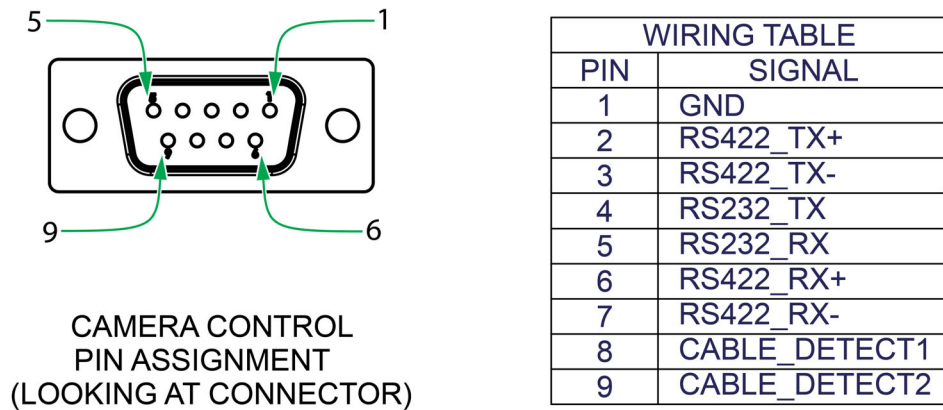
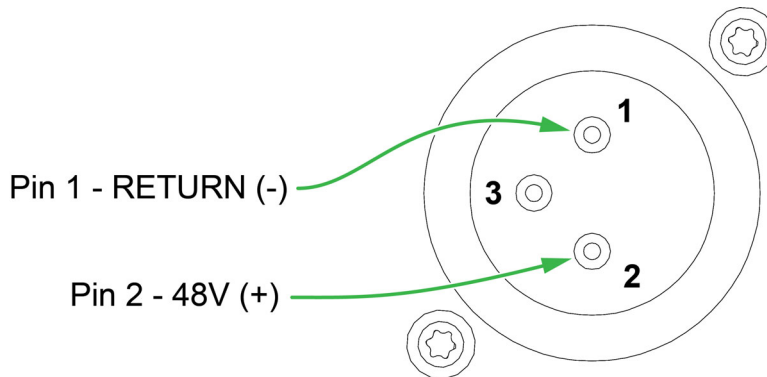

Figure 79 - Pin Assignments for the Serial Camera Control Port

Power Input — Pin Assignments

Figure 77 shows the pin assignments for the POWER IN port (3-pin XLR)



POWER INPUT 48 VDC
PIN ASSIGNMENT
(LOOKING AT CONNECTOR)

Figure 80 - Pin Assignments for the POWER IN Port

Power Output— Pin Assignments (X350 and X650 only)

Figure 77 shows the pin assignments for the POWER OUT port (4-pin XLR)

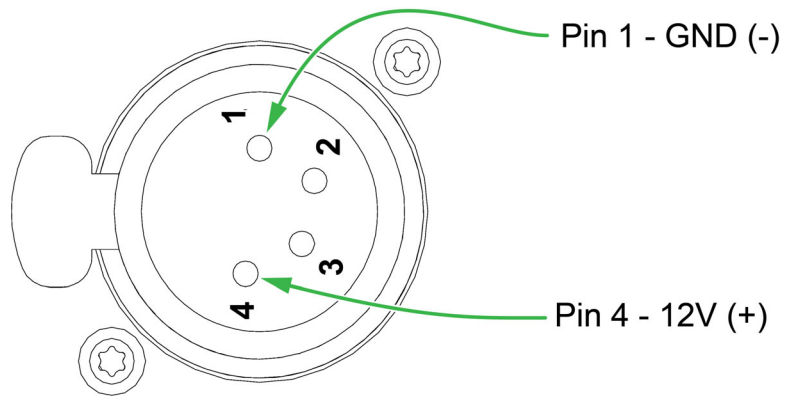

POWER OUTPUT 12 VDC (5 A MAX)
PIN ASSIGNMENT
(LOOKING AT CONNECTOR)

Figure 81 - Pin Assignments for the POWER OUT Port

Optional Mounting Accessories

This section describes the following mounting accessories and options available for the X-Series Pan & Tilt Heads. It includes the following topics:

- “PM8 Pedestal Riser for X300 or X350 (RRB-UNI-PM8)”
- “Universal Ceiling Mount for X300, X350, or X650 (RRB-UNI-CLM)”
- “Universal Wall Mount Bracket for X300 or X350 (RRB-UNI-WMB)”
- “Mitchell Mount Adapter for X300, X350, or X650 (RRB-UNI-MA)”

PM8 Pedestal Riser for X300 or X350 (RRB-UNI-PM8)

This is an 8” (20 cm) black metal pedestal riser with a flanged base and eight mounting holes (RRB-UNI-PM8). The PM8 Pedestal Riser can be mounted to any horizontal surface that accepts fasteners.

Figure 82 shows how the X350 is mounted to a PM8 Pedestal Riser.

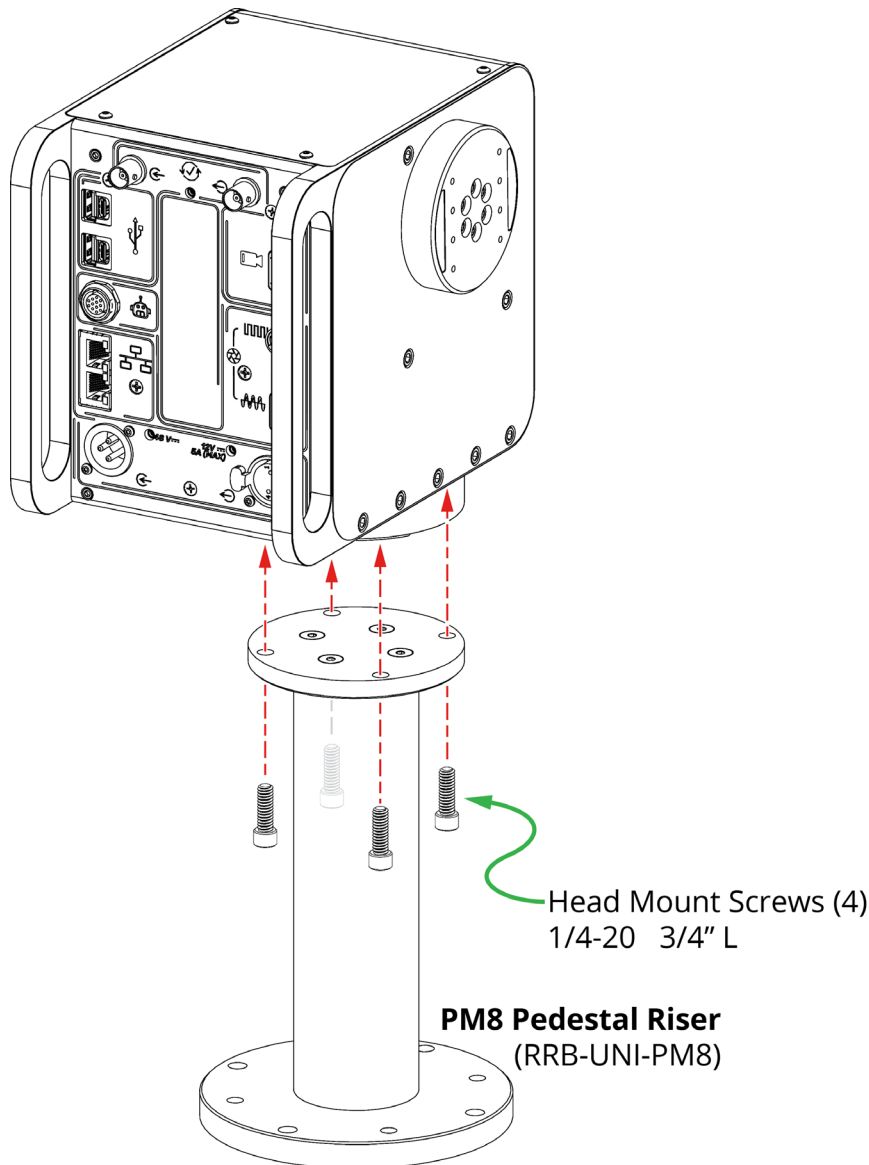

Figure 82 - Mounting the X350 Head on a PM8 Pedestal Riser

Universal Ceiling Mount for X300, X350, or X650 (RRB-UNI-CLM)

This mount clamps onto a section of lighting grid pipe, and is suitable for inverted mounting of the X300, X350, or X650 head. It is designed to accept nominal 1.5" Schedule 40 pipe, which has an outside diameter of 1.9" (48mm). The pipe outside diameter must be minimum 48mm (1.9"), maximum 51mm (2"). This sort of pipe is commonly used for lighting truss and studio lighting grids.

The Universal Ceiling Mount is used in conjunction with a PM8 Pedestal Riser, to increase clearance between the payload and the ceiling mount.

Figure 83 shows the Universal Ceiling Mount.

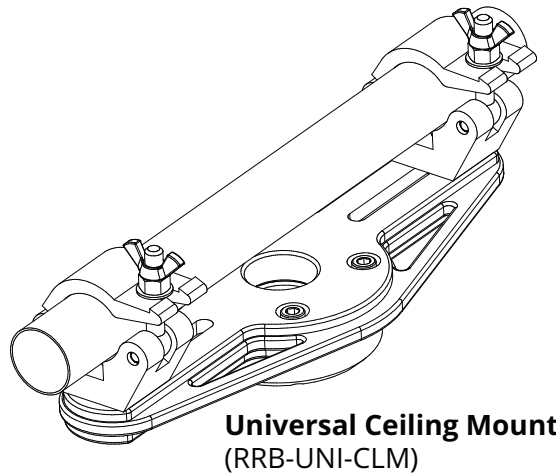

Universal Ceiling Mount
(RRB-UNI-CLM)

Figure 83 - Universal Ceiling Mount

Universal Wall Mount Bracket for X300 or X350 (RRB-UNI-WMB)

This is a sturdy metal bracket designed to fully support an X300 or X350 head without restricting pan and tilt range (RRB-UNI-WMB). The wall mount bracket must be securely fastened to a structural member, such as a wall stud.

Figure 83 shows the Universal Wall Mount Bracket.

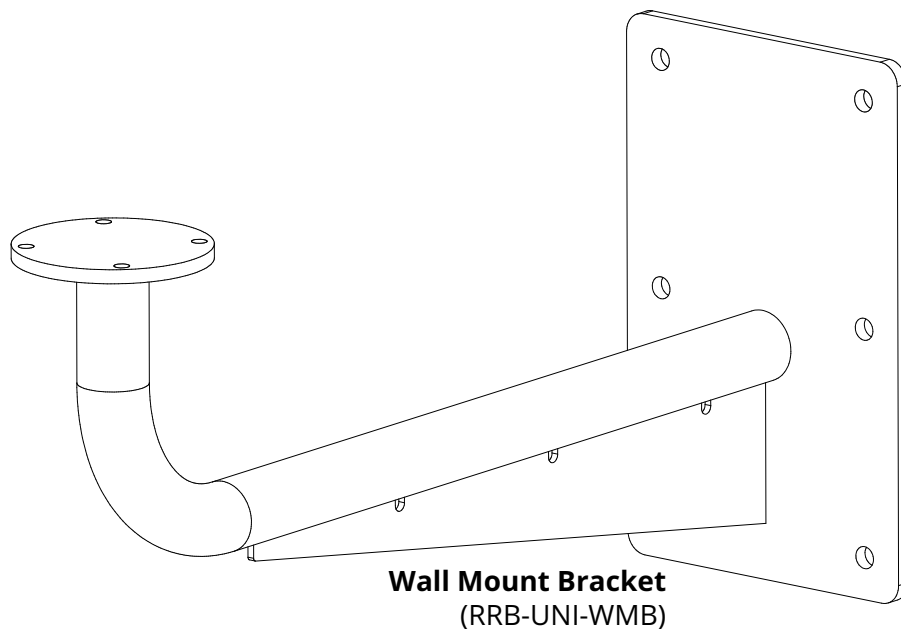

Wall Mount Bracket
(RRB-UNI-WMB)

Figure 84 - Universal Wall Mount Bracket

Mitchell Mount Adapter for X300, X350, or X650 (RRB-UNI-MA)

This adapter is designed for use with a tripod or pedestal that has a Mitchell Mount plate.

The Mitchell Mount Adapter is used in conjunction with a PM8 Pedestal Riser, as an adapter to mate it with the X300, X3350, or X650 head.

Tripods and Pedestals

Ross Video sells a variety of Cartoni tripods and pedestals suitable for mounting our robotic pan & tilt heads. A PM8 Pedestal Riser is also required, as a mating adapter.

Site Requirements

A Ross Robotics system consists of studio equipment and control room equipment.

This section describes the studio equipment and studio environment required to support Ross X300, X350, and X650 robotic pan & tilt heads.

Topics in this section include the following:

- “**Camera and Lens Control Options**”
- “**About Payload Design and Load Balancing**”
- “**General Studio Requirements**”
- “**Power and Networking Requirements**”

For More Information About...

- Control room site requirements for Ross Robotics systems that use a Standard SmartShell Control Station, which features separate computers for SmartShell and the Robotics Server, see ***Control Room Site Requirements for Standard Control Station (5100DR-021-xx)***.
- Control room site requirements for Ross Robotics systems that use a Standalone SmartShell Control Station with Integrated Server, see ***Control Room Site Requirements for Standalone Control Station with Integrated Server (5100DR-032-xx)***.
- Studio site requirements for Furio robots, see ***Furio Studio Site Requirements (5100DR-023-xx)***.
- Studio site requirements for CamBot robots, see ***CamBot Studio Site Requirements (5100DR-022-xx)***.
- Ross Robotics products and accessories, and for product brochures, contact your Ross Video sales representative.

Camera and Lens Control Options

X300, X350, and X650 heads can control focus, zoom, and iris functions.

Controlling camera and lens functions requires a cable connection between the head and the camera, and between the head and the lens.

Lens Control Options

The X300, X350, and X650 provide the following lens control options:

- Digital control of a wide range of Canon and Fujinon full servo serial lenses via a 10-pin Hirose socket on the head.
 - A lens control cable suitable for your lens is included (to be selected when ordering):
 - › for Fujinon RD/ZD drives (10-pin at lens): Ross part number FRO-VR1-DLF10.
 - › for Fujinon RD/ZD drives (20-pin at lens): Ross part number FRO-VR1-DLF20.
 - › for Canon IASE drives (20-pin at lens): Ross part number FRO-VR1-DLC.
- Analog lens control via a DE-15 socket.

Camera Control Options

Camera control options are as follows:

- Camera control over IP via one of two Ethernet ports (RJ45 jacks).
- Camera control over serial digital connection (RS232/422) via a DB-9 socket (X350 only).

Tip: If the camera can be controlled both over IP and through a serial digital connection, and you want to cascade (daisy-chain) the network connection from head-to-head, use the serial DB-9 socket for camera control. This leaves both Ethernet ports available for cascading the network connection.

About Payload Design and Load Balancing

Ross Video designed the drive train of the X300, X350 and X650 to perform smoothly, accurately, and reliably under full payload in demanding production environments.

We recommend you determine in advance which payload components will be mounted to the head, and how they will be secured.

The maximum payload of the X300 or X350 is 15 lbs (6.8 kg).

The maximum payload of the X650 is 125 lbs (57 kg).

For best results, design a payload that

- has a low moment of inertia (MOI). The MOI affects the amount of torque (rotational force) required to move the load. The smoothest starts and stops are achieved when the MOI is low. You can reduce the MOI by eliminating unnecessary payload weight, and by positioning as much of the weight as possible close to the tilt axis.
- can be balanced both horizontally and vertically around the tilt axis of the head, so its center of gravity is aligned with the tilt axis.

If safety tethers are required between the payload and the head, or between the head and a fixed point in the studio, consider the following:

- Tethers must be looped through both handles of the head, or through only the handle on the **payload side** of the head (preferred).
- All tethers must allow the full range of pan & tilt motion without excess slack, and without obscuring the camera lens.
- Safety tethers must not be dressed (bundled or zip-tied)!

General Studio Requirements

All Ross Robotics equipment must be installed and operated in a suitable physical environment:

- Equipment must be installed in an indoor location not exposed to moisture.
- Acceptable operating humidity range is 10% to 90% RH, non-condensing.
- Acceptable operating temperature range is 0° C to 45° C (32° F to 113° F).
- Acceptable storage and transport temperature range is -30° C to +70° C (-22° F to 132° F).

After exposure to temperatures beyond the acceptable operating temperature range, the temperature of the head must be brought to within the acceptable operating range before use.

Note: Ross Video does not provide Ethernet cables, power supply cables, sync reference cables, or video cables. Such cables are selected or custom-made to suit the facility, and are to be provided by the systems integrator or the customer.

Power and Networking Requirements

Power and networking requirements for X300 or X350 pan & tilt heads are as follows:

- One AC power supply socket per head.

Each head comes with an auto-sensing power adapter that meets the following specifications:

- › **Input:** Auto-sensing, accepting voltages between 85 VAC and 264 VAC, at a frequency of 47 Hz to 63 Hz.
- › **Output:** 48 VDC, 3.3 A, 160 W.
- › **Cabling:** Included with each head is a line cord with plug suitable for the country where the system is to be installed. The output of the power adapter is a 3-pin female XLR plug that connects to the head.
- › **Physical dimensions for the X300/350:** Approximately 2 7/8" x 1 3/8" x 6 7/8" (72 mm x 35 mm x 175 mm).
- › **Physical dimensions for the X650:** Approximately 17" x 11" x 7" (432 mm x 279 mm x 178 mm).

As an alternative to the provided power adapter, you can use a third-party power supply such as a rack-mounted power distribution unit:

- › Read and follow all instructions and guidelines provided by the manufacturer of the power supply equipment.
- › Follow all national and local electrical, fire, and building codes when installing power supply equipment and cables. Use DC circuit breakers when required.
- › The power supply must be capable of providing 160W minimum (48 VDC at 3.33 A). To avoid excessive voltage drop, the maximum DC cable length using 16 AWG conductors is 300' (91.4 m). Minimum tolerated voltage at the head is 36 VDC.
- › The power input connector on the head is a 3-pin male XLR plug (conforms to IEC 61076-2-103).
- › For the 3-pin female XLR socket, we recommend Neutrik NC3FXX.
- › Pin assignments are as follows: Pin 1 - RETURN (-); Pin 2 - 48 V (+); Pin 3 - not connected. See **Figure 85**.

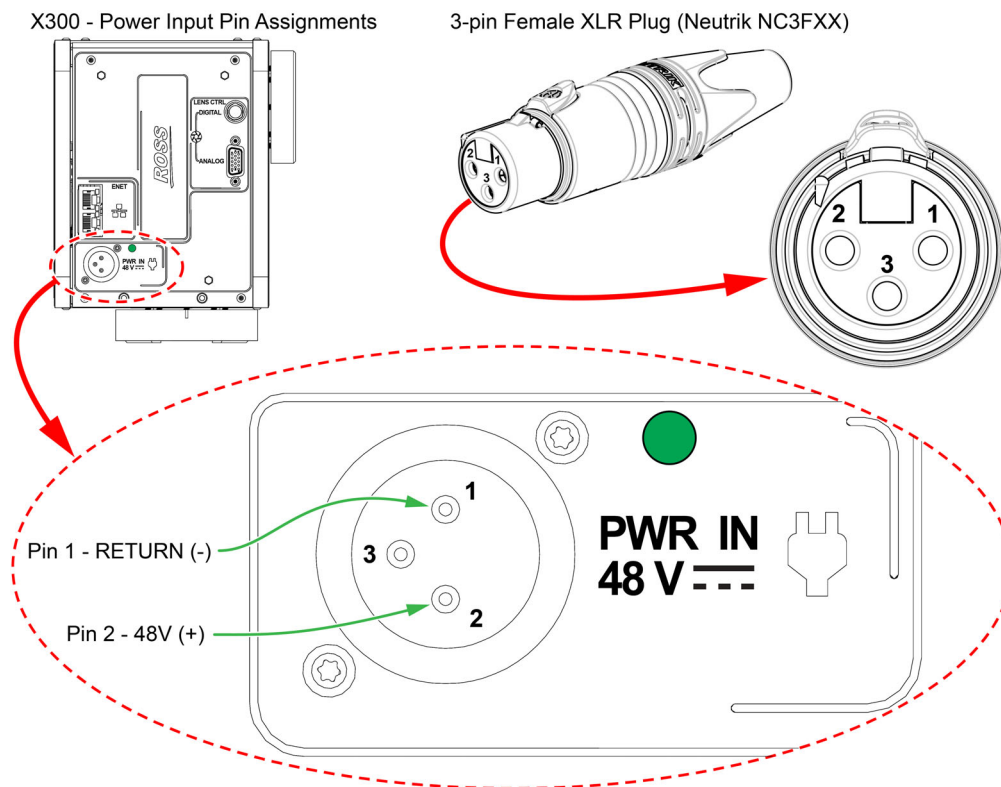

Figure 85 - Power Input Pin Assignments (X300 shown; X350 and X650 power inputs are identical)

- Circuit protection: The power supply circuit must be protected by a 15 A fuse or circuit breaker (for 120 VAC circuits), or an 8 A fuse or circuit breaker (for 240 VAC circuits).
- Ethernet connection to 100/1000 network:
 - › Each robotic head has two female RJ45 Ethernet ports for connecting to the IP network, and to the camera if camera control over IP is required.
The head has an integrated 1x2 Ethernet switch, which enables daisy-chaining of heads unless one of the Ethernet ports is required for camera control over IP.
 - › The Ethernet cable must be stranded CAT5E, and the end that plugs into the head must terminate in a male RJ45 plug.
 - › The maximum cable distance between network nodes is 328' (100 m). This range can be increased using an Ethernet extender (not provided).
- One sync reference cable per X350 head, terminating in a male standard BNC plug which connects to a female standard BNC socket on the head.
This applies only to X350 and is required only for AR/VS (Augmented Reality and/or Virtual Set) applications.
AR/VS applications require that the same sync reference signal be delivered to each robot, to each camera, and to the AR/VS graphics rendering system.
Tip: The X350 and X650 also feature a **SYNC OUT** port (standard BNC) that enables you to provide the sync signal to another device.
- All cables that run to a robotic head must contain stranded conductors only. Solid conductors are not acceptable because they are more likely to deteriorate due to robotic movement, causing intermittent data transmission. It is also important to use very light, flexible cables to reduce drag.
- All cables must be properly dressed to
 - › allow the full range of pan & tilt motion without obscuring the camera lens
 - › avoid strain and load on the head
 - › avoid physical damage to the cables, such as can be caused by foot traffic, rolling equipment, etc.
 - › prevent risk to personnel, such as can be caused by tripping over loose cables

- Camera and accessory cables as required, including power extension cables, video cables, etc.