

Assembly

1

Attaching the Camera Cradle

Fasten the cradle to the head using the four bolts and four washers provided.

The head has eight holes. Fasten two bolts into the top two holes, and two bolts into the bottom two holes. Do not over tighten.

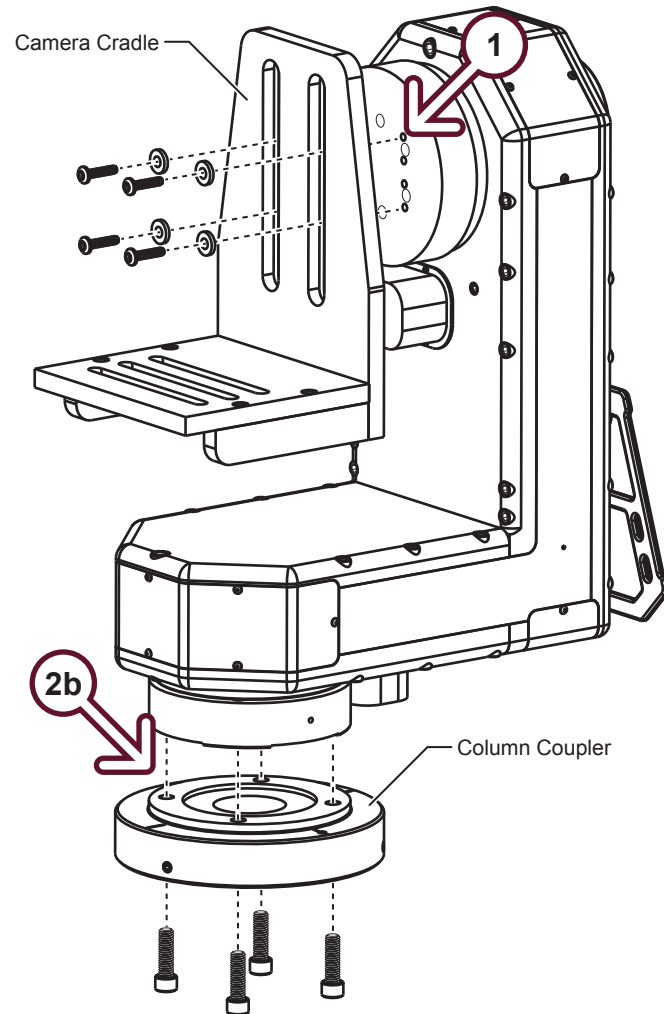

2

Attaching the Furio Column Coupler

If you are using the VR600 with a Furio column, attach the provided column coupler to the head.

2a Align the orientation mark on the coupler with the drilled orientation hole on the base of the head.

2b Fasten the coupler to the head using the four bolts provided. Do not over tighten.

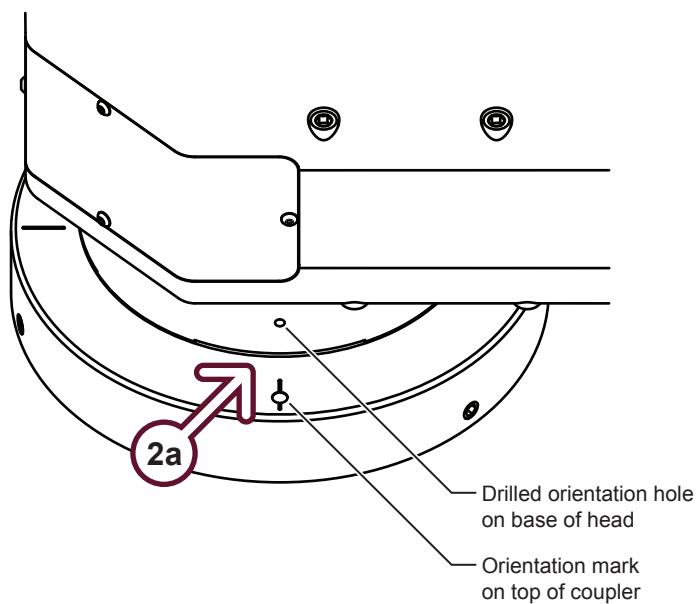

Drilled orientation hole on base of head
Orientation mark on top of coupler

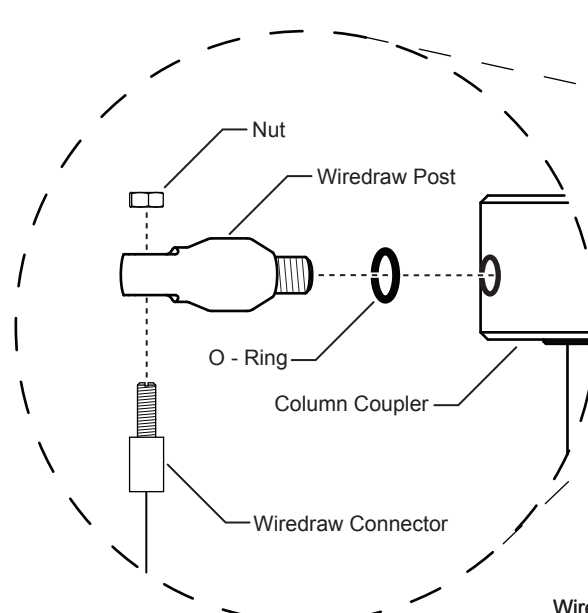
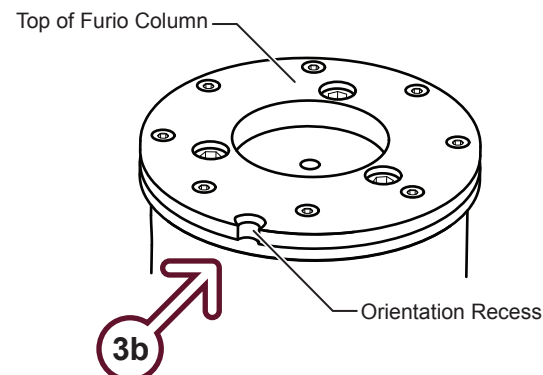

3

Mounting onto a Furio Column

Mounting onto a Furio Column

SAFETY NOTICE: Two people are required to lift and mount the head. The head is heavy and can cause injury and/or be damaged if dropped.

3a If the column is a lift column, lower it completely and turn off power to the system.

3b Note the orientation recess on the top of the column, and the corresponding flange on the bottom of the column coupler. These must align when you mount the head.

3c Keeping the head level at all times, lift the head onto the column.

3d Rotate the head until the orientation recess on the top of the column engages with the corresponding flange on the bottom of the column coupler. Ensure that the head is well seated on the column and does not rock.

3e Fasten the column coupler to the column by tightening the three set screws embedded in the edge of the coupler. Do not over tighten.

4

Attaching the Wiredraw Cable

If you are using a Furio lift column, attach the vertical wiredraw cable to the head.

4a Slide the rubber O-ring over the threaded end of the wiredraw post.

4b Gently screw the wiredraw post into the mounting hole on the column coupler.

Tip: The O-ring allows for adjustment of the wiredraw post. Ensure that the hole in the wiredraw post is vertical so it can accept the wiredraw connector.

4c At the wiredraw unit, which is mounted on the dolly, remove the nut from the wiredraw connector.

4d Gently lift the wiredraw connector up towards the head, slide the connector through the wiredraw post, and then reattach the nut.

IMPORTANT: Never allow the wiredraw to snap back into the wiredraw unit.

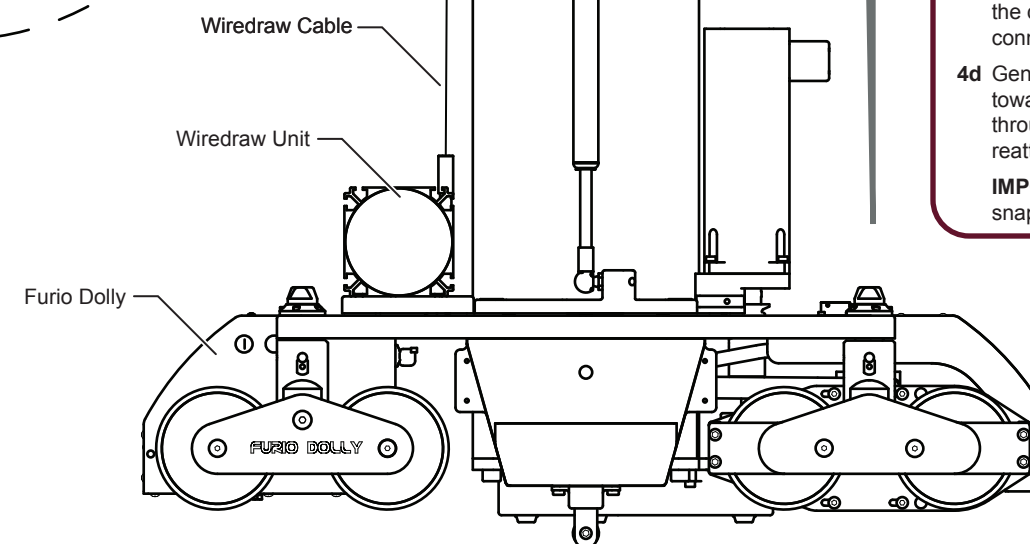

?

Need Help?

Technical Support: (+1) 613 • 652 • 4886
Email: techsupport@rossvideo.com

Mounting Without a Furio Column

5 Mounting Without a Furio Column

SAFETY NOTICE: Two people are required to lift and mount the head. The head is heavy and can cause injury and/or be damaged if dropped.

Mount the head to the support apparatus using four bolts (3/8" 16 UNC) of suitable length.

Bolt penetration into the head is to be minimum 0.625" [16mm] and maximum 1.125" [29mm].

Cabling the Head

6 Position Tracking Data (optional)

The VR600 head emits synchronized position tracking data, which is used for virtual reality and augmented reality applications. The data can be synchronized with an external reference signal at 50Hz or 60Hz. If no external signal is provided, the head generates an internal 50Hz sync pulse and emits tracking data at a rate of 50 times per second (50Hz). Tracking data is output to up to three UDP/IP destinations, and through a RS232/RS422 serial connection.

6a If you want the head to generate tracking data synchronized to an external reference signal, connect the reference signal to the **VIDEO SYNC** connector on the head.

6b If you want to access tracking data through the serial connection, connect to the **RS232/RS422** connector on the head.

7 Lens Control

The Furio system controls the camera lens. If the lens is not designed to provide lens position data, external encoders can be attached to generate the data and send it to the Furio system.

7a Connect a lens control cable to the **LENS DRIVE** connector on the head, and to the corresponding connector on the lens.

7b If using an external focus encoder on the lens, connect a data cable between the **FOCUS ENC** connector on the head, and the corresponding connector on the focus encoder.

7c If using an external zoom encoder on the lens, connect a data cable between the **ZOOM ENC** connector on the head, and the corresponding connector on the zoom encoder.

8 Network

8a If you are using a Furio dolly, connect a Furio data cable between one of the **NETWORK** connectors on the head, and the middle **CAN** connector on the dolly.

8b Connect an Ethernet cable to the **ETHERNET** connector on the head, and to the network.

9 Power

9a If you are using a Furio column, mount the power supply bracket, replacing a handle. For more information, see *Installing the VR600 Power Supply Bracket (5100DR-011)*.

9b Connect the power supply cable to the **POWER** connector on the head, and to the power supply unit.

9c Connect the power supply unit to an appropriate power source. For more information, see *VR600 Site Requirements (5100DR-009)*.

Note: The head does not have an ON/OFF switch. It starts when connected to power.

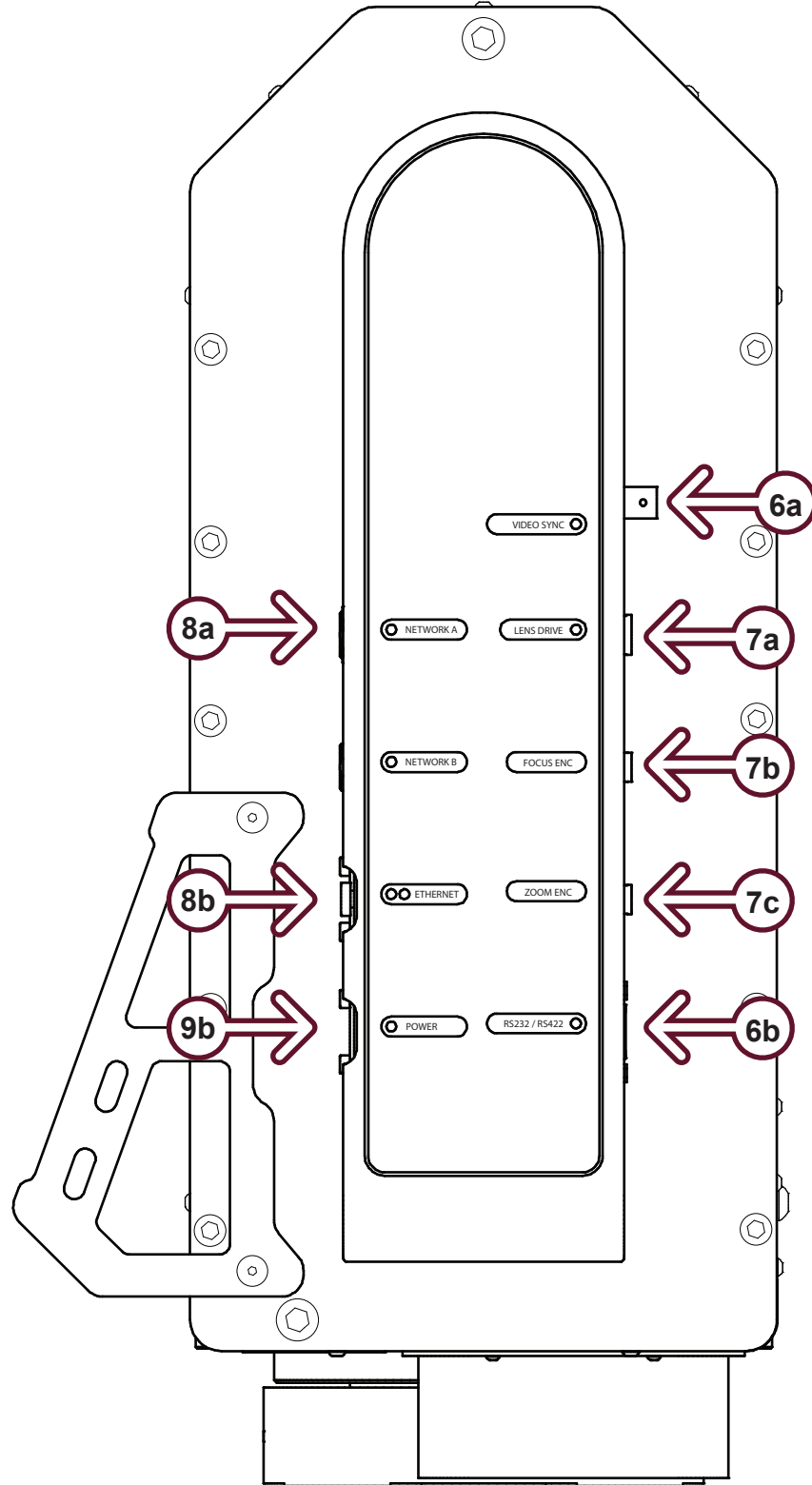

Testing the Head

10 Configuring the IP Address

10a Turn on the power supply to the head, and then turn on the SmartShell computer.

10b On the SmartShell computer, open Internet Explorer and navigate to <http://10.42.3.64>. The head configuration interface appears.

10c On the **IP Settings** tab, specify a new, unique IP address for the head.

10d Click **Save and Reboot**.

11 Registering the Head in SmartShell

11a On the SmartShell computer, open the file **smartshell.exe.config** in a text editor.

11b In the **<VROne>** section, create a duplicate of one of the camera entries.

Tip: Each camera entry starts with **<VROne** and ends with **</VROne>**.

11c In the camera entry you created, in the **<VROne>** tag, change the value of the Name attribute to the camera name for the head. This name will appear in SmartShell.

11d In the **<Connection>** tag, replace **localhost** with the head's IP address.

11e In the **<Axis Settings>** section, delete any **<Axis>** tag entries that do not apply.

11f Save the **smartshell.exe.config** file.

12 Testing the Head

12a On the SmartShell computer, start SmartShell by double-clicking **SmartShell.exe**.

12b Click the head's camera name at the top of the window, and then click **Operate**.

SmartShell enables and homes the axes. This may take up to 30 seconds. If any fail to home, note the problem and click **SKIP**.

12c Using SmartShell and the Joystick Panel, test each axis of the head.

Loading and Balancing

13 Preparing and Mounting the Payload

SAFETY NOTICE: Two people are required to lift and mount the payload. The payload is heavy and can cause injury and/or be damaged if dropped.

13a Turn off power to the head, and then assemble the payload, including everything that will be mounted on the head.

13b Lift the load onto the head and fasten it down. Attach all cables. Bundle and fasten them to the cable bracket, allowing enough slack for head movement. Encase them in a suitable sleeve.

14 Balancing the Payload

14a Gently tilt the cradle until the payload is horizontal, then release it. If the cradle does not start to tilt, the load is balanced horizontally. Otherwise, adjust the payload position until it is balanced. When balanced, mark the position of the payload precisely.

14b Gently tilt the cradle to about 30 degrees, then release it. If the cradle does not start to tilt, the load is balanced vertically. Otherwise, remove the payload, loosen the cradle bolts, raise or lower the cradle as needed, retighten the bolts, then remount the payload and check again.