

Furio Studio Site Requirements

A Ross Robotics system consists of control room equipment and studio equipment.

This document specifies site requirements for Furio studio equipment. It includes the following sections:

- “**About the Ross Robotics System**” on **page 2**
- “**General Studio Requirements**” on **page 5**
- “**Power and Networking Requirements**” on **page 6**
- “**Accommodating Furio Tracks and Furio SE Robotic Dollies**” on **page 9**

Ask Us Anything — Ross Video is pleased to provide guidance and answer any questions you might have about planning your installation. Our friendly, experienced Project Managers can help you achieve an efficient and trouble-free installation.

IMPORTANT: Ross Robotics always strives to provide excellent customer service. Installation of equipment provided by Ross Robotics must be performed by Ross-qualified personnel only. If any non-qualified persons unpack and/or attempt to install equipment provided by Ross Robotics, the warranty is voided, and any actions required to correct the installation and/or repair the equipment will be at the expense of the customer and/or systems integrator.

For More Information about...

- Studio site requirements for CamBot robots, see ***CamBot Studio Site Requirements (5100DR-022-XX)***.
- Control room site requirements for Ross Robotics systems that use a Standard SmartShell Control Station, which features separate computers for SmartShell and the Robotics Server, see ***Control Room Site Requirements for Standard Control Station (5100DR-021-XX)***.
- Control room site requirements for Ross Robotics systems that use a Standalone SmartShell Control Station with Integrated Server, see ***Control Room Site Requirements for Standalone Control Station with Integrated Server (5100DR-032-XX)***.
- Ross Robotics products and accessories, and for product brochures, contact your Ross Video sales representative.

About the Ross Robotics System

Robots in the studio are controlled from the control room through a computer application named SmartShell, and the SmartShell Joystick Panel. The SmartShell computer communicates with robots and other components over a dedicated Ethernet network.

A single Ross Robotics system can include a variety of Artimo, CamBot, and Furio robots, all controllable from a single operator position. Some systems include multiple operator positions, each with its own SmartShell computer and SmartShell Joystick Panel.

The system can also control selected third-party robots. For more information, contact Ross Video.

Furio Robot Packages

Every Furio robotic camera system includes a Furio pan-tilt head (X350, VR600, or VR100). The head is mounted in one of the following ways:

- Standalone on a fixed column, tripod, wall bracket, or lighting grid pipe (inverted)
- On a track-mounted robotic dolly, with or without robotic lift
- On a manual pedestal with robotic lift

IMPORTANT: The VR100 pan/tilt head is End of Production (EOP) since June 16th 2023, and End of Support (EOS) on June 16th, 2030.

Product support is available for 7 years following the EOP date. Hardware maintenance is available to purchase but cannot exceed the EOP date. To learn more about upgrading your Furio Robot Package, contact your regional sales manager.

Furio PT Head Packages (head only)

Furio pan/tilt head packages are as follows:

- **FRO-X350-PT** — Furio X350 pan/tilt head, ideal for box style cameras, broadcast or cine style lenses and no prompter.

Key Features and Specs:

- › Payload: 6.8 kg (15 lbs) when mounted on Furio dolly
 - › Maximum pan/tilt speed: 45 degrees per second
 - › Net weight of head: 5.3 kg (11.6 lbs)
 - › 5" touchscreen display that aids setup and configuration, which can be used as a Tally/camera number
 - › Options for powering the camera, as well as cascading Ethernet and Genlock connections that simplify cable management
 - › Encoded pan and tilt motors. Suitable for virtual set and augmented reality applications
- **FRO-VR600-PT** — Furio VR600 pan/tilt head, ideal for larger cameras, lenses, and prompting systems.
Key Features and Specs:
 - › Payload: 30 kg (66 lbs) when mounted on Furio dolly, 57 kg (125 lbs) standalone or on a BlackBird
 - › Maximum pan/tilt speed: 90 degrees per second
 - › Net weight of head: 25 kg (55 lbs)
 - › Maximum teleprompter size: 50 cm (20")
 - › Encoders on the motors. Excellent for virtual set and augmented reality applications
 - **FRO-VR100-PT** (EOP) — Furio VR100 pan/tilt head, ideal for EFP/ENG cameras, box cameras with small lenses, and lightweight prompting systems.

Key Features and Specs:

- › Payload: up to 20 kg (44 lbs)
- › Maximum pan/tilt speed: 60 degrees per second
- › Net weight of head: 13.3 kg (29.3 lbs)
- › Maximum teleprompter size: 15" CueScript™ model CSEMC15.
- › Encoded pan and tilt axis. Suitable for virtual set and augmented reality applications

Furio Track-Mounted Dolly Packages (head, dolly, and optional robotic lift)

All Furio track-mounted dolly packages include a Furio SE robotic dolly. The dolly includes four auxiliary power outlets (IEC C13 female) for powering the camera and accessories.

The packages are as follows:

- **FRO-X350-ST-DLY-SE** — Furio X350 pan/tilt head mounted on a Furio SE robotic dolly. The head mounts to the dolly via a mounting adapter (included), or via a fixed-height column (optional accessory).
- **FRO-X350-ST-FULL-SE** — Furio X350 pan/tilt head atop a Furio SE three-stage robotic lift, all mounted on a Furio SE robotic dolly. The lift stroke is 85 cm (33").
- **FRO-X350-ST-FULL-S2** — Furio X350 pan/tilt head atop an S2 two-stage robotic lift, all mounted on a Furio SE robotic dolly. The lift stroke is 48.3 cm (19").
- **FRO-VR600-ST-DLY-SE** — Furio VR600 pan/tilt head on a track-mounted Furio SE robotic dolly. The head mounts directly to the dolly via a mounting adapter (included), or via a fixed-height column (optional accessory).
- **FRO-VR600-ST-FULL-SE** — Furio VR600 pan/tilt head atop a Furio SE three-stage robotic lift, all on a track-mounted Furio SE robotic dolly. The lift stroke is 85cm (33").
- **FRO-VR600-ST-FULL-S2** — Furio VR600 pan/tilt head atop an S2 two-stage robotic lift, all on a track-mounted Furio SE robotic dolly. The lift stroke is 50.8cm (19").
- **FRO-VR100-ST-DLY-SE (EOP)** — Furio VR100 pan/tilt head on a track-mounted Furio SE robotic dolly. The head mounts directly to the dolly via a mounting adapter (included), or via a fixed-height column (optional accessory).
- **FRO-VR100-ST-FULL-SE (EOP)** — Furio VR100 pan/tilt head atop a Furio SE three-stage robotic lift, all on a track-mounted Furio SE robotic dolly. The lift stroke is 85cm (33").
- **FRO-VR100-ST-FULL-S2 (EOP)** — Furio VR100 pan/tilt head atop an S2 two-stage robotic lift, all on a track-mounted Furio SE robotic dolly. The lift stroke is 50.8cm (19").

Furio Manual Pedestal Packages (head, robotic lift, and manual pedestal)

All Furio manual pedestal packages include a BlackBird S-Series manual pedestal. The pedestal features three smooth-rolling dual locking casters with integrated cable guards. It features a broad, ultra-stable base with unique anti-tip features, and can still roll through openings as narrow as 81.3cm (32"). Special alignment features in the base enable the BlackBird pedestal to be accurately repositioned around the studio floor.

The Furio manual pedestal packages are as follows:

- **FRO-X350-PTL-SE** — Furio X350 pan/tilt head atop a SE three-stage robotic lift, all on a BlackBird S-Series manual pedestal. The lift stroke is 88.7 cm (35").
- **FRO-X350-PTL-S2** — Furio X350 pan/tilt head atop a S2 two-stage robotic lift, all on a BlackBird S-Series manual pedestal. The lift stroke is 48.3 cm (19").
- **FRO-VR600-PTL-SE** — Furio VR600 pan/tilt head atop a Furio SE three-stage robotic lift, all on a BlackBird S-Series manual pedestal. The lift stroke is 85 cm (33").
- **FRO-VR600-PTL-S2** — Furio VR600 pan/tilt head atop a S2 two-stage robotic lift, all on a BlackBird S-Series manual pedestal. The lift stroke is 48.3 cm (19").

- **FRO-VR100-PTL-SE** — Furio VR100 pan/tilt head atop a Furio SE three-stage robotic lift, all on a BlackBird S-Series manual pedestal. The lift stroke is 85 cm (33”).
- **FRO-VR100-PTL-S2** — Furio VR100 pan/tilt head atop an S2 two-stage robotic lift all on a BlackBird S-Series manual pedestal. The lift stroke is 48.3 cm (19”).

Furio Accessories

The Furio product line features a wide range of optional accessories, including the following:

- **Remote Emergency Stop Modules** — An optional accessory for Furio SE robotic dollies, SkyDolly, BlackBird S-Series manual pedestals, and X350 heads. The remote emergency stop module enables an operator to remotely stop the robot to which the module is connected. Each module comes with a 20 m (65.6') cable that connects the module to a single dolly or pedestal. Other available cable lengths include: 30 m (98.4'), 40 m (131.2'), and 50 m (164').
- **Ethernet-based Collision Avoidance** — Starting with **SmartShell 7.0a**, the legacy FRO-CA Collision Avoidance System has been replaced by an Ethernet-based Collision Avoidance feature, which is now included by default. Unlike the Controller Area Network (CAN) based Collision Avoidance, the Ethernet-based system requires no hardware accessories or extra cables. Up to two dollies are supported on a track for Ethernet-Based Collision Avoidance. The Ethernet-based system allows robotic dollies to exchange positional data and automatically manage their movement to prevent collisions. For more information on setting up and utilizing the Ethernet-based Collision Avoidance, consult with our Program Managers and see the latest **Furio Collision Avoidance Setup Guide For Two Dollies (5100DR-309-XX)**.
- **Collision Avoidance System (Legacy)** — The Collision Avoidance System, now considered a legacy accessory as of SmartShell 7.0a, enabled up to four Furio SE robotic dollies to operate on a single track without risk of colliding. To protect two dollies, one FRO-CA kit was required. For three dollies, two FRO-CA kits were required. For four dollies, three FRO-CA kits were required. No more than four dollies could occupy a single track. Each kit included one collision avoidance module and associated cables. The system allowed the robotic dollies to exchange positional data. If necessary, the dollies automatically limited their movement to prevent collisions. Collision avoidance required additional cabling and conformance to specific track layout requirements. For more information about designing your layout to include collision avoidance, consult with our Program Managers and see the **Furio Collision Avoidance System Setup Guide (5100DR-012-XX)**.
- **Spare Parts Kits** — You can order spare parts kits to have readily available in case quick repairs are required.
- **Fixed-Height Columns** — These columns attach a Furio robotic head to a dolly or to a solid surface. Available heights are as follows:
 - › 30 cm (12”) — FRO-FCO-12
 - › 76 cm (30”) — FRO-FCO-30
 - › 122 cm (48”) — FRO-FCO-48
- **Universal Ceiling Mount** — This mount (FRO-UNI-CLM) clamps onto a section of lighting grid pipe, and is suitable for inverted mounting of the VR100 or VR600 head. The mount is designed to accept nominal 1.5” Schedule 40 pipe, which has an outside diameter of 1.9” (48 mm). The pipe outside diameter must be minimum 48 mm (1.9”), maximum 51 mm (2”). The mount can be attached to a single pipe, or to two pipes of a section of lighting truss. If mounted to a single pipe, the pipe must be well secured to prevent pipe rotation and other movement. If spanning two pipes of a lighting truss, the two pipes must be no more than 36 cm (14.15”) apart, center to center. The pipe or truss must be capable of supporting the weight of the robot, payload, and cables (plus appropriate safety factor).
- **Tripods and Pedestals** — Ross Video sells a variety of Cartoni tripods and pedestals suitable for mounting our robotic pan/tilt heads.
- **Mitchell Mount Adapter** — Ross Video produces a Mitchell mount adapter suitable for mounting any of our robotic pan/tilt heads.
- **CueScript™ Prompters** — Ross Video sells CueScript™ teleprompters that are fully compatible with our robots.



About Payload Design

It is important to plan exactly what components will be installed on the robot(s), and how they will be secured.

For best results, ensure that

- The payload is as light as possible. Lighter payloads result in smoother movement, especially when using a dolly. When determining the weight of the payload, remember to account for the weight of all cables that run to the head.
- The payload is as compact as possible and its weight is concentrated near its center. The payload must be balanced in two axes; front to back along the camera cradle, and vertically around the tilt axis.
- The prompter and talent monitor, if used, are light and small. They must be mounted rigidly to prevent unwanted movement of the robotic head. They must have no loose or free-moving parts. If a talent monitor is used on a dolly system, it must be mounted on the dolly using a Talent Monitor Mounting Bracket (FRO-TM-BRK).

General Studio Requirements

Robotics equipment must be installed in a suitable physical environment:

- Equipment must be installed in an indoor location not exposed to moisture.
- Acceptable air temperature range is 0°C to 40°C (32°F to 104°F).
- Acceptable air humidity range is 0% to 90% RH, non-condensing.
- For dolly systems, the mounting surface must be hard, flat, and inflexible. It must accept screws for track installation.



Power and Networking Requirements

The following table lists power and networking requirements for Furio robots:

Furio Robot System	Power and Networking Requirements
<p>FRO-X350-PT</p> <ul style="list-style-type: none"> • X350 pan/tilt head only 	<p>IMPORTANT: All cables that run to a robot or to a robotic head must contain stranded conductors only. Solid conductors are not acceptable because they are more likely to deteriorate due to robotic movement, causing intermittent data transmission. It is also important to use very light, flexible cables to reduce drag.</p>
<p>FRO-VR600-PT</p> <ul style="list-style-type: none"> • VR600 pan/tilt head only 	<p>Studio requirements are as follows:</p> <ul style="list-style-type: none"> • One AC power supply socket per head.
<p>FRO-VR100-PT</p> <ul style="list-style-type: none"> • VR100 pan/tilt head only 	<p>For X350 — Each head comes with a power supply unit that accepts voltages between 100V AC and 240V AC. Total power consumption per X350 head is 210 Watts, based on the default head configuration.</p> <p>For VR600 — Each head comes with a power supply unit that accepts voltages between 90VAC and 250V AC. Total power consumption per VR600 head is 33 Watts, based on the default head configuration. Custom high-performance configurations may consume more power. For more information, contact Ross Video.</p> <p>Note: The power supply circuit must be protected by a 15 A fuse or circuit breaker (for 120V AC circuits), or an 8A fuse or circuit breaker (for 240V AC circuits).</p> <p>For VR100 — Each head comes with a power supply unit that accepts voltages between 100V AC and 240V AC. Total power consumption per VR100 head is 22 Watts, based on the default head configuration.</p>
	<p>Custom high-performance configurations may consume more power. For more information, contact Ross Video.</p>
	<p>Each head comes with a 1.8 m (6') AC line cord with a suitable male plug for the country where the system is to be installed.</p>
	<ul style="list-style-type: none"> • One Ethernet connection per head on the VR100 and VR600. <p>The Ethernet cable must be stranded CAT5E, and the end that plugs into the head must terminate in a male RJ45 connector.</p>
	<p>The maximum cable distance between the head and the dedicated Ethernet network switch in the control room is 100 m (328'). This range can be increased using an Ethernet extender (not provided).</p>
	<ul style="list-style-type: none"> • One sync reference cable per head, terminating in a male standard BNC plug, which connects to a female standard BNC socket on the head. This is required only for AR/VS (Augmented Reality and/or Virtual Set) applications.
	<p>AR/VS applications require that the same sync reference signal be delivered to each robot, to each camera, and to the AR/VS graphics rendering system.</p>
	<ul style="list-style-type: none"> • Camera and accessory cables as required, including power cables, video cables, etc.

Furio Robot System	Power and Networking Requirements
<p>FRO-X350-DLY-SE</p> <ul style="list-style-type: none"> • X350 pan/tilt head • Furio SE robotic dolly 	<p>Studio requirements are as follows:</p> <ul style="list-style-type: none"> • One AC power supply cable per dolly, long enough to accommodate the full range of dolly movement.
<p>FRO-VR600-DLY-SE</p> <ul style="list-style-type: none"> • VR600 pan/tilt head • Furio SE robotic dolly 	<p>The dolly end of the cable must terminate in a C13 female socket connector (IEC/EN 60320-1), which plugs into a C14 male plug connector on the dolly's integrated power bar.</p> <p>The dolly accepts voltages between 90V AC and 250V AC. Total power consumption per robot is 700 Watts (without lift) or 1300 Watts (with lift). These values are for the robot only, and do not include power for cameras or accessories.</p>
<p>FRO-VR100-DLY-SE</p> <ul style="list-style-type: none"> • VR100 pan/tilt head • Furio SE robotic dolly 	<p>The power supply circuit must be protected by a 15A fuse or circuit breaker (for 120V AC circuits), or an 8A fuse or circuit breaker (for 240V AC circuits).</p> <ul style="list-style-type: none"> • One stranded CAT5E Ethernet network cable per robot, long enough to accommodate the full range of dolly/lift/head movement. One end of the cable connects to the robotics Ethernet network. The other end must terminate in a male RJ45 plug, which connects to a female RJ45 jack on the head.
<p>FRO-X350-FULL-SE</p> <ul style="list-style-type: none"> • X350 pan/tilt head • Furio SE three-stage robotic lift • Furio SE robotic dolly 	<p>The maximum cable distance between the head and a dedicated Ethernet network switch is 100 m (328'). This range can be increased using an Ethernet extender (not provided).</p> <ul style="list-style-type: none"> • One sync reference cable per head, terminating in a standard male BNC plug, which connects to a standard female BNC socket on the head. This is required only for AR/VS (Augmented Reality and/or Virtual Set) applications.
<p>FRO-VR600-FULL-SE</p> <ul style="list-style-type: none"> • VR600 pan/tilt head • Furio SE three-stage robotic lift • Furio SE robotic dolly 	<p>AR/VS applications require that the same sync reference signal be delivered to each robot, to each camera, and to the AR/VS graphics rendering system.</p> <ul style="list-style-type: none"> • Camera and accessory cables as required, including power cables, video cables, etc. All cables must be long enough to accommodate the full range of dolly/lift/head movement.
<p>FRO-X350-FULL-S2</p> <ul style="list-style-type: none"> • X350 pan/tilt head • S2 two-stage robotic lift • Furio SE robotic dolly 	<p>One end of the dolly has an integrated power bar with five female C13 socket connectors (IEC/EN 60320-1). One socket is for powering the dolly (power cable is included). The remaining four sockets are available for powering the camera and accessories.</p> <p>Ensure that all equipment plugged into the integrated power bar can accept the same AC voltage supplied to the dolly. Ensure that the total power load, including the robot, camera, and all accessories, does not exceed the supply circuit capacity.</p>
<p>FRO-VR600-FULL-S2</p> <ul style="list-style-type: none"> • VR600 pan/tilt head • S2 two-stage robotic lift • Furio SE robotic dolly 	<p>The dolly comes with an assortment of male/female C14/C13 cables that can be used to power the camera and accessories.</p> <p>The dolly motor and lift (if equipped) are powered directly through the dolly without additional power cables. A special power cable is included for connecting the head to the dolly. This cable can be used with an X350, VR600, or VR100.</p>
<p>FRO-VR100-FULL-S2</p> <ul style="list-style-type: none"> • VR100 pan/tilt head • S2 two-stage robotic lift • Furio SE robotic dolly 	<p>For more information, see "Dolly Travel Range" on page 11.</p>

Furio Robot System	Power and Networking Requirements
<p>FRO-X350-PTL-SE</p> <ul style="list-style-type: none"> • X350 pan/tilt head • Furio SE three-stage robotic lift <p>BlackBird S-Series manual pedestal</p>	<p>IMPORTANT: All cables that run to a robot or to a robotic head must contain stranded conductors only. Solid conductors are not acceptable because they are more likely to deteriorate due to robotic movement, causing intermittent data transmission. It is also important to use very light, flexible cables to reduce drag.</p> <p>Studio requirements are as follows:</p> <ul style="list-style-type: none"> • One AC power supply cable per robot, long enough to allow repositioning of the pedestal. The robot end of the cable must terminate in a C13 female socket connector (IEC/EN 60320-1), which plugs into a C14 male plug connector on the pedestal base. The pedestal accepts voltages between 90VAC and 250VAC. Total power consumption per robot is 700 Watts, including head and lift. These values are for the robot only, and do not include power for cameras or accessories. The power supply circuit must be protected by a 15 A fuse or circuit breaker (for 120V AC circuits), or an 8 A fuse or circuit breaker (for 240V AC circuits). • One CAT5E Ethernet network cable per robot, long enough to accommodate the full range of pedestal movement. One end of the cable connects to the robotics Ethernet network. The other end must terminate in a male RJ45 plug, which connects to a female RJ45 jack on the head. The maximum cable distance between the head and a dedicated Ethernet network switch is 100m (328'). This range can be increased using an Ethernet extender (not provided). • One sync reference cable per head, terminating in a standard male BNC plug, which connects to a standard female BNC socket on the head. This is required only for AR/VS (Augmented Reality and/or Virtual Set) applications. AR/VS applications require that the same sync reference signal be delivered to each robot, to each camera, and to the AR/VS graphics rendering system. • Camera and accessory cables as required, including power cables, video cables, etc. All cables must be long enough to accommodate the full range of dolly/lift/head movement. The lift motor is powered directly through the pedestal without additional power cables. A special power cable is included for connecting the head to the base. This cable can be used with a VR100 head or a VR600 head. A flexible sleeve (cable sock) is included to wrap the bundle of cables that runs between the pedestal base and the head.
<p>FRO-VR600-PTL-SE</p> <ul style="list-style-type: none"> • VR600 pan/tilt head • Furio SE three-stage robotic lift <p>BlackBird S-Series manual pedestal</p>	
<p>FRO-VR100-PTL-SE</p> <ul style="list-style-type: none"> • VR100 pan/tilt head • Furio SE three-stage robotic lift • BlackBird S-Series manual pedestal 	
<p>FRO-X350-PTL-S2</p> <ul style="list-style-type: none"> • X350 pan/tilt head • S2 two-stage robotic lift • BlackBird S-Series manual pedestal 	
<p>FRO-VR600-PTL-S2</p> <ul style="list-style-type: none"> • VR600 pan/tilt head • S2 two-stage robotic lift • BlackBird S-Series manual pedestal 	
<p>FRO-VR100-PTL-S2</p> <ul style="list-style-type: none"> • VR100 pan/tilt head • S2 two-stage robotic lift • BlackBird S-Series manual pedestal 	

Studio Floor Requirements

- For systems that include a BlackBird S-Series manual pedestal, the studio floor must be free of ramps and sudden changes in floor height.
- The pedestal is fitted with anti-tip outriggers for increased stability and these may catch the floor when moving over an uneven surface. This problem can often be avoided by rotating the pedestal and moving over the feature in a different orientation. The clearance height of the outriggers on a flat surface is approximately 3/8" (10mm).
- The maximum potential applied pressure is 3000 psi (20 MPa).

Note: This includes static and dynamic loads from acceleration and 3 m radius rails.

Note: Ross Video does not provide Ethernet cables, power supply cables, sync reference cables, or video cables. Such cables are selected or custom-made to suit the facility, and are to be provided by the systems integrator or the customer. We strongly suggest you consult with our Program Managers to plan your cabling layout.

Accommodating Furio Tracks and Furio SE Robotic Dollies

Furio SE robotic dollies mounted on tracks enable you to execute complex, visually-stunning moving shots. The repeatability of the shots enables you to create a signature visual style for each show.

To get the best results from your Furio SE robotic dolly system, we recommend you plan the track layout as part of your set design process.

We want to help! Ross Video is pleased to provide guidance and answer any questions you might have about planning your installation. Our friendly, experienced Program Managers can help you achieve an efficient and trouble-free installation.

This section describes some things to consider when designing your set and Furio track layout:

- **"Track Geometry"** on **page 9**
- **"Dolly Travel Range"** on **page 11**
- **"Barcode Positioning System (BPS)"** on **page 11**
- **"Track End Bumpers"** on **page 12**
- **"Mounting Surface"** on **page 13**
- **"Accessibility for Maintenance"** on **page 13**
- **"Traffic and Sightlines"** on **page 13**
- **"Cable Management"** on **page 13**

Track Geometry

Furio tracks are delivered as track sections that must be joined together to create the track.

The assembled track can be straight, curved, or mixed. S-shaped tracks are only supported when using the BPS track sensor; they cannot be used with legacy wiredraw sensors.

Note: If your system includes a legacy Furio Collision Avoidance System, additional cabling and conformance to specific track layout requirements is necessary. For more information about designing your layout to include collision avoidance, consult with our Program Managers and see the **Furio Collision Avoidance Setup Guide (5100DR-012-xx)**.

Straight track sections come in standard length of 2 m (78.7"). Custom-length sections are also available.

Curved track is specified by nominal track radius and degrees of a circle. Nominal track radius is measured from the center of a circle to the center of the outside rail. For example, you can order a curved track with a 10 m nominal track radius, comprising 45 degrees of a circle. Unless the curved portion of the track is shorter than 3 m (118"), it consists of multiple track sections.

Track width is 39.5 cm (15.6"). The dolly and accessories extend beyond the track width. For dimensioned drawings of Furio dollies, lifts, and head(s), contact Ross Video.

Contact Ross Video for CAD drawings of your track sections.

Track sections are fastened to the mounting surface by screws. The screws extend through the traverses (cross-members) that join the two rails of the track section together (see **Figure 1 -**). Each traverse has one mounting hole. Each track section has three traverses: one at the center plus one close to each end (approximately 5 to 8 cm (2 to 3") from the center of the traverse to the end of the track).

The riser must support the full length of the track, not just the traverses.

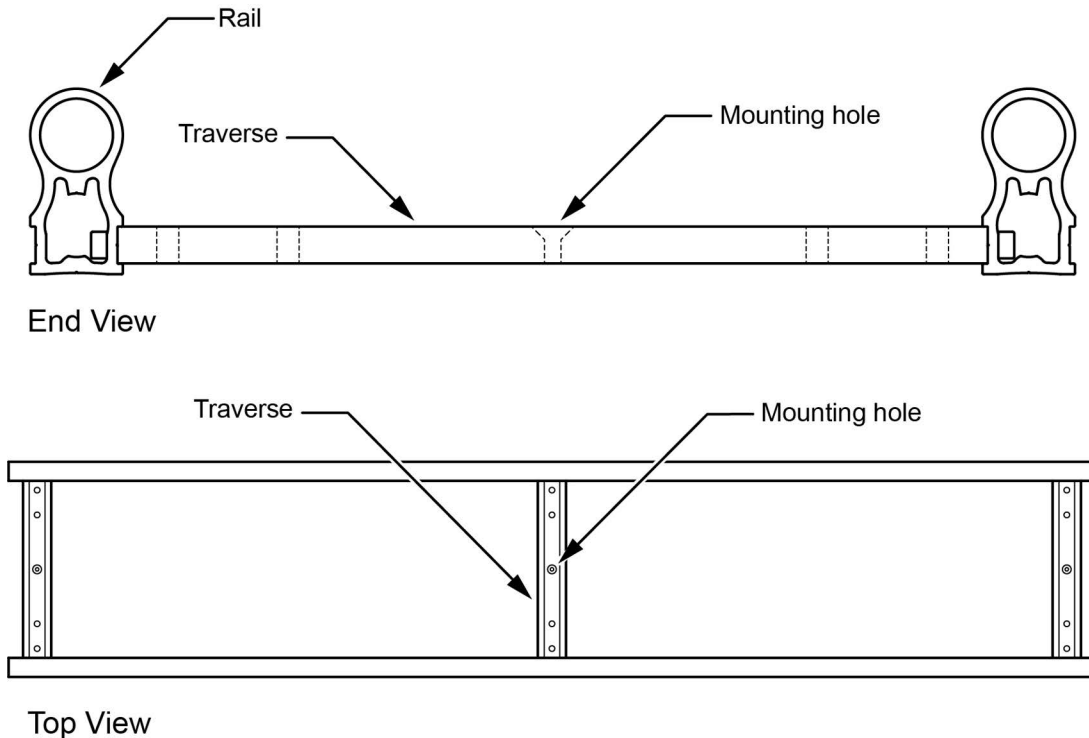

Figure 1 - - Track Section End View (top), and Top View (bottom). Drawings are not to scale.

Note: If you plan to deploy multiple dollies on a single track, we strongly recommend you implement an Ethernet-Based Collision Avoidance system. For more information about designing your layout to include collision avoidance, consult with our Program Managers and see the **Furio Collision Avoidance System Setup Guide For Two Dollies (5100DR-309-01)**.

Track Geometry Limitations When Operating with AR/VS Applications

Minimum Length Requirement

In AR/VS applications, each continuous curved segment, whether it consists of a single track piece or multiple adjacent sections of the same radius, must have an inner rail length at least equal to the dolly wheelbase. For floor dollies, the wheelbase is 500 mm.

The minimum curve angle that meets this requirement is:

Track Radius	Minimum Curve Angle
2.6 m	12.82°
3.0 m	10.9°



The minimum curve angle can be calculated using the following generalized formula:

$$\text{arcLengthInDegrees} = 2 \times \arcsin\left(\frac{500}{2 \times (\text{nominalTrackRadiusInMm} - 360)}\right)$$

Placement of Curves with Different Radii

In AR/VS applications, adjacent curved sections may now have different radii, provided each section (or group of same-radius sections) individually satisfies the minimum inner-rail length condition above. There is no longer a requirement to insert a straight section between curves of different radii.

However, if curved sections are not directly adjacent (i.e., separated by a straight run), that straight segment must still be longer than the dolly's 500 mm wheelbase.

AR/VS Tracking

On a perfect track, the accuracy of the reported virtual position of a dolly on a U-shaped track with a 3 m radius is ± 2 mm of XY virtual position error and ± 0.15 degrees of virtual orientation (pan) error.

Any error or non-linearity in the radius or the alignment of the tracks will have a significant effect on this.

For example:

- Each 1 mm error in the measured radius of a U-shaped track with a 3 m radius can result in up to 5 mm of virtual position error and 0.05 degrees of virtual pan error
- Each 1 mm of rail elevation difference contributes 6.2 mm of virtual position error perpendicular to the track direction when the SE lift is at full extension (2228 mm). A VR600 head is assumed in this calculation.

Barcode Positioning System (BPS)

The Barcode Positioning System (BPS) replaces traditional wiredraw encoders in all Furio Studio models effective July 2024. This transition enhances the precision, reliability, and maintenance of the system.

Key Specifications

- **Accuracy:** Submillimeter positioning accuracy from 0 to 10,000 meters.
- **Speed:** Control at traverse rates up to 5 millimeters per second.
- **Measurement:** Simultaneous position and speed measurement.
- **Track Layout Flexibility:** Supports straight, curved, mixed-radius, and S-shaped track geometries.

Environmental Requirements

- **Humidity:** 0% to 90% relative humidity, non-condensing.
- **Lighting:** Avoid direct exposure to intense, direct lighting; ensure consistent lighting conditions.
- **Cleanliness:** Maintain a clean environment; regular cleaning of barcode tape and sensors with a soft cloth and commercial glass cleaner.

Installation and Mounting

When mounting the BPS unit and installing barcode tape:

- Ensure barcode tape is free of wrinkles and mechanical tension.
- Barcode tapes are available in the following lengths:



- › 10 meters (Product Code FRO-BPS-TAPE-10)
- › 20 meters (Product Code FRO-BPS-TAPE-20)
- › 30 meters (Product Code FRO-BPS-TAPE-30)
- › 40 meters (Product Code FRO-BPS-TAPE-40)
- › 50 meters (Product Code FRO-BPS-TAPE-50)
- › 70 meters (Product Code FRO-BPS-TAPE-70)

Embedded Rail BPS Requirements

For studios using embedded rail configurations with the BPS, the following spatial and alignment requirements must be met to ensure proper functionality:

- Maximum floor height above the rail base: 52.5 mm
- Height of embedded rail exposed above the finished floor: 17.5 mm
- Minimum gap between the inside floor panel and the side of the rail: 16 mm

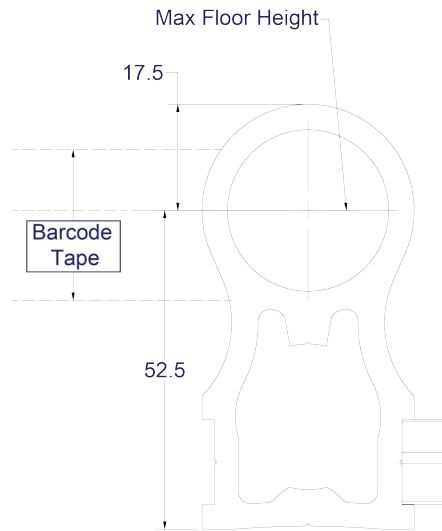

Note: Laser beams are projected at slight downward angles toward the tape and require an unobstructed line of sight at all times.

Note: Barcode tape location is the same for all floor Furio installations and is installed on the same side as the drive wheel.

Maintenance

Routine checks include:

- Regularly inspect barcode tape for wear or damage.
- Clean optical sensors and barcode tape to ensure accurate readings.
- Perform firmware updates as needed via Ross Video customer service.

Track End Bumpers

A pair of spring-loaded bumpers are installed at each end of the track to cushion impact and help prevent damage to equipment. Bumpers are a last-resort measure for stopping the dolly. Software limits and a laser/reflector system are designed to prevent the dolly from reaching the bumpers. The bumpers act as a physical stop in the event that the software limits have been set incorrectly or the reflectors have not been properly installed.

Note: For systems with legacy wiredraw units, an end of the track does not have a wiredraw enclosure, allow 20 cm (8") of extra space for an end bumper unit. If an end of the track has a wiredraw enclosure, the bumper hardware mounts onto the wiredraw enclosure base.

Mounting Surface

Furio tracks must be mounted on a solid, flat, level, inflexible surface that can accept screws. The mounting surface must be free of any rough portions that might inhibit track installation. Providing a suitable mounting surface is the responsibility of the customer.

Ideally, the rails should be installed directly on structural concrete to eliminate any possibility of flex or deformation under the load of the dolly. If mounted to some other surface or structure, it must be designed such that there is no measurable flex under load, which can be as much as 3000 psi (20 MPa). This includes both static and dynamic loads from acceleration on a 3 m radius section of curved rail.

When tracks are installed, they are carefully leveled using shims, and then permanently fastened in place, using Loctite to ensure the fasteners cannot come loose. The tracks must be installed perfectly level. If the tracks are not level, the dolly may wobble and cause the camera to shake, or the dolly may lean and cause inaccurate positional data for AR/VS applications, or the motorized wheels of the dolly may lose traction.

Typical track mounting surfaces, in order of preference:

1. **Studio floor** — A flat, level, concrete studio floor makes an excellent mounting surface. Tracks are fastened to the floor by screws, so penetrating the floor surface must be allowed.
2. **Welded steel-frame risers** — Steel-frame risers with all sections firmly welded together can provide an excellent mounting surface. Steel framing should be positioned close to track traverses to completely eliminate flexing. The design must minimize vibration and noise.
3. **Extruded aluminum risers** — Risers made of extruded aluminum members joined by hardware can produce a good mounting surface. Aluminum structural members should be positioned close to track traverses to completely eliminate flexing. The design must minimize vibration and noise.
4. **Wooden risers** — This is the least-favorable option. If wooden risers must be used, they must be as rigid and flat as possible. Structural members must be spaced closely enough to completely eliminate deflection of the riser surface. Track traverses should be positioned directly over structural members to ensure solid fastening. We recommend that hollow risers be filled with sand or other vibration-absorbing material to reduce vibration and noise as much as possible.

Accessibility for Maintenance

Furio tracks, dollies, cables, and other components occasionally require preventive and corrective maintenance. Your set design must allow full access to all system components.

Traffic and Sightlines

For safety, we strongly recommend the following:

- If possible, people should not walk over the track or cables. The track and cables may present a tripping hazard, and people crossing the track may be at risk of being struck by a moving dolly.
- The operator should have an unobstructed view of the entire track. Closed-circuit video cameras can be installed to provide an unobstructed view.

Cable Management

As each dolly travels along the track, it drags a cable bundle behind it. Excessive cable weight or surface friction can impair smooth movement of the dolly along the track. Interference with other cable bundles can also cause problems.

Typically, cables are encased in a cable sock which keeps them together and reduces friction. In some applications, a plastic cable chain (IGUS chain) may be used. For more information about using a cable chain as part of your system, contact Ross Video.

IMPORTANT: We strongly suggest you consult with the Ross Video Program Management Team before committing to a cable management plan. Our friendly, experienced Program Managers can help you achieve an efficient and trouble-free installation.

To ensure that cable bundles move smoothly:

- Reduce the number and size of cables as much as possible.
- Use very flexible (stranded conductor) cables only.
- Design the spaces where the cable bundles travel:
 - › The surface must be smooth and low-friction.
 - › The cable spaces should either allow the cable bundles to move freely, or guide the cable bundles so they move and coil predictably. Your design can include barriers to guide the cable bundles.
 - › The cable bundles must not be allowed to climb onto the track.
 - › People must be kept away from the cable bundles when they are moving. Barriers can guide the cable bundles and discourage people from crossing over the cable space(s) and the track.

Note: If your system includes a legacy Furio Collision Avoidance System, your set design must accommodate the collision avoidance module(s) and associated data cables. Depending on the track length and configuration, these data cables may or may not be included in the dolly cable bundles. For more information about designing your layout to include collision avoidance, consult with our Program Managers and see the ***Furio Collision Avoidance Setup Guide (5100DR-012-XX)***.

Furio Cable Guard

The Furio Cable Guard is a 12.7 cm / 5" high aluminum barrier that keeps cable bundles off the track. For curved tracks, it runs along the outside edge of the curve. For best results, install cable guard along the full length of the track.

Available Cable Guard kits include:

- FRO-GRD-START (starter kit) – this kit includes a variety of panel lengths to allow one to tailor the overall length of cable guard to match the length of track without requiring customized panels. Can cover track lengths ranging from 2.5 m / 8' 4" to 4.1 m / 13' 7".
- FRO-GRD-2M (extension kit) – single 2 m section of cable guard.