

# Furio Passive Wheel Replacement for Dollies with StableTrac

## Introduction

This document describes how to replace passive wheels on your Furio dolly system.

The replacement process requires **two people** at minimum and takes approximately **1 hour** per dolly (approximately twenty minutes per wheel unit).

**CAUTION:** Ensure the dolly is **OFF** before starting the wheel replacement process.

## Before You Begin

The Furio dolly has four wheel units; one drive wheel unit (with motor and cables attached), and three passive wheel units. This document describes how to replace a passive wheel unit.

The passive wheel sets on the **fixed side** of the dolly are unique from the passive wheel set on the **StableTrac side**. The instructions that follow provide information on how to access and replace all wheels on both sides of the dolly. Refer to **Figure 1**.

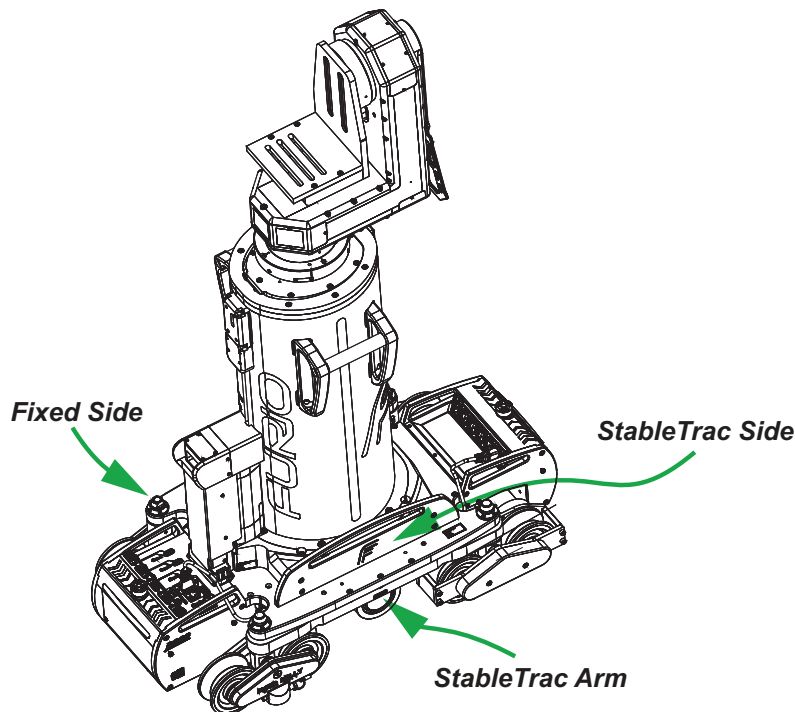
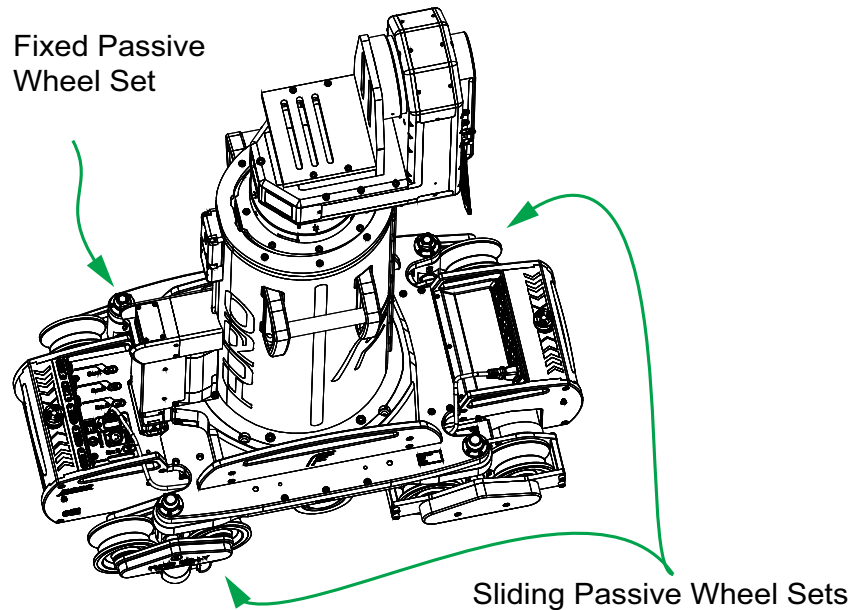

**Figure 1** - Fixed and StableTrac Sides of the Furio Dolly

Ensure you install the correct passive wheels on each side. Before you begin, read and understand all instructions. If you have any questions, contact **Ross Video Technical Support**: [techsupport@rossvideo.com](mailto:techsupport@rossvideo.com).

## Passive Wheel Unit Types

If you removed multiple wheel units, determine where each is to be reinstalled. There are two types of passive wheel units on the fixed side; the fixed shaft and the sliding shaft. The fixed shaft wheel unit must be installed diagonally opposite to the drive wheel unit.



**Figure 2 - Sliding Passive Wheel Sets and Fixed Passive Wheel Set**

## Wheel Replacement Contents

The following items are provided within the **Passive Wheel Replacement Kit (FRO-SP-WHPAS-ST-U)**:

- Six wheels
- One 2.5 mm hexagonal wrench
- Two 5 mm hexagonal wrenches
- One 6 mm hexagonal wrench
- Three 5ml tubes of Loctite® 243 Threadlocker adhesive

## Required Tools

The following tools are required to replace Furio passive wheels:

- One 17 mm open-end wrench
- Two large slot screwdrivers
- One wooden prop block approximately 5-1/2" x 5-1/2" x 7" (140 mm x 140 mm x 180 mm).

## Procedure Overview

The instructions for this replacement procedure include:

1. **"Removing the Stability Wheels" on page 4**
2. **"Preparing the Dolly for Wheel Replacement" on page 5**
3. **"Removing the Sliding Passive Wheel Units on the Fixed Side of the Dolly" on page 6**
4. **"Replacing the Sliding Passive Wheels on the Fixed Side of the Dolly" on page 8**
5. **"Reinstalling the Sliding Passive Wheel Units on the Fixed Side of the Dolly" on page 9**
6. **"Tip: If the nut spins without tightening, insert a 5 mm hexagonal wrench into the locking hole in the side of the shaft below the base plate. The tool locks the shaft as you turn the wrench, so you can tighten the nut." on page 9**
7. **"Removing the Fixed Passive Wheel Unit on the Fixed Side of the Dolly" on page 10**
8. **"Replacing the Fixed Passive Wheels on the Fixed Side of the Dolly" on page 11**
9. **"Reinstalling the Fixed Passive Wheel Units on the Fixed Side of the Dolly" on page 11**
10. **"Removing the Sliding Passive Wheel Units on the StableTrac Side of the Dolly" on page 12**
11. **"Replacing the Passive Wheels on the StableTrac Side of the dolly" on page 13**
12. **"Reinstalling the Passive Wheel Units on the StableTrac Side" on page 14**
13. **"Reattaching the Stability Wheels" on page 16**
14. **"Restoring Dolly Power and Connectivity" on page 16**

## Removing the Stability Wheels

There are two sliding passive wheel sets on the dolly, each containing stability wheels, which ensure the wheels are securely fixed to the track. Refer to **Figure 3**.

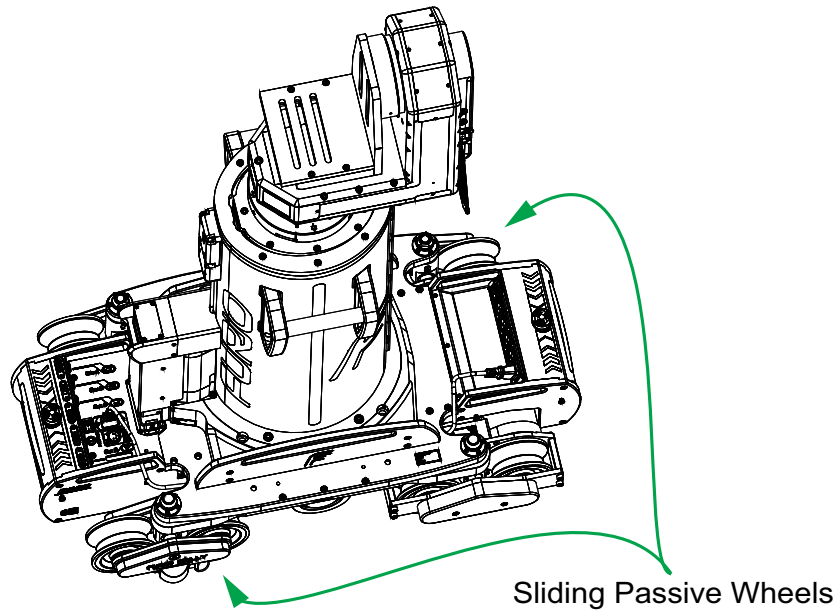

**Figure 3 - Sliding Passive Wheels with Stability Wheels**

Removing these wheels allows the dolly to be lifted from the track.

### Remove the Stability Wheels

For the two sliding passive wheel sets, complete the following:

1. Locate the stability wheel.
2. Remove the locking pin by pressing and holding the pin lock button while sliding the locking pin out. Refer to **Figure 4**.
3. Remove the stability wheel.

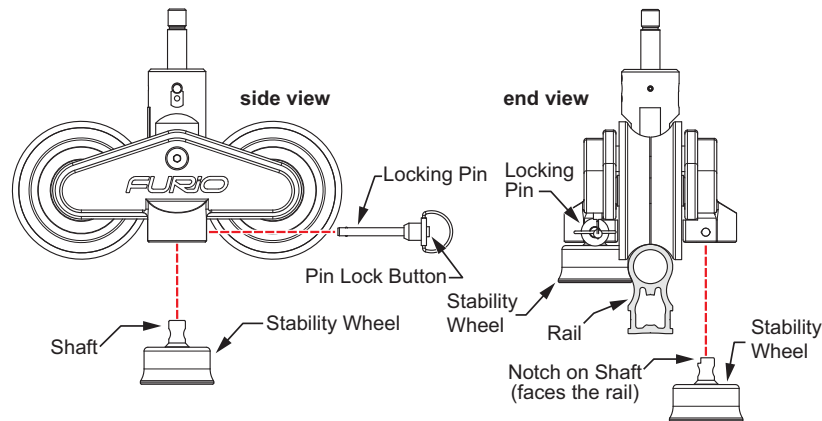

**Figure 4 - Removing Stability Wheels**

## Preparing the Dolly for Wheel Replacement

The following instructions demonstrate the necessary steps to prepare the dolly for wheel replacement.

### Prepare the Dolly for Wheel Replacement

1. Move the dolly to where there is plenty of working space, ideally above a straight track and close to the wiredraw enclosure. Ensure the end with the drive wheel set is between traverses (cross pieces), so nothing is between the bottom of the dolly and the floor.
2. Lower the lift column, disconnect the power cable to the head, turn off power to the dolly, and disconnect the dolly power cable.
3. Detach the wiredraw cable from the dolly with the 6 mm hexagonal wrench and hold it.

**Note:** Grasp the cable end tightly, but do not wrap it around your hand or bend it.

**CAUTION:** Handle the wiredraw cable with care to avoid permanently damaging the cable and wiredraw unit. Never allow the cable to snap back into the wiredraw unit. If you release the cable and it snaps back into the wiredraw unit, the unit may be irreparably damaged.

4. Hold the cable close to the floor and parallel to the track to avoid rubbing the steel cable against the wiredraw enclosure box, protecting the cable from damage.
5. Slowly walk the cable back to the wiredraw unit. Do not allow it to snag or rub against anything, except the part of the rail it normally contacts (curved tracks only).

**IMPORTANT:** Do not allow the cable to snap back to the wiredraw enclosure!

6. Have one or two people lift and hold up the end of the dolly by the dolly base handles while another places a wooden prop block underneath the dolly's IEC Module. Refer to **Figure 5**.

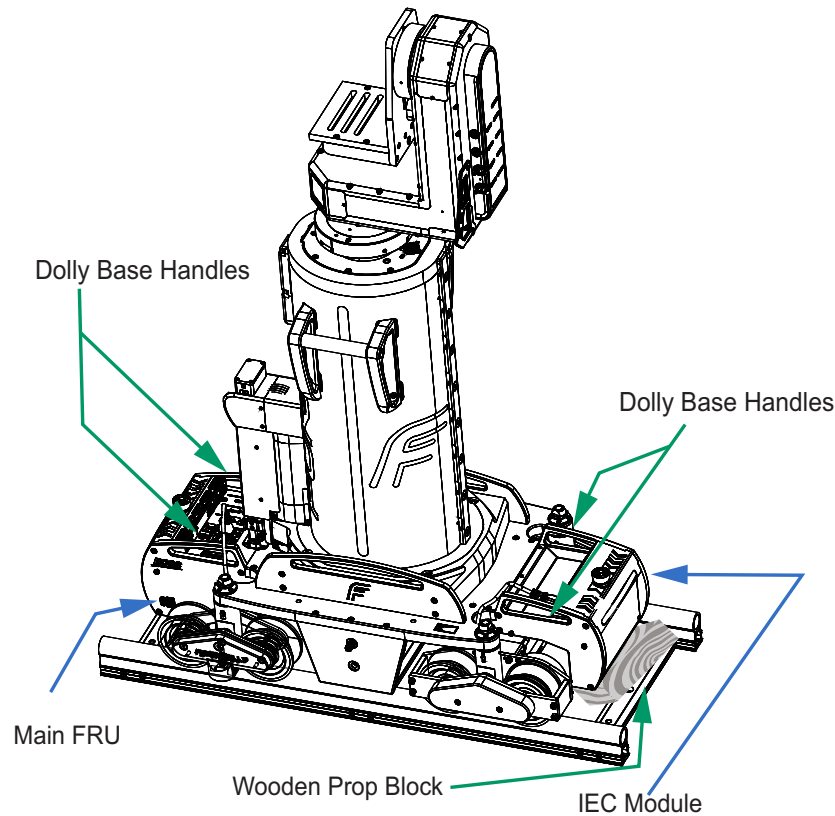

**Figure 5 - Dolly Handles and Wooden Prop Block under the IEC Module**

**IMPORTANT:** Lift only by the dolly base handles shown in the illustration. Never lift the payload or the top section of the lift column. Improper lifting may damage the payload and/or dolly. Follow workplace safety rules and do not tip or drop the dolly.

**IMPORTANT:** Do not attempt to disconnect the motor cables between the drive wheel set and the dolly. Do not pull the cables taut. Damage to the cables may result.

## Removing the Sliding Passive Wheel Units on the Fixed Side of the Dolly

The passive wheel sets on the fixed side of the dolly must be detached from the dolly base to replace the wheels. If you are only replacing the passive wheel set on the StableTrac side of the dolly, skip to **“Remove the Sliding Passive Wheel Units on the StableTrac Side of the dolly”** on **page 12**.

## Remove the Sliding Passive Wheel Units on the Fixed Side of the Dolly

1. Use a 17 mm open-end wrench to remove the nut above the sliding passive wheel units on the fixed side of the dolly. Refer to **Figure 6**.

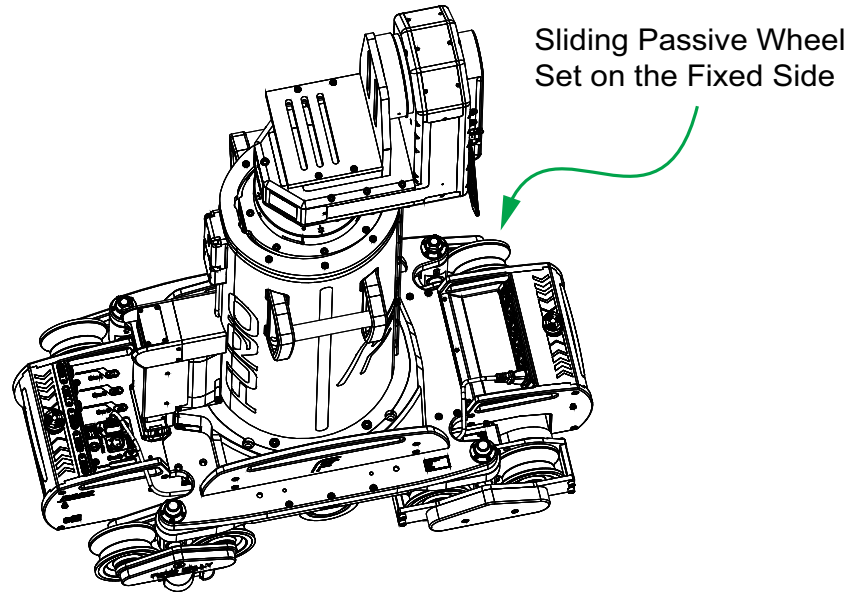

**Figure 6** - Sliding Passive Wheel Set on the Fixed Side of the Dolly

**Tip:** If the nut spins without coming off, insert a 5 mm hexagonal wrench into the locking hole in the side of the shaft. The tool locks the shaft as you turn the wrench, enabling you to remove the nut.

2. Have one or two people lift and hold up the end of the dolly by the handles while another removes the sliding passive wheel units and sets it aside.

**IMPORTANT:** Lift only by the lift points shown in the illustration. Never lift the payload or the top section of the lift column! Improper lifting may damage the payload and/or dolly.

**IMPORTANT:** The dolly is heavy. Get help, and follow workplace safety rules. Be careful not to tip or drop the dolly.

**Tip:** Remove only one wheel unit at a time to ensure you reinstall them in their original positions. There are two types of passive wheel units, and they must be reinstalled in the correct positions.

## Replacing the Sliding Passive Wheels on the Fixed Side of the Dolly

The wheels are secured behind a wheel plate within the wheel unit. The following instructions provide steps on how to access and replace the individual wheels.

### Replace the Sliding Passive Wheels on the Fixed Side of the Dolly

Each passive wheel unit consists of two wheels and a shaft, sandwiched between two plates. The wheel unit is held together by two screws that attach the plates to the shaft. Removing one screw and the associated plate allows access to both wheels.

1. Using two 5 mm hexagonal wrenches in opposition to each other, remove one of the screws that holds the wheel unit together. Refer to **Figure 7**.

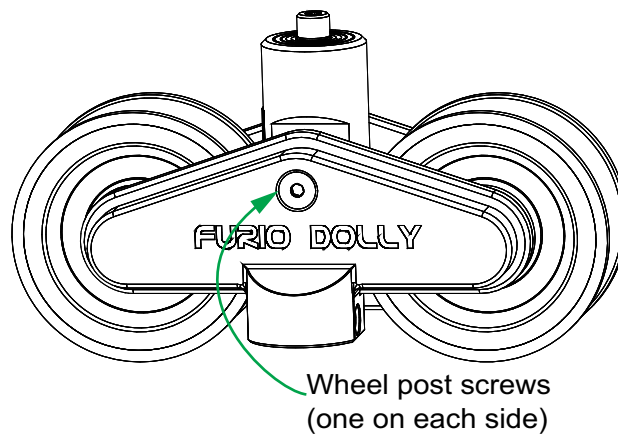

**Figure 7** - Removing the Passive Wheel Post Screws

**Tip:** The screws are secured with thread-locking adhesive. As you turn both wrenches counter-clockwise, one of the screws will come loose. Remove that screw, and leave the other one in place.

2. Remove the wheel plate covering the wheel set.
3. Remove both wheels and replace them with new ones.
4. Reinstall the wheel plate screws from **Step 1**, ensuring that the wheel axles are properly seated in the axle holes of both plates.
5. Open a new bottle of Loctite® 243 Threadlocker adhesive and apply a few drops of it to the threaded portion of the screw.
6. Insert the screw and then, using two 5 mm hexagonal wrenches in opposition to each other, tighten the screws.

## Reinstalling the Sliding Passive Wheel Units on the Fixed Side of the Dolly

The passive wheels have now been added to their respective sliding passive wheel set. In the instructions that follow, you'll secure the sliding passive wheel units to the dolly base.

### Reinstall the Sliding Passive Wheel Units on the Fixed Side of the Dolly

1. Have one or two people lift and hold up the end of the dolly by the handles, while another attaches the sliding wheel unit by sliding its vertical shaft through the hole in the dolly base and loosely attaching the nut.
 

**IMPORTANT:** Lift only by the lift points shown in the illustration. Never lift the payload or the top section of the lift column. Improper lifting may damage the payload and/or dolly.

**IMPORTANT:** The dolly is heavy. Get help, and follow workplace safety rules. Be careful not to tip or drop the dolly.
2. Use the 17mm open-end wrench to tighten the nut at the top of the vertical shaft.
 

**Tip:** If the nut spins without tightening, insert a 5 mm hexagonal wrench into the locking hole in the side of the shaft below the base plate. The tool locks the shaft as you turn the wrench, so you can tighten the nut.

## Moving the Prop Block

The following instructions demonstrate the necessary steps to prepare the dolly for wheel replacement. The prop block must be moved to the opposite end of the dolly to finish the passive wheel installation process.

### Move the Prop Block

1. Have one or two people lift and hold up the end of the dolly by the dolly base handles.
2. Have one person remove the wooden prop block from underneath the dolly's IEC Module and transfer it under the Main FRU. Refer to **Figure 8**.

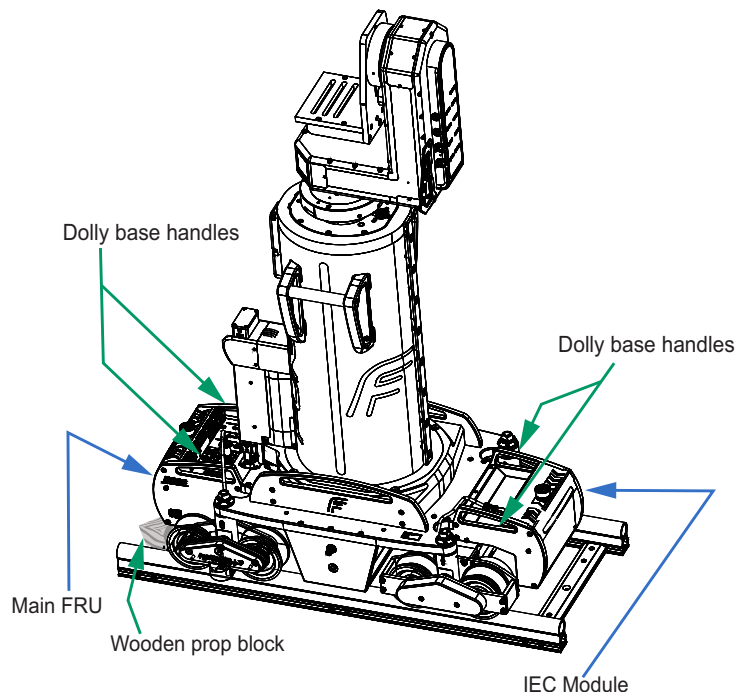

**Figure 8 - Moving the Wooden Prop Block under the Main FRU**

## Removing the Fixed Passive Wheel Unit on the Fixed Side of the Dolly

The passive wheel sets on the fixed side of the dolly must be detached from the dolly base to replace the wheels. Both the fixed passive wheel set on the fixed side of the dolly and the sliding passive wheel set on the StableTrac side of the dolly require the prop block to be moved under the Main FRU.

### Remove the Fixed Passive Wheel on the Fixed Side of the Dolly

1. Use a 17mm open-end wrench to remove the nut above the fixed passive wheel unit on the fixed side of the dolly. Refer to **Figure 9**.

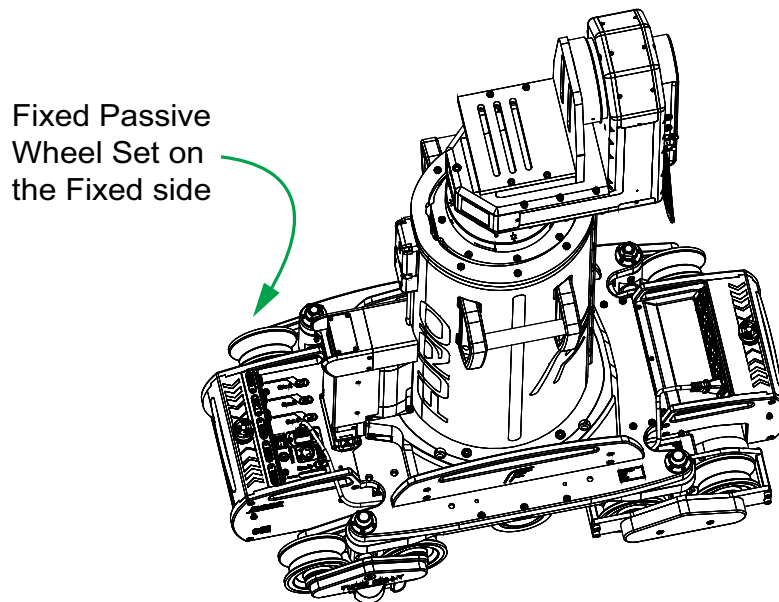

**Figure 9** - Fixed Passive Wheel Set on the Fixed Side of the Dolly

**Tip:** If the nut spins without coming off, insert a 5 mm hexagonal wrench into the locking hole in the side of the shaft. The tool locks the shaft as you turn the wrench, enabling you to remove the nut.

2. Have one or two people lift and hold up the end of the dolly by the handles while another removes the fixed passive wheel unit and sets it aside.

**IMPORTANT:** Lift only by the lift points shown in the illustration. Never lift the payload or the top section of the lift column! Improper lifting may damage the payload and/or dolly.

**IMPORTANT:** The dolly is heavy. Get help, and follow workplace safety rules. Be careful not to tip or drop the dolly.

**Tip:** Remove only one wheel unit at a time to ensure you reinstall them in their original positions. There are two types of passive wheel units, and they must be reinstalled in the correct positions.

## Replacing the Fixed Passive Wheels on the Fixed Side of the Dolly

The following instructions provide steps on how to access and replace the individual wheels.

### Replace the Fixed Passive Wheels on the Fixed Side of the Dolly

Each passive wheel unit consists of two wheels and a shaft, sandwiched between two plates. The wheel unit is held together by two screws that attach the plates to the shaft. Removing one screw and the associated plate allows access to both wheels.

1. Using two 5 mm hexagonal wrenches in opposition to each other, remove one of the screws that holds the wheel unit together. Refer to **Figure 10**.

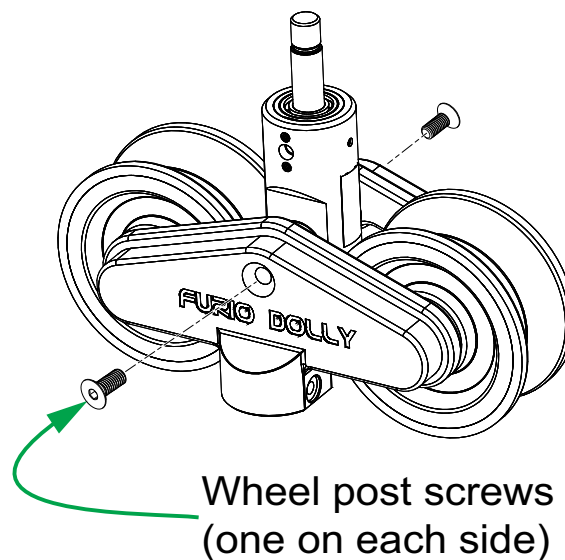

**Figure 10** - Removing the Passive Wheel Post Screws

Tip: The screws are secured with thread-locking adhesive. As you turn both wrenches counter-clockwise, one of the screws will come loose. Remove that screw, and leave the other one in place.

2. Remove the wheel plate covering the wheel set.
3. Remove both wheels and replace them with new ones.
4. Reinstall the wheel plate screws from Step 1, ensuring that the wheel axles are properly seated in the axle holes of both plates.
5. Open a new bottle of Loctite® 243 Threadlocker adhesive and apply a few drops of it to the threaded portion of the screw.
6. Insert the screw and then, using two 5mm hexagonal wrenches in opposition to each other, tighten the screws.

## Reinstalling the Fixed Passive Wheel Units on the Fixed Side of the Dolly

In the instructions that follow, you'll secure the fixed passive wheel unit to the dolly base.

## Reinstall the Fixed Passive Wheel Unit on the Fixed Side of the Dolly

1. Have one or two people lift and hold up the end of the dolly by the handles, while another attaches the fixed wheel unit by sliding its vertical shaft through the hole in the dolly base and loosely attaching the nut.

**IMPORTANT:** Lift only by the lift points shown in the illustration. Never lift the payload or the top section of the lift column. Improper lifting may damage the payload and/or dolly.

**IMPORTANT:** The dolly is heavy. Get help, and follow workplace safety rules. Be careful not to tip or drop the dolly.

2. Use the 17mm open-end wrench to tighten the nut at the top of the vertical shaft.

**Tip:** If the nut spins without tightening, insert a 5 mm hexagonal wrench into the locking hole in the side of the shaft below the base plate. The tool locks the shaft as you turn the wrench, so you can tighten the nut.

## Removing the Sliding Passive Wheel Units on the StableTrac Side of the Dolly

The passive wheel sets on the StableTrac side of the dolly must be detached from the dolly base to replace the wheels. This section provides instructions on how to isolate the passive wheel set from the dolly base.

### Remove the Sliding Passive Wheel Units on the StableTrac Side of the dolly

1. Have one or two people lift and hold up the end of the dolly by the handles while another removes the sliding passive wheel unit on the StableTrac side and sets it aside. Refer to **Figure 12**.

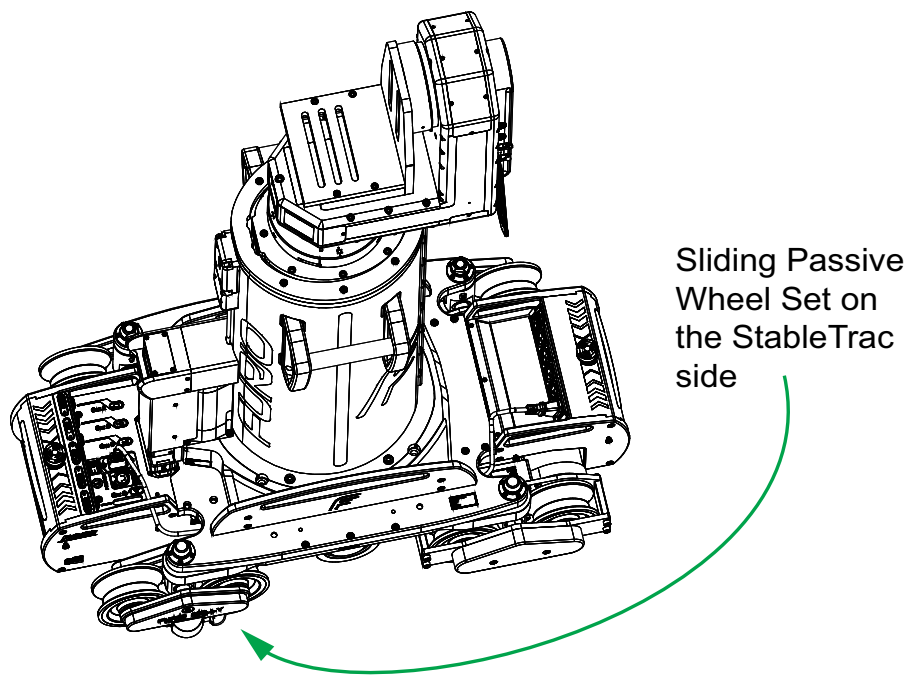
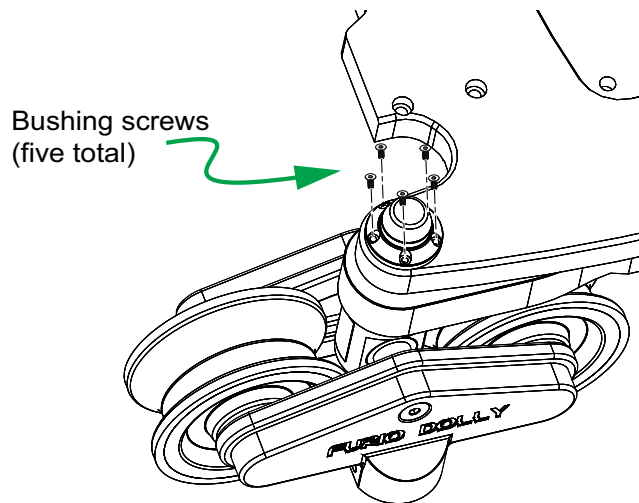

**Figure 11** - Sliding Passive Wheel set on the StableTrac Side of the Dolly

**IMPORTANT:** Lift only by the lift points shown in the illustration. Never lift the payload or the top section of the lift column! Improper lifting may damage the payload and/or dolly.

**IMPORTANT:** The dolly is heavy. Get help, and follow workplace safety rules. Be careful not to tip or drop the dolly.

2. Use a 2.5 mm hexagonal wrench to remove the five screws securing the passive wheel bushing to the dolly base. Refer to **Figure 12**.



**Figure 12** - Removing the Passive Wheel Bushing on the StableTrac Side

**Note:** Turn the hexagonal wrench clockwise to loosen the drive wheel set.

3. Remove the passive wheel bushing.
4. Use the 6 mm hexagonal wrench to unscrew the vertical wheel post from the StableTrac arm.

**Note:** There is no fixed orientation for passive wheel attachment. The sides are functionally interchangeable.

## Replacing the Passive Wheels on the StableTrac Side of the dolly

The passive wheel post height and bushing are unique on the StableTrac side of the dolly. Replacing passive wheels on this side requires a distinct process than on the fixed side.

### Replace the Passive Wheels on the StableTrac Side of the Dolly

Follow these instructions to replace the passive wheels on the StableTrac side.

- Using two 5 mm hexagonal wrenches in opposition to each other, remove the screws that hold the wheel unit together. Refer to **Figure 13**.

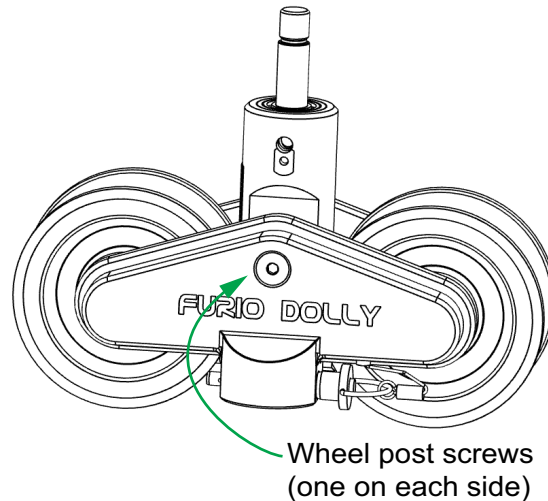

**Figure 13** - Removing the Passive Wheel Post Screws

**Tip:** The screws are secured with thread-locking adhesive. As you turn both wrenches counter-clockwise, one of the screws will come loose. Remove that screw, and leave the other one in place.

- Remove the wheel plate covering the wheel set.
- Remove both wheels and replace them with new ones.
- Reinstall the inner plate passive wheel screws from **Step 1**, ensuring that the wheel axles are properly seated in the axle holes of both plates.
- Open a new bottle of Loctite® 243 Threadlocker adhesive and apply a few drops of it to the threaded portion of the screw.
- Insert the screw and then, using two 5 mm hexagonal wrenches in opposition to each other, tighten the screws.

## Reinstalling the Passive Wheel Units on the StableTrac Side

The passive wheels have now been added to their respective wheel unit. In the instructions that follow, you'll secure the passive wheel units to the dolly base.

### Reinstall the Passive Wheel Units on the StableTrac Side

- Have one or two people lift and hold up the end of the dolly by the handles, while another attaches the wheel units by sliding its vertical shaft through the hole in the dolly base and loosely attaching the nut.

**IMPORTANT:** Lift only by the lift points shown in the illustration. Never lift the payload or the top section of the lift column. Improper lifting may damage the payload and/or dolly.

**IMPORTANT:** The dolly is heavy. Get help, and follow workplace safety rules. Be careful not to tip or drop the dolly.

- Remove the wooden prop block, and then gently lower the dolly onto the track. Ensure all wheels are properly seated on the track.
- Use a 6 mm hexagonal wrench to screw the vertical wheel post to the StableTrac arm.

**Note:** There is no fixed orientation for passive wheel attachment. The sides are functionally interchangeable.

4. Attach the passive wheel bushing.
5. Use a 2.5 mm hexagonal wrench to secure the 5 passive wheel bushing screws to the dolly base. Refer to **Figure 14**.

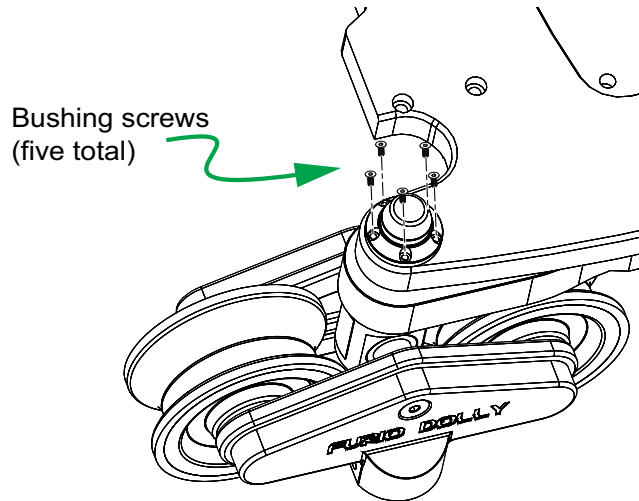

**Figure 14** - Removing the Passive Wheel Bushing on the StableTrac Side

## Reattaching the Stability Wheels

With the passive wheel set successfully installed and the dolly secured on the track, you can now reattach the stability wheels. Note that only the two sliding passive wheels have stability wheels. Refer to **Figure 3**.

### Attach the Stability Wheels

For both of the sliding passive wheel sets, complete the following:

1. Insert the shaft of the stability wheel into its hole.
2. Rotate the stability wheel shaft so the notch on the shaft faces the drive wheel set.
3. Pull and hold the pin lock button, then slide the locking pin into its hole. Refer to **Figure 15**.

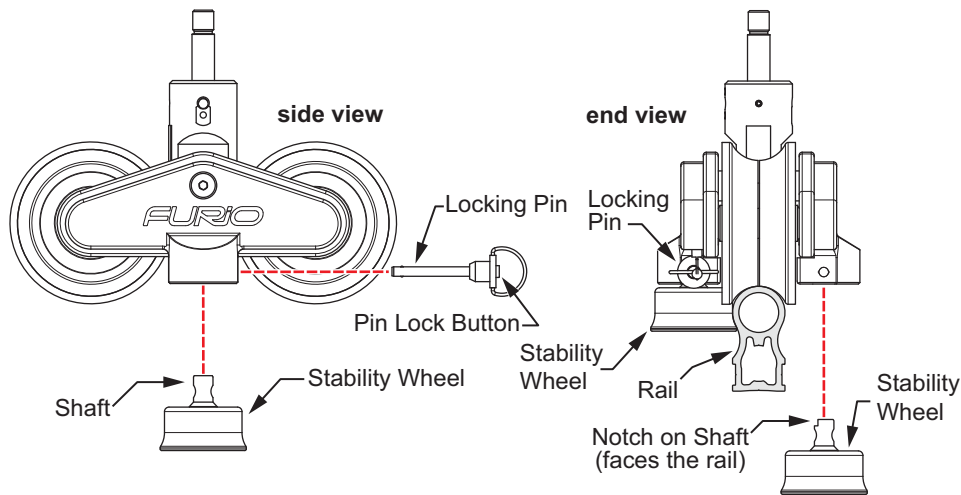

**Figure 15 - Attaching Stability Wheels**

## Restoring Dolly Power and Connectivity

The passive wheel set installation process is complete. In this final process, restore the dolly's power and ensure all parts are functioning properly, as outlined below.

### Restore Dolly Power and Connectivity

1. Obtain the wiredraw cable from the wiredraw unit and hold it.

**Note:** Grasp the cable end tightly, but do not wrap it around your hand or bend it.

**IMPORTANT:** Handle the wiredraw cable with care to avoid permanently damaging the cable and wiredraw unit. NEVER allow the cable to snap back into the wiredraw unit. If you release the cable and it snaps back into the wiredraw unit, the unit may be irreparably damaged.

2. Hold the cable close to the floor and parallel to the track to avoid rubbing of the steel cable against the wiredraw enclosure box, protecting the cable from damage.
3. Slowly feed the cable into the wiredraw mount. Do not allow it to snag or rub against anything, except the part of the rail it normally contacts (curved tracks only).
4. Use 6 mm hexagonal wrench and associated bolt to attach wire draw to the bracket.
5. Reconnect the power cable to the dolly and the head.
6. Turn the dolly on, and test that it travels smoothly.

**Note:** Listen to ensure there is no rubbing noise. If there is, the belt is not properly installed.