



Furio Collision Avoidance System

Setup Guide

Thank You for Choosing Ross

You've made a great choice. We expect you will be very happy with your purchase of Ross Technology.

Our mission is to:

1. Provide a Superior Customer Experience
 - offer the best product quality and support
2. Make Cool Practical Technology
 - develop great products that customers love

Ross has become well known for the Ross Video Code of Ethics. It guides our interactions and empowers our employees. I hope you enjoy reading it below.

If anything at all with your Ross experience does not live up to your expectations be sure to reach out to us at solutions@rossvideo.com.



David Ross
CEO, Ross Video
dross@rossvideo.com

Ross Video Code of Ethics

Any company is the sum total of the people that make things happen. At Ross, our employees are a special group. Our employees truly care about doing a great job and delivering a high quality customer experience every day. This code of ethics hangs on the wall of all Ross Video locations to guide our behavior:

1. We will always act in our customers' best interest.
2. We will do our best to understand our customers' requirements.
3. We will not ship crap.
4. We will be great to work with.
5. We will do something extra for our customers, as an apology, when something big goes wrong and it's our fault.
6. We will keep our promises.
7. We will treat the competition with respect.
8. We will cooperate with and help other friendly companies.
9. We will go above and beyond in times of crisis. *If there's no one to authorize the required action in times of company or customer crisis - do what you know in your heart is right. (You may rent helicopters if necessary.)*

Furio Collision Avoidance System Setup Guide

- Ross Part Number: 5100DR-012-03
- Publication Date: April 12, 2019. Printed in Canada.

Copyright

©2019 Ross Video Limited, Ross®, and any related marks are trademarks or registered trademarks of Ross Video Limited. All other trademarks are the property of their respective companies. PATENTS ISSUED and PENDING. All rights reserved. No part of this publication may be reproduced, stored in a retrieval system, or transmitted in any form or by any means, mechanical, photocopying, recording or otherwise, without the prior written permission of Ross Video. While every precaution has been taken in the preparation of this document, Ross Video assumes no responsibility for errors or omissions. Neither is any liability assumed for damages resulting from the use of the information contained herein.

Patents

Ross Video products are protected by patent numbers US 7,034,886; US 7,508,455; US 7,602,446; US 7,802,802 B2; US 7,834,886; US 7,914,332; US 8,307,284; US 8,407,374 B2; US 8,499,019 B2; US 8,519,949 B2; US 8,743,292 B2; GB 2,419,119 B; GB 2,447,380 B. Other patents pending.

Company Address



Ross Video Limited

8 John Street
Iroquois, Ontario
Canada, K0E 1K0

Ross Video Incorporated

P.O. Box 880
Ogdensburg, New York
USA 13669-0880

General Business Office: (+1) 613 • 652 • 4886

Fax: (+1) 613 • 652 • 4425

Toll Free Technical Support: 1-844-652-0645 (North America)

+800 1005 0100 (International)

Technical Support: (+1) 613 • 652 • 4886

After Hours Emergency: (+1) 613 • 349 • 0006

E-mail (Technical Support): techsupport@rossvideo.com

E-mail (General Information): solutions@rossvideo.com

Website: <http://www.rossvideo.com>

Contents

| | |
|--|-----------|
| Introduction | 7 |
| About This Guide | 7 |
| Documentation Conventions | 7 |
| Contacting Technical Support | 8 |
| The Collision Avoidance System | 9 |
| The Collision Avoidance Module | 9 |
| Routine Maintenance and Cleaning | 10 |
| Hardware Installation | 11 |
| Designing the Track Layout to Accommodate Collision Avoidance | 11 |
| Set Up and Test the Furio Dolly System Without Collision Avoidance | 12 |
| Designate One End of the Track as the Primary End | 12 |
| Position and Cable the Collision Avoidance Modules | 12 |
| Test Data Connectivity | 21 |
| Dress the Data Cables | 21 |
| Mount the Collision Avoidance Module(s) | 21 |
| Configuration | 25 |
| Calculate Parameter Values | 25 |
| Edit the Configuration Template File | 28 |
| Calibrate to a Common Reference Point At the Center of the Track | 35 |
| Set Track Axis Limits | 36 |
| Test Collision Avoidance Behavior | 36 |

Introduction

Thank you for choosing Ross Video!

About This Guide

This is the Setup Guide for the Furio Collision Avoidance System. The collision avoidance system is an optional accessory that prevents multiple Furio robotic dollies on a single track from colliding. The system enables the dollies to exchange data about their positions. The dollies are configured to slow down and/or stop moving if they are in danger of colliding.

This Setup Guide describes the collision avoidance system. It includes the following chapters:

- Chapter 1, “**Introduction**” on page 1–7, introduces the guide and provides information about documentation conventions and how to contact Ross Video Technical Support.
- Chapter 2, “**The Collision Avoidance System**” on page 2–9, introduces the collision avoidance module.
- Chapter 3, “**Hardware Installation**” on page 3–11, describes how to install the hardware components of the collision avoidance system.
- Chapter 4, “**Configuration**” on page 4–25, describes how to configure and test the collision avoidance system.

Documentation Conventions

Special text formats are used in this guide to identify parts of the user interface, text that a user must enter, or a sequence of menus and submenus that must be followed to reach a particular command.

Interface Elements

Bold text is used to identify a user interface element such as a dialog box, menu item, or button. For example:

On the **Axis Settings** tab, in the **Track_Encoder** section, click **Set Current**.

User Entered Text

Courier text is used to identify text that a user must type. For example:

In the address bar, type `localhost`, and then press **Enter**.

Referenced Guides

Italic text is used to identify the titles of referenced guides, manuals, or documents. For example:

For more information, refer to the *SmartShell User Guide (5100DR-002)*.

Menu Sequences

Menu arrows are used in procedures to identify a sequence of menu items that you must follow. For example, if a step reads “Click **Server** > **Save As**,” you would click the **Server** menu and then click **Save As**.

Contacting Technical Support

At Ross Video we take pride in the quality of our products, but if problems occur help is as close as the nearest telephone.

Our 24-hour Hot Line service ensures you have access to technical expertise around the clock. After-sales service and technical support is provided directly by Ross Video personnel. During business hours (Eastern Time), technical support personnel are available by telephone. After hours and on weekends, a direct emergency technical support phone line is available. If the technical support person who is on call does not answer this line immediately, a voice message can be left and the call will be returned shortly. This team of highly trained staff is available to react to any problem and to do whatever is necessary to ensure customer satisfaction.

- **Technical Support:** (+1) 613-652-4886
- **Toll Free Technical Support:** 1-844-652-0645 (North America), or +800 1005 0100 (International)
- **After Hours Emergency:** (+1) 613-349-0006
- **E-mail (Technical Support):** techsupport@rossvideo.com
- **E-mail (General Information):** solutions@rossvideo.com
- **Website:** <http://www.rossvideo.com>

The Collision Avoidance System

The Furio Collision Avoidance System is an optional accessory that prevents multiple Furio robotic dollies on a single track from colliding. The system enables the dollies to exchange data about their positions.

Each dolly is configured to slow down and/or stop moving if it is in danger of colliding with another dolly:

- If one dolly is moving towards a stationary dolly, it slows to a stop to avoid colliding.
- If two dollies are moving towards each other, both dollies will slow to a stop to avoid colliding.
- If two dollies are moving the same direction and they get too close, the faster dolly slows down to match the slower dolly's pace.
- If a dolly is performing a move or preset and the collision avoidance features slow or stop it, the move or preset resumes as soon as the way is clear. The dolly moves to the final position but because of the interruption, the move or preset may not perform exactly as expected. You can cancel the rest of the move or preset by stopping the camera system. For information about executing and stopping moves and presets, see the *SmartShell User Guide (5100DR-002)*.

Note: Setting up the Furio Collision Avoidance System involves installing hardware components and changing configuration settings on each dolly's robotic head. After you configure the heads for collision avoidance, all existing presets and moves are lost and cannot be restored.

The Collision Avoidance Module

The collision avoidance module is a device that enables Furio dollies to exchange information about their track positions. Each collision avoidance system includes one, two, or three collision avoidance modules.

Each dolly is connected by a thin metal cable to a dedicated wiredraw unit at the end of the track. The wiredraw unit transmits data about the dolly's track position to a collision avoidance module. If there are only two dollies, both are connected to a single collision avoidance module. If there are three or four dollies, one or two additional collision avoidance modules are required.

Configuration settings on the dolly heads enable you to customize the collision avoidance behavior for each dolly.



Figure 2.1 Furio Collision Avoidance Module

IMPORTANT: After you install and configure the collision avoidance module, you must test collision avoidance behavior to ensure the system is functioning as expected. You must also test collision avoidance behavior after any changes to the configuration of the robotic heads, and after any changes to the system hardware components. For information about testing collision avoidance behavior, see “**Test Collision Avoidance Behavior**” on page 4–36.

Contents of a Collision Module Package

The collision avoidance module comes in a package that includes everything you need to protect two Furio dollies. To protect three dollies, you need two collision avoidance module packages. For four dollies, you need three packages. The Ross Video ordering code for a collision avoidance module package is **FRO-CA**.

In addition to the collision avoidance module, the FRO-CA package includes the following:

- Two CAN bus data cables, 0.5 m (19”) long
- Two CAN bus data cables, 20 m (65’) long
- One self-adhesive rubber mounting pad
- One set of hook-and-loop mounting pads
- Four #8 screws
- Four #8 plastic anchors
- This Setup Guide

Routine Maintenance and Cleaning

The collision avoidance module requires no routine maintenance.

To clean the module, wipe it with a slightly damp rag. Do not get cable connectors wet.

IMPORTANT: The collision avoidance module is not waterproof or water resistant. Protect it from inclement weather, and do not immerse it in any liquid.

Hardware Installation

Your Furio layout consists of a track, up to four dollies, and wiredraw units at the end(s) of the track. Implementing the Furio Collision Avoidance System involves adding one or more collision avoidance modules and CAN network cables that run from the collision avoidance module(s) to the wiredraw units, and to the dollies.

This chapter describes track layout factors to consider when designing a system that includes collision avoidance. It also provides information and diagrams about how to install the hardware components of the Furio Collision Avoidance System.

IMPORTANT: Complete all installation procedures in the order in which this Setup Guide presents them.

Topics in this chapter include the following:

- “**Designing the Track Layout to Accommodate Collision Avoidance**” on page 3–11
- “**Set Up and Test the Furio Dolly System Without Collision Avoidance**” on page 3–12
- “**Designate One End of the Track as the Primary End**” on page 3–12
- “**Position and Cable the Collision Avoidance Modules**” on page 3–12
- “**Test Data Connectivity**” on page 3–21
- “**Dress the Data Cables**” on page 3–21
- “**Mount the Collision Avoidance Module(s)**” on page 3–21

IMPORTANT: The procedures in this section chapter assume the Furio dolly system is set up and fully operational. Power down all Furio robots and the control system before you install any collision avoidance system hardware components.

After you install the hardware components of the collision avoidance system, you must configure and test the system. For more information, see “**Configuration**” on page 4–25.

Designing the Track Layout to Accommodate Collision Avoidance

Track layout factors to consider when designing a system with collision avoidance include:

- **Shape of the track**

The shape of the track can be straight, curved, or mixed.

A mixed track has straight and curved portions. If a track has multiple curves, there must be a straight portion between them.

S-curves are not supported.

- **Length of the track**

Collision avoidance modules communicate with dollies and wiredraw units over a CAN network. Due to technical limitations of the CAN protocol, the maximum CAN data cable length between network nodes is 43 m (141'). Wiredraw units and pan/tilt heads are network nodes. Collision avoidance modules and dolly bases are not.

If the system includes multiple collision avoidance modules, they are co-located and are linked by 0.5 m (19") CAN data cables.

The FRO-CA package includes two 20 m (65') data cables and two 0.5 m (19") data cables. A 2 m (6' 6") cable shipped with the lift column runs from the dolly base to the pan/tilt head.

IMPORTANT: The track layout must be designed such that a 20 m (65') CAN data cable can reach from the collision avoidance module(s) to any dolly base or any wiredraw unit.

The longest data cable run is 42.5 m (140'), and occurs in systems with three or four dollies:

- A 20 m (65') data cable runs from the wiredraw unit at the end of the track to a collision avoidance module.
- A 0.5 m (19") data cable runs from that collision avoidance module to a second one.
- A 20 m (65') data cable runs from the second collision avoidance module to the dolly base.
- A 2 m (6' 6") data cable runs from the dolly base to the robotic pan/tilt head.

Tip: The length of a curved or mixed track is measured along the outside (long) edge of the track.

Set Up and Test the Furio Dolly System Without Collision Avoidance

Set up your Furio dolly system without collision avoidance and test it to ensure it is working properly.

WARNING: If the track length exceeds the capacity of the wiredraw encoder (15 m (49') or 30 m (98')) for one or more dollies, configure “hard” track limits on the robotic pan/tilt heads of affected dollies to make it impossible for them to reach the end of the wiredraw range. If a wiredraw cable is pulled all the way to the end, it will destroy the wiredraw encoder.

Tip: If you are installing a new Furio system, do not fully dress the cable bundles that run to the dollies, until after you install the collision avoidance system. Depending on your layout, data cables that run between the dollies and the collision avoidance module may need to be added to the bundles. Detailed procedures in this chapter include more information about this.

IMPORTANT: After you install and configure the collision avoidance module, you must test collision avoidance behavior to ensure the system is functioning as expected. You must also test collision avoidance behavior after any changes to the configuration of the robotic heads, and after any changes to the system hardware components. For information about testing collision avoidance behavior, see “**Test Collision Avoidance Behavior**” on page 4-36.

Designate One End of the Track as the Primary End

For the purpose of describing how to set up and configure the collision avoidance system, one end of the track is designated as the **primary** end. The other end is the **secondary** end. Procedures in this Setup Guide frequently refer to the primary and secondary ends of the track. It is important to designate the primary and secondary ends properly and to take them into consideration as required.

This section describes how to determine which end of the track is the primary end.

To select the primary end:

- If there are only two dollies and both wiredraw encoders are on the same end of the track, that end is the primary end.
- If each end has one or more wiredraw encoders, choose one end to be the primary end. This is an arbitrary decision.

Tip: After configuration, the track position value for a given dolly increases as it moves away from the primary end and toward the secondary end.

IMPORTANT: In this Setup Guide, the dolly closest to the primary end is referred to as **Dolly A**. The next dolly along the track is **Dolly B**, and so on. Knowing these letter designations is required during layout and configuration of the collision avoidance system.

Position and Cable the Collision Avoidance Modules

This section explains how to connect and disconnect CAN data cables, and illustrates supported collision avoidance layouts for two, three, and four-dolly systems.

Based on the information and layout diagrams in this section, position and cable the collision avoidance modules required to protect your Furio dollies.

Note: When determining where to install the collision avoidance module(s), be sure the location allows adequate space for connecting and disconnecting data cables. It must be a dry location where the collision avoidance module(s) will not be subject to physical damage. Ensure the mounting surface is flat, clean, and dry.

This section of the Setup Guide includes the following topics:

- “**Connecting and Disconnecting CAN Data Cables**” on page 3–13
- “**Collision Avoidance System Layout for Two Dollies**” on page 3–13
- “**Collision Avoidance System Layout for Three Dollies**” on page 3–15
- “**Collision Avoidance System Layout for Four Dollies**” on page 3–18

Note: After you install the hardware components, you must configure and test the system. For more information, see “**Configuration**” on page 4–25.

Connecting and Disconnecting CAN Data Cables

Each end of a CAN data cable has an orientation key that aligns with an orientation groove on the socket (**Figure 3.1**). To connect, rotate the connector until properly aligned, and then insert the connector into the socket. The connector clicks when fully inserted.

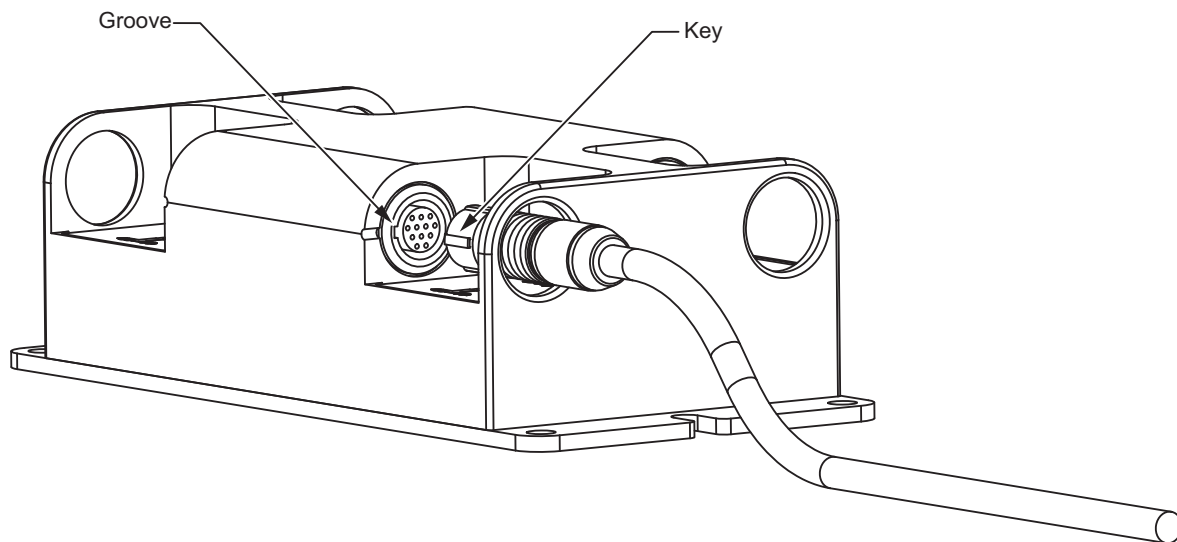

Figure 3.1 Cable connector and socket, showing orientation key and groove

To disconnect a CAN data cable, grip the connector close to the socket, and pull back gently.

IMPORTANT: Never pull on the cable! The cable connector is locked to the socket and the cable may rip apart if abused. If the system is powered when a cable fails in this manner, conductors may short circuit and destroy the collision avoidance module and/or other components.

Collision Avoidance System Layout for Two Dollies

This section describes supported layouts for two-dolly Furio systems. The layout varies based on the capacity of the wiredraw encoders:

- If each dolly has a 15 m (49') wiredraw encoder, the wiredraw units are typically installed in a single enclosure at one end of the track. The collision avoidance module is installed beside the wiredraw enclosure.

Each side of the collision avoidance module receives two data cables to support one dolly. One 0.5 m (19") data cable is from the dolly's wiredraw encoder, and the other data cable (20 m (65')) extends to the dolly base. An additional 2 m (6'6") data cable runs from the dolly base to the robotic pan/tilt head.

- If one or both of the dollies has a 30 m (98') wiredraw encoder, the wiredraw units are installed on opposite ends of the track. The collision avoidance module is installed somewhere between the two ends of the track. It must be within 20 m (65') cable distance of each wiredraw unit and each dolly. Be sure to account for the full range of track motion for both dollies.

Each side of the collision avoidance module receives two 20 m (65') data cables to support one dolly. One data cable is from the dolly's wiredraw encoder, and the other data cable extends to the dolly base. An additional 2 m (6' 6") data cable runs from the dolly base to the robotic pan/tilt head.

Tip: The FRO-CA kit contains two 20 m (65') CAN data cables. The other two data cables that you need are shipped with the dollies.

Connecting to the Collision Avoidance Module

The right side of the collision avoidance module supports **Dolly A**, which is the dolly closest to the **primary** end of the track.

The left side of the collision avoidance module supports **Dolly B**, which is the dolly closest to the **secondary** end of the track.

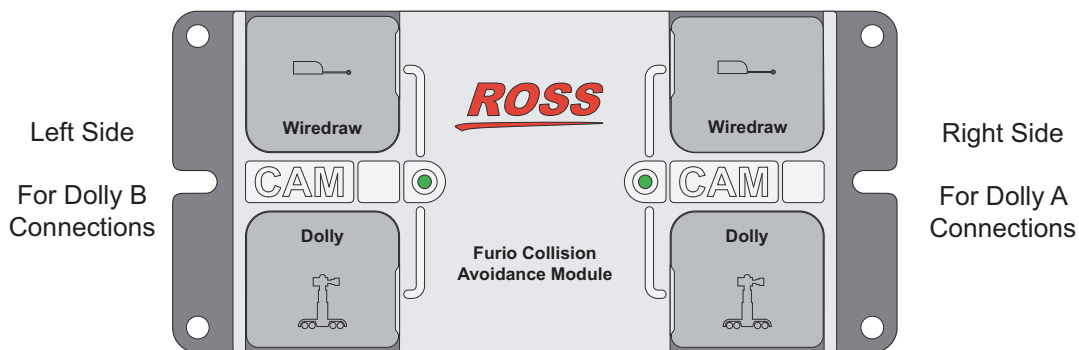

Figure 3.2 Right and Left sides of the Collision Avoidance Module

Tip: You can use a marker to label each side of the collision avoidance module, as shown in (Figure 3.3).



Figure 3.3 Labeling the Collision Avoidance Module

Collision Avoidance System Layout for Three Dollies

This section of the Setup Guide describes the supported layout for a three-dolly Furio system with collision avoidance.

When you connect CAN data cables to the collision avoidance modules, they must be connected exactly as shown. Other cable configurations may cause the collision avoidance system to fail.

This section of the Setup Guide refers to connection sockets on the collision avoidance modules, as shown in **Figure 3.4**.

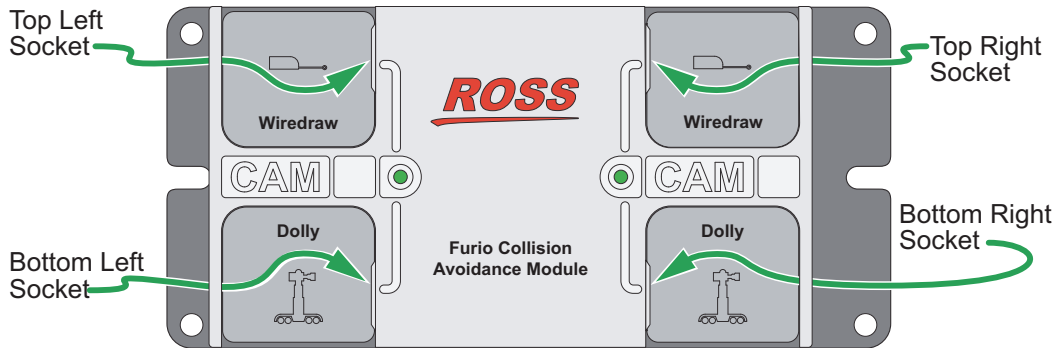

Figure 3.4 How This Section of the Setup Guide Refers to Connector Sockets on the Collision Avoidance Module

Three-dolly systems have two 15 m (49') wiredraw encoders at one end of the track, and either a 15 m (49') or a 30 m (98') wiredraw encoder at the other end. The two collision avoidance modules are installed somewhere between the two ends of the track. The modules are installed together, and must be within 20 m (65') cable distance of each wiredraw unit and each dolly. Be sure to account for the full range of track motion for all dollies

Figure 3.5 illustrates CAN data cable connections for a three-dolly system. The data cables must be connected exactly as shown. In **Figure 3.5**, the collision avoidance modules are labeled as **CA1** and **CA2**, and the camera systems (dollies) are labeled **A**, **B**, and **C**. The 20 m (65') CAN data cables from the wiredraw units to the collision avoidance modules are shown as green, and are labeled **WD A** for **Dolly A**, **WD B** for **Dolly B**, and so on. Yellow lines show the steel wiredraw cables extending to the dollies. The blue arrow indicates a 0.5 m (19") CAN data cable running between the two collision avoidance modules. Red arrows indicate 20 m (65') CAN data cables running from collision avoidance modules to camera systems.

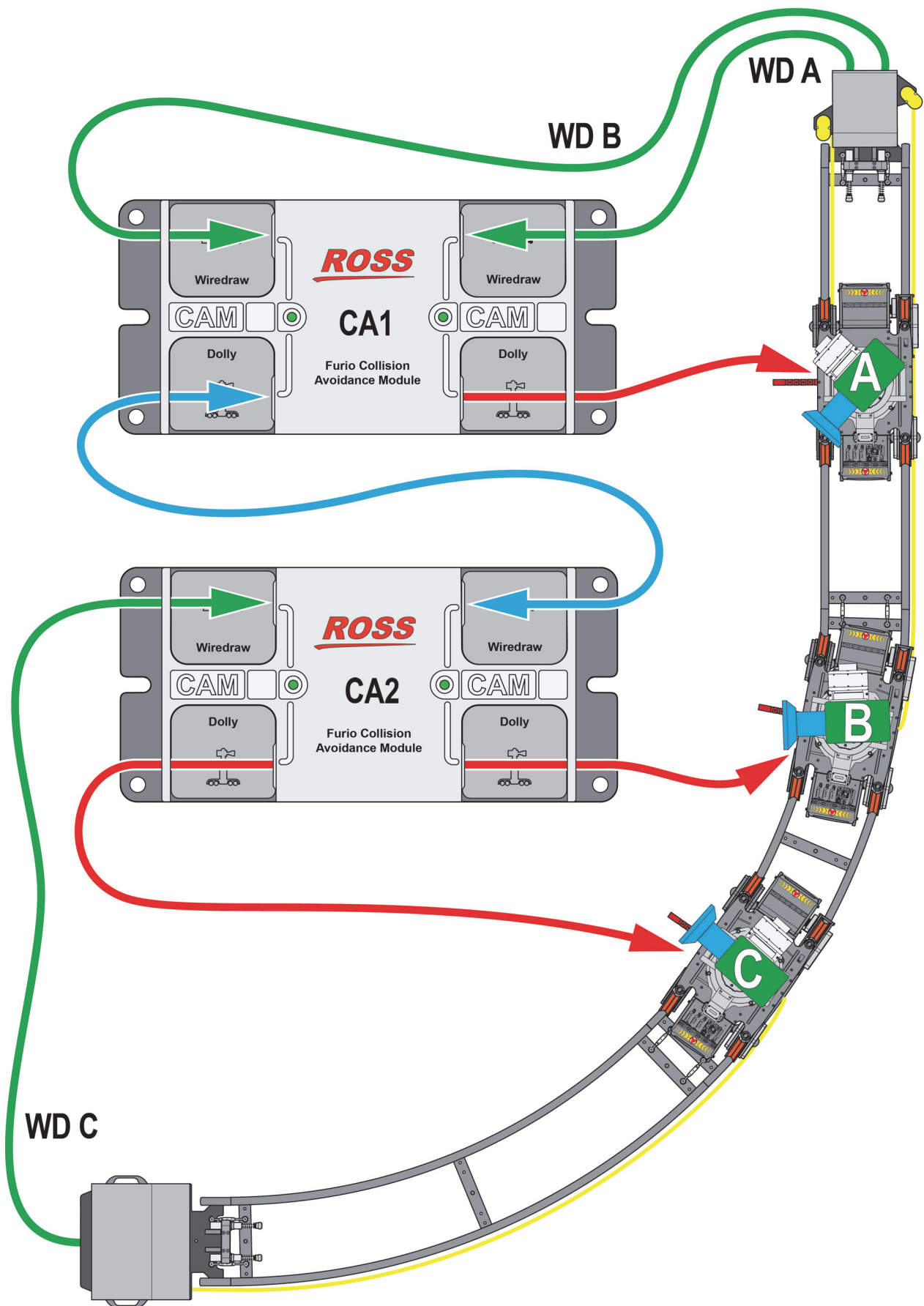

Figure 3.5 Collision Avoidance System Layout for Three Dollies

CAN Data Cable Connections for a Three-Dolly System

The CAN data cable connections are as follows:

For Dolly A:

- 20 m (65') data cable from the **wiredraw unit for Dolly A** to the **Top Right Socket of CA1**.
- 20 m (65') data cable from the **Bottom Right Socket** of CA1 to the **CAN A** socket on the **Dolly A connection panel** (see **Figure 3.6**).
- 2 m (6'6") data cable from the **CAN C** socket on the **Dolly A** connection panel (see **Figure 3.6**) to either the **NETWORK A** or **NETWORK B** socket on the **robotic pan/tilt head**.

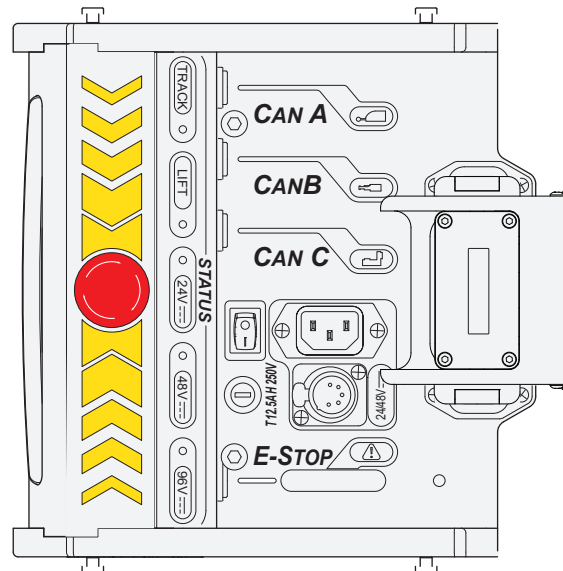

Figure 3.6 Connection Panel of the Furio SE Dolly, showing CAN Sockets (CAN A, CAN B, and CAN C)

For Dolly B:

- 20 m (65') data cable from the **wiredraw unit for Dolly B** to the **Top Left Socket of CA1**.
- 0.5 m (19") data cable from the **Bottom Left Socket** of CA1 to the **Top Right Socket of CA2**
- 20 m (65') data cable from the **Bottom Right Socket** of CA2 to the **CAN A** socket on the **Dolly B connection panel** (see **Figure 3.6**).
- 2 m (6'6") data cable from the **CAN C** socket on the **Dolly B** connection panel (see **Figure 3.6**) to either the **NETWORK A** or **NETWORK B** socket on the **robotic pan/tilt head**.

For Dolly C:

- 20 m (65') data cable from the **wiredraw unit for Dolly C** to the **Top Left Socket of CA2**.
- 20 m (65') data cable from the **Bottom Left Socket** of CA2 to the **CAN A** socket on the **Dolly C connection panel** (see **Figure 3.6**).
- 2 m (6'6") data cable from the **CAN C** socket on the **Dolly C** connection panel (see **Figure 3.6**) to either the **NETWORK A** or **NETWORK B** socket on the **robotic pan/tilt head**.

Collision Avoidance System Layout for Four Dollies

This section of the Setup Guide describes the supported layout for a four-dolly Furio system with collision avoidance.

When you connect CAN data cables to the collision avoidance modules, they must be connected exactly as shown. Other cable configurations may cause the collision avoidance system to fail.

This section of the Setup Guide refers to connection sockets on the collision avoidance modules, as shown in

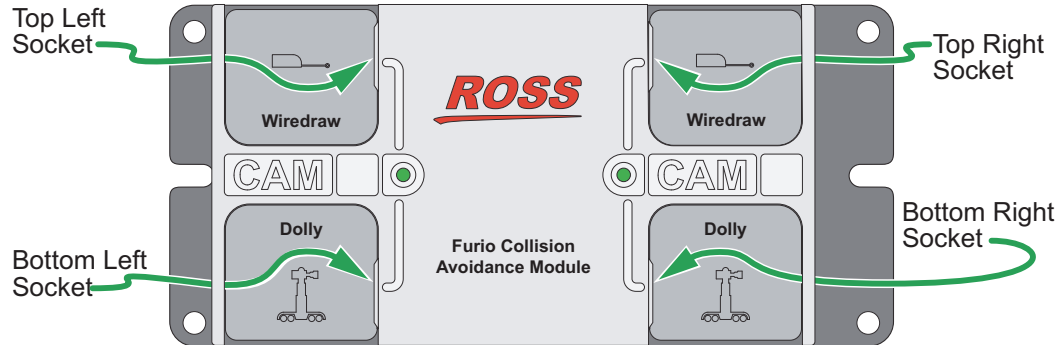

Figure 3.7.

Figure 3.7 How This Section of the Setup Guide Refers to Connector Sockets on the Collision Avoidance Module

Four-dolly systems have two 15 m (49') wiredraw encoders at each end of the track. Unless the track is less than 20 m (65') long, the three collision avoidance modules must be installed somewhere between the two ends of the track. The modules are installed together, and must be within 20 m (65') cable distance of each wiredraw unit and each dolly. Be sure to account for the full range of track motion for all dollies.

Figure 3.8 illustrates CAN data cable connections for a four-dolly system. The data cables must be connected exactly as shown. In **Figure 3.8**, the collision avoidance modules are labeled as **CA1**, **CA2**, and **CA3**. The camera systems (dollies) are labeled **A**, **B**, **C**, and **D**. The 20 m (65') CAN data cables from the wiredraw units to the collision avoidance modules are shown as green, and are labeled **WD A** for **Dolly A**, **WD B** for **Dolly B**, and so on. Yellow lines show the steel wiredraw cables extending to the dollies. Blue arrows indicate 0.5 m (19") CAN data cables running between collision avoidance modules. Red arrows indicate 20 m (65') CAN data cables running from collision avoidance modules to camera systems.

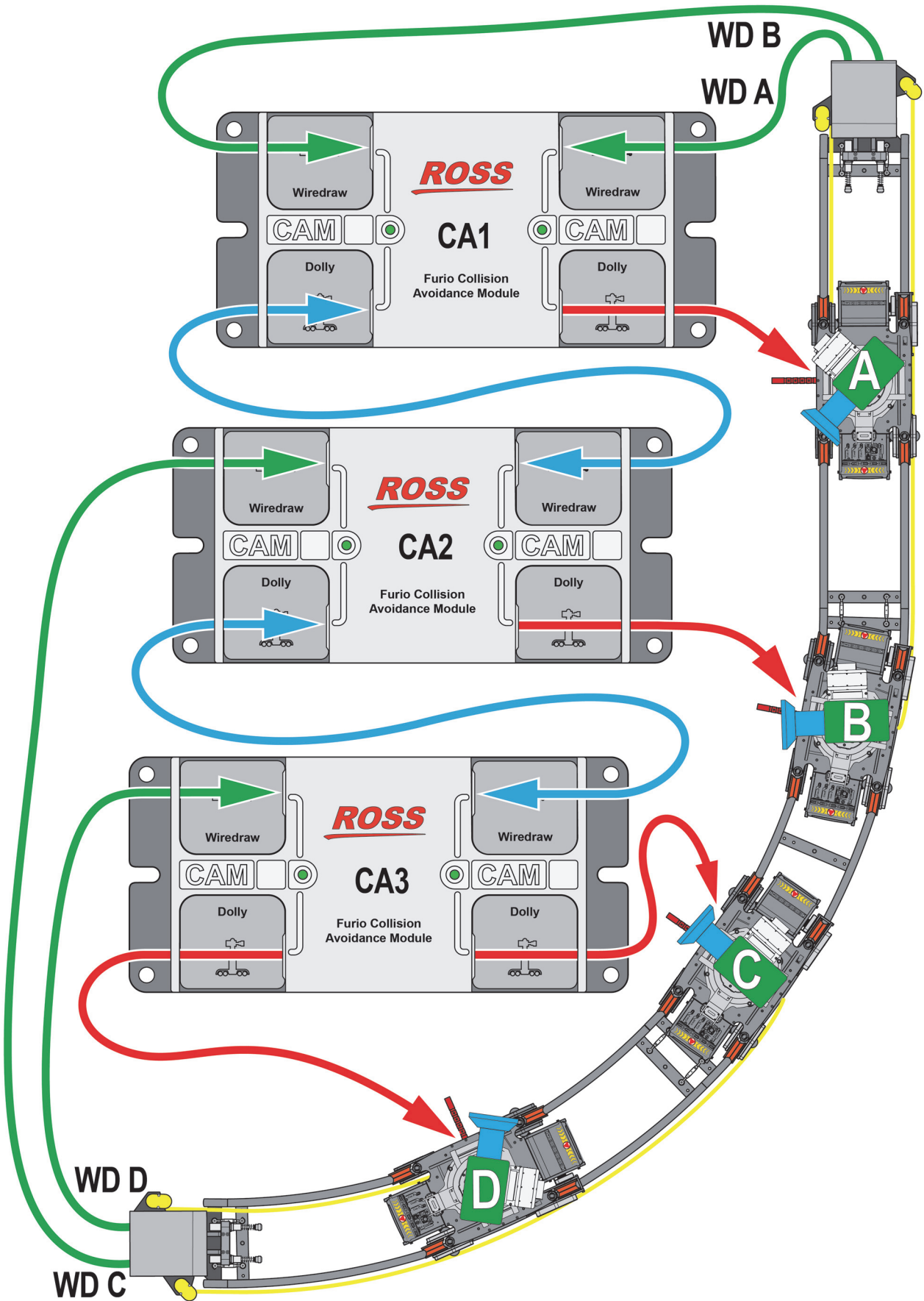

Figure 3.8 Collision Avoidance System Layout for Four Dollies

CAN Data Cable Connections for a Four-Dolly System

The CAN data cable connections are as follows:

For Dolly A:

- **20 m (65')** data cable from the **wiredraw unit for Dolly A** to the **Top Right Socket of CA1**.
- **20 m (65')** data cable from the **Bottom Right Socket** of CA1 to the **CAN A socket** on the **Dolly A connection panel** (see **Figure 3.9**).
- **2 m (6'6")** data cable from the **CAN C socket** on the **Dolly A connection panel** (see **Figure 3.9**) to either the **NETWORK A** or **NETWORK B** socket on the **robotic pan/tilt head**.

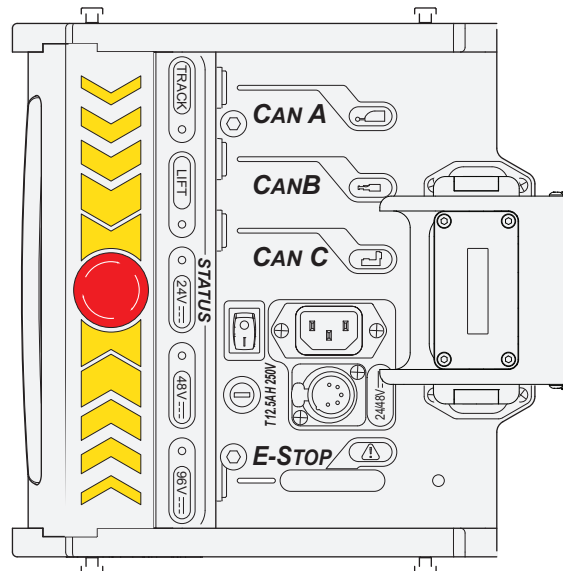

Figure 3.9 Connection Panel of the Furio SE Dolly, showing CAN Sockets (CAN A, CAN B, and CAN C)

For Dolly B:

- **20 m (65')** data cable from the **wiredraw unit for Dolly B** to the **Top Left Socket of CA1**.
- **0.5 m (19")** data cable from the **Bottom Left Socket** of CA1 to the **Top Right Socket of CA2**
- **20 m (65')** data cable from the **Bottom Right Socket** of CA2 to the **CAN A socket** on the **Dolly B connection panel** (see **Figure 3.9**).
- **2 m (6'6")** data cable from the **CAN C socket** on the **Dolly B connection panel** (see **Figure 3.9**) to either the **NETWORK A** or **NETWORK B** socket on the **robotic pan/tilt head**.

For Dolly C:

- **20 m (65')** data cable from the **wiredraw unit for Dolly** to the **Top Left Socket of CA2**.
- **0.5 m (19")** data cable from the **Bottom Left Socket** of CA2 to the **Top Right Socket of CA3**
- **20 m (65')** data cable from the **Bottom Right Socket** of CA3 to the **CAN A socket** on the **Dolly C connection panel** (see **Figure 3.9**).
- **2 m (6'6")** data cable from the **CAN C socket** on the **Dolly C connection panel** (see **Figure 3.9**) to either the **NETWORK A** or **NETWORK B** socket on the **robotic pan/tilt head**.

For Dolly D:

- **20 m (65')** data cable from the **wiredraw unit for Dolly D** to the **Top Left Socket of CA3**.
- **20 m (65')** data cable from the **Bottom Left Socket** of CA3 to the **CAN A socket** on the **Dolly D connection panel** (see **Figure 3.9**).
- **2 m (6'6")** data cable from the **CAN C socket** on the **Dolly D connection panel** (see **Figure 3.9**) to either the **NETWORK A** or **NETWORK B** socket on the **robotic pan/tilt head**.

Test Data Connectivity

The collision avoidance module has two LEDs that indicate connectivity. Each LED corresponds to one side of the collision avoidance module.

IMPORTANT: Green LEDs do **NOT** guarantee collision avoidance! The LEDs indicate data connectivity only. When an LED is green, it indicates that its side of the collision avoidance module is receiving data from the other side. To achieve collision avoidance, all CAN data cables must be in the correct positions and the collision avoidance behavior settings on all dollies must be properly configured. For more information, see “**Configuration**” on page 4–25.

To test connectivity of the collision module:

1. Turn off all dollies.
2. Turn on all dollies.

The collision avoidance module(s) are powered by the dollies. When the dollies are starting, one or both LEDs on the collision avoidance module(s) may turn orange to indicate that startup is in progress.

3. Reboot all dolly heads and watch the LEDs on the collision avoidance module(s).

The LEDs should all turn green.

4. If the LEDs do not turn green, check all cable connections and then repeat this procedure.

Dress the Data Cables

Data cables must be positioned and dressed such that:

- they do not present a tripping hazard
- they are not subject to physical damage
- they allow full range of dolly motion without snagging
- any excess cable is stored safely
- the installation complies with local safety regulations and your studio’s policies

To position and dress the data cables:

1. Position the cables that run from the wiredraw units to the collision avoidance module(s).
2. To each dolly’s cable bundle, add the data cable that runs between the dolly and a collision avoidance module.

Note: This may not be possible if the cable bundles originate from the ends of the track.

Ensure that the cable bundles are properly dressed to relieve strain and to allow full range of motion without snagging.

Mount the Collision Avoidance Module(s)

Mount each collision avoidance module in a dry location where it will not be subject to physical damage.

Each collision avoidance module includes an installation kit which contains one set of hook-and-loop mounting pads, four wood screws, and four plastic anchors. The kit also includes a rubber anti-skid pad you can apply to the bottom of the module if you do not want to fasten the module in place.

There are three mounting options:

- Mount on a flat surface without puncturing the surface, using supplied hook-and-loop mounting pads.

Tip: If a collision avoidance module is located at the end of the track, you can use this option to attach it to the wiredraw enclosure.

- Mount on a flat surface using the supplied screws or other mechanical fasteners of your choice.

Tip: The mounting holes and slots on the collision avoidance module are designed for M4, M5, #8, and #10 size fasteners.

IMPORTANT: If you need to temporarily disconnect data cables to mount the collision avoidance module, ensure that the cables are labeled so you can easily reconnect them. The cables must be connected to the proper ports.

To mount a collision avoidance module using hook-and-loop mounting pads:

1. Determine the exact location where you want to mount the module.
The mounting location must allow enough space for connecting and disconnecting data cables. Ensure the mounting surface is flat, clean, and dry.
2. Examine the hook and loop mounting pads. The softer pad is the loop pad.
3. Peel the plastic protective sheet off the loop pad.
4. Align the adhesive side of the pad with the recessed area on the underside of the collision avoidance module, and then attach the pad to the module.
5. Peel the plastic protective sheet off the hook pad.
6. Align the adhesive side of the pad with the mounting location, and then attach the pad to the mounting surface.
7. Align the loop pad with the hook pad, and then press them together.

The hook and loop pads secure the module in place. For best results, rotate the module back and forth as you press it onto the hook pad, to fully seat the hooks and loops together.

To mount a collision avoidance module using wood screws or other mechanical fasteners:

1. Determine the exact location where you want to mount the module.
The mounting location must allow enough space for connecting and disconnecting data cables. Ensure the mounting surface is flat, clean, and dry. It must also be made of material that can accept the fasteners you plan to use.
2. Referring to the mounting diagram **Figure 3.10**, determine where to install the fasteners.

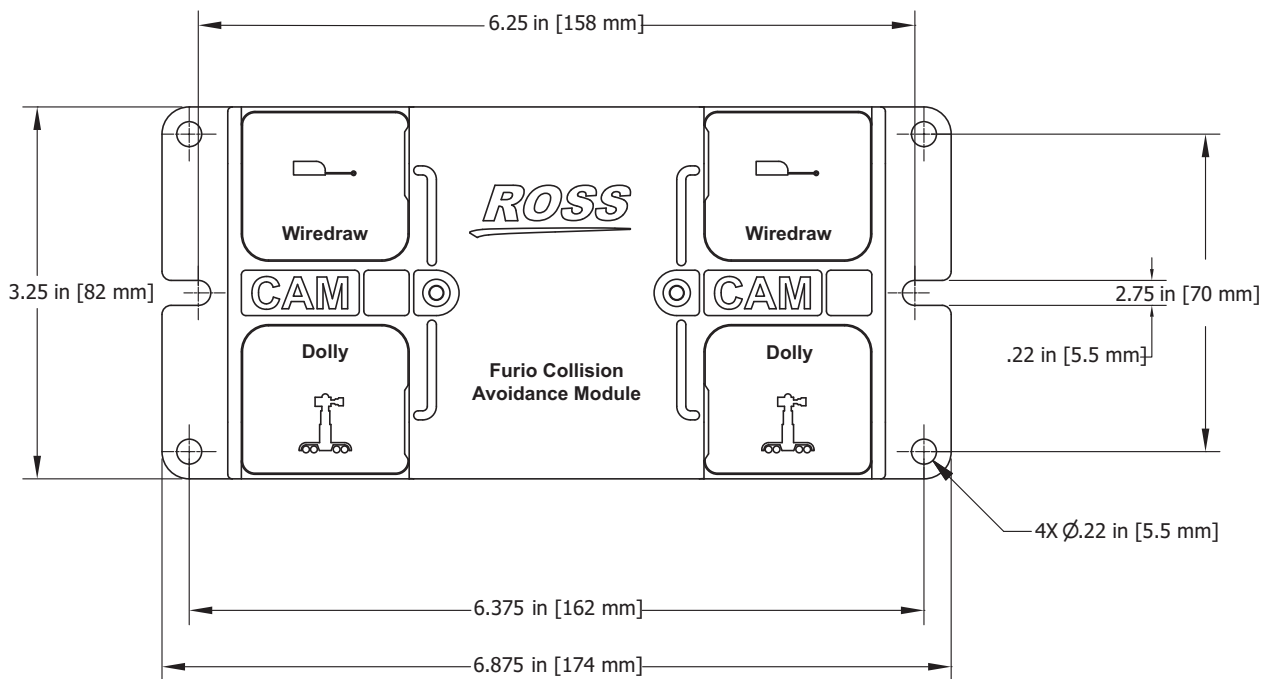

Figure 3.10 Mounting diagram showing the two end notches and four corner holes

Each collision avoidance module has two end notches and four corner holes that accept #8, #10, M4, or M5 size fasteners. You can use the two end notches, or two corner holes diagonally across from each other, or all four corner holes.

3. If you are using fasteners other than those provided, prepare the surface and install the module.
Skip the remaining steps.
4. If you are using the fasteners provided, on the mounting surface mark the positions where you want to install the fasteners.
5. Drill pilot holes as follows:
 - If you are attaching to a solid surface that can accept screw threads, such as wood, plastic anchors are not required. Drill 2 mm (3/32") pilot holes.
 - If you are attaching to a surface that requires plastic anchors, such as drywall or concrete, drill 5 mm (3/16") pilot holes.
6. Insert the plastic anchors into the holes, if required.
7. Align the collision avoidance module with the holes, and then fasten it down using the supplied screws. Do not overtighten.

To attach the rubber anti-skid pad:

1. Peel the plastic protective sheet off the rubber anti-skid pad.
2. Align the adhesive side of the pad with the recessed area on the underside of the collision avoidance module, and then attach the pad to the module.

Configuration

This chapter includes instructions for configuring your Furio system to work with the Furio Collision Avoidance System. To ensure collision avoidance, you must perform some or all of the configuration tasks described in this chapter. Your system layout determines which tasks are required.

Before you configure your system for collision avoidance, ensure that

- the Furio system is completely set up and works properly
- The SmartShell computer is running SmartShell version 4.9 (or higher)
- the collision avoidance system hardware components are installed according to the instructions in the chapter, “**Hardware Installation**” on page 3–11.

IMPORTANT: Green LEDs do **NOT** guarantee collision avoidance! The LEDs indicate data connectivity only. When an LED is green, it indicates that its side of the collision avoidance module is receiving data from the other side. To achieve collision avoidance, all CAN data cables must be in the correct positions and the collision avoidance behavior settings on all dollies must be properly configured. For more information, see “**Configuration**” on page 4–25.

Note: The procedure in this chapter involve changing configuration settings on each dolly’s robotic head. After you configure the heads for collision avoidance, all existing presets and moves are lost and cannot be restored.

IMPORTANT: After you install and configure the collision avoidance module, you must test collision avoidance behavior to ensure the system is functioning as expected. You must also test collision avoidance behavior after any changes to the configuration of the robotic heads, and after any changes to the system hardware components. For information about testing collision avoidance behavior, see “**Test Collision Avoidance Behavior**” on page 4–36.

To configure collision avoidance behavior, you must perform the following configuration tasks in the order listed below:

- “**Calculate Parameter Values**” on page 4–25
- “**Edit the Configuration Template File**” on page 4–28
- “**Calibrate to a Common Reference Point At the Center of the Track**” on page 4–35
- “**Set Track Axis Limits**” on page 4–36
- “**Test Collision Avoidance Behavior**” on page 4–36

Calculate Parameter Values

This section contains procedures for calculating parameter values that you will need to know when you edit the configuration template file in a later procedure.

We recommend you make a list of the parameter values for each dolly (**Dolly A**, **Dolly B**, and so on) as you calculate them.

Designating a Mixed Track as Either Straight or Curved

Each dolly has a set of parameter values that must be calculated and recorded separately.

If your track has curved and straight portions, it is a mixed track.

Dynamic clearance, which is the minimum space maintained between dollies, can vary on mixed tracks. This variance can occur in the straight and/or curved portion of the track, depending on track layout and dolly configuration.

When calculating parameter values for configuration purposes, a track is considered to be either straight or curved. Normally, a mixed track is considered to be straight for such calculations.

When parameters are calculated based on a curved track, the track encoder counts are weighted more heavily if the wiredraw cable rides along the inside (shorter) rail. The parameter calculations compensate for the fact that the circumference of the inner rail is less than the circumference of the outside rail. If a mixed track includes a long straight section, a dolly that is configured for a curved track and has its wiredraw cable on the inner (short) rail counts too slowly on the straightaway, and may stay too far from its neighbor at the far end of the straight portion.

Negative effects of designating a mixed track as either curved or straight can be mitigated somewhat by adjusting the dynamic clearance values of the dollies.

Designating a mixed track as straight or curved can be done on a dolly-by-dolly basis. You may decide to consider a mixed track to be curved when calculating parameter values for one dolly, but straight when calculating parameter values for a different dolly. For example, if the track is curved at the **primary** end and straight at the **secondary** end, **Dolly A** travels almost exclusively on curved track while **Dolly D** travels on straight track.

You may decide to consider a mixed track curved if:

- The majority of the track is curved.
- Most or all of the dolly’s travel is on the curved portion.
- The curved portion has a tight radius and/or the central angle of the track’s arc is large (for example, if the curve makes a 120-degree turn).

Need Help?

If you have questions about the information in this section of the Setup Guide or about any subject related to Ross Video technologies, feel free to contact Ross Video Technical Support:

- Toll Free Technical Support: (+1) 613 · 652 · 4886
- After Hours Emergency: (+1) 613 · 349 · 0006
- E-mail (Technical Support): techsupport@rossvideo.com
- E-mail (General Information): solutions@rossvideo.com
- Website: <http://www.rossvideo.com>

Calculate Wiredraw Radius (WR)

Perform this procedure if your track is considered to be curved.

In this procedure, you calculate the radius of the arc along which a wiredraw cable would travel if it were to ride along the outer (longest) rail of the track. This is referred to as the **Wiredraw Radius (WR)**. The **WR** value is used to determine other configuration values. Calculate **WR** even if none of the wiredraw cables in your system rides along the outer rail.

To calculate the radius:

1. Read the label on a section of track to determine the nominal radius.

In the example shown in **Figure 4.1**, the part number is **FRO-TCB-R0250-030**. The **R0250** portion specifies the radius of the track section. Multiply this value (**0250**) by ten to get the number of millimeters. For the radius calculation, we start with the nominal track radius in millimeters, so the starting value in this example is **2500**.



Figure 4.1 Reading track labels to determine track radius

Tip: Nominal track radius is measured from the center of the circle to the center of the outside rail.

2. Add 12.5.

This is the value of **WR**. Record the value and keep it available for subsequent procedures.

Calculate UnitValue for the Track Encoder (UV_TE)

Perform this procedure once per dolly.

This procedure describes how to calculate the correct value for the **UnitValue** parameter, for the DataSource Track Encoder (**UV_TE**). This value is required for subsequent procedures.

If your track is curved, you must know the wiredraw radius (**WR**) value before you perform this procedure. For more information, see “**Calculate Wiredraw Radius (WR)**” on page 4–26.

In this procedure, you calculate the absolute value of **UV_TE**, and then determine its sign (positive or negative).

To calculate **UV_TE**:

1. Look at the position of the wiredraw cable and note which rail it travels along.
2. Note whether the track wiredraw encoder is a 15 m (49') unit or a 30 m (98') unit.
3. If the wiredraw encoder is a **15 m unit**, calculate the absolute value of **UV_TE**, based on the scenario that applies:
 - If the track is straight then **UV_TE = 315.07**.
 - If the track is curved and the wiredraw cable rides on the outer (long) rail, then **UV_TE = 315.07**.
 - If the track is curved and the wiredraw cable rides on the inner (short) rail, **UV_TE = 315.07 x (WR / (WR - 360))**.
4. If the wiredraw encoder is a **30 m unit**, calculate the absolute value of **UV_TE**, based on the scenario that applies:
 - If the track is straight, then **UV_TE = 500**.
 - If the track is curved and the wiredraw cable rides on the outer (long) rail, then **UV_TE = 500**.
 - If the track is curved and the wiredraw cable rides on the inner (short) rail, **UV_TE = 500 x (WR / (WR - 360))**.
5. Determine whether **UV_TE** is positive or negative:
 - If the wiredraw encoder for the dolly is **at the primary end** of the track, **UV_TE** is positive.
 - If the wiredraw encoder for the dolly is **at the secondary end** of the track, **UV_TE** is negative.
6. Apply the sign to the absolute **UV_TE** value and then record it as **UV_TE**. Keep it available for subsequent procedures.

IMPORTANT: Be sure to record which dolly the value is for.
7. Repeat this procedure until you have recorded a **UV_TE** value for each dolly in your system.

Calculate UnitValue for the Axis Track Motor (UV_AT)

Perform this procedure once per dolly.

This procedure describes how to calculate the correct value for the **UnitValue** parameter, for AxisTrack>Motor>MotorUnits (**UV_AT**). This value is used in subsequent procedures.

If your track is curved, you must know the wiredraw radius (**WR**) value before you perform this procedure. For more information, see “**Calculate Wiredraw Radius (WR)**” on page 4–26.

In this procedure, you calculate the absolute value of **UV_AT**, and then determine its sign (positive or negative).

To calculate UV_AT:

1. Look at the position of the drive wheels and note which rail they travel on.
2. If the track is curved, determine the **Motor Radius (MR)**, which is the radius of the center of the rail upon which the drive wheels travel:
 - If the drive wheels ride on the outer (long) rail, **MR** is equal to **WR** minus **12.5**.
 - If the drive wheels ride on the inner (short) rail, **MR** is equal to **WR** minus **372.5**.
3. Calculate the absolute value of **UV_AT**, based on the scenario that applies:
 - If the track is straight, then the absolute value of **UV_AT** = **1**.
 - If the track is curved and the drive wheels ride on the outer (long) rail, then the absolute value of **UV_AT** = **1**.
 - If the track is curved and the drive wheels ride on the inner (short) rail, then the absolute value of **UV_AT** = **((MR+360) / (MR))**.
4. Standing at the **primary** end of the track, and looking towards the dolly, determine whether **UV_AT** is positive or negative:
 - If the drive wheels are on the end of the dolly that is closest to you, then **UV_AT** is positive.
 - If the drive wheels are on the end of the dolly that is farthest from you, then **UV_AT** is negative.
5. Apply the sign to the absolute **UV_AT** value and then record it as **UV_AT**. Keep it available for subsequent procedures.

IMPORTANT: Be sure to record which dolly the value is for (**Dolly A**, **Dolly B**, **Dolly C**, or **Dolly D**).
6. Repeat this procedure until you have recorded a **UV_AT** value for each dolly in your system.

Edit the Configuration Template File

Each dolly's robotic head has a configuration template file, which contains various configuration settings. You must edit each head's configuration template file to enable collision avoidance. The resulting configuration template files are different for each head.

This section describes how to download the configuration template file from a head, edit it, and upload it back to the head.

IMPORTANT: Perform the procedures in this section for each head, one at a time. Starting with **Dolly A**, perform the procedures in this section, in the order in which they appear. Then perform the procedures for **Dolly B**, and so on.

Before you begin, you must know the following values:

- **Wiredraw Radius (WR)** for the dolly you are configuring (curved tracks only).
For more information, see “**Calculate Wiredraw Radius (WR)**” on page 4–26.
- **UnitValue for Track Encoder (UV_TE)** for each dolly (**Dolly A**, **Dolly B**, and so on).
For more information, see “**Calculate UnitValue for the Track Encoder (UV_TE)**” on page 4–27.
- **UnitValue for AxisTrack>Motor>MotorUnits (UV_AT)** for the dolly you are configuring.
For more information, see “**Calculate UnitValue for the Axis Track Motor (UV_AT)**” on page 4–27.

Editing the configuration template file for each dolly involves:

- “**Downloading and Backing Up the Configuration Template File**” on page 4–29
- “**Setting Dynamic Maximum and/or Dynamic Minimum**” on page 4–29
- “**Setting UnitValue Parameter for the Axis Track Motor**” on page 4–32

- “**Add a Virtual DataSource (for AR/VS applications only)**” on page 4–32
- “**Setting the UnitValue Parameter for the Track Encoder**” on page 4–33
- “**Setting Dynamic Clearance Distance**” on page 4–34
- “**Applying the Edited Configuration Template File**” on page 4–34

Downloading and Backing Up the Configuration Template File

This section describes how to download and back up a configuration template file from a dolly’s robotic head. Configuration template file names end in a **.tmpl** extension.

If you are configuring a head that is already part of **an existing system**, use the steps in this section to download and back up the configuration template file.

If you are setting up a **new head**, you must extract the configuration template file from the software distribution instead of downloading it from the head. This is because different versions of the configuration template file exist for different types of heads. You must extract the correct file for your head type. Extract the file, and then proceed to “**Setting Dynamic Maximum and/or Dynamic Minimum**” on page 4–29.

The **VR600** head uses a configuration template file named **vr600_conf.tmpl**.

The **VR100** head uses a configuration template file named **vrone_conf.tmpl**.

To download and back up the configuration template file:

1. On a computer connected to your Furio network, using a web browser, navigate to the IP address of the head you are configuring.

The web interface for the head opens in the web browser.

Note: Each head has a separate web interface. Be sure to use the correct IP address for the head you are configuring.

2. On the **Status and Logging** tab, right-click **Download Configuration Template** and select the option to save the **.tmpl** file locally.

Tip: Create a separate folder for each head’s file. The files for the heads may have identical names, and it is very important that each head receives its own file.

3. Make a backup copy of the file in a separate folder, in case you need to revert to it later.

Setting Dynamic Maximum and/or Dynamic Minimum

Which dynamic limit(s) in the configuration template file (**.tmpl** file) for each dolly are to be set depends on the number of dollies in the system.

If there are only two dollies:

- **Dolly A**, the dolly closest to the **primary** end of the track, gets a **dynamic maximum**.
- **Dolly B**, the dolly closest to the **secondary** end of the track, gets a **dynamic minimum**.

If there are three dollies:

- **Dolly A**, the dolly closest to the **primary** end of the track, gets a **dynamic maximum**.
- **Dolly B**, the dolly between **Dolly A** and **Dolly C**, gets a **dynamic minimum** AND a **dynamic maximum**.
- **Dolly C**, the dolly closest to the **secondary** end of the track, gets a **dynamic minimum**.

If there are four dollies:

- **Dolly A**, the dolly closest to the **primary** end of the track, gets a **dynamic maximum**.
- **Dolly B**, the dolly between **Dolly A** and **Dolly C**, gets a **dynamic minimum** AND a **dynamic maximum**.
- **Dolly C**, the dolly between **Dolly B** and **Dolly D**, gets a **dynamic minimum** AND a **dynamic maximum**.
- **Dolly D**, the dolly closest to the **secondary** end of the track, gets a **dynamic minimum**.

This section of the Setup Guide contains separate procedures for setting dynamic maximum or dynamic minimum.

The configuration template file (**.tmpl** file) contains segments of code applicable to both scenarios (dynamic maximum and dynamic minimum). By default these code segments are “commented out” by the presence of a number sign (#) at the beginning of each line. The required code segments can be activated by uncommenting them.

To set a dynamic maximum:

1. Open the configuration template file (**.tmpl** file) in a text editor.
2. Close to the top of the file, find the line that looks like one of the two following lines:

```
# - Collision Avoidance (Dynamic Limits) commented out
# - Dynamic Limits are set
```

3. Edit it to look like this:

```
# - Dynamic Limits are set
```

4. In the file, find the following line, make a copy of it, and paste the copy immediately below the original:

```
# DynamicMaximumSource REF { Param ref { Value <datasource_name>; };
};
```

Edit the copied line to look like this:

```
DynamicMaximumSource REF { Param ref { Value Track_Dynamic_Maximum;
}; };
```

5. In the file, find and uncomment the following segment of code by removing the number sign (#) from the start of each line:

```
# Node Track_Dynamic_Maximum {
# ID 34;
# Device Posital;
# };
```

6. In the file, find and uncomment the following segment of code by removing the number sign (#) from the start of each line:

```
# DataSource Track_Dynamic_Maximum {
# Type CAN {
# Param Node { Value Track_Dynamic_Maximum; };
# Param Index { Value 0x6004; };
# Param Subindex { Value 0; };
# Param BitDepth { Value 25; };
# };
# UnitValue 315.07;
# UnitCounts 8192;
# <tmpl_var name="DATA_SOURCE_OFFSET_Track_Dynamic_Maximum" />
# };
```

7. In the preceding code, replace the **UnitValue** value (**315.07** in this example) with the **UV_TE** value for the next dolly along the track. For example, if you are setting the dynamic maximum for **Dolly A**, use the **UV_TE** value for **Dolly B**.
8. Save the file. Leave it open for the next procedure.

To set a dynamic minimum:

1. Open the configuration template file (**.tmpl** file) in a text editor.
2. Close to the top of the file, find the line that looks like one of the two following lines:

```
# - Collision Avoidance (Dynamic Limits) commented out
# - Dynamic Limits are set
```

3. Edit the line to look like this:

```
# - Dynamic Limits are set
```

4. In the file, find the following line, make a copy of it, and paste the copy immediately below the original:

```
# DynamicMinimumSource REF { Param ref { Value
Track_Dynamic_Minimum; }; };
```

Edit the copied line to look like this:

```
DynamicMinimumSource REF { Param ref { Value Track_Dynamic_Minimum;
}; };
```

5. In the file, find and uncomment the following segment of code by removing the number sign (#) from the start of each line:

```
# Node Track_Dynamic_Minimum {
# ID 33;
# Device Posital;
# };
```

6. In the file, find and uncomment the following segment of code by removing the number sign (#) from the start of each line:

```
# DataSource Track_Dynamic_Minimum {
# Type CAN {
# Param Node { Value Track_Dynamic_Minimum; };
# Param Index { Value 0x6004; };
# Param Subindex { Value 0; };
# Param BitDepth { Value 25; };
# };
# UnitValue 315.07 ;
# UnitCounts 8192;
# <tmpl_var name="DATA_SOURCE_OFFSET_Track_Dynamic_Minimum" />
# };
```

7. In the preceding code, replace the **UnitValue** value (**315.07** in this example) with the **UV_TE** value for the previous dolly along the track. For example, if you are setting the dynamic maximum for **Dolly B**, use the **UV_TE** value for **Dolly A**.
8. Save the file. Leave it open for the next procedure.

Setting UnitValue Parameter for the Axis Track Motor

This procedure describes how to set the **UnitValue** for the Axis Track (**UV_AT**).

Before you begin, you must know the value you need to apply for **UV_AT**. Instructions for calculating **UV_AT** appear in an earlier section. For more information, see “**Calculate UnitValue for the Axis Track Motor (UV_AT)**” on page 4–27.

To set the UnitValue parameters for the axis track motor:

1. In the configuration template file (**.tmpl** file), find the **AXIS TRACK** segment of code, which closely resembles the following:

```
Axis Track {
  Param Tolerance { Value 10; };
  Motor 0 {
    Param MaxDeceleration { Value 15000; };
    Param SoftLimitDecel { Value 5000; };
    Param VelocityCorrection { Value TRUE; };
    Param SlavingVelocity{ Value 1200000; };
    Param SlavingAcceleration { Value 15000; };
    Param SlavingDeceleration { Value 15000; };
    Param AutomationVelocity{ Value 1200000; };
    Param AutomationAcceleration { Value 3000; };
    Param AutomationDeceleration { Value 3000; };
    Node Track;
    NegativeSwitch 4; # V3 dolly=3, V1 dolly=4
    PositiveSwitch 5; # V3 dolly=2, V1 dolly=5
    Frequent 1;
    MustHome;
    MotorUnits {
      UnitValue -1;
      UnitCounts 126;
    };
    Home ExternalAbsolute {
      Source REF {
        Param Ref { Value Track_Encoder; };
      };
    };
  };
};
```

2. In the preceding code, replace the **UnitValue** value (-1 in this example) with the **UV_AT** value you calculated for the dolly.
3. Save the file. Leave it open for the next procedure.

Add a Virtual DataSource (for AR/VS applications only)

Perform the steps in this section only if **ALL** of the following are true:

- You require position data from the dolly to support an AR/VS application.
- The wiredraw cable for the dolly rides along the inside (short) rail of the track.

- You changed the **UV_TE** value from its default because the track is curved or mixed shape.
Tip: The default value of **UV_TE** is **315.07** for a 15m (49') wiredraw, or **500** for a 30m (98') wiredraw.

To add a virtual DataSource (DataSource Track_Encoder_Virtual):

- In the configuration template file (.tmpl file), find the **DataSource Track_Encoder** segment of code, which closely resembles the following:

```
DataSource Track_Encoder {
    Type CAN {
        Param Node { Value Track_Encoder; };
        Param Index { Value 0x6004; };
        Param Subindex { Value 0; };
        Param BitDepth { Value 25; };
    };
    UnitValue 315.07;
    UnitCounts 8192;
    <tmpl_var name="DATA_SOURCE_OFFSET_Track_Encoder" />
};
```

- Copy the entire code segment and paste it into the configuration template file.
- Edit the pasted segment to make the first line read as follows:

```
DataSource Track_Encoder_Virtual {
```

- Edit the line that defines the **tmpl_var** argument to read as follows:

```
<tmpl_var name="DATA_SOURCE_OFFSET_Track_Encoder_Virtual" />
```

- Find the following code segment:

```
Source REF {
    Param Axis { Value DOLLY; };
    Param Ref { Value Track_Encoder; };
};
```

- Edit the Param Ref line to read as follows:

```
Param Ref { Value Track_Encoder_Virtual; };
```

- Save the file. Leave it open for the next procedure.

Setting the UnitValue Parameter for the Track Encoder

This procedure describes how to set the **UnitValue** for the Track Encoder (**UV_TE**).

Before you begin, you must know the value you need to apply for **UV_TE**. Instructions for calculating **UV_TE** appear in an earlier section. For more information, see “**Calculate UnitValue for the Track Encoder (UV_TE)**” on page 4-27.

To set the UnitValue parameters for the Track Encoder:

- In the configuration template file (.tmpl file), find the **DataSource Track_Encoder** segment of code, which closely resembles the following:

```
DataSource Track_Encoder {
    Type CAN {
        Param Node { Value Track_Encoder; };
```

```

    Param Index { Value 0x6004; };
    Param Subindex { Value 0; };
    Param BitDepth { Value 25; };
};
UnitValue 315.07;
UnitCounts 8192;
<tmpl_var name="DATA_SOURCE_OFFSET_Track_Encoder" />
};

```

2. In the preceding code, replace the **UnitValue** value (**315.07** in this example) with the **UV_TE** value you calculated for the dolly.
3. Save the file. Leave it open for the next procedure.

Setting Dynamic Clearance Distance

The dynamic clearance distance determines how close any pair of dollies are allowed to come to each other. The collision avoidance system slows and/or stops one or both dollies to prevent them from getting too close.

The dynamic clearance distance is the distance between dolly centers, in millimeters. By default it is set to 1600mm, which prevents the dollies from touching each other. We recommend you set the same clearance distance for each dolly.

If the dolly is carrying a payload that extends past the ends of the dolly, you must adjust the clearance distance accordingly.

Dynamic clearance can vary on mixed tracks. This variance can occur in the straight and/or curved portion of the track, depending on track layout and dolly configuration. After configuring and testing the collision avoidance system, you may need to adjust dynamic clearance to maintain an ideal minimum distance between dollies.

To set the Dynamic Clearance distance:

1. In the configuration template file (**.tmpl** file), find and uncomment the following line by removing the number sign (#):

```
# DynamicClearance 1600;
```

2. If you want to set **DynamicClearance** to a different value, replace **1600** with the new value, in millimeters.
IMPORTANT: DynamicClearance is the distance between the **CENTERS** of the dollies, in millimeters. **DO NOT** set it a value lower than **1600**. Lower values may allow dollies to collide.
3. Save the file.

Applying the Edited Configuration Template File

To apply the configuration template file you edited:

1. In a web browser, open the web interface for the dolly.
2. On the **Upgrade** tab, click **Browse**, and then select the configuration template file (**.tmpl** file) you edited.
3. Click the **Upload File and Reboot** button.

The dolly head reboots and applies the new configuration file.

4. Unless this is the final dolly (highest letter), go to “**Edit the Configuration Template File**” on page 4–28 and repeat all the procedures you just completed, but for the next dolly along the track.

Calibrate to a Common Reference Point At the Center of the Track

All dollies must be calibrated to a common reference point in order for each dolly to know the position of its neighbor(s).

Note: After you perform this procedure, any previously-created presets and moves will not work properly.

To calibrate dollies to the common reference point:

1. Turn all dollies **OFF**.
2. Find a joint between two sections of track, close to the middle of the track. The joint line will act as a common reference point for all dollies.
3. Manually position a dolly so that the center of its wiredraw post is perfectly aligned with the common reference point.
4. Turn the dolly **ON**.
5. On a computer connected to your Furio network, use a web browser to navigate to the IP address of the head you are configuring.

The web interface for the head opens in the web browser.

Note: Each head has a separate web interface. Be sure to use the correct IP address for the head you are configuring.

6. On the **Status and Logging** tab, record the encoder position for the track axis.
You will later transfer this value to neighboring dollies.
7. Save changes and reboot.
8. Turn the dolly **OFF** and move it away from the common reference point.
9. Repeat **Steps 3 to 8** until you have performed them for all dollies.
You now have a list of offset values for each dolly.
10. Turn on all dollies.
11. Starting with **Dolly A**, which is closest to the **Primary** end of the track, and continuing with **Dolly B** and so on towards the **Secondary** end of the track, configure **Dynamic Minimum** and/or **Dynamic Maximum** offsets as follows:
 - a. In a web browser, open the web interface for the dolly's head by navigating to the head's IP address.
 - b. On the **Axis Settings** tab, click **Enable Edit**.
 - c. For track offset, specify the offset value for the dolly you are configuring.
 - d. If the dolly has a neighboring dolly closer to the **Secondary** end of the track: For **Dynamic Maximum offset**, specify the offset value for that neighboring dolly. For example, if you are configuring **Dolly A**, specify the offset value for **Dolly B**.
 - e. If the dolly has a neighboring dolly closer to the **Primary** end of the track: For **Dynamic Minimum offset**, specify the offset value for that neighboring dolly. For example, if you are configuring **Dolly B**, specify the offset value for **Dolly A**.
 - f. Save changes and reboot.
 - g. Repeat **Steps a to f** for each dolly.

Set Track Axis Limits

As part of configuration process, you must limit how far each dolly can move along the track. Limits prevent the dollies from colliding with the bumpers at the ends of the track. For layouts where the track is longer than the range of one or more wiredraw units, limits also prevent each dolly from pulling its wiredraw cable too far and damaging the wiredraw unit.

To set track axis limits for a dolly:

1. On a computer connected to your Furio network, using a web browser, open the web interfaces the dolly you want to configure.
2. Clear the **Track Axis** limits:
 - a. In the web interface, open the **Axis Settings** tab.
 - b. Click the **Enable Edit** button.
 - c. Scroll down to the **Axis Properties** section.

Each axis of motion is represented, including the **Track** axis.
 - d. In the **TRACK** section, click both of the **Clear** buttons.
3. Manually drive the dolly as close to the **Primary** end of the track as you want it to be able to travel.

Tip: If approaching the end of the track, move the dolly slowly to prevent it from colliding with the bumpers. Leave a safety margin distance of 0.5 m (19") or more between the dolly and the bumpers.
4. On the **Axis Settings** tab, scroll to the **TRACK** section.
5. In the **TRACK** section, beside the **New Low Limit** box, click the **Set Current** button.

Leave the browser window open so the **TRACK** section remains visible.
6. Manually drive the dolly as close to the **Secondary** end of the track as you want it to be able to travel.

IMPORTANT: If the track is longer than the wiredraw range for the dolly, you must be careful not to move the dolly past the wiredraw range. Measure the distance from the wiredraw unit to where you want to set the track limit. If the track layout is curved or mixed shape, measure along the rail that the wiredraw rides along. Allow 1 m (3') as a safety margin. For example, if the dolly has a 15 m (49') wiredraw, measure 14 m (46'), and then move the dolly so that the center of the dolly, where the wiredraw is attached, is at the 14m mark.
7. In the web interface, beside the **New High Limit** box, click **Set Current**.
8. Scroll to the bottom of the web interface and click **Save**.
9. Repeat **Steps 1 to 8** to set track limits for each dolly.

After track limits are set, all configuration related to collision avoidance is complete. You can close the web interfaces, or perform other configuration tasks such as setting axis limits for other axes.

Test Collision Avoidance Behavior

IMPORTANT: After you install and configure the collision avoidance module, you must test collision avoidance behavior to ensure the system is functioning as expected. You must also test collision avoidance behavior after any changes to the configuration of the robotic heads, and after any changes to the system hardware components. For information about testing collision avoidance behavior, see “**Test Collision Avoidance Behavior**” on page 4–36.

Before you test collision avoidance behavior, ensure that:

- The Furio dolly system is fully set up, turned on, and operational.
- All collision avoidance modules are connected and show two green LEDs.
- All preceding configuration procedures in this chapter have been completed as required, for all dollies.

To test collision avoidance behavior:

1. Using manual controls, move all dollies as far as possible towards the **Secondary** end of the track.

WARNING: If a wiredraw cable extends beyond its rated length, the wiredraw unit may be permanently damaged. If the track is longer than the range of the dolly's wiredraw unit, monitor the distance between the dolly and its wiredraw unit to ensure that the wiredraw is never fully extended. Track limits you set previously should prevent the dolly from traveling too far.

2. Starting with **Dolly A**, then **Dolly B**, and so on:

- a. Check whether the clearance distance on the **Secondary** side of the dolly is adequate and not excessive. Be sure to take the size of the intended payload into account if it could extend beyond the dolly.
- b. Move the dolly as far as possible towards the **Primary** end of the track.

WARNING: If a wiredraw cable extends beyond its rated length, the wiredraw unit may be permanently damaged. If the track is longer than the range of the dolly's wiredraw unit, monitor the distance between the dolly and its wiredraw unit to ensure that the wiredraw is never fully extended. Track limits you set previously should prevent the dolly from traveling too far.

- c. Check whether the clearance distance on the **Primary** side of the dolly is adequate and not excessive. Be sure to take the size of the intended payload into account if it could extend beyond the dolly.

3. If the clearance between a dolly and an end of the track is too large or small, adjust the dolly's axis track limits. For more information, see "**Set Track Axis Limits**" on page 4–36.
4. If the minimum distance between two dollies is too large or too small, adjust their dynamic clearance values. For more information, see "**Setting Dynamic Maximum and/or Dynamic Minimum**" on page 4–29.

Troubleshooting

If an LED on a collision avoidance module turns red, it means that side of the module is no longer receiving positional data from the other side. If both LEDs turn red, neither side of the collision avoidance module is receiving data from the other.

To restore data connectivity:

1. Turn off all dollies.
2. Wait 30 seconds and then turn on all dollies.
3. If one or both LEDs on a collision avoidance module are still red, log on to each dolly's web interface to check whether all nodes are operational. Specifically, check for node 33 if the dolly is configured with a dynamic minimum, or node 34 if it has a dynamic maximum.
4. If any nodes are not operational, check all cable connections and repeat steps 1 to 3.
5. If one or both LEDs are still red, contact technical support.

