

# Furio SkyDolly Site Requirements

All Ross Robotics systems consist of control room equipment and studio equipment.

This document specifies site requirements to accommodate Furio SkyDolly studio equipment. It includes the following sections:

- “**About the Furio SkyDolly System**” on [page 2](#)
- “**General Studio Requirements**” on [page 7](#)
- “**Power and Networking Requirements**” on [page 9](#)
- “**Technical Requirements for the Suspended Track System**” on [page 9](#)

**Ask Us Anything** — Ross Video is pleased to provide guidance and answer any questions you might have about planning your installation. Our friendly, experienced Program Managers can help you achieve an efficient and trouble-free installation.

**IMPORTANT:** Ross Robotics always strives to provide excellent customer service. Unless explicitly stated otherwise, installation of equipment provided by Ross Robotics must be performed by Ross-qualified personnel only. If any non-qualified and/or unauthorized persons unpack and/or attempt to install equipment provided by Ross Robotics, the warranty is voided and any actions required to correct the installation and/or repair the equipment will be at the expense of the customer and/or systems integrator.

## For More Information About...

- Control room site requirements for Ross Robotics systems that use a Standard SmartShell Control Station, which features separate computers for SmartShell and the Robotics Server, see **Control Room Site Requirements for Standard Control Station (5100DR-021-xx)**.
- Control room site requirements for Ross Robotics systems that use a Standalone SmartShell Control Station with Integrated Server, see **Control Room Site Requirements for Standalone Control Station with Integrated Server (5100DR-032-xx)**.
- Studio site requirements for Furio robots other than SkyDolly, see **Furio Studio Site Requirements (5100DR-023-xx)**.
- Studio site requirements for CamBot robots, see **CamBot Studio Site Requirements (5100DR-022-xx)**.
- Components of the SkyDolly system, and maintenance of the system, see **Technical Manual for Furio SkyDolly (5100DR-074-xx)**.
- Ross Robotics products and accessories, and for product brochures, contact your Ross Video sales representative.

## About the Furio SkyDolly System

The Furio SkyDolly system features one or two robotic dollies riding on a suspended track mounted to a dedicated truss assembly.

Components of the SkyDolly robotic camera dolly are designed to be modular. Each dolly includes one of three heads, the Furio heads (VR100 or VR600) or the X-350, a Barcode Positioning System (BPS) unit, and either a fixed-height column (various lengths available) or a two-stage Furio S2 robotic lift. The dolly's electronic controls are contained within a field-replaceable unit (Main FRU). Each dolly features four auxiliary power outlets (IEC C13 female) for powering the camera and accessories.

Two-robot systems may also include an Ethernet-Based Collision Avoidance System or legacy Furio Collision Avoidance module, which helps prevent robotic dollies from colliding with each other. The Furio SkyDolly robots are operated from a SmartShell control station, which can also control all other Ross Video robotic camera systems.

**Note:** The VR100 pan tilt has been End of Production since June 16th 2023. Product support is available for 7 years following the EOP date. Hardware maintenance is available to purchase but cannot exceed the EOP date. To learn more about upgrading your Furio Robot Package, contact your regional sales manager.

## Furio SkyDolly Robot Packages

Each SkyDolly robot package includes one or more robotic components (dolly, lift, head) and may also include a fixed-height column. All other system components and accessories are sold separately. Truss and track layouts are custom-designed for each installation.

Full robot packages include a SkyDolly, a robotic pan/tilt head, and either a robotic lift or a fixed-height column.

Upgrade packages include one or more supplemental robotic components that enable customers to enhance an existing robot. Once upgraded, the robot consists of the same components as one of the full robot packages.

### SkyDolly robot packages are as follows:

- **FRO-SKY-X350-DLY** — Full robot package consisting of an X350 pan/tilt head attached to a Furio SkyDolly via a fixed-height column.
- **FRO-SKY-VR600-DLY** — Full robot package consisting of a Furio VR600 pan/tilt head attached to a Furio SkyDolly via a fixed-height column.
- **FRO-SKY-VR100-DLY** — Full robot package consisting of a Furio VR100 pan/tilt head attached to a Furio SkyDolly via a fixed-height column.
- **FRO-SKY-X350-FULL-S2** — Full robot package consisting of an X350 pan/tilt head attached to a Furio SkyDolly via a Furio S2 two-stage robotic lift.
- **FRO-SKY-VR600-FULL-S2** — Full robot package consisting of a Furio VR600 pan/tilt head attached to a Furio SkyDolly via a Furio S2 two-stage robotic lift.
- **FRO-SKY-VR100-FULL-S2** — Full robot package consisting of a Furio VR100 pan/tilt head attached to a Furio SkyDolly via a Furio S2 two-stage robotic lift.
- **FRO-SKY-DLY-UPG** — Upgrade package consisting of a Furio SkyDolly plus fixed-height column, without a robotic head. This package is suitable for customers who already own a Furio VR100 or VR600 robotic head and want to upgrade to a full suspended-track SkyDolly system.
- **FRO-SKY-FULL-S2-UPG** — Upgrade package consisting of a Furio SkyDolly plus Furio S2 two-stage lift, without a robotic head. This package is suitable for customers who already own a Furio VR100 or VR600 robotic head and want to upgrade to a full suspended-track SkyDolly system.
- **FRO-SKY-S2-UPG** — Upgrade package consisting of a Furio S2 two-stage lift only. This package is suitable for customers who already own a Furio SkyDolly system and want to add a robotic lift to a dolly.



## Furio Robotic Heads

Each SkyDolly camera system features one of the following Furio robotic pan-tilt heads:

- **X-Series X350**

The X350 is ideal for flexible mounting options and an ultra-compact footprint.

**Key Features and Specs:**

- › Payload: 6.8 kg (15 lbs)
- › Maximum pan/tilt speed: 45 degrees per second
- › Net weight of head: 5.3 kg (11.6 lbs)
- › 5" touchscreen display that aids setup and configuration, which can be used as a Tally/camera number
- › Encoded pan and tilt motors
- › Suitable for virtual set and augmented reality applications

- **Furio VR600**

The VR600 is ideal for larger cameras, lenses, and prompting systems.

**Key Features and Specs:**

- › Payload: 30 kg (66 lbs) when mounted on Furio SkyDolly, 57 kg (125 lbs) standalone
- › Maximum pan/tilt speed: 90 degrees per second
- › Net weight of head: 25 kg (55 lbs)
- › Encoded pan and tilt motors. Suitable for virtual set and augmented reality applications
- › Maximum teleprompter size: 48 cm (19")

- **Furio VR100**

The VR100 is ideal for EFP/ENG cameras.

**IMPORTANT:** The VR100 pan tilt has been End of Production since June 16th 2023. Product support is available for 7 years following the EOP date. Hardware maintenance is available to purchase but cannot exceed the EOP date. To learn more about upgrading your Furio Robot Package, contact your regional sales manager.

**Key Features and Specs:**

- › Payload: up to 20 kg (44 lbs)
- › Maximum pan/tilt speed: 60 degrees per second
- › Net weight of head: 13.3 kg (29.3 lbs)
- › Encoders on the final stages of the pan and tilt axes. Excellent for virtual set and augmented reality applications
- › Maximum teleprompter size: 38 cm (15")

## Barcode Positioning System (BPS)

The Barcode Positioning System (BPS) replaces traditional wired encoders in all Furio Studio models effective July 2024. This transition enhances the precision, reliability, and maintenance of the system.

### Environmental Requirements

- **Humidity:** 0% to 90% relative humidity, non-condensing.
- **Lighting:** Avoid direct exposure to intense, direct lighting; ensure consistent lighting conditions.
- **Cleanliness:** Maintain a clean environment; regular cleaning of barcode tape and sensors with a soft cloth and commercial glass cleaner.



## Installation and Mounting

When mounting the BPS unit and installing barcode tape:

- Ensure barcode tape is free of wrinkles and mechanical tension.
- Barcode tapes are available in the following lengths:
  - › 10 meters (Product Code FRO-BPS-TAPE-10)
  - › 20 meters (Product Code FRO-BPS-TAPE-20)
  - › 30 meters (Product Code FRO-BPS-TAPE-30)
  - › 40 meters (Product Code FRO-BPS-TAPE-40)
  - › 50 meters (Product Code FRO-BPS-TAPE-50)
  - › 70 meters (Product Code FRO-BPS-TAPE-70)

## Maintenance

Routine checks include:

- Regularly inspect barcode tape for wear or damage.
- Clean optical sensors and barcode tape to ensure accurate readings.
- Perform firmware updates as needed via Ross Video customer service.

## SkyDolly Travel Range and Maximum Dolly Track Length

The dolly track is the set of rails upon which the dolly rides. There is also a set of two safety rails above the dolly track to ensure that the dolly cannot possibly fall. Cable trolleys ride upon the safety rails, which extend beyond the end of the dolly track to provide a stackup zone for the trolleys and cable bundle.

The maximum number of dollies on a single track is two. If there are two dollies only one BPS tape needs to be installed.

The maximum dolly track length for a two-dolly system varies based on the length of the fixed-height column (or the use of the Furio S2 lift), due to factors related to accommodating the cable bundle that runs from the dolly to the end of the track ([Table 1](#)).

**Table 1: Maximum Dolly Track Lengths, Tow Cable Lengths, and Number of Cable Trolleys**

| Fixed-Height Column or Lift         | Maximum Dolly Track Length | Length of Each Tow Cable | Maximum Number of Cable Trolleys Required |
|-------------------------------------|----------------------------|--------------------------|---|
| FRO-FCO-7-SE — 17.8 cm (7") column  | 24.6 m (80', 8")           | 1.2 m (47.25")           | 21  |
| FRO-FCO-12-SE — 30 cm (12") column  | 24.6 m (80', 8")           | 1.2 m (47.25")           | 21  |
| FRO-FCO-30-SE — 76 cm (30") column  | 25.3 m (83', 0")           | 1.5 m (59.0")            | 17  |
| FRO-FCO-48-SE — 122 cm (48") column | 26.1 m (85', 7")           | 2.0 m (78.75")           | 13  |
| Furio S2 robotic lift               | 26.1 m (85', 7")           | 2.0 m (78.75")           | 13  |





## Furio SkyDolly Tracks

The Furio SkyDolly suspended track system consists of standard components assembled into a layout that is custom designed for each installation.

SkyDolly track can be curved, straight, or a combination (such as U-shaped). Nominal track width is 50 cm (19.7"), as measured from the centerlines of the two dolly rails, upon which the SkyDolly travels.

Curved track sections are custom-made to the desired radius. The minimum radius is 3 m (9.8') to the centerline of the outside rail, which corresponds to a radius of 2.5 m (8.2') to the centerline of the inside rail. The maximum radius is unlimited.

The BPS barcode tape must be installed smoothly along track curves without any wrinkles or mechanical tension. The scanning beam should be oriented at an incline of approximately 7° to the barcode tape throughout the curve.

For information about technical requirements for installation of Furio SkyDolly track systems, see "**Technical Requirements for the Suspended Track System**" on [page 9](#).

## Track Geometry Limitations When Operating with AR/VS Applications

### Minimum Length Requirement

In AR/VS applications, each continuous curved segment, whether it consists of a single track piece or multiple adjacent sections of the same radius, must have an inner rail length at least equal to the dolly wheelbase. For the Furio SkyDolly, the wheelbase is 800 mm.

The minimum curve angle that meets this requirement is:

| Track Radius | Minimum Curve Angle |
|--------------|---------------------|
| 3.0 m        | 18.4°               |

The minimum curve angle can be calculated using the following generalized formula:

$$\text{arcLengthInDegrees} = 2 \times \arcsin\left(\frac{800}{2 \times (\text{nominalTrackRadiusInMm} - 500)}\right)$$

### Placement of Curves with Different Radii

In AR/VS applications, adjacent curved sections may now have different radii, provided each section (or group of same-radius sections) individually satisfies the minimum inner-rail length condition above. There is no longer a requirement to insert a straight section between curves of different radii.

However, if curved sections are not directly adjacent (i.e., separated by a straight run), that straight segment must still be longer than the dolly's 800 mm wheelbase.

### AR/VS Tracking

On a perfect track, the accuracy of the reported virtual position of a dolly on a U-shaped track with a 3 m radius is ±2 mm of XY virtual position error and ±0.15 degrees of virtual orientation (pan) error.





Any error or non-linearity in the radius or the alignment of the tracks will have a significant effect on this.

For example:

- Each 1 mm error in the measured radius of a U-shaped track with a 3 m radius can result in up to 5 mm of virtual position error and 0.05 degrees of virtual pan error
- Each 1 mm of rail elevation difference contributes 3.1 mm of virtual position error perpendicular to the track direction when the S2 lift is at full extension (1558 mm). A VR600 head is assumed in this calculation.

## Payload Design

It is important to plan exactly what components will be installed on the SkyDolly robot(s), and how they will be secured.

For best results, ensure the following:

- **The payload is as light as possible.**  
Lighter payloads result in smoother movement.
- **The payload is as compact as possible and its weight is concentrated near its center.**  
The payload must be balanced in two axes; front to back along the camera cradle, and vertically around the tilt axis.
- **The teleprompter, if used, is light and small.**  
It must be mounted rigidly to prevent unwanted swaying motion. The teleprompter must have no loose or free-moving parts. It must allow the desired range of pan/tilt motion without interfering with the robot or cables. The maximum teleprompter size is 38 cm (15") for the VR100 head, and 48 cm (19") for the VR600 head.

## Barcode Positioning System (BPS)

The Barcode Positioning System (BPS) replaces traditional wiredraw encoders in all SkyDolly models effective July 2024. This transition enhances the precision, reliability, and maintenance of the system.

### Key Specifications

- **Accuracy:** Submillimeter positioning accuracy from 0 to 10,000 meters.
- **Speed:** Control at traverse rates up to 5 millimeters per second.
- **Measurement:** Simultaneous position and speed measurement.
- **Track Layout Flexibility:** Supports straight, curved, mixed-radius, and S-shaped track geometries.

### Environmental Requirements

- **Humidity:** 0% to 90% relative humidity, non-condensing.
- **Lighting:** Avoid direct exposure to intense, direct lighting; ensure consistent lighting conditions.
- **Cleanliness:** Maintain a clean environment; regular cleaning of barcode tape and sensors with a soft cloth and commercial glass cleaner.

### Installation and Mounting

When mounting the BPS unit and installing barcode tape:

- Ensure barcode tape is free of wrinkles and mechanical tension.
- Barcode tapes are available in the following lengths:
  - › 10 meters (Product Code FRO-BPS-TAPE-10)
  - › 20 meters (Product Code FRO-BPS-TAPE-20)
  - › 30 meters (Product Code FRO-BPS-TAPE-30)
  - › 40 meters (Product Code FRO-BPS-TAPE-40)

- › 50 meters (Product Code FRO-BPS-TAPE-50)
- › 70 meters (Product Code FRO-BPS-TAPE-70)

## Maintenance

Routine checks include:

- Regularly inspect barcode tape for wear or damage.
- Clean optical sensors and barcode tape to ensure accurate readings.
- Perform firmware updates as needed via Ross Video customer service.

## Accessories

Ross Video sells a wide range of accessories that are compatible with SkyDolly, including the following:

- **Ethernet-based Collision Avoidance** — Starting with **SmartShell 7.0a**, the legacy Collision Avoidance System has been replaced by an Ethernet-based Collision Avoidance feature, which is now included by default.  
Unlike the Controller Area Network (CAN) based Collision Avoidance, the Ethernet-based system requires no hardware accessories or extra cables, and there are no restrictions on the number of dollies on a track or track length.  
The Ethernet-based system allows robotic dollies to exchange positional data and automatically manage their movement to prevent collisions. For more information on setting up and utilizing the Ethernet-based Collision Avoidance, consult with our Program Managers and see the latest Furio Collision Avoidance Setup Guide (5100DR-012).
- **Collision Avoidance System (Legacy)** — The Collision Avoidance System, now considered a legacy accessory as of SmartShell 7.0a, enabled up to four Furio SE robotic dollies to operate on a single track without risk of colliding.  
To protect two dollies, one FRO-CA kit was required. For three dollies, two FRO-CA kits were required. For four dollies, three FRO-CA kits were required. No more than four dollies could occupy a single track.  
Each kit included one collision avoidance module and associated cables. The system allowed the robotic dollies to exchange positional data. If necessary, the dollies automatically limited their movement to prevent collisions.  
Collision avoidance required additional cabling and conformance to specific track layout requirements. For more information about designing your layout to include collision avoidance, consult with our Program Managers and see the Furio Collision Avoidance Setup Guide (5100DR-012).
- **Spare Parts Kits** — You can order spare parts kits to have readily available in case quick repairs are required.
- **CueScript™ Prompters** — Ross Video sells CueScript™ teleprompter kits that are fully compatible with our robots.
- **Fixed-Height Columns** — These columns mount between the SkyDolly and the Furio robotic head. Longer columns position the camera to lower heights:
  - › **17.8 cm (7")** — FRO-FCO-7-SE (not compatible with use of teleprompter)
  - › **30 cm (12")** — FRO-FCO-12-SE
  - › **76 cm (30")** — FRO-FCO-30-SE
  - › **122 cm (48")** — FRO-FCO-48-SE
- **Furio S2 Robotic Lift** — This two-stage robotic lift mounts between the SkyDolly and the Furio robotic head.

## General Studio Requirements

This section specifies general studio requirements, and includes the following topics:

- “**Environmental Requirements**” on [page 8](#)
- “**Working Space**” on [page 8](#)

- “Lift Equipment” on [page 8](#)

**Note:** Except as otherwise explicitly stated, Ross Video does not provide Ethernet cables, power supply cables, sync reference cables, or video cables. Such cables are selected or custom-made to suit the facility, and are to be provided by the systems integrator or the customer. We strongly recommend that you consult with our Program Managers to plan your cabling layout.

## Environmental Requirements

Robotics equipment must be installed in a suitable environment:

- Equipment should be installed in an indoor location not exposed to moisture.
- Acceptable air temperature range is 0° C to 40° C (32° F to 104° F).
- Acceptable air humidity range is 0% to 90% RH, non-condensing.

## Working Space

Installing a SkyDolly system requires lots of working space where technicians can unpack, assemble, sort, and store parts and tools.

Ideally, the SkyDolly system should be installed in an empty studio with no set elements or other materials present. An empty studio usually provides plenty of working space. Uninterrupted access to an empty studio allows the installation process to be more efficient, and therefore quicker and less expensive.

If the studio is not empty, or if it is to be used for shows during the installation period, additional consultation with Ross Video is required to ensure there is adequate working space and to determine the installation schedule.

Installation requires easy access to all sides of the SkyDolly truss. We strongly recommend that any lighting instruments or other objects near the SkyDolly truss be temporarily removed before the installation period begins.

**IMPORTANT:** No lighting instruments or other objects are to be attached to or suspended from any part of the SkyDolly system. Traditional C-shaped lighting clamps can permanently damage the aluminum SkyDolly truss.

## Lift Equipment

Installing the SkyDolly system requires technicians to handle large and heavy components at heights. A scissor lift is required. The lift must accommodate two persons, with ample working space for maneuvering large and heavy items. Lift capacity must be more than 250 kg (550 lbs).

The lift must have unobstructed access to the floor area beneath the entire length of track. The floor must be level, and capable of supporting the weight of the fully-loaded lift.

If the facility does not own a suitable lift, one can be rented locally. Please co-ordinate lift rental details with Ross Video, to ensure that the lift is adequate and is available when needed.

**Note:** In the unlikely event that a suitable lift cannot be brought into the studio, scaffolding can be used instead. This option is not recommended unless absolutely necessary because it is inefficient and therefore increases commissioning time and expense. Any use of scaffolding requires continuous uninterrupted access to the studio, and necessitates additional safety measures that may prolong the installation period. Please consult Ross Video about the use of scaffolding.

## Power and Networking Requirements

This section describes power and networking requirements for Furio SkyDolly robots.

**IMPORTANT:** All cables that run to a Furio SkyDolly or to a Furio robotic head must contain stranded conductors only. Solid conductors are unacceptable because they are more likely to deteriorate due to robotic movement, causing intermittent data transmission. It is also important to use very light, flexible cables to reduce drag. The minimum bend radius rating for each cable in the bundle that is carried by cable trolleys to the dolly must be 67.5 mm (2.65") or less. The weight of the cable bundle must be no more than 1.5 kg per meter (3 lbs per yard).

### Requirements are as follows:

- One AC power supply cable per dolly, long enough to accommodate the full range of dolly movement.  
The dolly end of the cable must terminate in a C13 female socket connector (IEC/EN 60320-1), which plugs into a C14 male plug connector on the dolly's integrated power bar.  
The dolly accepts voltages between 90 VAC and 250 VAC at 50/60 Hz. Total power consumption per robot is 700 Watts (without lift) or 1300 Watts (with lift). These values are for the robot only, and do not include power for cameras or accessories.  
The power supply circuit must be protected by a 15 A fuse or circuit breaker (for 120 VAC circuits), or an 8 A fuse or circuit breaker (for 240 VAC circuits).  
We recommend using a dedicated power supply circuit for each dolly.
- One stranded CAT5E or CAT6E Ethernet network cable per robot, long enough to accommodate the full range of dolly/lift/head movement. One end of the cable connects to the robotics Ethernet network. The other end must terminate in a male RJ45 plug, which connects to a female RJ45 jack on the head.  
The maximum cable distance between the head and a dedicated Ethernet network switch is 100 m (328'). This range can be increased using an Ethernet extender (not provided).
- One sync reference cable per head, terminating in a standard male BNC plug which connects to a standard female BNC socket on the head. This is required only for AR/VS (Augmented Reality and/or Virtual Set) applications.  
AR/VS applications require that the same sync reference signal be delivered to each robot, to each camera, and to the AR/VS graphics rendering system.
- Camera and accessory cables as required, including power cables, video cables, etc. All cables must be long enough to accommodate the full range of dolly/head movement.  
One end of the dolly has an integrated power bar with five female C13 socket connectors (IEC/EN 60320-1). One socket is for powering the dolly (power cable is included). The remaining four sockets are available for powering the camera and accessories.  
Ensure that all equipment plugged into the integrated power bar can accept the same AC voltage supplied to the dolly. Ensure that the total power load, including the robot, camera, and all accessories, does not exceed the supply circuit capacity.  
The dolly comes with an assortment of male/female C14/C13 cables which can be used to power the camera and accessories.  
The dolly motor and lift (if equipped) are powered directly through the dolly without additional power cables. A special power cable is included for connecting the head to the dolly. This cable can be used with a VR100 head or a VR600 head.

## Technical Requirements for the Suspended Track System

The suspended track system consists of a set of dolly rails (2) and safety rails (2) fastened below a dedicated SkyDolly truss by rail support frames spaced approximately one per meter apart.



This section describes technical requirements related to SkyDolly truss and track components, and includes the following topics:

- “**Installation and Maintenance Responsibilities**” on [page 10](#)
- “**Track Description**” on [page 10](#)
- “**Lateral Horizontal Footprint**” on [page 12](#)
- “**Minimum Vertical Envelope**” on [page 14](#)
- “**Estimating Cable Lengths**” on [page 35](#)
- “**Anchor Point Spacing and Loads**” on [page 36](#)
- “**Maximum Force Due to Robot Movement**” on [page 41](#)
- “**SkyDolly Truss Mounting Requirements**” on [page 41](#)

## Installation and Maintenance Responsibilities

The customer or systems integrator installs the SkyDolly truss. Ross Video installs the rail support frames, rails, and all other SkyDolly components.

The SkyDolly truss must be installed such that it meets the load requirements of the SkyDolly system and all other requirements specified in this document, as well as meeting all applicable structural and safety regulations. We strongly recommend that customers hire a professional engineering firm to ensure safe and legal installation of the SkyDolly truss.

To ensure optimal performance, safety, and warranty compliance, periodic inspection and maintenance of SkyDolly truss and track components is required. For more information about required inspection and maintenance tasks, see ***Technical Manual for Furio SkyDolly (5100DR-074-xx)***.

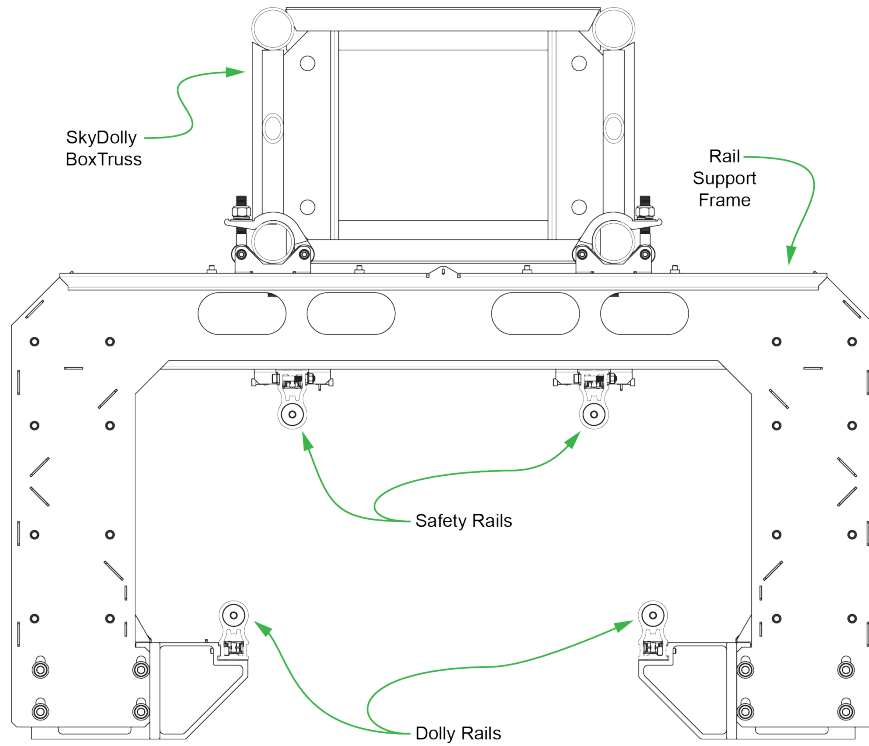
For more information about customer responsibilities, see the document, “ROSS VIDEO WORLDWIDE TERMS AND CONDITIONS OF SALE”, including “ADDENDUM FOR OVERHEAD CAMERA MOTION SYSTEMS”.

## Track Description

[Figure 1](#) shows an end view of the Furio SkyDolly suspended track system with a box truss, and [Figure 2](#) shows the same view with a ladder truss.



**Figure 1 - Furio SkyDolly Suspended Track (end view) - Box Truss**



**Figure 2 - Furio SkyDolly Suspended Track (end view) - Ladder Truss**

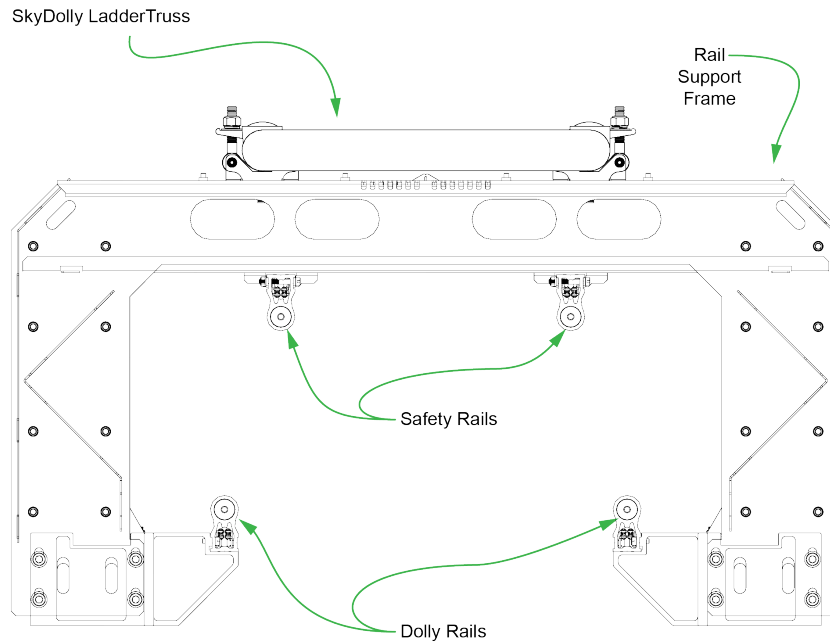
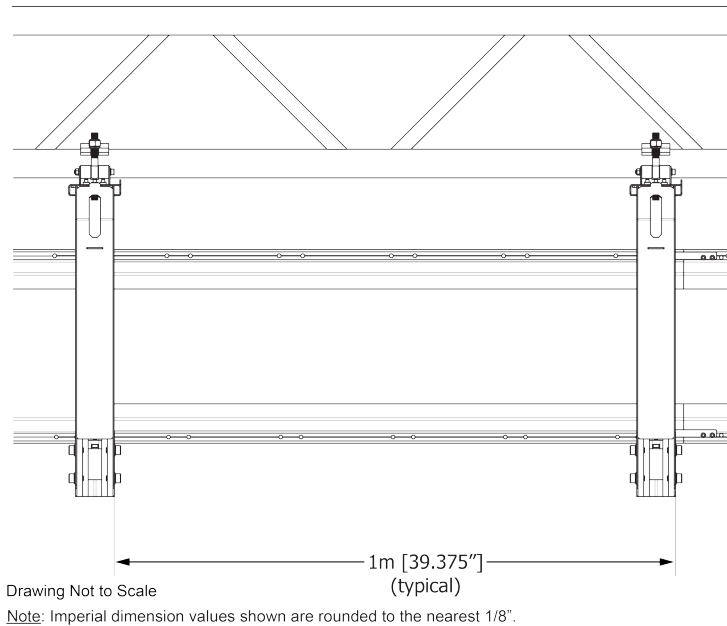
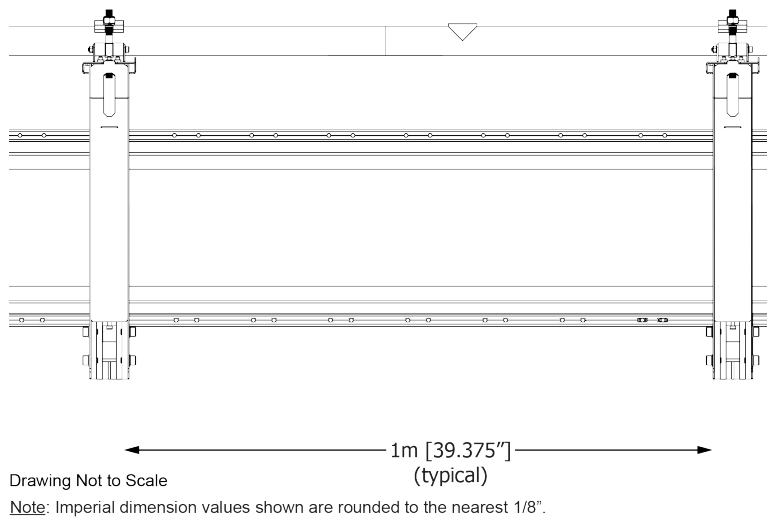


Figure 3 shows a side view of the Furio SkyDolly suspended track system with a box truss, and Figure 4 shows the same view with a ladder truss.

**Figure 3 - Furio SkyDolly Suspended Track (side view) - Box Truss**



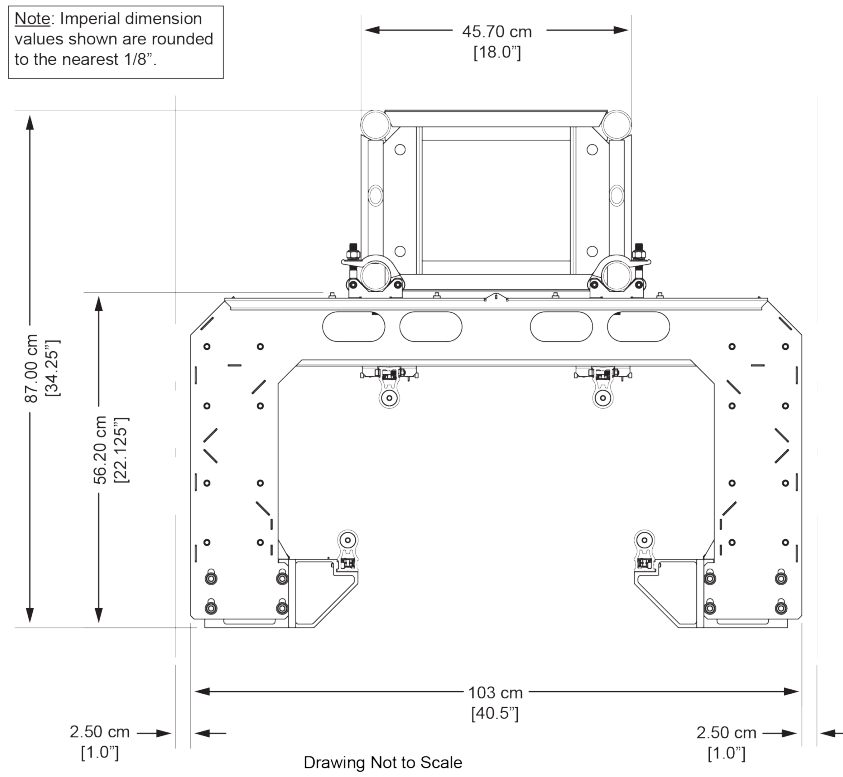
**Figure 4 - Furio SkyDolly Suspended Track (side view) - Ladder Truss**



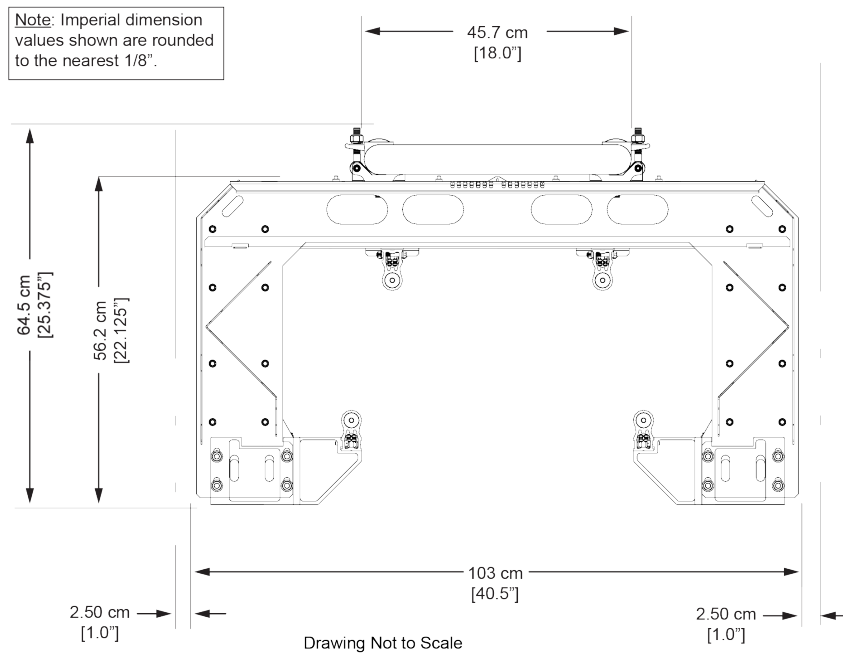
## Lateral Horizontal Footprint

The Track System has a lateral horizontal footprint of 1.03 m (40.5"), and requires a minimum clearance of 2.5 cm (1") on all sides (see Figure 5 with the box truss and Figure 6 with the ladder truss).

**Figure 5 - Furio SkyDolly Suspended Track (end view) - Box Truss**



**Figure 6 - Furio SkyDolly Suspended Track (end view) - Ladder Truss**





## Minimum Vertical Envelope

The track has a minimum vertical envelope of 88 cm (34.6") from the top of the SkyDolly truss to the bottom of the rail support frames. However, the head travels below the track system and is mounted to the dolly via either a fixed-height column or a Furio S2 robotic lift.

The overall minimum vertical envelope varies depending on whether the system has a Furio S2 robotic lift or a fixed-height column, and which Furio robotic pan/tilt head is installed.

**For more information, see:**

- “Minimum Vertical Envelope with Fixed-Height Column and X350 Pan/Tilt Head:” on [page 14](#)
- “Minimum Vertical Envelope with Fixed-Height Column and VR600 Pan/Tilt Head:” on [page 17](#)
- “Minimum Vertical Envelope with Fixed-Height Column and VR100 Pan/Tilt Head:” on [page 19](#)
- “Minimum Vertical Envelope with Furio S2 Lift and X350 Pan/Tilt Head:” on [page 22](#)
- “Minimum Vertical Envelope with Furio S2 Lift and VR600 Pan/Tilt Head:” on [page 26](#)
- “Minimum Vertical Envelope with Furio S2 Lift and VR100 Pan/Tilt Head:” on [page 30](#)

### Minimum Vertical Envelope with Fixed-Height Column and X350 Pan/Tilt Head:

Minimum 15 cm (5.9") clearance below the head is recommended. This does not include clearance for the payload installed on the head.

Fixed-height columns are available in various lengths, which affects the vertical envelope of the system. For a list of column lengths, see “**Accessories**” on [page 7](#).

**Note:** If you plan to attach a teleprompter to the SkyDolly, a 30.5 cm (12") fixed-height column (or longer) is required.

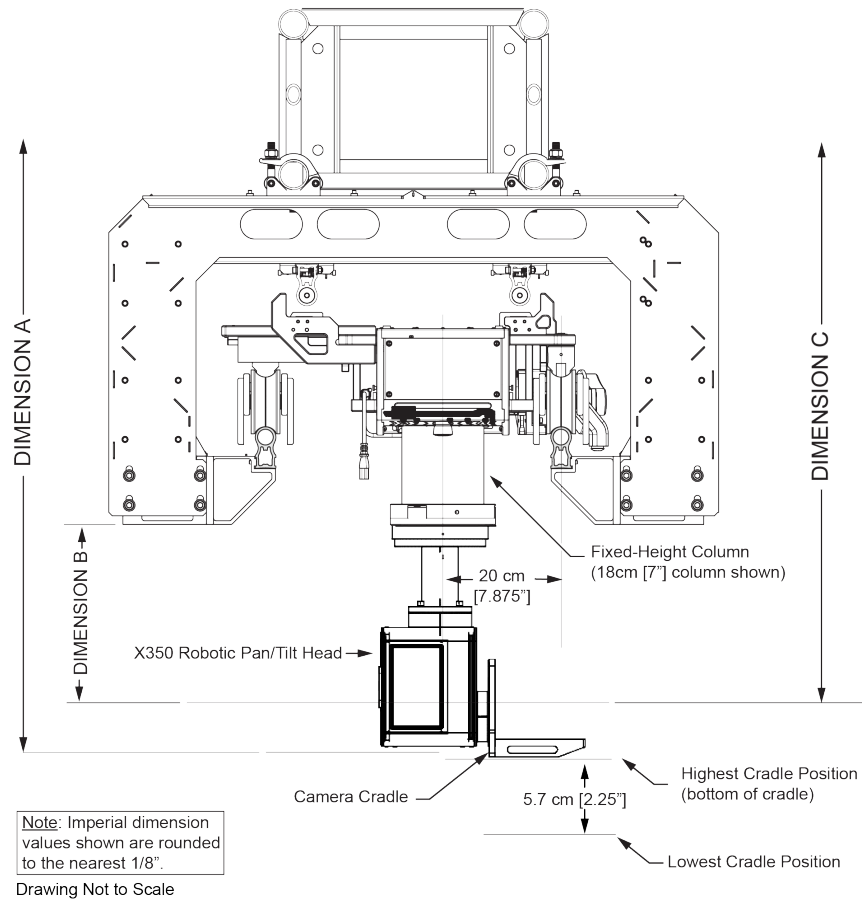
[Figure 7](#) shows the vertical envelope with a ladder truss configuration for a SkyDolly camera system with fixed-height column and X350 head.

**Table 2** on [page 15](#) provides values for dimensions **A**, **B**, and **C** based on various fixed column lengths. The drawing shows the system with a 17.8 cm (7") fixed-height column.

**Figure 8** on [page 16](#) and **Table 3** on [page 16](#) provide similar values, but for with ladder truss configuration.



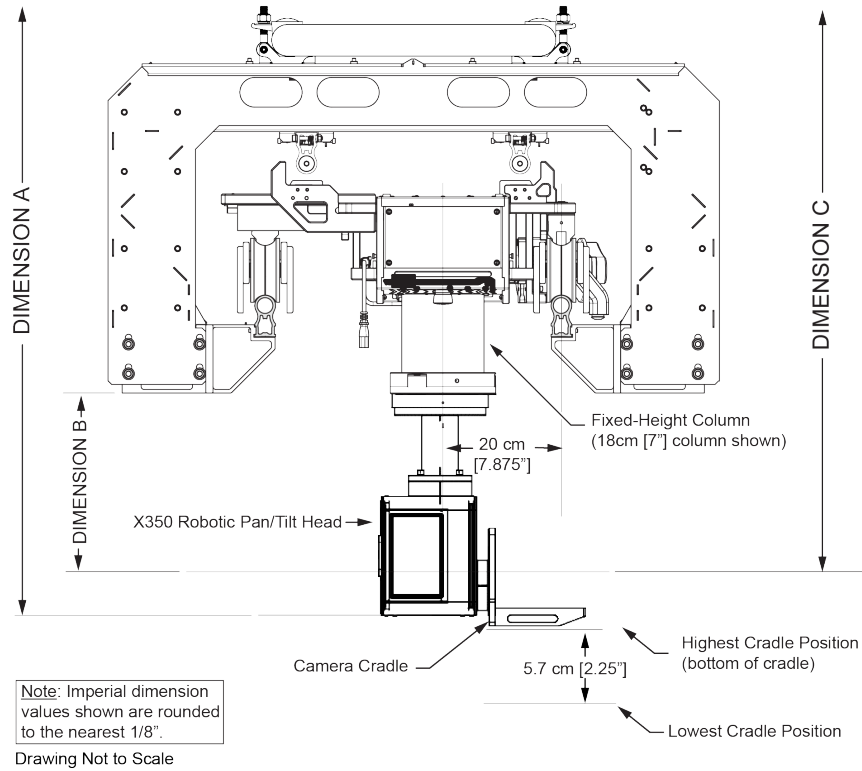
**Figure 7 - Vertical Envelope for Furio SkyDolly with Furio X350 Robotic Pan/Tilt Head - Box Truss**



**Table 2 - Vertical Envelope Dimensions for Furio SkyDolly with X350 Robotic Pan/Tilt**

|   | Column Length         |                      |                      |                       |
|---|-----------------------|----------------------|----------------------|-----------------------|
|   | 17.8 cm [7"]          | 30.5 cm [12"]        | 76.2 cm [30"]        | 121.9 cm [48"]        |
| <b>DIMENSION A</b><br>Total minimum vertical envelope, not including camera cradle or payload | 118.2 cm<br>[46.5"]   | 130.2 cm<br>[51.25"] | 176.4 cm<br>[69.5"]  | 222.2 cm<br>[87.48"]  |
| <b>DIMENSION B</b><br>Distance from bottom of rail support frame to center of tilt axis       | 27.0 cm<br>[10.625"]  | 39.0 cm<br>[15.375"] | 85.2 cm<br>[33.5"]   | 131.1 cm<br>[51.625"] |
| <b>DIMENSION C</b><br>Distance from top of SkyDolly box to center of tilt axis                | 113.9 cm<br>[44.875"] | 125.9 cm<br>[49.5"]  | 172.1 cm<br>[67.75"] | 218.0 cm<br>[85.875"] |

**Figure 8 - Vertical Envelope for Furio SkyDolly with X350 Robotic Pan/Tilt Head - Ladder Truss**



**Table 3 - Vertical Envelope Dimensions for Furio SkyDolly with X350 Robotic Pan/Tilt**

|   | Column Length        |                       |                       |                       |
|---|----------------------|-----------------------|-----------------------|-----------------------|
|   | 17.8 cm [7"]         | 30.5 cm [12"]         | 76.2 cm [30"]         | 121.9 cm [48"]        |
| <b>DIMENSION A</b><br>Total minimum vertical envelope, not including camera cradle or payload | 95.4 cm<br>[37.5"]   | 107.5 cm<br>[42.375"] | 153.7 cm<br>[60.5"]   | 199.6 cm<br>[78.5"]   |
| <b>DIMENSION B</b><br>Distance from bottom of rail support frame to center of tilt axis       | 26.8 cm<br>[10.5"]   | 38.7 cm<br>[15.25"]   | 85.0 cm<br>[33.5"]    | 130.8 cm<br>[51.5"]   |
| <b>DIMENSION C</b><br>Distance from top of SkyDolly ladder truss to center of tilt axis       | 91.2 cm<br>[35.875"] | 103.2 cm<br>[40.625"] | 149.4 cm<br>[58.875"] | 195.3 cm<br>[76.875"] |

**Minimum Vertical Envelope with Fixed-Height Column and VR600 Pan/Tilt Head:**

Minimum 15 cm (5.9") clearance below the head is recommended. This does not include clearance for the payload installed on the head.

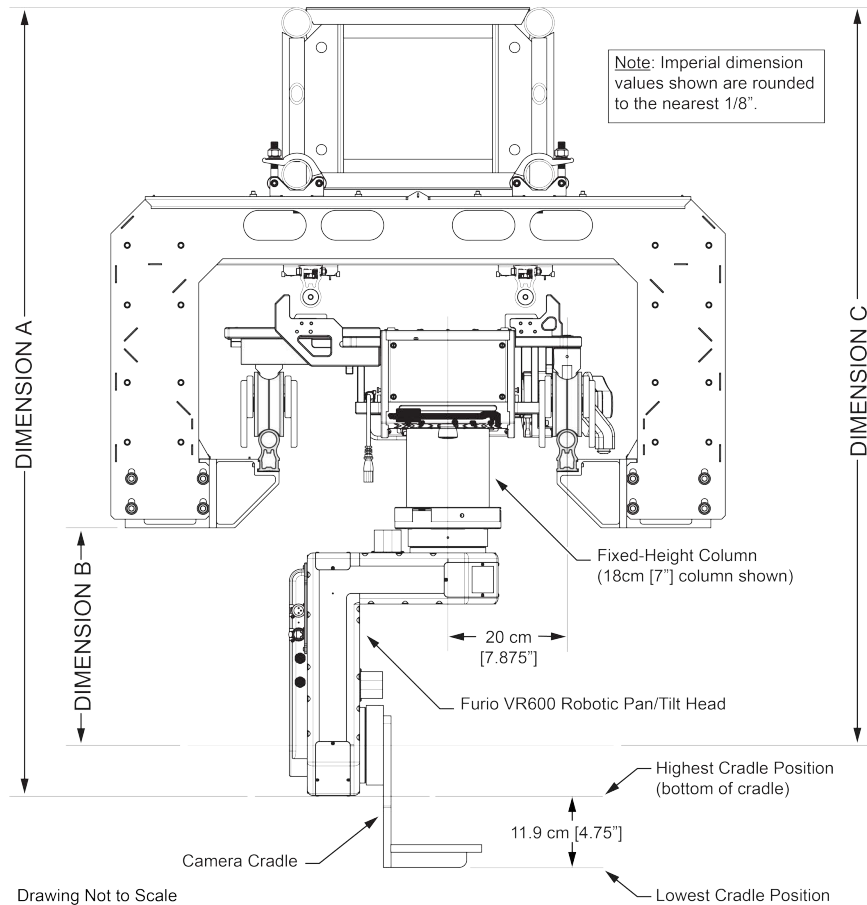
Fixed-height columns are available in various lengths, which affects the vertical envelope of the system. For a list of column lengths, see "Accessories" on [page 7](#).

**Note:** If you plan to attach a teleprompter to the SkyDolly, a 30.5 cm (12") fixed-height column (or longer) is required.

[Figure 9](#) shows the vertical envelope for a SkyDolly camera system with fixed-height column and VR600 head with box truss configuration. **Table 4** on [page 18](#) provides values for dimensions **A**, **B**, and **C** based on various fixed column lengths. The drawing shows the system with a 17.8 cm (7") fixed-height column.

**Figure 10** on [page 18](#) and **Table 5** on [page 19](#) provide similar values, but for with ladder truss configuration.

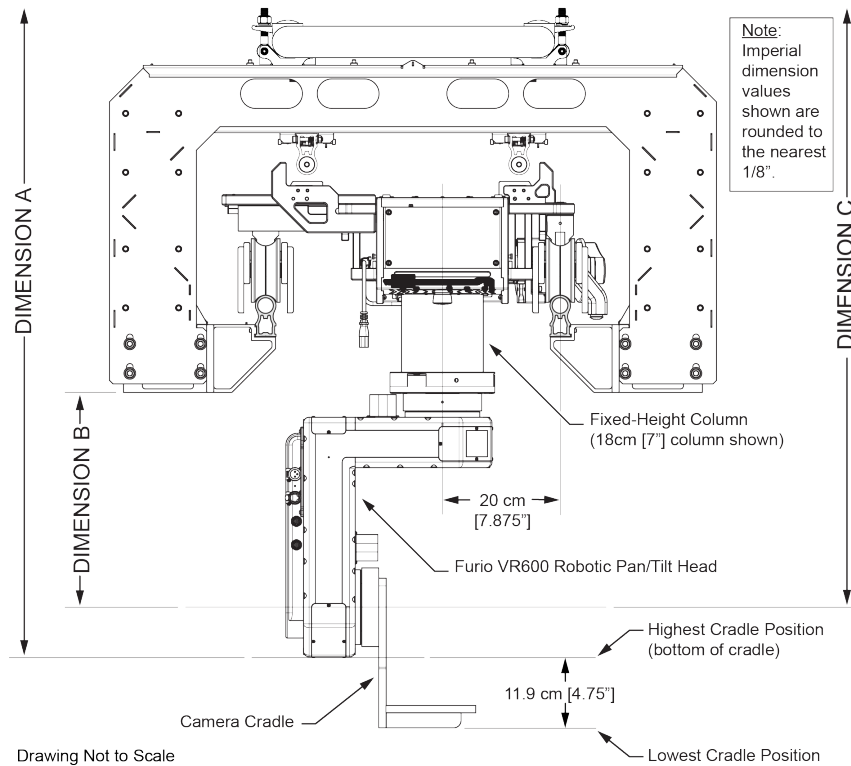
**Figure 9 - Vertical Envelope for Furio SkyDolly with Furio VR600 Robotic Pan/Tilt Head - Box Truss**



**Table 4 - Vertical Envelope Dimensions for Furio SkyDolly with Furio VR600 Robotic Pan/Tilt Head - Box Truss**

|   | Column Length      |                    |                    |                    |
|---|--------------------|--------------------|--------------------|--------------------|
|   | 17.8 cm [7"]       | 30.5 cm [12"]      | 76.2 cm [30"]      | 121.9 cm [48"]     |
| <b>DIMENSION A</b><br>Total minimum vertical envelope, not including camera cradle or payload | 131.8 cm [51.875"] | 144.0 cm [56.625"] | 190.0 cm [74.75"]  | 236.0 cm [92.875"] |
| <b>DIMENSION B</b><br>Distance from bottom of rail support frame to center of tilt axis       | 36.3 cm [14.25"]   | 48.5 cm [19.0"]    | 94.5 cm [37.25"]   | 140.5 cm [55.375"] |
| <b>DIMENSION C</b><br>Distance from top of SkyDolly box truss to center of tilt axis          | 123.3 cm [48.5"]   | 135.4 cm [53.375"] | 181.4 cm [71.375"] | 227.4 cm [89.5"]   |

**Figure 10 - Vertical Envelope for Furio SkyDolly with Furio VR600 Robotic Pan/Tilt Head - Box Truss**



Drawing Not to Scale

**Table 5 - Vertical Envelope Dimensions for Furio SkyDolly with Furio VR600 Robotic Pan/Tilt Head - Ladder Truss**

|   | Column Length         |                       |                       |                       |
|---|-----------------------|-----------------------|-----------------------|-----------------------|
|   | 17.8 cm [7"]          | 30.5 cm [12"]         | 76.2 cm [30"]         | 121.9 cm [48"]        |
| <b>DIMENSION A</b><br>Total minimum vertical envelope, not including camera cradle or payload | 109.3 cm<br>[43.0"]   | 121.5 cm<br>[47.875"] | 167.5 cm<br>[66.0"]   | 213.5 cm<br>[84.0"]   |
| <b>DIMENSION B</b><br>Distance from bottom of rail support frame to center of tilt axis       | 36.3 cm<br>[14.25"]   | 48.5 cm<br>[19.125"]  | 94.5 cm<br>[37.25"]   | 140.5 cm<br>[55.375"] |
| <b>DIMENSION C</b><br>Distance from top of SkyDolly ladder truss to center of tilt axis       | 100.8 cm<br>[39.625"] | 113.0 cm<br>[44.5"]   | 159.0 cm<br>[62.625"] | 205.0 cm<br>[80.750"] |

### Minimum Vertical Envelope with Fixed-Height Column and VR100 Pan/Tilt Head:

Minimum 15 cm (5.9") clearance below the head is recommended. This does not include clearance for the payload installed on the head.

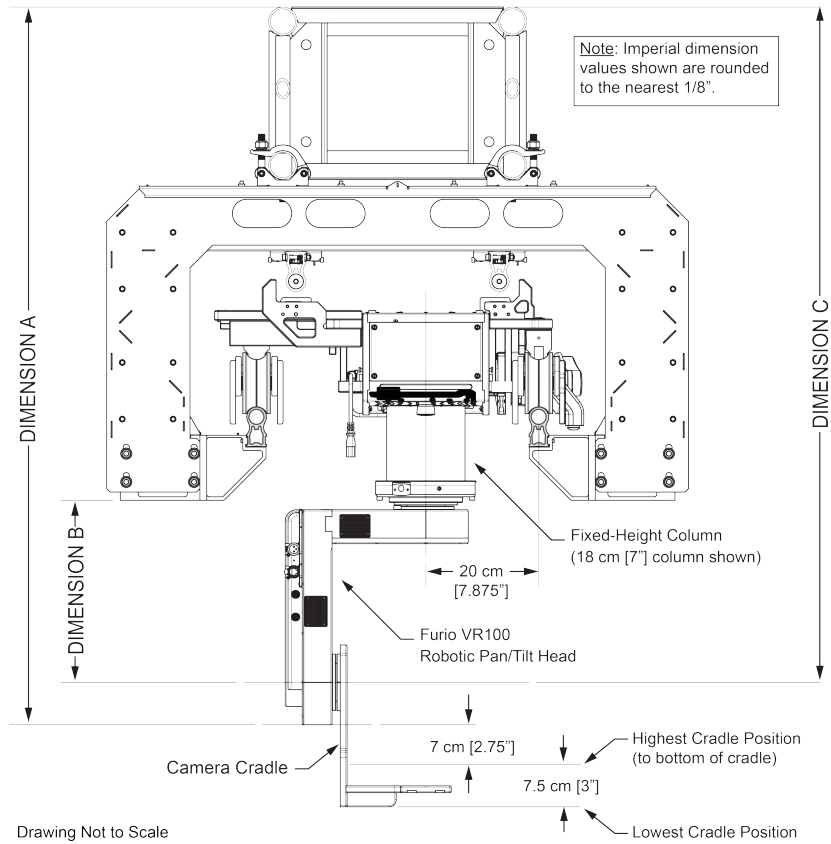
Fixed-height columns are available in various lengths, which affects the vertical envelope of the system. For a list of column lengths, see **"Accessories"** on [page 7](#).

**Note:** If you plan to attach a teleprompter to the SkyDolly, a 30.5 cm (12") fixed-height column (or longer) is required.

**Figure 11** on [page 20](#) shows the vertical envelope for a SkyDolly camera system with a fixed-height column and VR100 head with the box truss configuration. **Table 6** on [page 20](#) provides values for dimensions **A**, **B**, and **C** based on various fixed column lengths. The drawing shows the system with a 17.8 cm (7") column.

**Figure 12** on [page 21](#) and **Table 7** on [page 21](#) provide similar values, but for with ladder truss configuration.

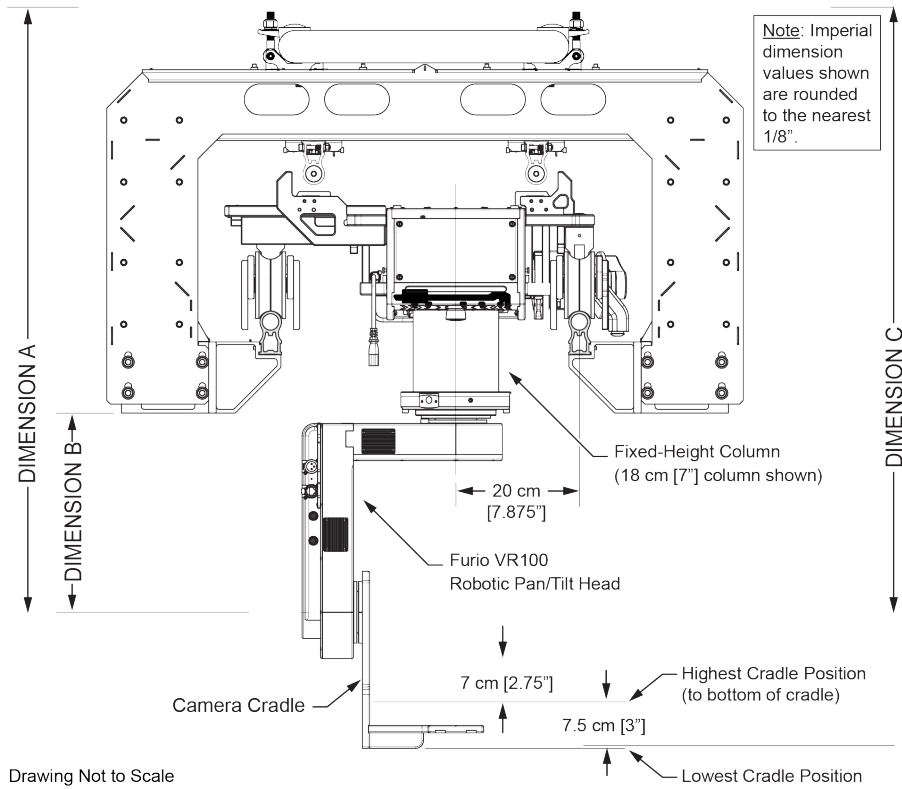
**Figure 11 - Vertical Envelope of Furio SkyDolly with Furio VR100 Robotic Pan/Tilt Head - Box Truss**



**Table 6 - Vertical Envelope Dimensions for Furio SkyDolly with Furio VR100 Robotic Pan/Tilt Head - BoxTruss**

|  | Column Length     |                   |                    |                    |
|--|-------------------|-------------------|--------------------|--------------------|
|  | 17.8 cm [7"]      | 30.5 cm [12"]     | 76.2 cm [30"]      | 121.9 cm [48"]     |
| DIMENSION A<br>Total minimum vertical envelope, not including camera cradle or payload | 127 cm [50.0"]    | 139. cm [55.0"]   | 185.0 cm [72.875"] | 231.1 cm [91.0"]   |
| DIMENSION B<br>Distance from bottom of rail support frame to center of tilt axis       | 32.2 cm [12.625"] | 44.9 cm [17.625"] | 90.6 cm [35.625"]  | 136.3 cm [53.625"] |
| DIMENSION C<br>Distance from top of SkyDolly box truss to center of tilt axis          | 120 cm [47.25"]   | 131.4 cm [51.75"] | 177.4 cm [69.875"] | 223.4 cm [88.0"]   |

**Figure 12 - Vertical Envelope of Furio SkyDolly with Furio VR100 Robotic Pan/Tilt Head - Ladder Truss**



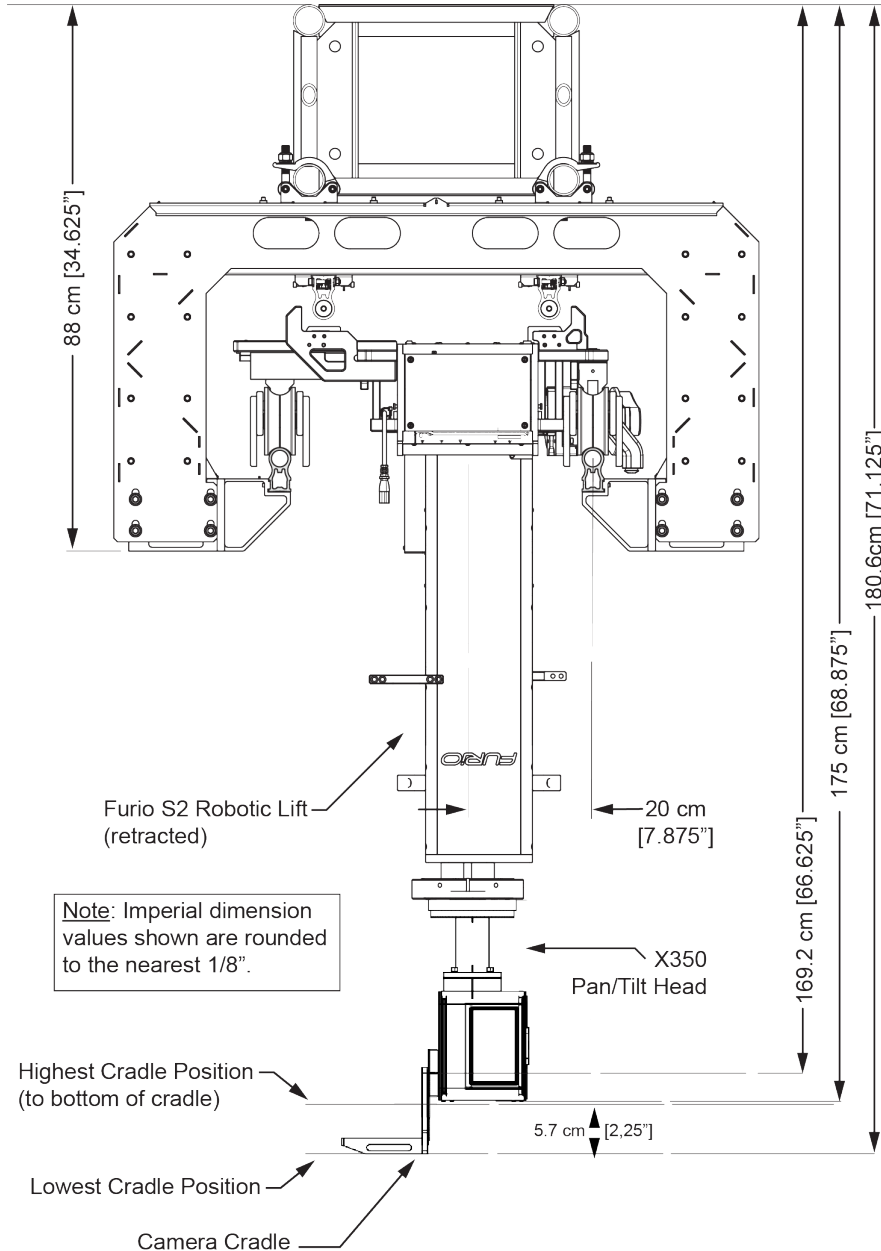
**Table 7 - Vertical Envelope Dimensions for Furio SkyDolly with Furio VR100 Robotic Pan/Tilt Head - Ladder Truss**

|   | Column Length        |                       |                      |                       |
|---|----------------------|-----------------------|----------------------|-----------------------|
|   | 17.8 cm<br>[7"]      | 30.5 cm<br>[12"]      | 76.2 cm<br>[30"]     | 121.9 cm<br>[48"]     |
| <b>DIMENSION A</b><br>Total minimum vertical envelope, not including camera cradle or payload | 104.3 cm<br>[41.0"]  | 116.5 cm<br>[45.875"] | 162.5 cm<br>[64.0"]  | 208.5 cm<br>[82.0"]   |
| <b>DIMENSION B</b><br>Distance from bottom of rail support frame to center of tilt axis       | 32.3 cm<br>[12.75"]  | 44.7 cm<br>[17.625"]  | 90.5 cm<br>[35.625"] | 136.5 cm<br>[53.75"]  |
| <b>DIMENSION C</b><br>Distance from top of SkyDolly ladder truss to center of tilt axis       | 96.8 cm<br>[38.125"] | 109.0 cm<br>[43.0"]   | 155.0 cm<br>[61.0"]  | 201.0 cm<br>[79.125"] |

**Minimum Vertical Envelope with Furio S2 Lift and X350 Pan/Tilt Head:**

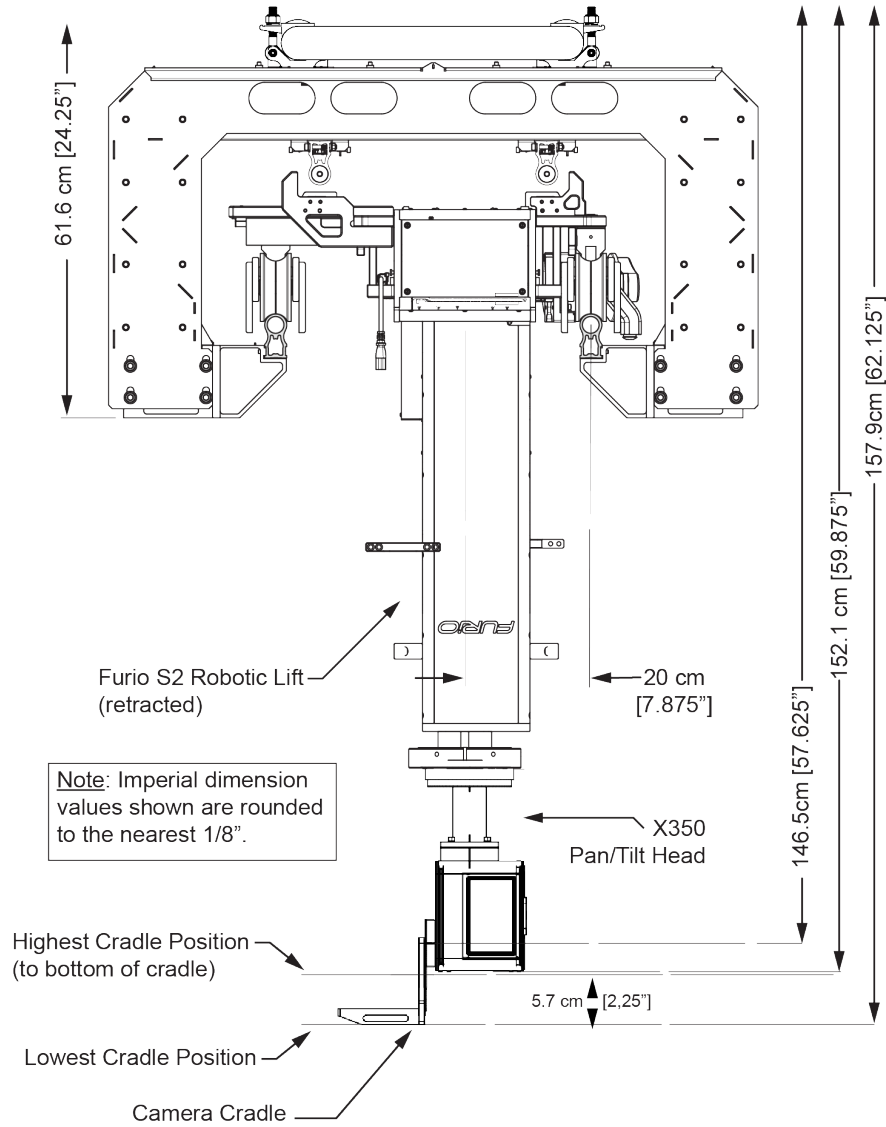
The vertical envelope of SkyDolly with a Furio S2 robotic lift and an X350 head varies depending on the camera cradle position and how far the lift is extended. [Figure 13](#) and [Figure 14](#) show SkyDolly with an X350 head and Furio S2 robotic lift (fully retracted). [Figure 15](#) and [Figure 16](#) show SkyDolly with an X350 head and Furio S2 robotic lift (fully extended).

**Figure 13 - SkyDolly with Furio S2 Robotic Lift (retracted) and X350 Robotic Pan/Tilt Head - Box Truss**



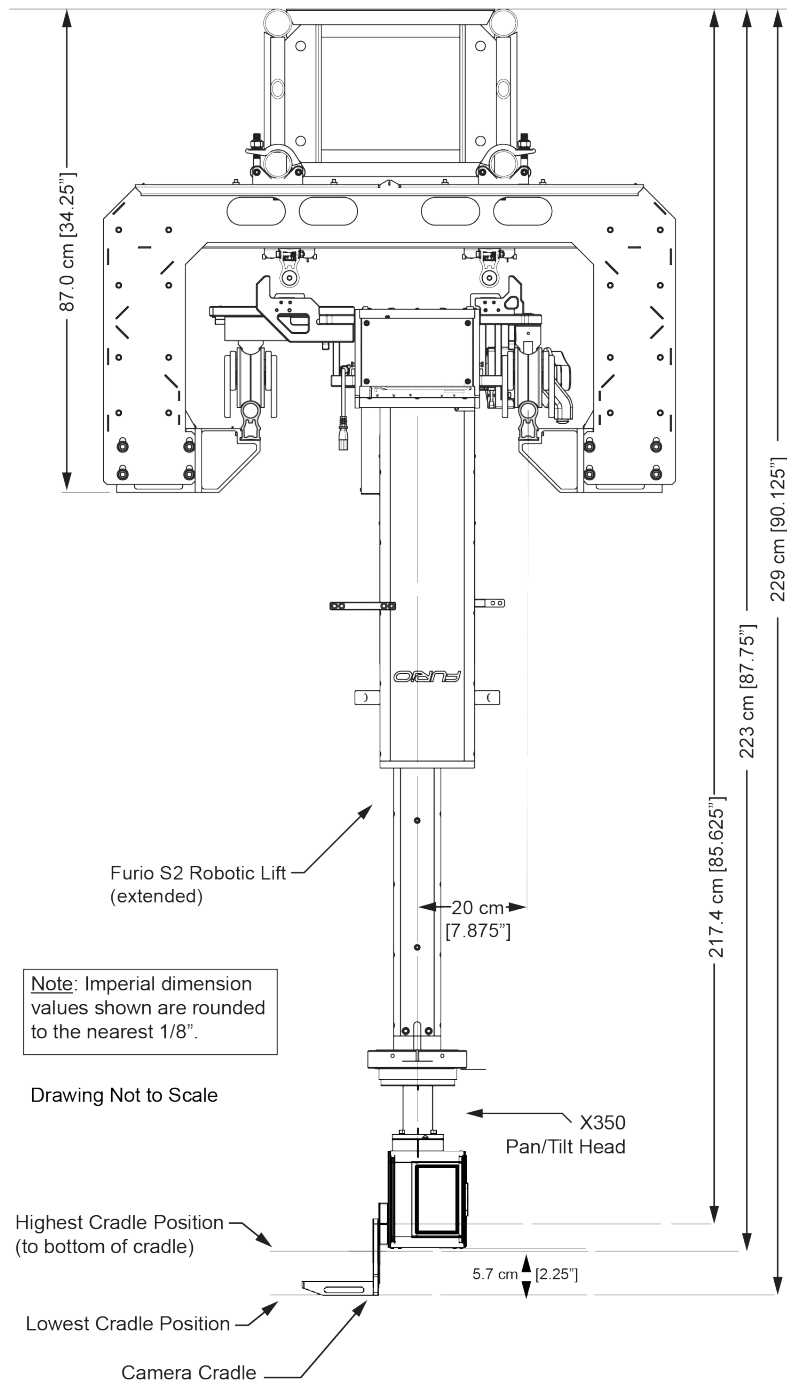
Drawing Not to Scale

**Figure 14 - SkyDolly with Furio S2 Robotic Lift (retracted) and X350 Robotic Pan/Tilt Head - Ladder Truss**

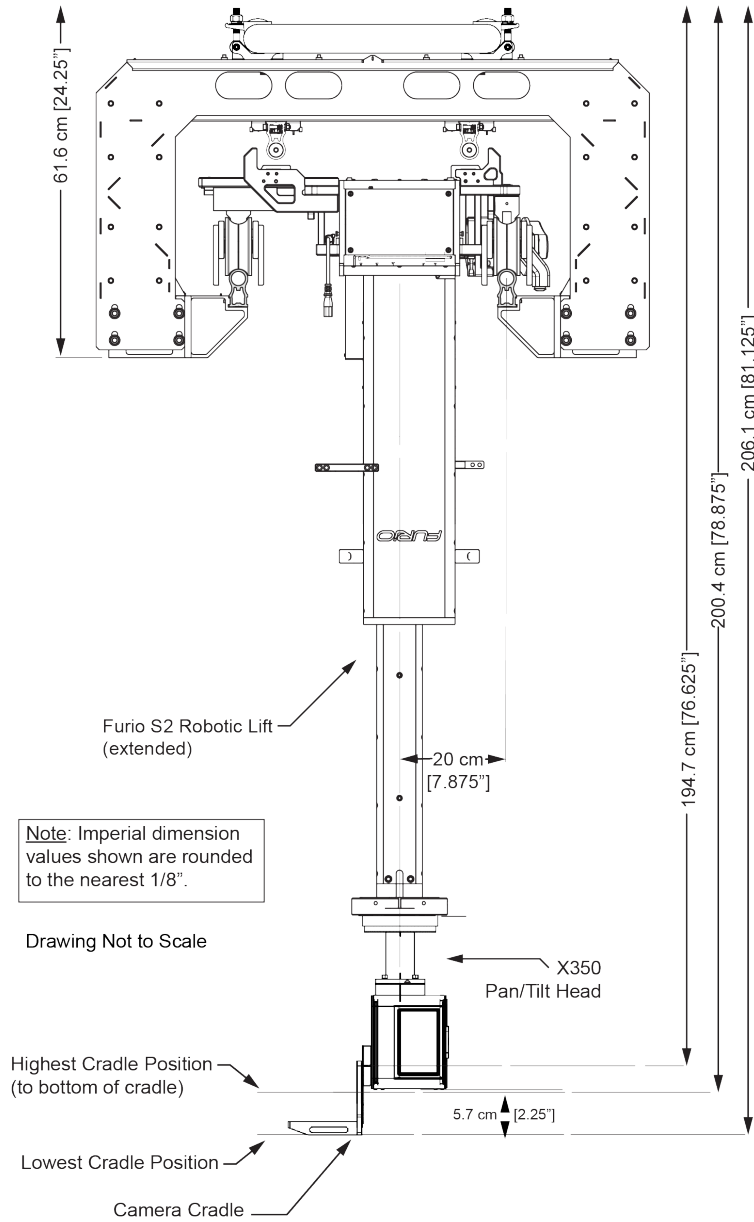


Drawing Not to Scale

**Figure 15 - SkyDolly with Furio S2 Robotic Lift (extended) and Furio X350 Robotic Pan/Tilt Head - Box Truss**



**Figure 16 - SkyDolly with Furio S2 Robotic Lift (extended) and X350 Robotic Pan/Tilt Head - Ladder Truss**





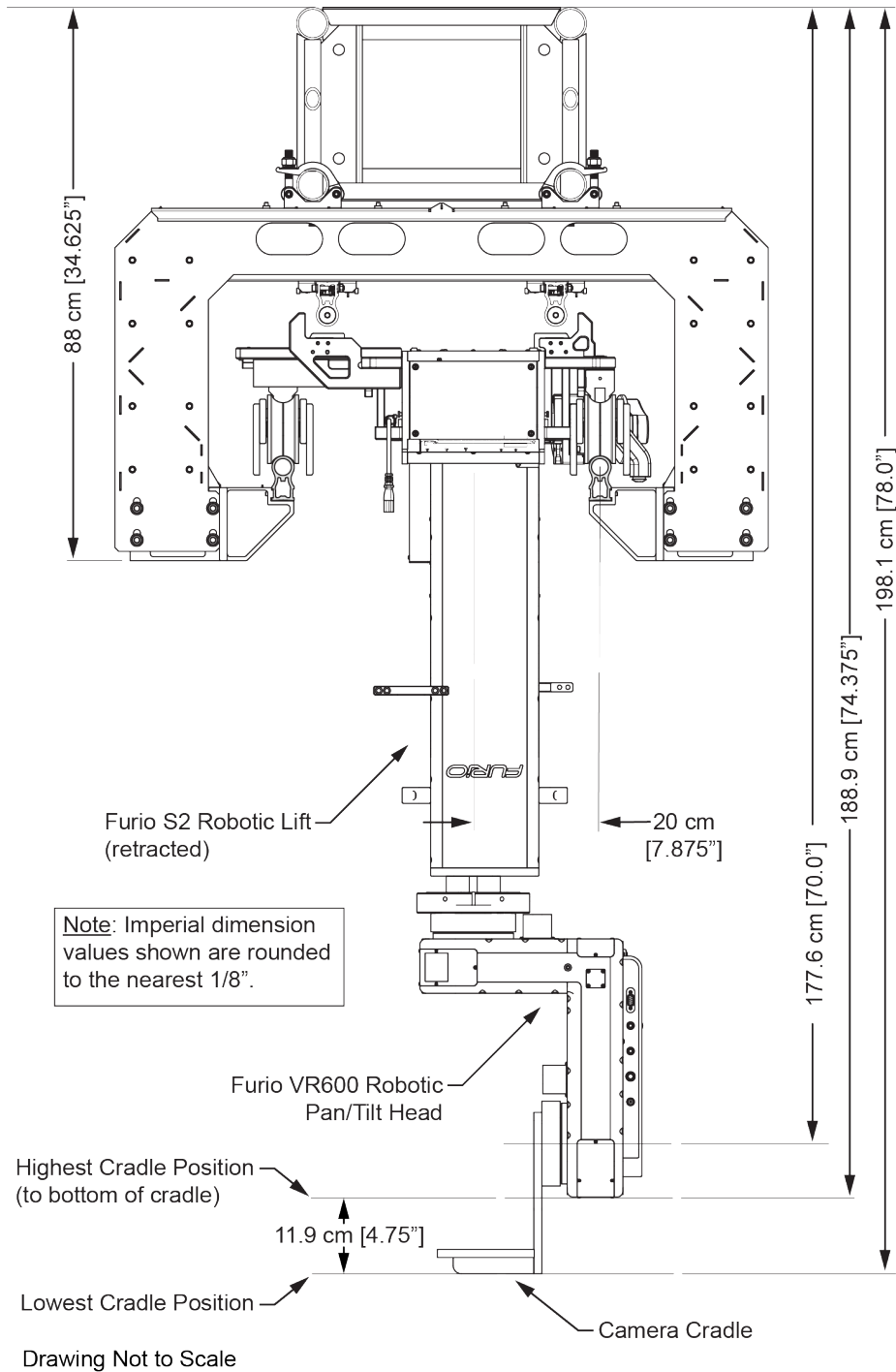
### Minimum Vertical Envelope with Furio S2 Lift and VR600 Pan/Tilt Head:

The vertical envelope of SkyDolly with a Furio S2 robotic lift and a VR600 head varies depending on the camera cradle position and how far the lift is extended.

[Figure 17](#) and [Figure 18](#) show SkyDolly with a VR600 head and Furio S2 robotic lift (fully retracted).



**Figure 17 - SkyDolly with Furio S2 Robotic Lift (retracted) and Furio VR600 Robotic Pan/Tilt Head - Box Truss**



**Figure 18 - SkyDolly with Furio S2 Robotic Lift (retracted) and Furio VR600 Robotic Pan/Tilt Head - Ladder Truss**

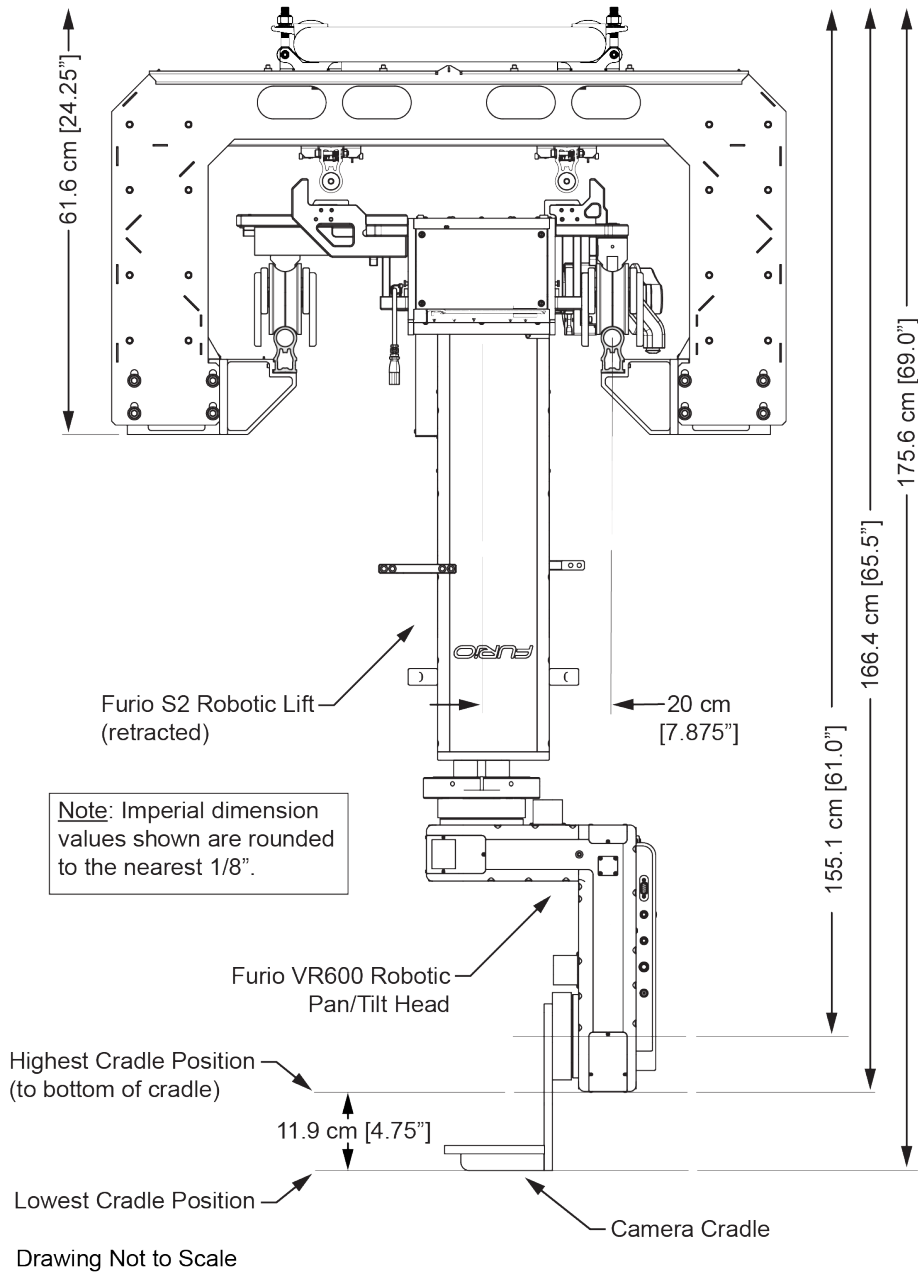
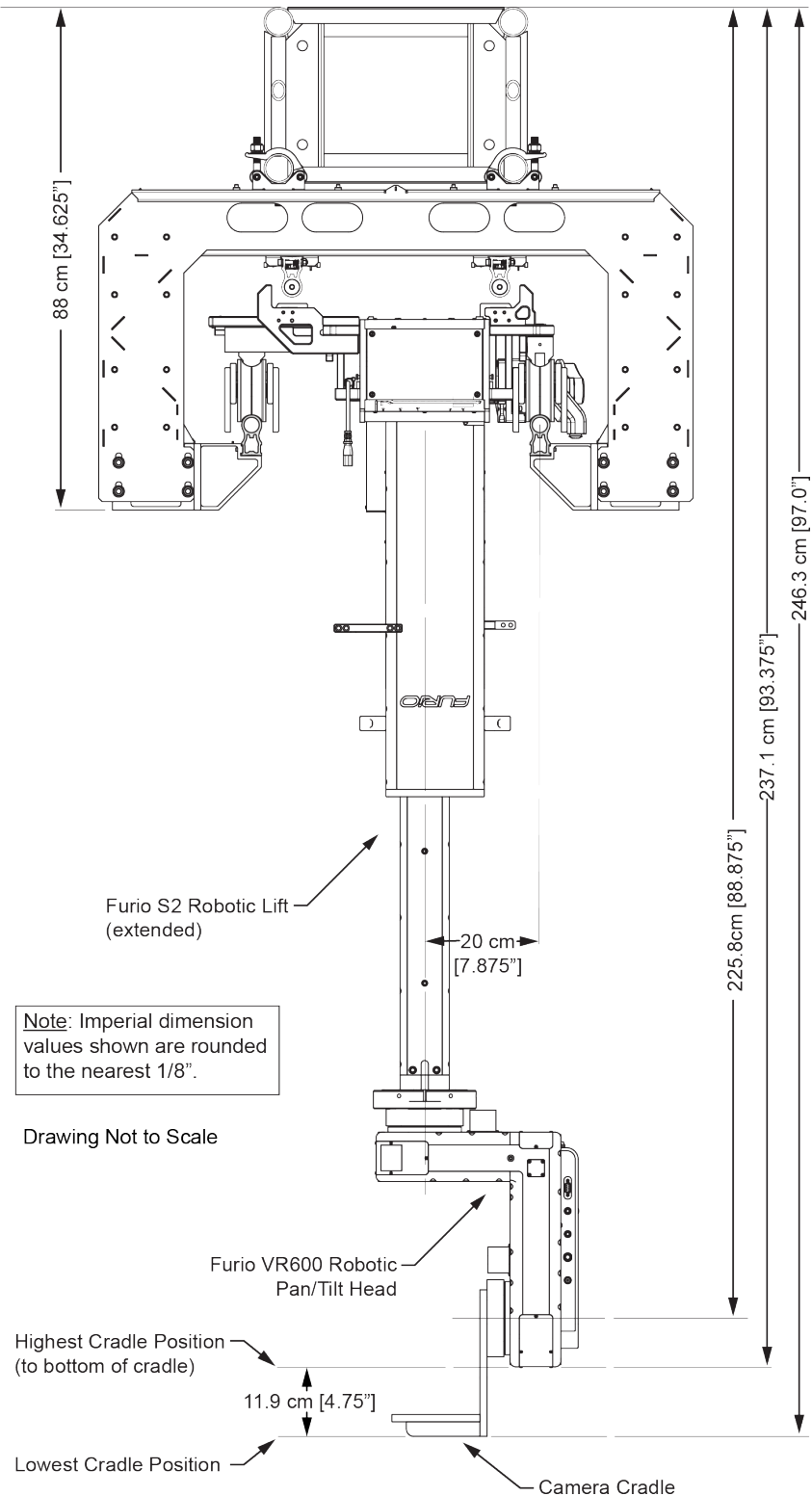
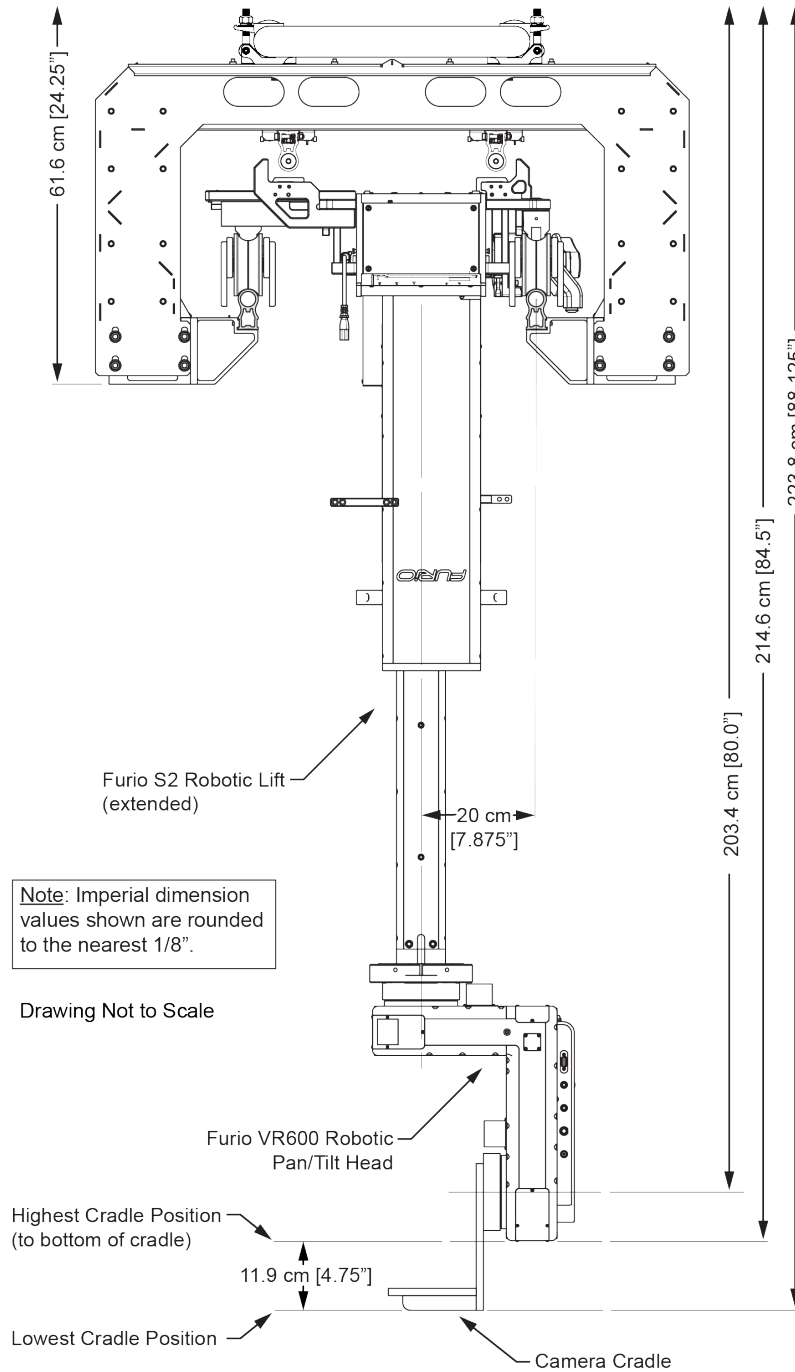


Figure 19 and Figure 20 show SkyDolly with a VR600 head and Furio S2 robotic lift (fully extended).

**Figure 19 - SkyDolly with Furio S2 Robotic Lift (extended) and Furio VR600 Robotic Pan/Tilt Head - Box Truss**



**Figure 20 - SkyDolly with Furio S2 Robotic Lift (extended) and Furio VR600 Robotic Pan/Tilt Head - Ladder Truss**

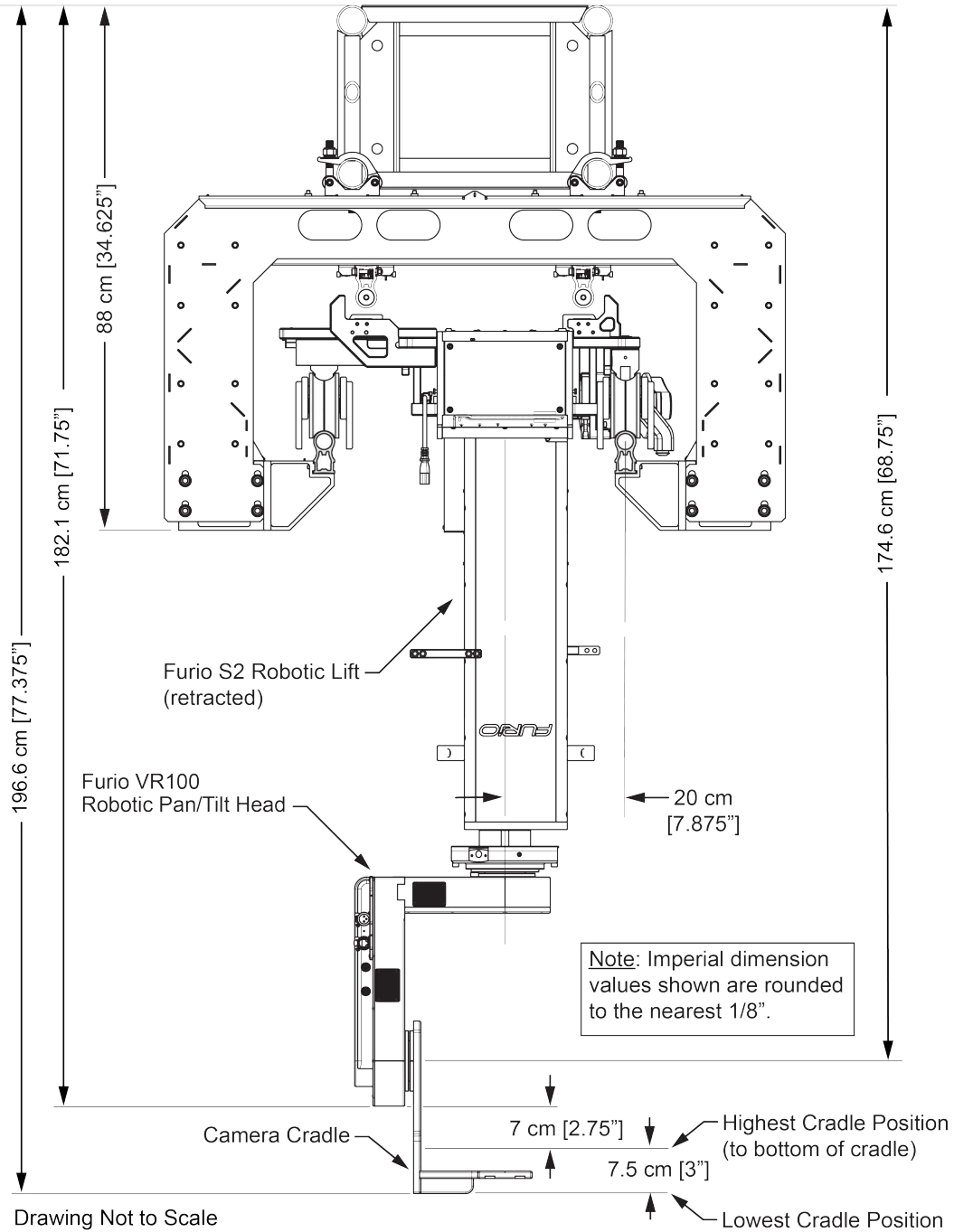


**Minimum Vertical Envelope with Furio S2 Lift and VR100 Pan/Tilt Head:**

The vertical envelope of SkyDolly with a Furio S2 robotic lift and a VR100 head varies depending on the camera cradle position and how far the lift is extended.

Figure 21 and Figure 22 show SkyDolly with a VR100 head and Furio S2 robotic lift (fully retracted).

**Figure 21 - SkyDolly with Furio S2 Robotic Lift (retracted) and Furio VR100 Robotic Pan/Tilt Head - Box Truss**



**Figure 22 - SkyDolly with Furio S2 Robotic Lift (retracted) and Furio VR100 Robotic Pan/Tilt Head - Ladder Truss**

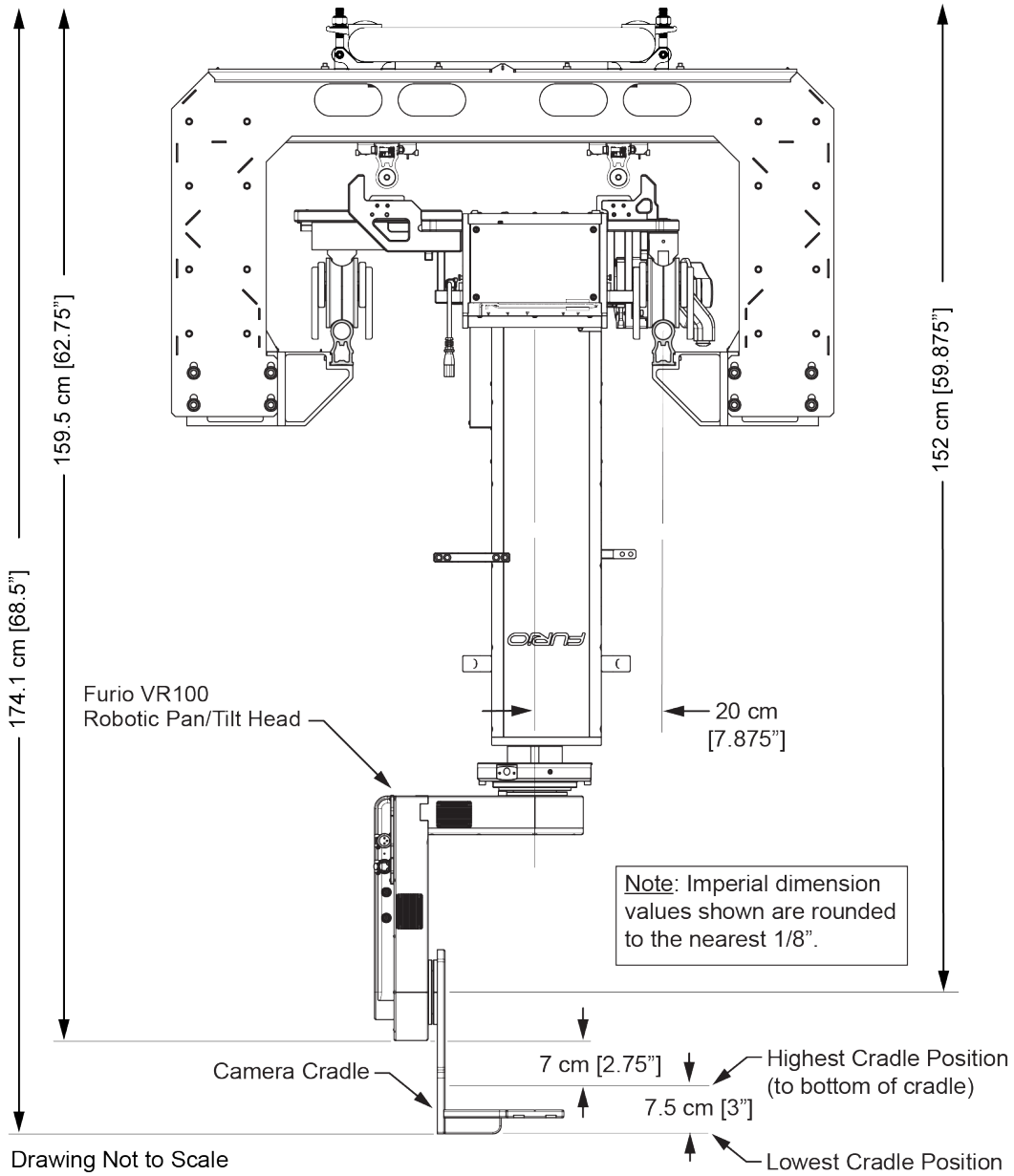
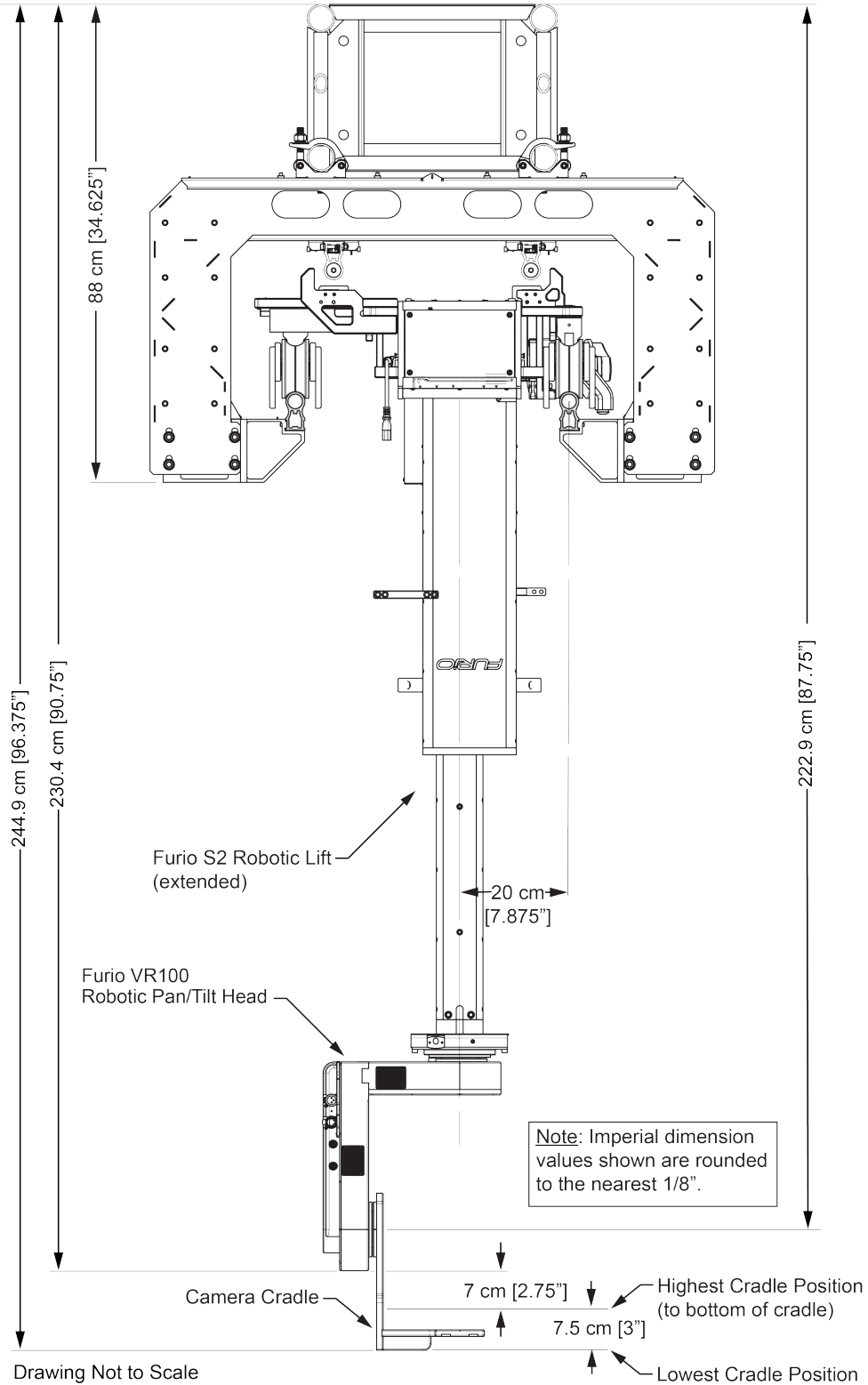
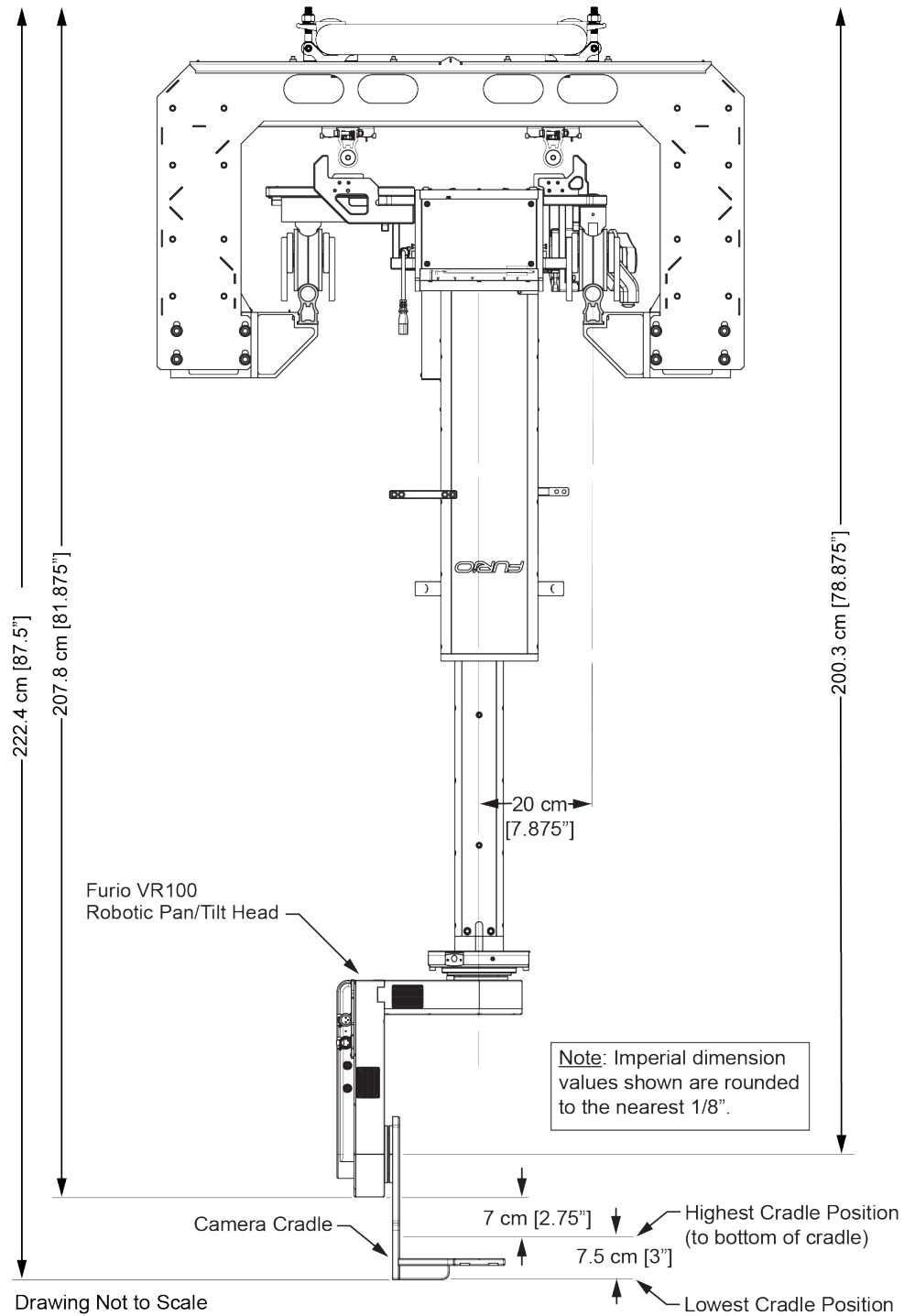


Figure 23 and Figure 24 show SkyDolly with a VR100 head and Furio S2 robotic lift (fully extended).

**Figure 23 - SkyDolly with Furio S2 Robotic Lift (extended) and Furio VR100 Robotic Pan/Tilt Head - Box Truss**



**Figure 24 - SkyDolly with Furio S2 Robotic Lift (extended) and Furio VR100 Robotic Pan/Tilt Head - Ladder Truss**



## Estimating Cable Lengths

We recommend you create custom cables on-site as needed, after the track and dollies are installed. When planning your cables, add extra length to allow the cables to easily reach their destinations on the dolly, robotic head, and payload. Robotic lifts and heads move, and therefore require additional cable slack.

You can estimate the required length of data and power cables that run from the end of the track to the dolly. When calculating cable length, it's important to account for slack introduced by the draping of the cable bundle. Cables are bundled and wrapped, and then fastened to cable trolleys that ride along the safety rails. The bundled cables are also attached to tow cables that run between the cable trolleys.

The safety rails, which run above the dolly rails (see **Figure 1** on [page 11](#)), extend beyond the dolly rails to provide a storage area for cable trolleys and the cable bundle. For the purposes of determining required cable lengths, the **Total Track Length** is considered to be the distance from the farthest point the dolly can access, to the end of the safety rails.

The tow cables ensure that power and data cables are never pulled taut. To ensure that cable bundles do not droop into the field of view of the camera, the length of the tow cables varies depending on the height of the lift or fixed-height column used:

- 17.8 cm (7") fixed-height column — Tow cables are 1.2 m (47.25") long
- 30.5 cm (12") fixed-height column — Tow cables are 1.2 m (47.25") long.
- 76.2 cm (30") fixed-height column — Tow cables are 1.5 m (59") long.
- 121.9 cm (48") fixed-height column — Tow cables are 2.0 m (78.75") long.
- Furio S2 Lift — Tow cables are 2.0 m (78.75") long.

Calculate the length of cable required to span from the end of the track to the dolly, based on the length of the tow cables:

- **For 1.2 m (47.25") tow cables:**

Multiply **Total Track Length** by **1.07** and add **2.0 m (78.75")** for wiredraw and dolly management.

**Note:** The cable length from the dolly base to the robotic head and payload is not included.

- **For 1.5 m (39.375") tow cables:**

Multiply **Total Track Length** by **1.05** and add **2.0 m (78.75")** for wiredraw and dolly management.

**Note:** The cable length from the dolly base to the robotic head and payload is not included.

- **For 2.0 m (70.875") tow cables:**

Multiply **Total Track Length** by **1.03** and add **2.0 m (78.75")** for wiredraw and dolly management.

**Note:** The cable length from the dolly base to the robotic head and payload is not included.

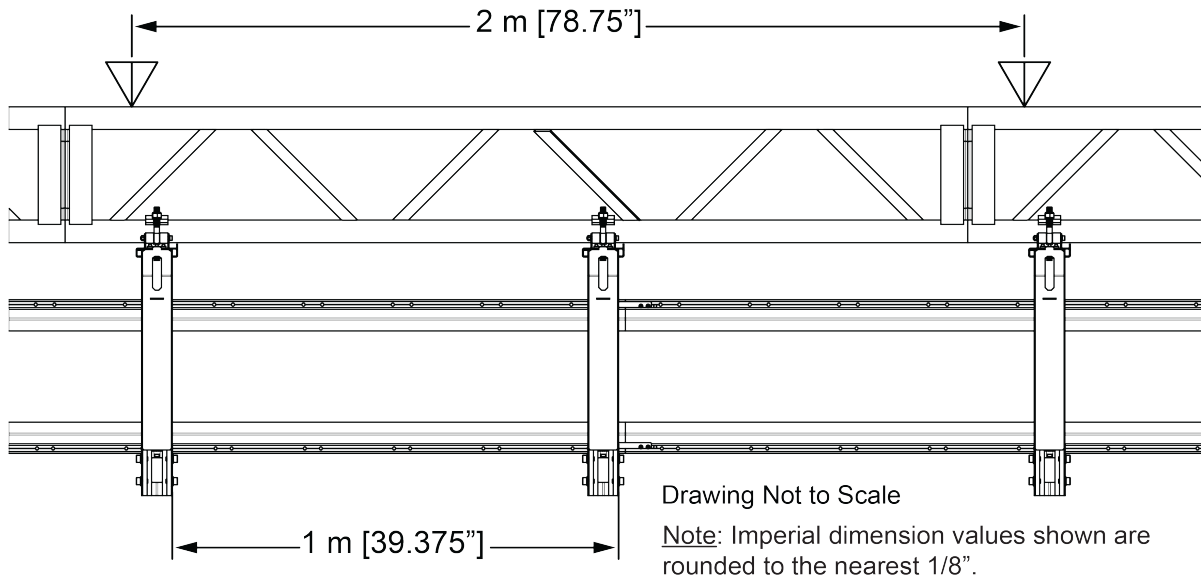
## Anchor Point Spacing and Loads

This section specifies the maximum distance between anchor points, and describes system loads.

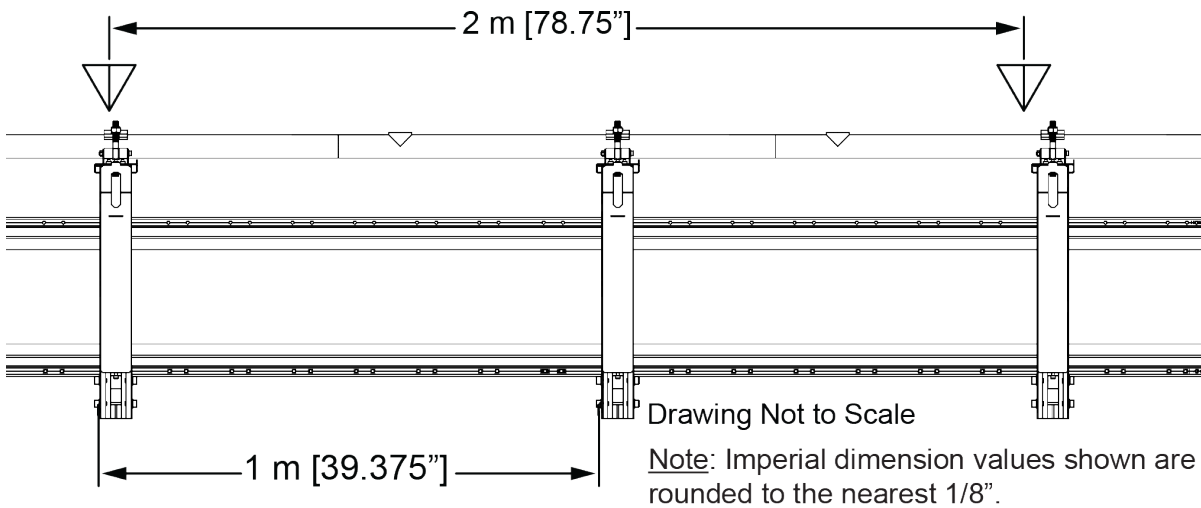
### Anchor Point Spacing

The anchor points for the track system must be spaced at intervals of 2.0 m (78.7") or less (see [Figure 25](#) with box truss configuration and [Figure 26](#) with ladder truss configuration).

**Figure 25 - Maximum Anchor Point Spacing - Box Truss**



**Figure 26 - Maximum Anchor Point Spacing - Ladder Truss**





## Loads

Total mass/loads (Dead and Live loads) for the system must be considered.

**IMPORTANT:** The mass/loads presented in this section do not include any safety factor. Safety factors should be applied based on local building and seismic codes.

Total mass/loads (Dead and Live loads) for the system consists of the following items:

- Dead load includes the Aluminum SkyDolly Truss, Aluminum Rails, Rail Support Frames, and Truss Clamps. The dead load for these items for each truss total:
  - › 51.4 kg/m (34.5 lbs/ft) for the box truss.
  - › 46.2 kg/m (31.04 lbs/ft) for the ladder truss.
- Live load includes the Dolly, Column/Lift, Head, and Payload ([Table 8](#)).

**Table 8 - Total Live Load for each Product Package**

| Product Package       | Column Type  | Pan/Tilt Head | Maximum Payload | Total Live Load (without safety tethers) |
|-----------------------|--------------|---------------|-----------------|--|
| FRO-SKY-X350-DLY      | 7" Fixed     | X350          | 6.8 kg (15 lbs) | 70.9 kg (156.3 lbs)                      |
|                       | 12" Fixed    | X350          | 6.8 kg (15 lbs) | 72.5 kg (159.8 lbs)                      |
|                       | 30" Fixed    | X350          | 6.8 kg (15 lbs) | 76.9 kg (169.6 lbs)                      |
|                       | 48" Fixed    | X350          | 6.8 kg (15 lbs) | 81.6 kg (179.9 lbs)                      |
| FRO-SKY-VR600-DLY     | 7" Fixed     | VR600         | 30 kg (66 lbs)  | 108.6 kg (239.4 lbs)                     |
|                       | 12" Fixed    | VR600         | 30 kg (66 lbs)  | 110.2 kg (242.9 lbs)                     |
|                       | 30" Fixed    | VR600         | 30 kg (66 lbs)  | 114.6 kg (252.6 lbs)                     |
|                       | 48" Fixed    | VR600         | 30 kg (66 lbs)  | 119.3 kg (263.0 lbs)                     |
| FRO-SKY-VR100-DLY     | 7" Fixed     | VR100         | 20 kg (44 lbs)  | 92.1 kg (203.0 lbs)                      |
|                       | 12" Fixed    | VR100         | 20 kg (44 lbs)  | 93.7 kg (206.6 lbs)                      |
|                       | 30" Fixed    | VR100         | 20 kg (44 lbs)  | 98.1 kg (216.3 lbs)                      |
|                       | 48" Fixed    | VR100         | 20 kg (44 lbs)  | 102.8 kg (226.6 lbs)                     |
| FRO-SKY-X350-FULL-S2  | S2 two-stage | X350          | 6.8 kg (15 lbs) | 124.5 kg (274.5 lbs)                     |
| FRO-SKY-VR600-FULL-S2 | S2 two-stage | VR600         | 30 kg (66 lbs)  | 162.2 kg (357.7 lbs)                     |
| FRO-SKY-VR100-FULL-S2 | S2 two-stage | VR100         | 20 kg (44 lbs)  | 145.7 kg (321.2 lbs)                     |

**Note:** Live load does not include cables, cable trolleys, or tow cables because their weight is dispersed along the track and is always considerably less per linear meter (or foot) than the SkyDolly unit (dolly, fixed column, head, and payload).

[Table 9](#) lists the Total Mass/Load for each Product Package option at each anchor point if spaced at 2 m (78.8") with a box truss configuration, and [Table 10](#) lists the same values with a ladder truss configuration.

**Table 9 - Total Mass/Load at each Anchor Point (based on maximum spacing of 2 m (78.8”) - Box Truss**

| Product Package       | Column Type  | Pan/Tilt Head | Maximum Payload | Total Mass/Load      |
|-----------------------|--------------|---------------|-----------------|----------------------|
| FRO-SKY-X350-DLY      | 7” Fixed     | X350          | 6.8 kg (15 lbs) | 173.7 kg (382.9 lbs) |
|                       | 12” Fixed    | X350          | 6.8 kg (15 lbs) | 175.3 kg (386.4 lbs) |
|                       | 30” Fixed    | X350          | 6.8 kg (15 lbs) | 179.7 kg (396.2 lbs) |
|                       | 48” Fixed    | X350          | 6.8 kg (15 lbs) | 183.5 kg (404.6 lbs) |
| FRO-SKY-VR600-DLY     | 7” Fixed     | VR600         | 30 kg (66 lbs)  | 211.4 kg (466.1 lbs) |
|                       | 12” Fixed    | VR600         | 30 kg (66 lbs)  | 213.0 kg (469.6 lbs) |
|                       | 30” Fixed    | VR600         | 30 kg (66 lbs)  | 217.4 kg (479.3 lbs) |
|                       | 48” Fixed    | VR600         | 30 kg (66 lbs)  | 222.1 kg (489.6 lbs) |
| FRO-SKY-VR100-DLY     | 7” Fixed     | VR100         | 20 kg (44 lbs)  | 194.9 kg (429.7 lbs) |
|                       | 12” Fixed    | VR100         | 20 kg (44 lbs)  | 196.5 kg (433.2 lbs) |
|                       | 30” Fixed    | VR100         | 20 kg (44 lbs)  | 200.9 kg (442.9 lbs) |
|                       | 48” Fixed    | VR100         | 20 kg (44 lbs)  | 204.7 kg (451.3 lbs) |
| FRO-SKY-X350-FULL-S2  | S2 two-stage | X350          | 6.8 kg (15 lbs) | 227.2 kg (500.9 lbs) |
| FRO-SKY-VR600-FULL-S2 | S2 two-stage | VR600         | 30 kg (66 lbs)  | 265.0 kg (584.2 lbs) |
| FRO-SKY-VR100-FULL-S2 | S2 two-stage | VR100         | 20 kg (44 lbs)  | 248.4 kg (547.6 lbs) |

**NOTE:** The total mass/load at each anchor point is calculated by adding 2 m worth of dead load, plus one Furio SkyDolly camera system including dolly, column, head, and maximum payload. It does not include cables, cable trolleys, or tow cables. The calculation assumes dollies will always be more than 1 m apart from each other (collision avoidance safety factor).



**Table 10 - Total Mass/Load at each Anchor Point (based on maximum spacing of 2 m (78.8") - Ladder Truss**

| Product Package       | Column Type  | Pan/Tilt Head | Maximum Payload | Total Mass/Load      |
|-----------------------|--------------|---------------|-----------------|----------------------|
| FRO-SKY-X350-DLY      | 7" Fixed     | X350          | 6.8 kg (15 lbs) | 168.5 kg (371.6 lbs) |
|                       | 12" Fixed    | X350          | 6.8 kg (15 lbs) | 170.1 kg (375.1 lbs) |
|                       | 30" Fixed    | X350          | 6.8 kg (15 lbs) | 174.5 kg (384.9 lbs) |
|                       | 48" Fixed    | X350          | 6.8 kg (15 lbs) | 179.2 kg (395.1 lbs) |
| FRO-SKY-VR600-DLY     | 7" Fixed     | VR600         | 30 kg (66 lbs)  | 206.2 kg (460.9 lbs) |
|                       | 12" Fixed    | VR600         | 30 kg (66 lbs)  | 207.8 kg (464.3 lbs) |
|                       | 30" Fixed    | VR600         | 30 kg (66 lbs)  | 212.2 kg (474.1 lbs) |
|                       | 48" Fixed    | VR600         | 30 kg (66 lbs)  | 216.9 kg (484.4 lbs) |
| FRO-SKY-VR100-DLY     | 7" Fixed     | VR100         | 20 kg (44 lbs)  | 189.7 kg (418.4 lbs) |
|                       | 12" Fixed    | VR100         | 20 kg (44 lbs)  | 191.3 kg (421.9 lbs) |
|                       | 30" Fixed    | VR100         | 20 kg (44 lbs)  | 195.7 kg (431.6 lbs) |
|                       | 48" Fixed    | VR100         | 20 kg (44 lbs)  | 199.5 kg (440.0 lbs) |
| FRO-SKY-X350-FULL-S2  | S2 two-stage | X350          | 6.8 kg (15 lbs) | 222.0 kg (489.5 lbs) |
| FRO-SKY-VR600-FULL-S2 | S2 two-stage | VR600         | 30 kg (66 lbs)  | 259.8 kg (572.8 lbs) |
| FRO-SKY-VR100-FULL-S2 | S2 two-stage | VR100         | 20 kg (44 lbs)  | 243.2 kg (536.2 lbs) |



## Maximum Force Due to Robot Movement

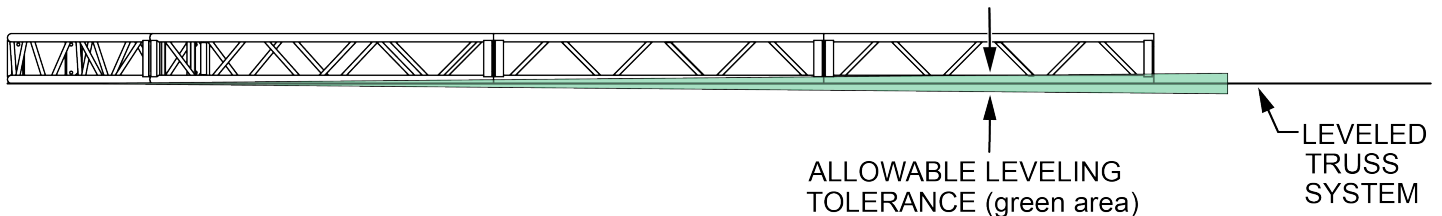
The maximum force on the infrastructure resulting from the movement of the dolly, including acceleration and deceleration, centripetal forces, and reaction forces when colliding with the end-stop bumpers is less than 9140 N.

## SkyDolly Truss Mounting Requirements

The SkyDolly truss system must be rigidly mounted to the building infrastructure to the following specifications:

1. For non-virtual systems, there are two options for each truss type:
  - i. **SkyDolly box truss** allowable leveling tolerance must be within 0.2 degrees. This is equivalent to a pitch of 3.5 mm over a 1 m distance, or 0.126" over a 3-foot distance (see [Figure 27](#)).

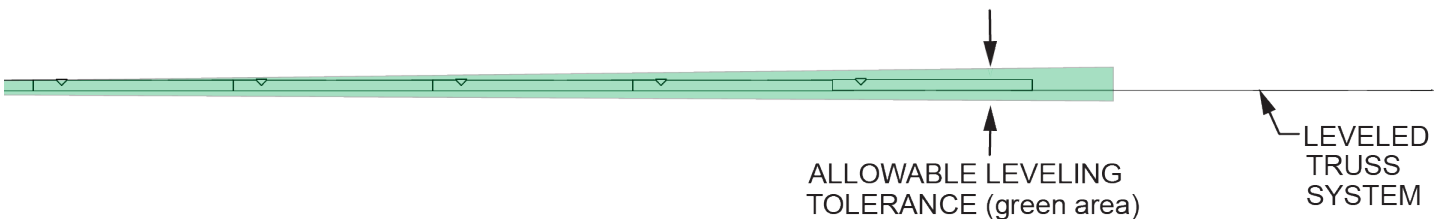
**Figure 27** - Allowable Level Tolerance for SkyDolly Box Truss (side view)



For virtual systems, the leveling may need to be tighter, depending on the studio dimensions, layout, and composition of shots.

- ii. The SkyDolly truss allowable leveling tolerance must be within 0.2 degrees. This is equivalent to a pitch of 3.5 mm over a 1 m distance, or 0.126" over a 3-foot distance (see [Figure 28](#)).

**Figure 28** - Allowable Level Tolerance for SkyDolly Box Truss (side view)



For virtual systems, the leveling may need to be tighter, depending on the studio dimensions, layout, and composition of shots.

2. All sections of the SkyDolly truss must be carefully aligned as they are joined, to ensure that
  - a. the bottom of the truss sections form a flat plane laterally. All portions of the truss must be within +/- 5 mm of this flat plane. Rail support frames that later attach to the truss and hold the rails have a +/- 5 mm vertical adjustment mechanism.
  - b. no portion of the truss is more than 6 mm from its intended lateral position. Rail support frames that later attach to the truss and hold the rails have a +/- 6 mm lateral adjustment mechanism.

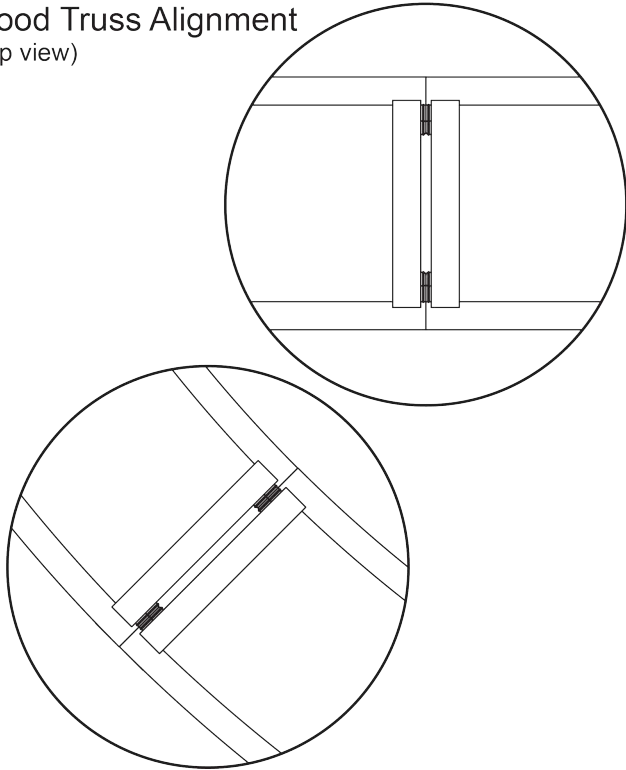
Wherever two truss sections are joined, there is a small amount of free play between bolts and bolt holes. This free play can result in slight misalignment of truss sections. It is important to ensure that each pair of truss sections are well-aligned so that as you join additional sections, cumulative free play remains within the tolerances specified above. For adjacent straight sections, ensure the pipes of the two truss sections are in line

with each other. For adjacent curved sections, ensure that the curve continues smoothly from one section to the other

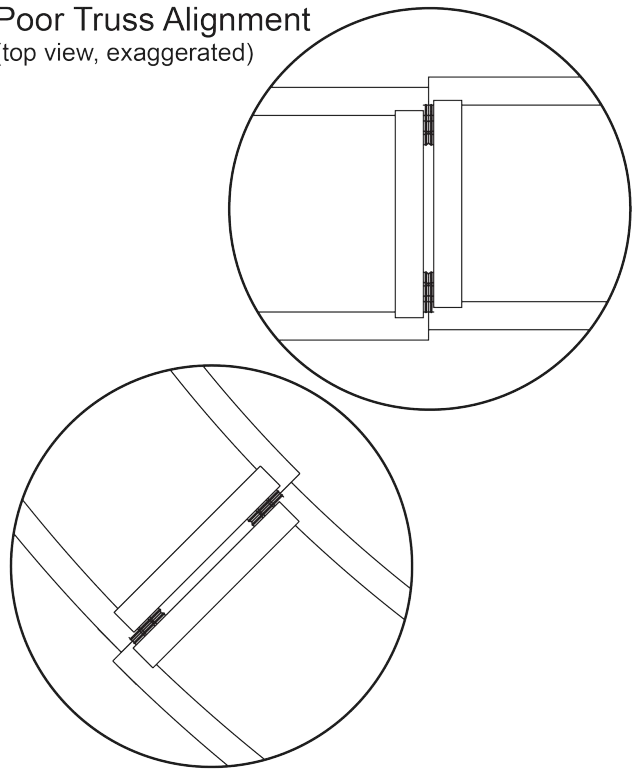
[Figure 29](#) illustrates the difference between good and poor truss alignment.

**Figure 29** - Good Truss Alignment (left), and Poor Truss Alignment (right)

Good Truss Alignment  
(top view)

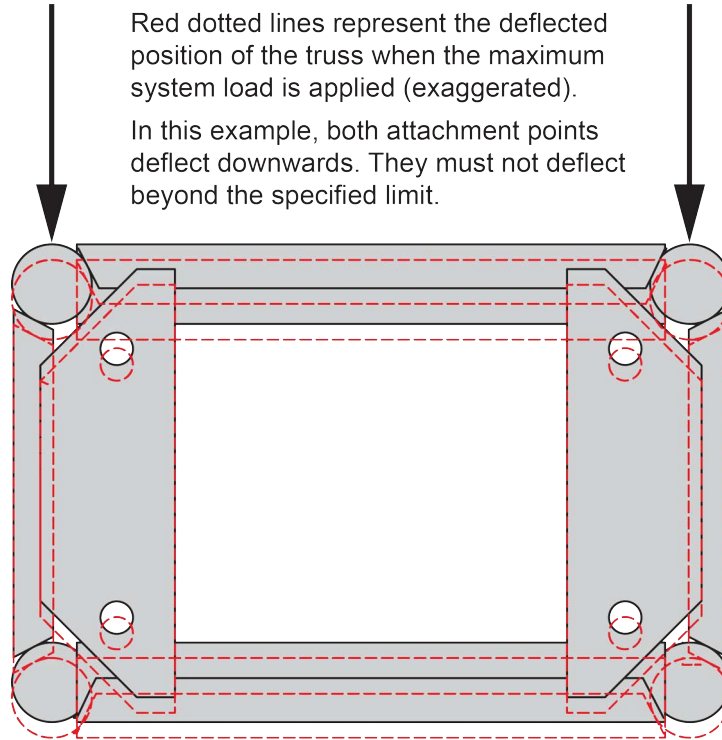


Poor Truss Alignment  
(top view, exaggerated)

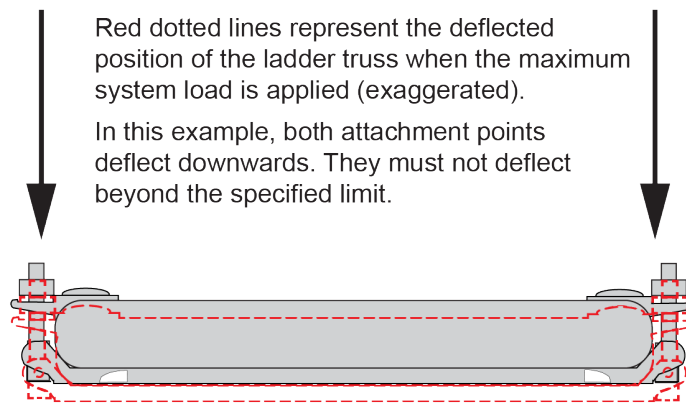


- c. SkyDolly truss tube attachment points must not deflect more than 0.5 mm (0.020") vertically under the maximum system load of 530 kg (1169 lb). Refer to [Figure 30](#) for Box Truss and [Figure 31](#) for Ladder Truss.

**Figure 30 - Allowable Truss Tube Attachment Deflection on a Box Truss**

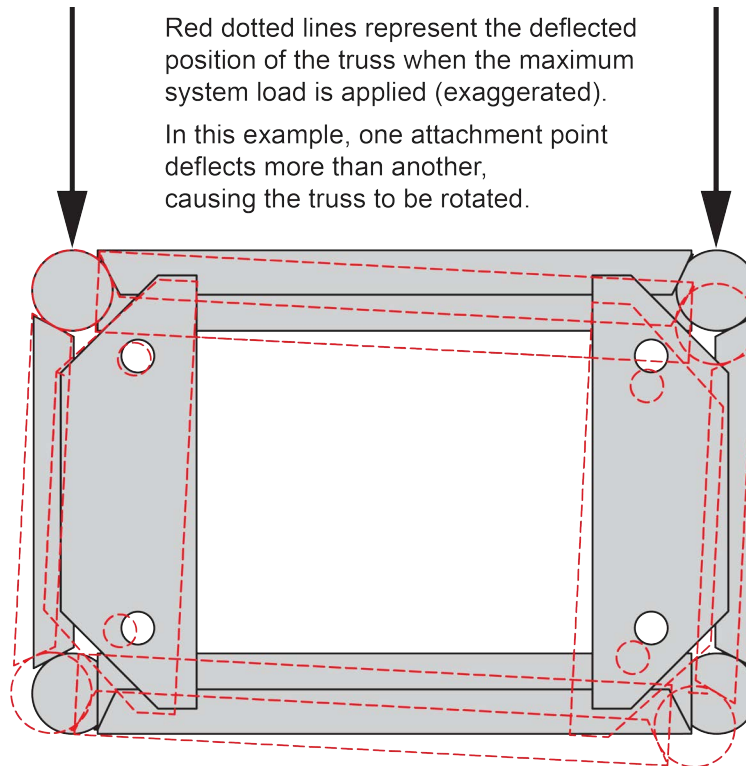


**Figure 31 - Allowable Truss Tube Attachment Deflection on a Ladder Truss**

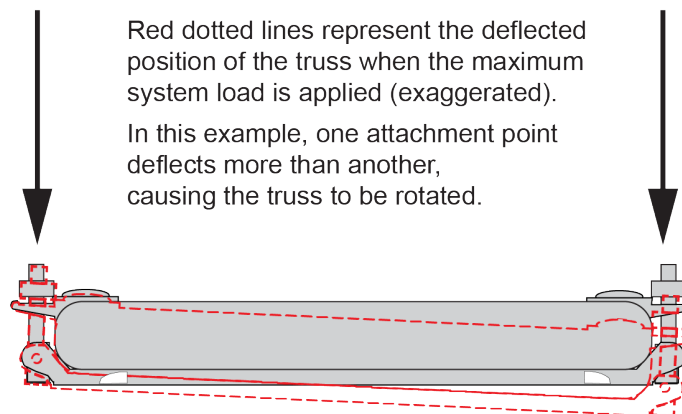


- d. SkyDolly truss tube attachment points must not deflect more than 0.5 mm (0.020") horizontally when subjected to a lateral force of up to 5000 N.
- e. Attachment points to the building infrastructure must not allow the difference in vertical deflection between the inner and outer SkyDolly truss tubes to exceed 0.1 mm (0.004") under the maximum system load of 530 kg (1169 lb). See [Figure 32](#) for Box Truss and [Figure 33](#) for Ladder Truss.

**Figure 32** - Allowable Difference in Truss Tube Attachment Deflection Between Tubes for Box Truss



**Figure 33** - Allowable Difference in Truss Tube Attachment Deflection Between Tubes for Ladder Truss



- f. Cantilever beams are acceptable if they satisfy all criteria in this section.

## SkyDolly Truss Mounting Hardware

Ross Video provides a custom-designed SkyDolly truss system capable of supporting the dolly rails, safety rails, rail support frames, dollies, and cable management. It is the customer's responsibility to install the SkyDolly truss system to the building infrastructure according to specifications in this document.

This responsibility includes providing and installing whatever hardware is needed to connect the SkyDolly truss to the attachment points in a rigid and secure manner, such that the system does not sway or deflect by more than 0.5 mm (0.020") in any direction under the maximum forces produced by the system.

This section describes requirements regarding hardware used to install the SkyDolly truss. It also provides examples of suitable hardware types.

**IMPORTANT:** Selection and installation of girder clamps, threaded rods, I-beams, or any other hardware or fasteners between the SkyDolly truss and the building structure is the responsibility of the installer, not Ross Video.

**IMPORTANT:** It is the installer's responsibility to ensure that any hardware or fasteners installed between the SkyDolly truss and the building structure is safe and appropriate, and that it is installed to manufacturer's specifications. Ross Video accepts no responsibility whatsoever for any damage, injury, or loss of revenue resulting from improper installation of the SkyDolly truss system.

### Hardware that attaches to the SkyDolly truss must:

- Form a rigid, immobile connection to the pipe, and keep the truss immobile. After installation, the hardware must not slide along the pipe or rotate around it. Slings and chains are not acceptable.  
For requirements related to required torsional rigidity, see "**SkyDolly Truss Mounting Requirements**" on [page 41](#).
- Not be secured by fasteners that can become loose, or that are designed for temporary installations. For example, hangers or clamps that are secured by wing nuts are not acceptable.
- Offer ample support to the underside of the pipe, preferably conforming to its shape. For example, band-style hangers with significant surface area are preferred.
- Not require any modification of the pipe, such as drilling holes.
- Meet all applicable safety regulations for the installation location.

[Figure 34](#) shows two styles of pipe hangers that may be suitable for securing the SkyDolly truss. The installer is responsible for ensuring the suitability and safety of any specific hangers to be used.

**Figure 34** - Examples of Potentially Suitable Pipe Hangers Manufactured by Eaton (left) and Arlington Industries (right)

