

Start Here!

1

Prepare for the Installation

1a Decide where to install the track and the operator position:

- The operator requires a view of the entire track area, or a video monitor view of it.
- A cable bundle up to 50m (164') long (maximum) connects to the side of the robotic dolly, and runs along the floor from the robot to the operator position. The robot cannot move beyond the reach of the cable bundle. Space is required alongside the track to allow free movement of the cable bundle. The cable bundle must never hang down over the edge of any riser or stage.
- The track must be installed on a solid, flat, level, clean surface that supports it along its entire length. For best performance the track must be screwed down.
- The robot and control components must be protected from rain or other moisture. Acceptable air temperature range is 5°C to 40°C (41°F to 104°F).

1b The cable bundle must contain an AC power supply cable (not included):

- The cable must be very light and flexible (stranded conductors only).
- The dolly end of the cable must terminate in a properly-grounded C13 female socket connector (IEC/EN 60320-1), which plugs into a C14 male plug connector on the dolly's integrated **power bar**.
- The Furio Live Dolly can accept either 100-126VAC at 60Hz, or 207-253VAC at 50Hz. The power supply circuit must be protected by a 15A fuse or circuit breaker (for 120VAC circuits), or an 8A fuse or circuit breaker (for 240VAC circuits). Do not overload the AC power supply circuit.
- Total power consumption of the Furio Live system is 1300 Watts (with lift) or 700 Watts (without lift). These values are for the robot and its control components only, and do not include power for cameras and accessories plugged into the dolly's integrated **power bar**.

The system is protected by a **T12.5A H 250V** fuse on the dolly **connection panel**. **IMPORTANT:** Any equipment you plug into the dolly's integrated power bar must accept the same voltage and frequency as is supplied to the dolly.

1c Provide AC power supply sockets at the operator position for the operator's video monitor(s) and any other operator equipment.

Note: Drawings are not to scale

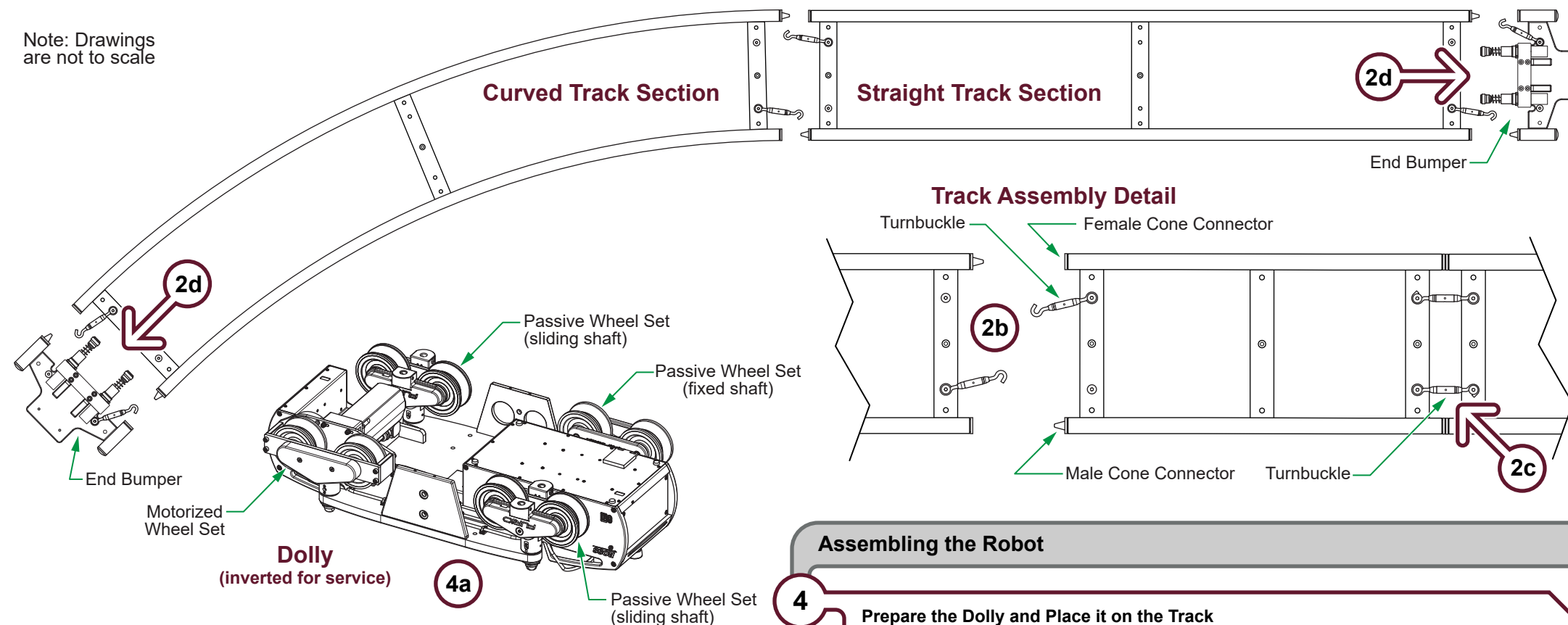

Installing the Track

2

Lay Out the Track

2a Unpack the track sections and end bumpers, and lay them out where you plan to install them.

IMPORTANT: Handle track sections and end bumpers carefully. Do not bend, drop, dent, or scratch them. Never step on the track or kick it.

2b Slide the track sections together, aligning the male and female cone connectors.

2c Using the attached turnbuckles, lock the track sections together.

IMPORTANT: Do not overtighten the turnbuckles!

2d Install an end bumper on each end of the track, using the attached turnbuckles to fasten the end bumpers to the track.

IMPORTANT: Do not overtighten the turnbuckles!

2e Use a damp cloth to clean the tops of the rails, to remove dust and debris.

3

Level and Secure the Track

IMPORTANT: The track **MUST** be properly leveled and fully supported along its entire length. For best performance, the track must be screwed down to the floor. If you are unsure about how to level and secure the track properly, consult an experienced grip.

Passive Wheel Sets

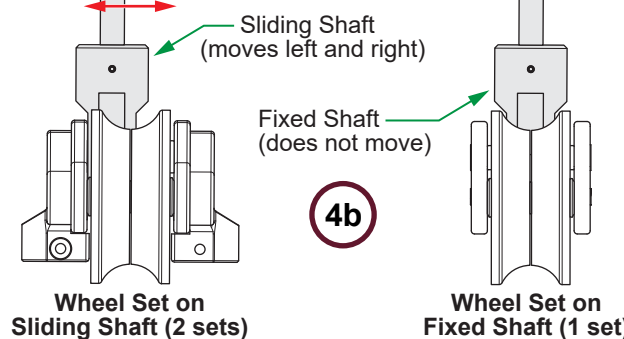

Dolly on the Track (top view)

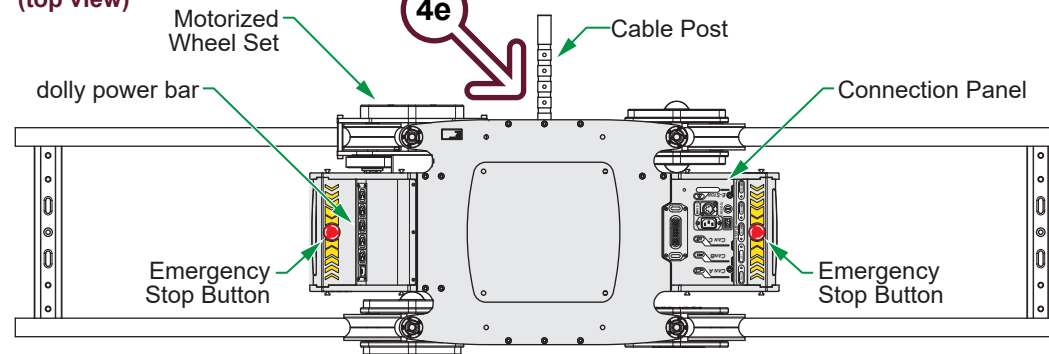

Assembling the Robot

4

Prepare the Dolly and Place it on the Track

CAUTION: The dolly is heavy. Get help when handling heavy items.

4a Unpack the dolly and place it upside-down on a table, with the wheels pointing up.

IMPORTANT: Never place dolly wheels on any surface other than a Furio track or specially-designed guide. Placing wheels on a flat surface damages them.

4b Inspect and service the dolly wheels:

- Turn the wheels to check that they move freely.
- **Tip: Motorized wheels** turn less freely than **passive wheels**. One corner of the dolly has motorized wheels; the other three corners have passive wheels.
- Clean the wheels using a dry foam brush to remove any debris from the soft wheel material, and then wipe them with a water-dampened cloth to remove any remaining dirt, dust, or grime.
- Two of the **passive wheel sets** are on **sliding shafts** that enable the wheel sets to move laterally. If required, apply light machine oil to lubricate the shafts.

IMPORTANT: Be sure to wipe up any excess oil immediately! Do not allow any oil to contact the soft wheel material or the track!

4c Decide how to orient the dolly on the track. If the track includes a curve, the motorized wheels typically sit on the outside rail to improve traction as the robot goes around the curve.

4d At the end of the track that is farthest from the operator position, place the dolly on the track. Ensure that all four wheel sets are properly seated on the track.

4e On the side of the dolly where the cable bundle will run, attach the cable post to the dolly, screwing it into a threaded hole as shown.

4f Twist both of the emergency stop buttons clockwise to disengage them.

4g Run the 50m (164') lens control cable (901-205-50) alongside the track, from the operator position to the robot at the far end of the track, to confirm that the cable can reach the robot anywhere along the track:

- If the robot has no lift, run the cable to a position 30cm (12") beyond the cable post on the dolly.
 - If the robot has a lift, run the cable to a position 2.5m (8') beyond the cable post on the dolly.
- Adjust the track length and/or operator position as required to ensure that cables will never be pulled tight.

IMPORTANT: The maximum operable length of Furio Live data cables is 50m (164'). Do not extend the length of these cables! Longer cables may fail!

Assembling the Robot (continued)

5

Attach Safety Wheels (four total)

Attach two **safety wheels** to each of the two **passive wheel units** that accept them. The wheel units that accept safety wheels are on opposite corners of the dolly.

To attach a safety wheel:

- Remove the **locking pin** by pressing and holding the **pin lock button** while sliding the **locking pin** out.
- Rotate the safety wheel **shaft** so the **notch** on the **shaft** faces the **rail**.
- Insert the **shaft** of the **safety wheel** into its hole, then press and hold the **pin lock button** while sliding the **locking pin** into its hole.

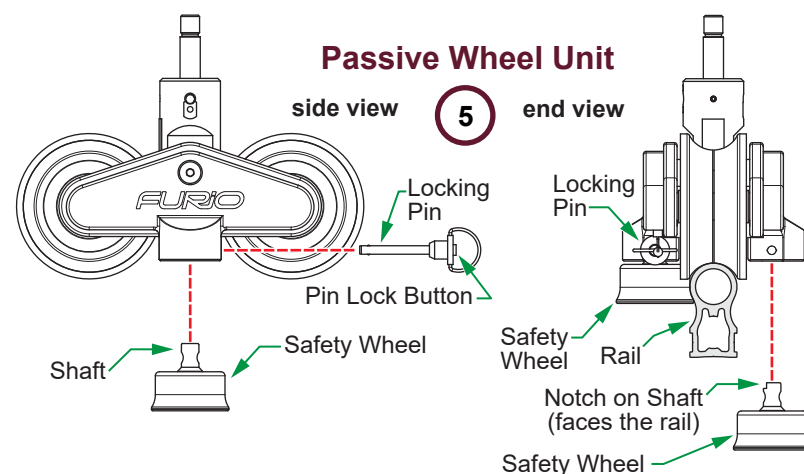

6

Attach the Robotic Lift and the Robotic Head

This step applies only if your system includes a robotic lift.

CAUTION: The lift and head are heavy. Get help when handling heavy items.

- Unpack the **lift**, lifting it by its **handles**, and gently lower it into the **recessed area** of the **dolly** so that the **lift connector** faces the end of the **dolly** that has the **connection panel**.
- Use an **8 mm hexagonal key wrench (hex key)** to fasten the **lift** to the **dolly (4 bolts)**. Tighten all bolts fully, but do not over-tighten them!
- Push the **connector lock** down firmly to secure the connection between the **lift** and the **dolly**.
- Unpack the **head**, and align it with the **round indent** on the **top of the lift**. An **alignment pin** (not shown) on the bottom of the head fits into an **alignment notch** on the mounting plate.
- Gently rotate the **camera cradle** out of the way, and then use a **hex key (8 mm)** to fasten the **head** to the **top of the lift (1 bolt)**. Do not over-tighten!

7

Attach the Mounting Plate and the Robotic Head

This step applies only if your system does not include a robotic lift.

CAUTION: The head is heavy. Get help when handling heavy items.

- Place the **mounting plate** into the **recessed area** of the **dolly**.
- Use an **8 mm hexagonal key wrench (hex key)** to fasten the **mounting plate** to the **dolly (4 bolts)**. Do not over-tighten the bolts!
- Unpack the **head**, and align it with the **round indent** on the top of the **mounting plate**. An **alignment pin** (not shown) on the bottom of the head fits into an **alignment notch** on the mounting plate.
- Gently rotate the **camera cradle** out of the way, and then use a **hex key (8 mm)** to fasten the **head** to the **mounting plate (1 bolt)**. Do not over-tighten!

8

Mount and Balance the Payload

8a Mount the payload (**max 12 kg (26.4 lbs)**) to the **camera cradle** loosely.

8b Balance the payload around the tilt axis of the **head** by adjusting the **camera cradle** and the payload position on the camera cradle as required, and then fasten the payload and camera cradle securely.

To test for balance, manually tilt the camera cradle 30° to 40° and then release it. Repeat this test a few times, tilting the head to various positions. If the payload is properly balanced, it will not move after you release it, regardless of its tilt position.

IMPORTANT: The payload must be balanced both horizontally and vertically, so that its center of mass is aligned with the tilt axis.

WARNING: Operating the robot with an imbalanced payload can damage the head. It can also impair smooth head movement, and increase the possibility of the robot derailing on curves.

Furio S2 Live Robot with Robotic Lift

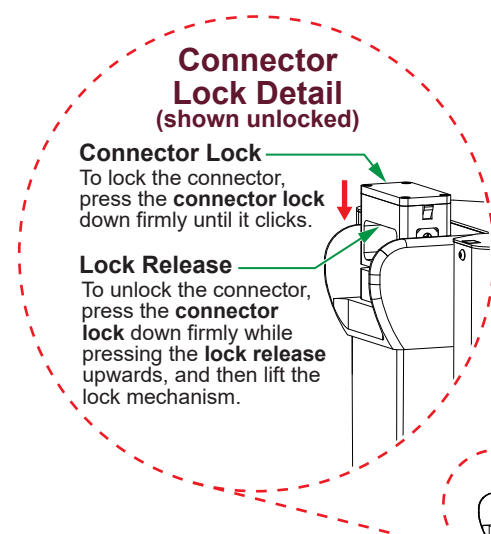

Manual Lift Switch

Passive Wheel Unit

side view **5** end view

6

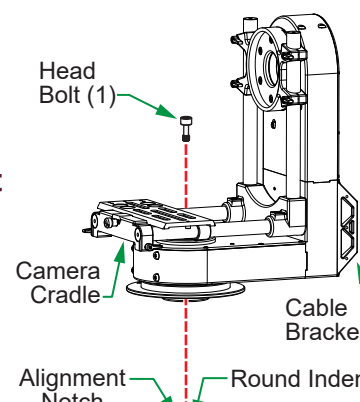

Furio S2 Live Robot without Robotic Lift

Dolly Connection Panel

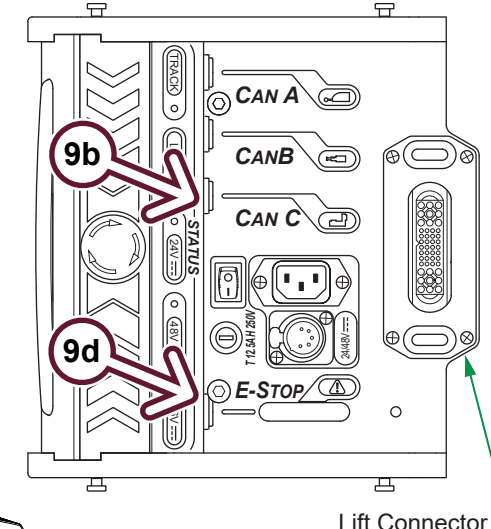

9

Cabling the Robot

Cable the Dolly and Head

- Connect a lens adapter cable between the lens control cable (**901-205-50**) and the camera and/or lens:
 - For Canon analog, use adapter cable **901-209-00**.
 - For Canon digital, use adapter cable **5100CR-746-01**.
 - For Fujinon (analog or digital), use adapter cable **5100CR-094-02**.
- Connect a **CAN data cable** from the **CAN C** connector on the **connection panel** to any **CAN** connector on the **head**. If the system has
 - no lift, use a **2.2m (7'2")** cable (**901-101-2.2M**).
 - a lift, use the **3m (10')** cable (**901-101-3M**).
- Connect the **short power cable** (attached to the dolly) from the **dolly power bar** to the **connection panel**.
- Connect the **50m (164')** **CAN data cable (901-101-50M)** to the **E-STOP** connector on the **connection panel**.
- Connect the **AC power supply cable** to the **male power input connector** on the **dolly power bar**.
- Connect all power, data, and video cables required to support the camera and other payload components.
- Starting at the **head**, use tie wraps to dress the cables:
 - Bundle the cables and secure them to the **cable bracket** on the **head**. Allow slack for tilt motion.
 - If the robot has a **lift**, wrap the cables in the **short cable sock**, starting at the **cable bracket**. Fasten the bundle to the **cable bracket** and to the **cable post** on the **dolly**. Allowing slack for pan, tilt, and lift motion, secure the cable bundle to a **handle** on the **lift**.
 - If the robot has no lift, secure the cables to the **cable post** on the **dolly**, allowing for pan and tilt motion. Handles on the dolly can be used for tying off cables.
 - Wrap the cables in the **long cable sock**, fasten the cable bundle to the **cable post** on the **dolly**, and run the bundle along the track to the operator position.
 - Ensure that the cables cannot touch the **wheel units**, that they do not obstruct the camera view, and that the cable bundle has space to move freely as the **dolly** rolls along the track. The cable bundle must never hang down over the edge of any riser or stage.

10

Next Step: Set Up the Control System

The control system for your robot is one of two types: PanBar or Joystick. For information about setting up your control system, refer to the appropriate instruction sheet:

- **Furio Live - Setting Up PanBar Control Equipment (5100DR-062-xx)**
- **Furio Live - Setting Up Joystick Control Equipment (5100DR-063-xx)**

Note: Drawings are not to scale