

ROSS

CamBot XY Pedestals

Technical Manual

Thank You for Choosing Ross

You've made a great choice. We expect you will be very happy with your purchase of Ross Technology.

Our mission is to:

1. Provide a Superior Customer Experience
 - offer the best product quality and support
2. Make Cool Practical Technology
 - develop great products that customers love

Ross has become well known for the Ross Video Code of Ethics. It guides our interactions and empowers our employees. I hope you enjoy reading it below.

If anything at all with your Ross experience does not live up to your expectations be sure to reach out to us at solutions@rossvideo.com.



David Ross
CEO, Ross Video
dross@rossvideo.com

Ross Video Code of Ethics

Any company is the sum total of the people that make things happen. At Ross, our employees are a special group. Our employees truly care about doing a great job and delivering a high quality customer experience every day. This code of ethics hangs on the wall of all Ross Video locations to guide our behavior:

1. We will always act in our customers' best interest.
2. We will do our best to understand our customers' requirements.
3. We will not ship crap.
4. We will be great to work with.
5. We will do something extra for our customers, as an apology, when something big goes wrong and it's our fault.
6. We will keep our promises.
7. We will treat the competition with respect.
8. We will cooperate with and help other friendly companies.
9. We will go above and beyond in times of crisis. *If there's no one to authorize the required action in times of company or customer crisis - do what you know in your heart is right. (You may rent helicopters if necessary.)*

Technical Manual for CamBot XY Pedestals

- Ross Part Number: 5100DR-042-03
- Publication Date: June 24, 2021. Printed in Canada.

Copyright

©2021 Ross Video Limited, Ross®, and any related marks are trademarks or registered trademarks of Ross Video Limited. All other trademarks are the property of their respective companies. PATENTS ISSUED and PENDING. All rights reserved. No part of this publication may be reproduced, stored in a retrieval system, or transmitted in any form or by any means, mechanical, photocopying, recording or otherwise, without the prior written permission of Ross Video. While every precaution has been taken in the preparation of this document, Ross Video assumes no responsibility for errors or omissions. Neither is any liability assumed for damages resulting from the use of the information contained herein.

Patents

Ross Video products are protected by patent numbers US 7,034,886; US 7,508,455; US 7,602,446; US 7,802,802 B2; US 7,834,886; US 7,914,332; US 8,307,284; US 8,407,374 B2; US 8,499,019 B2; US 8,519,949 B2; US 8,743,292 B2; GB 2,419,119 B; GB 2,447,380 B. Other patents pending.

Company Address and Contact Information



Ross Video Limited
8 John Street
Iroquois, Ontario
Canada, K0E 1K0

Ross Video Incorporated
P.O. Box 880
Ogdensburg, New York
USA 13669-0880

General Business Office: (+1) 613 • 652 • 4886

Fax: (+1) 613 • 652 • 4425

Toll Free Technical Support: 1-844-652-0645 (North America)
+800 1005 0100 (International)

Technical Support: (+1) 613 • 652 • 4886

E-mail for Technical Support: techsupport@rossvideo.com

ROSS VIDEO | HELP CENTER: <https://support.rossvideo.com/hc/en-us>

E-mail for General Information: solutions@rossvideo.com

Ross Video Website: <http://www.rossvideo.com>

Contents

Welcome	5
Text Formatting Conventions	5
Contacting Technical Support	6
Important Notices	6
Important Safety Notices	7
Product Overview	9
CamBot 600XY-S2 Pedestal	9
CamBot 600XY-S3 Pedestal	9
CamBot 700XY Pedestal	9
CamBot XY Pedestal Features	10
Site Requirements	13
Using CamBot XY Pedestals for Moving On Air Shots	13
Control Systems	15
SmartShell Control Application	15
The Joystick Panel	16
Local Control	17
Targeting a CamBot Pedestal	21
Maintenance	23
General Inspection and Cleaning	23
Installing a CamBot Target	24
Cleaning CamBot XY Pedestal Wheels	25
Replacing Pneumatic Struts	35
Technical Specifications	49
Specifications Table	49
Physical Dimensions	51

Welcome

This is the Technical Manual for the CamBot family of free-roaming XY Pedestal systems. CamBot XY pedestals feature the industry's best floor repeatability, fast and easy targeting, and straightforward design that provides years of reliable, low-maintenance operation.

This Technical Manual describes all available models of CamBot XY Pedestals, as well as CamBot robotic heads, Ross Robotics control systems, and CamBot system accessories.

Text Formatting Conventions

Special text formats are used in this Technical Manual to identify parts of the user interface, text that a user must enter, or a sequence of menus and sub-menus that must be followed to reach a particular command.

Text Format	Meaning
Bold text	Bold text is used to identify a user interface element such as a dialog box, menu item, or button. For example: In the Presets panel, tap Add .
Courier text	Courier text is used to identify text that a user must type. For example: In the address bar, type <code>localhost</code> and press Enter .
<i>Italic text</i>	Italic text is used to identify the titles of referenced guides, manuals, or documents. For example: For more information, refer to the <i>SmartShell Computer Quick Start Guide</i> .
>	Menu arrows are used in procedures to identify a sequence of menu items that you must follow. For example, if a step reads " Display > Widgets ," you would tap the Display menu and then tap Widgets .

Contacting Technical Support

At Ross Video, we take pride in the quality of our products, but if problems occur, help is as close as the nearest telephone.

Our 24-hour Hot Line service ensures you have access to technical expertise around the clock. After-sales service and technical support is provided directly by Ross Video personnel.

During business hours (Eastern time), technical support personnel are available by telephone any time. Emergency after hours calls are answered by an answering service (live person) who will patch your call to the on-call support specialist. In the event that the on-call person is assisting another customer, the answering service will contact the back-up support specialist.

Our team of highly trained staff is available to react to any problem and to do whatever is necessary to ensure customer satisfaction.

- **Toll Free Technical Support 24/7:** 1-844-652-0645 (North America), or +800 1005 0100 (International)
- **Technical Support:** (+1) 613-652-4886
- **E-mail for Technical Support:** techsupport@rossvideo.com
- **ROSS VIDEO | HELP CENTER:** <https://support.rossvideo.com/hc/en-us>
- **E-mail for General Information:** solutions@rossvideo.com
- **Ross Video Website:** <http://www.rossvideo.com>

Important Notices

This section contains important notices.

Korean Class A Notice

The following is the Korean Class A Broadcasting and Telecommunication Products for Business Purpose Statement.









이 기기는 업무용(A급) 전자파적합기기로서 판매자 또는 사용자는 이 점을 주의하시기 바라며, 가정외의 지역에서 사용하는 것을 목적으로 합니다.







The preceding statement applies to the following Ross Video components, and may also apply to others:

- **5100AR-252-01** — 6-Axis Unified Robotics Control Panel
- **5100AR-825-01** — CamBot AGNOSTIC S3 Pedestal
- **5100AR-826-01** — CamBot 600XY S2 Pedestal

Important Safety Notices

The following table contains important safety notices and safety instructions. Before using this product and any associated equipment, read and keep these notices and instructions. Heed all warnings and follow all safety instructions.

	Caution	This equipment must be operated by trained personnel only. This equipment must be operated in a controlled and restricted environment only.
	Warning	The safe operation of this product requires that a protective earth connection be provided. A grounding conductor in the equipment's supply cord provides this protective earth. To reduce the risk of electrical shock to the operator and service personnel, this ground conductor must be connected to an earthed ground. Use only power cords specified for this product and certified for the country of use. Do not defeat safety purpose of the grounding-type plug. A grounding type plug has two blades and a third grounding prong. The third prong is provided for your safety. If the provided plug does not fit in to your outlet, consult an electrician for replacement of the obsolete outlet. Protect power cord from being walked on or pinched, particularly at plugs, convenience receptacles, and points where they exit from the apparatus.
	ESD	ESD Susceptibility — This symbol on the equipment or within the equipment manual indicates that an electrical or electronic device or assembly is susceptible to damage from an ESD event.
	Warning	Hazardous Voltages — This symbol on the equipment or within the equipment manual indicates the presence of uninsulated “dangerous voltage” within the product enclosure that may be of sufficient magnitude to constitute a risk of shock to persons.
	Warning	Indoor Use: “WARNING – TO REDUCE THE RISK OF FIRE OR ELECTRIC SHOCK, DO NOT EXPOSE THIS APPARATUS TO RAIN OR MOISTURE” Do not use this apparatus near water. Do not block any ventilation openings. Install in accordance with manufacturer's instructions. Do not install near heat sources such as radiators, heat registers, stoves, or other apparatus (including amplifiers) that produce heat. Only use attachments/accessories specified by the manufacturer. Unplug this apparatus during lightning storms or when unused for long periods of time. Clean only with a dry cloth.
	Warning	Refer all servicing to qualified personnel. Servicing is required when the apparatus has been damaged in any way, such as power-supply cord or plug damage, liquid has been spilled or objects have fallen into the apparatus, the apparatus has been exposed to rain or moisture, does not operate normally, or has been dropped.
	Warning	To reduce the risk of fire, replacement fuses must be the same type and rating.
	Warning	This product contains safety critical parts, which if incorrectly replaced may present a risk of fire or electrical shock. Components contained within the product's power supplies and power supply area are not customer-serviceable and should be returned to the factory for repair.
	Caution	Ensure that proper cable management techniques are used at all times. Bundle and wrap cables neatly, and provide adequate strain relief and slack where necessary. Test your cable installation by moving the robotic units through their entire range of motion and observing the cables, to ensure that they do not become taut, or snag on anything. Avoid running cables along floors in places where they may present a tripping hazard. Clearly mark areas where cables may present a tripping hazard, and keep personnel away from such areas. Inspect cables periodically for damage, and to ensure that proper cable management is maintained.

	Warning	Damaged or improper cables may cause electric shock and/or fire. Ensure that all cables and connectors are of suitable type for their purpose, and that all power cable conductors are of adequate gauge for the voltage and current required. Inspect all cables periodically to check for damage. If a cable becomes damaged, turn off power to the system immediately, and then replace the damaged cable.
	Warning	Serious injuries can result from people tripping over equipment, such as cables. Methods of reducing such risks include, but are not limited to, the following: <ul style="list-style-type: none"> • Erecting signs at studio entrances to remind people about tripping hazards and other studio hazards. • Training personnel about safety procedures and proper cable management techniques. • Showing personnel and guests the locations of cables equipment, and explaining that robotic cameras and cables attached to them may move at any time. • Escorting guests at all times while in the studio. • Ensuring adequate lighting when working in the studio. • Marking safe paths and/or restricted areas, to keep people away from moving robots and potential tripping hazards.
	Caution	Loose or overtightened bolts may cause equipment damage. When servicing, tighten bolts to specified torque.
	Warning	Moving parts may present a pinching hazard. Keep all personnel away from robots when they are operational. When a robotic head, pedestal, or robotic lift column moves, fingers touching or near the unit or the payload may become pinched. When installing or adjusting the payload, ensure that power to the system is turned off. When operating a robotic pedestal locally, touch only the pan bars and the local control unit (if equipped).
	Warning	When servicing or moving equipment, always observe safe handling practices. Get help to move heavy items. Use safe lifting techniques. Follow all safety rules of your workplace.
	Caution	Loose payloads may slip, causing equipment damage and injury. Periodically check all bolts that fasten the payload, to ensure that they are tightened to specified torque. If the payload is loose or slips, ensure that it is properly balanced and fastened before operating the robot.
	Warning	Imbalanced payloads may cause equipment damage and may present a tipping hazard. Ensure payloads are properly balanced. If you adjust a payload, always rebalance it.

Product Overview

The CamBot family of free-roaming XY pedestals offers three distinct choices to suit a wide variety of studio layouts and capital budgets: the mid-sized 600XY-S2 and 600XY-S3, and the original high capacity 700XY. All three family members are built on the same proven pedestal base, which features the industry's best floor repeatability, fast and easy targeting, and a straightforward design that provides years of reliable, low-maintenance operation.

CamBot 600XY-S2 Pedestal

With its breakthrough entry-level price-point, the new 600XY-S2 enables a whole new segment of robotics users to take advantage of the flexibility and versatility of free-roaming robotic pedestals.

600XY-S2 combines the S2 Lift with a 600-Series head. With a net payload of 125 lbs (57 kg), 600XY-S2 can handle most of today's studio camera configurations, including ENG/EFP-style cameras and lenses, with full-sized prompters, talent monitors, clocks and tally lights.

CamBot 600XY-S3 Pedestal

The mid-range 600XY-S3 combines the price benefits of the smaller payload 600-Series head with a 50% increase in elevation range (i.e. difference between min and max elevation) over 600XY-S2. By mounting the 600-Series head on the heavy-duty three-stage lift from the flagship 700XY, a wider range of shots is achieved, including the ability to naturally cover both standing and seated talent positions.

CamBot 700XY Pedestal

At the top of the range sits the market-leading 700XY, whose payload capacity, accuracy and reliability are unmatched. With a 200 lbs (90 kg) net payload, 700XY can support the largest box lens and studio camera combinations still in use today.

CamBot XY Pedestal Features

Figure 1 shows the CamBot 600XY-S2 Pedestal and the CamBot 700XY Pedestal.

CamBot XY Pedestals

(drawings are not to scale)

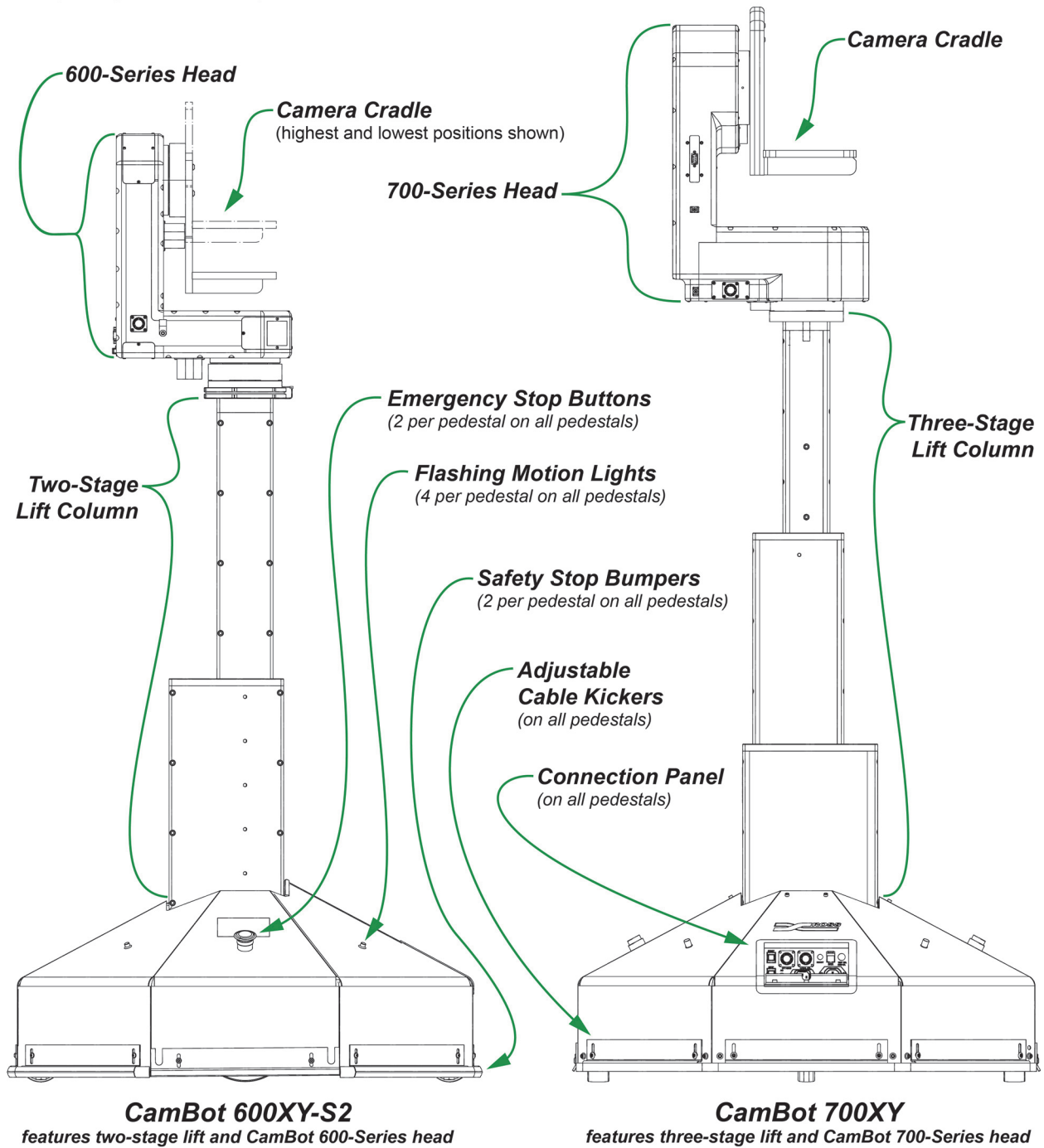

Figure 1 - CamBot XY Pedestals

Connection Panel

This section describes features of the connection panel, which is located at the base of each CamBot XY Pedestal.

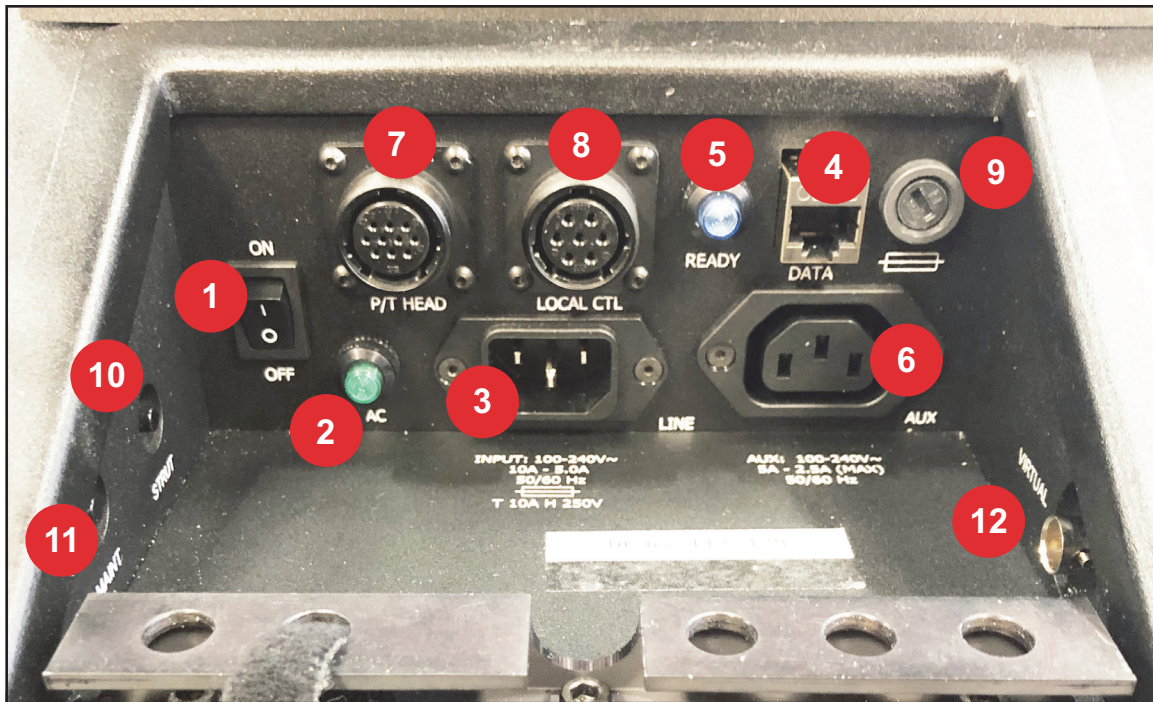

Figure 2 - CamBot XY Pedestal Control Panel

Table 1 describes the connectors and controls on the connection panel, as labeled in **Figure 2**.

Table 1 - CamBot XY Pedestal Control Panel Connectors and Controls

Label	Description
1	POWER ON / OFF Switch Turns power ON and OFF for the pedestal and subsystems.
2	AC Light Will illuminate when the pedestal has power turned ON .
3	LINE Connector AC power in, either 120VAC or 240VAC. The voltage for each pedestal is configured at the factory, based on the country of operation.
4	DATA Connector CAT5E connection for data from the computer.
5	READY Light Will illuminate when the pedestal is turned ON . Will blink when a data connection is established.
6	AUX Connector AC power out, for subsystems.
7	P/T HEAD Connector 10-pin connector for power and data for the pan and tilt head.

Label	Description
8	<p>LOCAL Connector Seven-pin connector for local control of the pedestal (optional).</p>
9	<p>FUSE Hatch The required fuse is type T 5A H 250V.</p>
10	<p>STRUT Button Used when installing/removing pneumatic struts. To raise the lift column to the highest position for strut removal and installation, turn the pedestal OFF. Press and hold the STRUT button and then turn the pedestal ON. The pedestal initializes, lowering and then raising the lift column. Continue to hold the STRUT button until the lift column starts to rise.</p>
11	<p>MAINT Button Technical Support personnel use this feature to configure a pedestal's IP address when the current IP address is unknown. After using the MAINT button, the technician uses telnet or ssh to login into the pedestal and change the IP address to the desired value.</p> <p>The exact behavior of the MAINT button depends on the version of software on the pedestal:</p> <ol style="list-style-type: none"> 1) CamBot firmware (all versions) — Temporarily resets the pedestal's IP address to the factory default value (192.168.0.126). To temporarily reset the pedestal's IP address to the factory default value, turn OFF the pedestal, press and hold the MAINT button, and then turn the pedestal ON. Continue holding the MAINT button for 30 seconds. The IP address is reset to 192.168.0.126. Note: If the MAINT button is used but you do not configure a new IP address, the pedestal reverts to its previous IP address on reboot. 2) Furio firmware (versions 5.2.100.x & 5.2.200.x only) — Permanently resets the pedestal's IP networking configuration to the factory default values (192.168.3.11, netmask 255.255.255.0, gateway 192.168.3.1). To permanently reset the pedestal's IP networking configuration to the factory default values, turn OFF the pedestal, press and hold the MAINT button, and then turn the pedestal ON. Continue holding the MAINT button for 30 seconds. The IP address is reset to 192.168.3.11, the netmask to 255.255.255.0, and the gateway to 192.168.3.1. Note: DashBoard Walkabout can also be used to discover and change networking settings. 3) Furio firmware (version 5.2.300.xxxx and later) — DashBoard Walkabout must be used to discover and change networking settings. The walkabout agent doesn't start by default. To start it, turn OFF the pedestal, press and hold the MAINT button, and then turn the pedestal ON. Continue holding the MAINT button for 30 seconds. The walkabout agent starts and will run for 12 hours. Use DashBoard Walkabout to discover and change the networking settings. Note: the factory-default network configuration is IP address 192.168.3.11, netmask 255.255.255.0, and gateway 192.168.3.1.
12	<p>BNC Connector Video sync input (for genlock).</p>

Site Requirements

The following documents provide information about site requirements for installing CamBot XY Pedestals and compatible control systems:

- ***CamBot Studio Site Requirements (5100DR-022-xx)***
Applies to all CamBot robot systems, including CamBot XY Pedestals.
- ***Control Room Site Requirements for Standard Control Station (5100DR-021-xx)***
Applies to Ross Robotics systems that use a Standard SmartShell Control Station (RRB-CTL-3 or RRB-CTL-6).
- ***Control Room Site Requirements for Standalone Control Station with Integrated Server (5100DR-032-xx)***
Applies to Ross Robotics systems that use a Standalone SmartShell Control Station with Integrated Server (RRB-CTL-3-SRV or RRB-CTL-6-SRV).

To obtain electronic copies of these documents, contact your Ross Video sales representative.

Using CamBot XY Pedestals for Moving On Air Shots

CamBot free-roaming XY pedestal systems are in widespread use around the world in demanding studio applications. In many of these applications, on air moving shots are desired as part of the production. This section clarifies what to expect when using CamBot XY pedestals for on air moves, and describes methods to ensure the best quality moving shots.

Under the right conditions, and with realistic expectations, CamBot XY pedestals can be used to produce good quality moving shots, including shots involving pedestal movement. However, not every type of shot can be attained in a given environment and trade-offs must sometimes be made to achieve smooth on air results.

Lens, Head, and Column Movements

Lens Movement - Zoom & Focus

CamBot robotic camera systems achieve extremely smooth lens movements, controlling a variety of Canon and Fujinon lenses. Note that older model lenses may show some "stepping" at very slow lens speeds due to the resolution of the circuitry in those old lenses. We recommend you consult with Ross Video before lens deployment, to ensure that your specific lens model can be optimally supported.

Head Movement - Pan & Tilt

Pan and tilt movements work very well on the air. For best performance it is important to have a properly installed, well balanced payload, and a rigid camera and prompter mounting system to avoid any shake from these systems making its way into the shot. Ross Video has worked with most teleprompter vendors to provide advice on how to ensure that their mounting systems work well with our robotics. We also recommend and sell CueScript equipment to help you achieve best results.

Column Moves - Up & Down

Vertical moves also work very well for on air shots.

Combination Lens + Head + Column

Lens, head, and column moves can be combined to produce great looking motion shots on the air. These types of shots generally work very well with a well-balanced and rigidly mounted camera and prompter system.

Pedestal (Floor) Movements

Smooth pedestal movements (dolly shots) are possible using CamBot XY pedestals under the right conditions. To achieve these optimal conditions there are a number of things to consider, each of which impacts the quality of the shot.

Technical Set Up

The following are key technical requirements that will ensure the best possible results when using CamBot XY pedestals for dolly shots:

- ***A smooth, clean studio floor***
A rough or dirty floor will cause vibration in the camera shots. For example, spike tape is thick enough to induce noticeable vibrations.
- ***Rigid camera, prompter, and accessory mounts***
A loosely-mounted or poorly designed rig will cause vibration and resonance that translates into the shot.
- ***Properly balanced payload***
A properly balanced payload is essential to achieving smooth on air shots for all types of moves, including pedestal movements. An improperly balanced payload can also cause accelerated wear and tear on the system.
- ***Optimized struts for the payload***
The correct strength of strut is required to offset the weight of the camera payload. Therefore, it is essential to determine as accurately as possible the total weight of the camera, prompter, accessory equipment, and counterweights before the system is delivered. Ross Video provides the appropriate struts for your payload.
- ***Optimized torsion springs for the payload***
Torsion springs in the pedestal base are factory installed, but can be changed during commissioning if necessary.
Torsion spring tension is selected based on the payload, to achieve better performance (less sway) on dolly shots. It should be noted, however, that increasing spring tension to improve smoothness may affect pedestal tracking accuracy.

Operating Considerations

The following are operational considerations to help achieve best results when using a CamBot XY pedestal for dolly shots:

- ***Slower shots work better than faster shots***
Slower shots mean slower and smoother acceleration and deceleration.
- ***Wide shots work better than zoom shots***
Zooming in accentuates image shake.
- ***Take the shot to air once the movement is underway***
Using the shot after movement has started, and cutting away from it before it has stopped will minimize any start/stop jerkiness or vibration from going on air.
- ***Recalled shots (presets) perform better than manual shots***
When performing recalled shots (presets), CamBot's sophisticated movement algorithms calculate the optimum acceleration profile for smooth motion.
- ***Cue presets prior to recalling them***
In the SmartShell control application, you can cue a preset before you recall it. Cuing a preset commands the CamBot XY pedestal to rotate its base so its wheels face the direction of movement. The farther in advance this is done, the less residual vibration there will be that could affect a shot once the move is executed.

Control Systems

CamBot XY Pedestal systems feature an open API that allows them to be controlled via a variety of technologies, including Ross Video's SmartShell control application and joystick panel, production switchers such as Ross Video Carbonite, and broadcast automation systems such as Ross Video OverDrive. They can also be manually controlled using the Local Control Box, which is an optional accessory that can be mounted on pan bars attached to the robot's payload.

This section contains the following topics about controlling CamBot XY Pedestals:

- "SmartShell Control Application" on page 3-15
- "The Joystick Panel" on page 3-16
- "Local Control" on page 3-17
- "Targeting a CamBot Pedestal" on page 3-21

SmartShell Control Application

The main interface for controlling Ross Video CamBot and Furio robots is SmartShell, an easy-to-use touch-screen interface that enables you to control camera systems automatically using stored presets, and manually using a joystick panel and/or buttons in the user interface.

The SmartShell computer comes with a touch screen monitor. You can also use the provided mouse and keyboard.

For detailed information about SmartShell, see the *SmartShell User Guide (5100DR-002-xx)*.



Figure 1 - The SmartShell Control Application (in Matrix View for Panel Mode), Controlling CamBot and Furio Robots

The Joystick Panel

You can control CamBot and Furio camera systems manually using the joystick panel (see **Figure 2**). The joystick panel enables you to move multiple axes of a camera system simultaneously, for smooth camera operation.

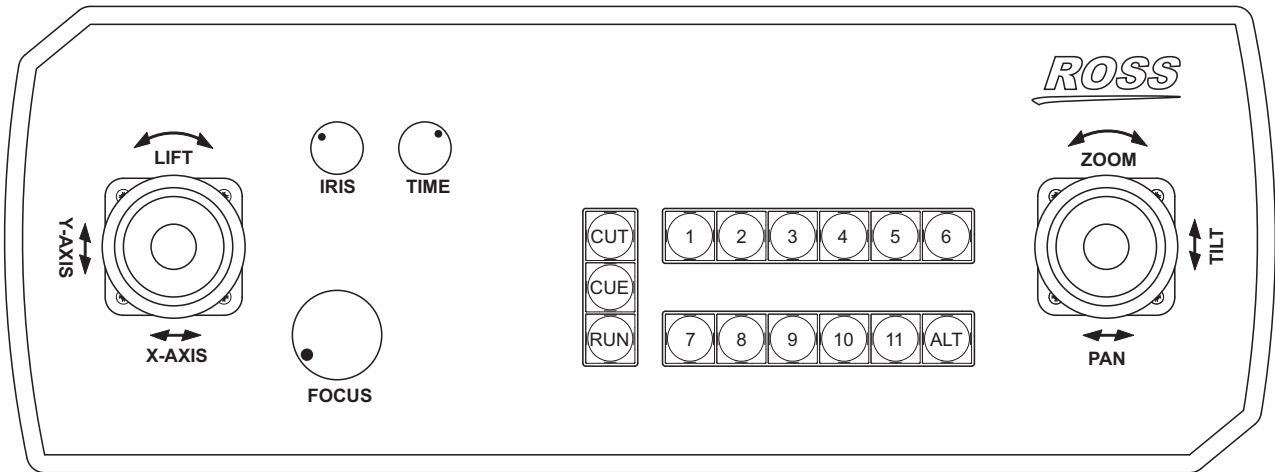

Figure 2 - Joystick Panel (may not appear exactly as shown)

During a show, operators typically use the joystick panel in conjunction with the matrix view in SmartShell. Alternatively, you can use the **Axis Control** panel in SmartShell to control camera systems manually. For more information, see the **SmartShell User Guide (5100DR-002-xx)**.

Joystick Panel Controls

This section describes how the joystick controls work. Joystick controls include:

- **Camera Selection buttons (1 - 11)** — Each button selects/deselects a camera to control. Only one camera can be selected at a time.
- **Left Joystick** — Controls left column height, floor movement for XY pedestals, and track motion for Furio dollies.
If you are controlling an XY pedestal, press and hold the left joystick while twisting it, to rotate the pedestal without affecting the pan position of the head.
In some Ross Robotics systems, the joystick panel does not include a left joystick. If your system does not include Furio track-mounted dollies, lift columns, or XY pedestals, your joystick panel may not include a left joystick.
- **Right Joystick** — Controls pan, tilt, and lens zoom. The right joystick button temporarily disables variable zoom (ZOOMVAR).
- **Joystick buttons** — If you are controlling a CamBot XY pedestal, press and hold both joystick buttons, and then push the joysticks forward and back to drive the pedestal. Control is similar to controlling a tracked vehicle.
- **IRIS knob** — Reserved for future use. Not supported in the current software version.
- **TIME knob** — Rotate to adjust the recall duration for presets before you run them. You can also use the **TIME** knob to specify duration when creating presets.
- **FOCUS knob** — Rotate to adjust the lens focus, or press the knob enter or exit Quick Focus mode.
- **CUT button** — Moves the selected camera system to the preset position as quickly as possible.
- **CUE button** — Prepares a move (Furio) or preset (CamBot XY pedestal) before you recall it.
- **RUN button** — Moves the camera system to the preset or move position in the specified time period, if possible.

- **ALT button** — Enables you to perform alternative functions, including the following:
 - › Enables the **TIME** knob to modify the duration of a running preset. To modify the duration, press and hold the **ALT** button, and then turn the **TIME** knob clockwise to increase the duration or counter-clockwise to decrease it. This applies to CamBot robots only.

In SmartShell, the matrix button for the preset shows the remaining duration. The progress bar shows the elapsed time and the new total duration.

Tip: When operating a CamBot, the **ALT** button is normally yellow. When you press the button, it turns green unless the camera is on-air, in which case it turns red. The red on-air indicator applies only if your system includes tally integration.

Local Control

The CamBot local control box is an optional accessory that enables you to manually control a CamBot XY pedestal system locally, using pan bars and the control box itself. When you use the local control box, all commands from other control systems are ignored. The local control box is used only on camera systems that include a robotic lift column and/or a robotic pedestal.

The local control box enables you to switch seamlessly between remote and local control without having to power down or re-target the pedestal. Position tracking data is uninterrupted when switching between remote and local control.

This section explains how to perform tasks using the local control box, including:

- “**Switching Between Remote Control and Local Control**” on page 3-18
- “**Moving the Pedestal Across the Studio Floor**” on page 3-19
- “**Raising and Lowering the Lift Column**” on page 3-19
- “**Panning and Tilting the Head**” on page 3-19
- “**Adjusting Drag for Pan and/or Tilt**” on page 3-20
- “**Locking and Unlocking Tilt and/or Pan**” on page 3-20
- “**Rotating the Pedestal**” on page 3-21

Figure 3 shows the local control box.

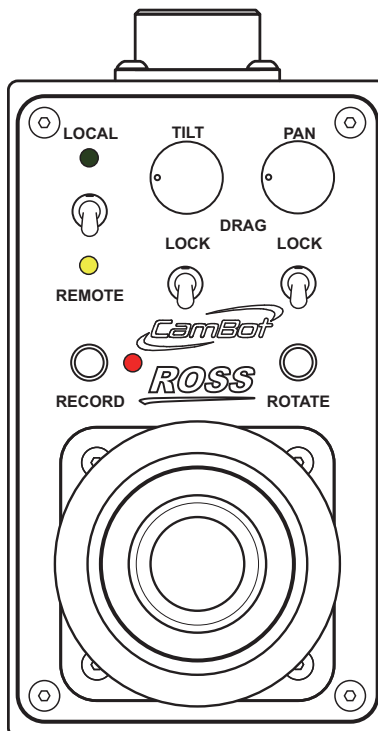

Figure 3 - The Local Control Box

Notes:

- The local control box does not control lens functions, such as zoom, focus, and iris. These features can be operated via controllers mounted to the pan bars (if equipped).
- The **RECORD** button is not operational. It is reserved for future use.

Switching Between Remote Control and Local Control

Switching to local control enables you to control the pedestal system locally, using pan bars and the local control box. Switching to remote control allows the SmartShell application or an automation system to take control of the camera system.

LEDs above and below the **LOCAL/REMOTE** switch indicate the current control status. Green indicates local control, and yellow indicates remote control. **Figure 4** shows the **LOCAL/REMOTE** switch.



Figure 4 - The LOCAL/REMOTE Switch

To Switch from Remote Control to Local Control

1. Ensure that the camera system is at rest, meaning that
 - it is not moving,
 - it is not running a preset,
 - no automation system is moving it, or is about to move it, and
 - no one is operating it manually using the joystick panel.
2. On the local control box, put the tilt and pan lock switches in the unlocked (downward) position. This step ensures that you will be able to move the head freely as soon as you switch to local control.

Tip: The lock switches are below the **TILT** and **PAN** drag knobs, as shown in **Figure 5**.

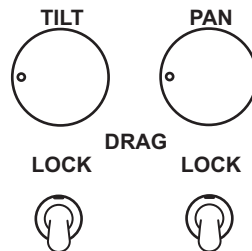

Figure 5 - Tilt and Pan Lock Switches, in the Unlocked Position

3. Without touching the joystick on the local control box, flip the **LOCAL/REMOTE** switch to **LOCAL** and then wait at least two seconds for the local control box to take control of the pedestal system.

After you flip the switch, the green **LOCAL** LED illuminates, and the local control box starts sending data and calibrating.

IMPORTANT: You must **NOT** touch the joystick for at least two seconds after switching to **LOCAL** control mode. The system calibrates the joystick based on its position, so if it is not at a neutral (untouched) position, the calibration will be inaccurate. This could cause the pedestal to move independently in an uncontrolled manner. If this happens, switch back to **REMOTE** mode.

You can now control the camera system manually using the local control box and pan bars.

In SmartShell, the following message appears:

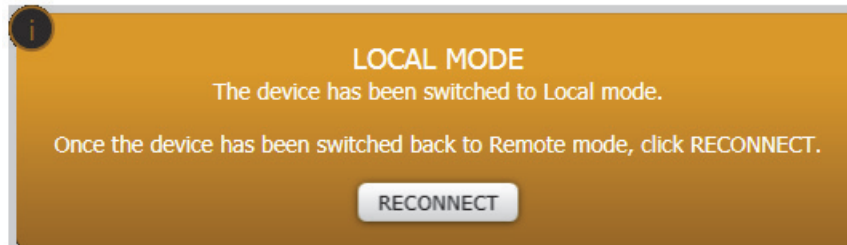

Figure 6 - LOCAL MODE Message, Indicating that the CamBot XY Pedestal is under Local Control

To Switch from Local Control to Remote Control

1. Flip the **LOCAL/REMOTE** switch to the **REMOTE** (bottom) position.

The yellow LED illuminates.

IMPORTANT: After you switch to remote control, do not attempt to move the camera system using pan bars.

2. Wait ten seconds for the local control box to release control of the camera system.

IMPORTANT: Do not switch back to local control until after ten seconds has elapsed. Otherwise, the joystick may not calibrate correctly and the pedestal may immediately start to drift. If this happens, switch back to remote control, wait ten seconds, and then switch to local control.

3. In SmartShell, tap **RECONNECT**.

The **OPERATE** button appears.

4. Click **OPERATE** to take control of the camera system.

You can now control the camera system using SmartShell and the joystick panel.

Moving the Pedestal Across the Studio Floor

The joystick on the local control box enables you to drive the pedestal.

To drive the pedestal:

- Press and hold the joystick button, and then steer the pedestal by pushing the joystick.
Tip: Steering directions are relative to the orientation of the head (pan-relative). When you move the joystick forward, the pedestal moves in the direction the camera is facing.
Tip: Depending on how your system is configured, you may not need to press and hold the joystick button to move the pedestal.

Raising and Lowering the Lift Column

You can use the joystick on the local control box to raise and lower the lift column.

To raise or lower the lift column:

- Twist the joystick counter-clockwise to raise the lift column, or clockwise to lower it.

Panning and Tilting the Head

You can use the pan bars to pan and/or tilt the head.

To pan and/or tilt the head:

1. Ensure the tilt and pan lock switches are in the correct positions:
 - If you want to be able to pan and tilt the head freely, ensure both switches are in the unlocked (downward) position.
 - If you want to restrict movement of either pan or tilt, ensure the corresponding switch is in the locked (upward) position.

Tip: The lock switches are below the **TILT** and **PAN** drag knobs, as shown in **Figure 5**.

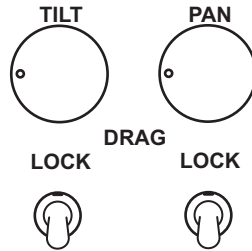

Figure 7 - Tilt and Pan Lock Switches, in the Unlocked Position

IMPORTANT: NEVER try to force the head to move in a locked direction. For example, if the pan lock switch is locked, do not pan. You must unlock the pan switch before you pan. Forcing the head to move in a locked direction can seriously damage the equipment.

2. Use the pan bars to pan and/or tilt the head.

Tip: You can adjust the amount of resistance you feel when you pan and tilt. For more information, see “**Adjusting Drag for Pan and/or Tilt**” on page 3-20.

Adjusting Drag for Pan and/or Tilt

You can use the **TILT** and **PAN** drag knobs to adjust the amount of resistance you feel when you pan and tilt.

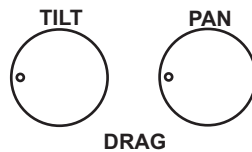

Figure 8 - TILT and PAN Drag Knob s

To adjust the drag for pan and/or tilt:

- Turn the **TILT** knob to adjust tilt drag, or the **PAN** knob to adjust pan drag.

Tip: Turning the knobs clockwise increases drag. Turning them counter-clockwise decreases drag.

Locking and Unlocking Tilt and/or Pan

You can lock tilt and/or pan to prevent movement in one direction. For example, if you want to pan smoothly without any tilt motion, you can lock tilt.

You can also lock both tilt and pan to keep the camera system in its current position. This allows you to set up a stationary camera shot and step away, while maintaining local control to prevent any other control system from moving the camera.

Note: The tilt and pan locks affect only local control. They do not affect the ability of the SmartShell application or an automation system to move the head when the camera system is in remote control mode.

To lock or unlock tilt and/or pan:

- Flip the desired lock switch to the locked (upwards) position, or unlocked (downwards) position.

Tip: The tilt lock switch is below the **TILT** drag knob. The pan lock switch is below the **PAN** drag knob.

Figure 9 shows the tilt and pan lock switches.

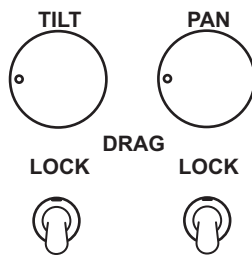

Figure 9 - Tilt and Pan Lock Switches (Below TILT drag knob and PAN drag knob)

Rotating the Pedestal

You can use the joystick on the local control box to rotate the pedestal. Rotating the pedestal is useful when targeting a pedestal, or to prepare to drive it across the studio floor.

To rotate the pedestal:

- Press the **ROTATE** button and then twist the joystick the direction you want the pedestal to rotate. **Figure 10** shows the **ROTATE** button.



Figure 10 - The ROTATE Button

Targeting a CamBot Pedestal

You must target pedestals each time you turn them on. To maintain shot accuracy, it is also good practice to re-target pedestals regularly. Broadcasters typically re-target pedestals once per day, or before each show.

To target a pedestal, you move it into position over the CamBot target and then use the SmartShell control application to request targeting. The pedestal determines its location on the studio floor by observing markings on the target.

For information about positioning and installing a CamBot target, see “**Installing a CamBot Target**” on page 4–24.

To target a CamBot pedestal:

1. If the pedestal is not already running, turn it on.
The pedestal takes approximately one minute to initialize.
2. In SmartShell, select the camera (pedestal) you want to target.
3. Do one of the following to move the pedestal into the target position:
 - If you are re-targeting a pedestal that has not been turned off since targeting, and there is a preset (shot) representing the target position, recall that preset.
 - Use the joystick panel controls to position the pedestal over the target such that the front edge of the pedestal points toward the set, and the back edge of the pedestal is aligned with the **180° side** of the target. See **Figure 11**, below.
 - Use the local control box (optional accessory) to position the pedestal over the target such that the front edge of the pedestal points towards the set, and the back edge of the pedestal is aligned with the **180° side** of the target. See **Figure 11**, below.

After you position the pedestal, ensure the control switch is set to **REMOTE** before you continue.

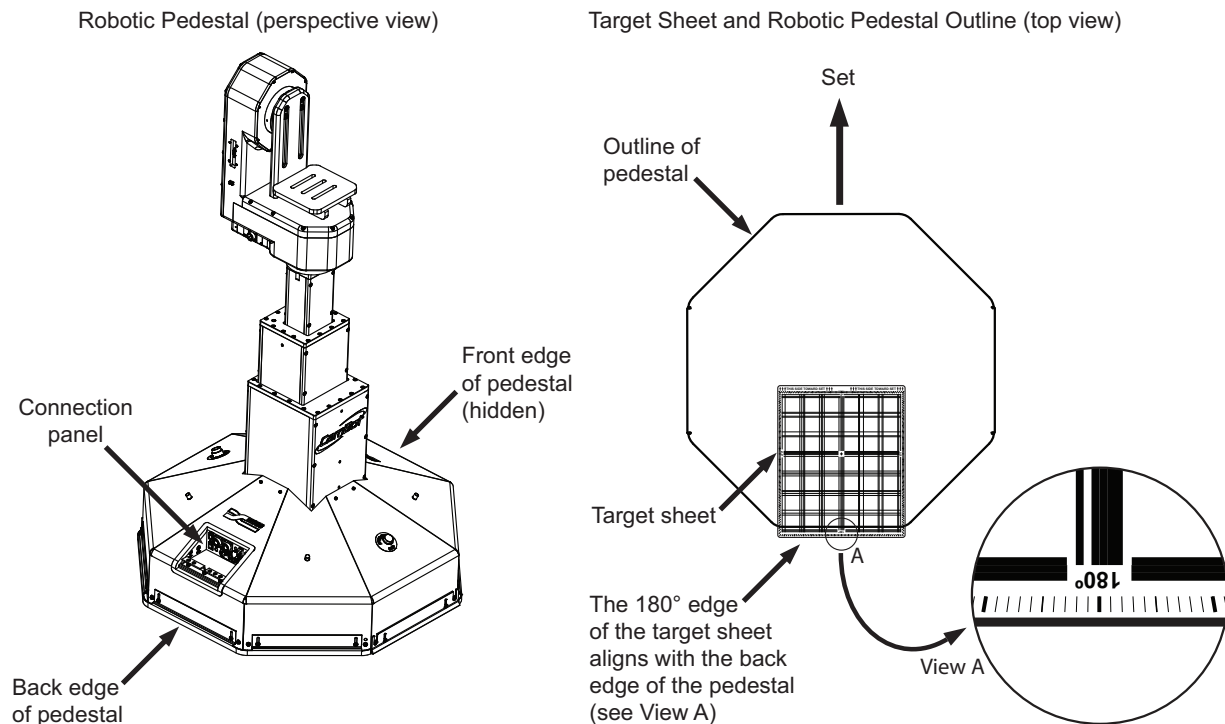

Figure 11 - Positioning the CamBot Pedestal Over the Target

Note: The pedestal does not need to align perfectly with the target. Some operators find it easier to position pedestal such that the target extends slightly beyond the back edge of the pedestal.

4. In SmartShell, on the **Axis Control** panel, select the **XY** axis from the axis list.
5. In SmartShell, click or tap the **TARGET** button.

When prompted, confirm that you want to target the pedestal.

Tip: The first time you target each pedestal, create a preset (shot) at that position. In SmartShell, create the preset and then edit it to select the **Auto Rotate Pedestal** option. Anytime you want to target that pedestal, you can recall the preset to properly position the pedestal over the target sheet. You can also recall the preset to park the pedestal between shows, to make targeting before the next show even easier.

Maintenance

CamBot XY Pedestals are designed to require very little maintenance.

This section contains the following topics about maintaining CamBot XY Pedestals:

- “**General Inspection and Cleaning**” on page 4–23
- “**Installing a CamBot Target**” on page 4–24
- “**Cleaning CamBot XY Pedestal Wheels**” on page 4–25
- “**Replacing Pneumatic Struts**” on page 4–35

General Inspection and Cleaning

The CamBot XY Pedestal is designed to require almost no regular maintenance.

Perform the following inspection and cleaning tasks periodically:

- Clean the pedestal and robotic head.
 - Turn off the robot and then use a slightly water-dampened rag and a mild liquid detergent to clean the pedestal and the head.
 - Do not use abrasive cleansers or chemical solvents!
 - Do not get any connectors wet!
 - Ensure that the robot is completely dry before turning it back on!
- Inspect cables for damage
 - Inspect the bundle of cables that extends from the robot, looking for signs of excessive wear on the cable sleeve.
 - If the cable sleeve is damaged, inspect the cables to ensure that no conductors are exposed or damaged. Replace any damaged cables or cable sleeves promptly. Do not operate the robot if any conductors are exposed!
 - Inspect all points where cables connect to the pedestal, the head, or the payload. Make sure that the connectors are mated properly.
 - Check that all cables are properly dressed, so that strain on connectors is eliminated as much as possible, and that the cables have adequate slack to allow for the full range of robotic motion.
- Check the mounting bolts
 - Periodically check that the bolts holding the payload together are tight. Also check the bolts that fasten the payload to the camera cradle, the bolts that fasten the camera cradle to the head, and the bolts that fasten the head to the lift column. Checking the mounting bolts is especially important in the first few weeks after installing the payload.
- Check cable kicker height
 - Around the base of the pedestal, metal strips called “cable kickers” ensure that when the pedestal moves across the studio floor, it pushes cables aside rather than running over them. **Figure 1 on page 2–10** shows the cable kickers.
 - The cable kickers should be set to the lowest height possible that does not result in the kickers themselves contacting the studio floor.
 - To check cable kicker height, drive the pedestal to all areas of the studio while observing the clearance between the cable kickers and the floor.
 - If necessary, the height of the cable kickers is easily adjusted using a screwdriver. Generally, the height of the cable kickers does not require adjustment after initial setup.
- Inspect wheels for dirt and debris
 - As wheels roll across the studio floor, they accumulate dirt and debris. Accumulation of debris on the wheels can impair smooth motion.
 - Visually inspect the wheels to detect the presence of foreign material.
 - If the wheels require cleaning, follow the directions in the section, “**Cleaning CamBot XY Pedestal Wheels**” on page 4–25.

- Clean and inspect the CamBot target

Use a slightly water-dampened rag and a mild liquid detergent to clean the CamBot target. Do not use abrasive cleansers or chemical solvents! Ensure that the target is completely dry before driving the pedestal over it.

Installing a CamBot Target

CamBot targeting is based on optical pattern recognition technology that requires zero maintenance, provides millimeter accuracy and takes less than a second to complete.

The CamBot target is a thin plastic sheet with markings that enable CamBot robotic pedestals to confirm their absolute position on the studio floor.

This section describes how to position and install a CamBot target.

For information about targeting a CamBot pedestal, see “**Targeting a CamBot Pedestal**” on page 3–21.

To position and install the target:

1. Select a location for the target.

The target can be installed anywhere on the studio floor, as long as there is space for pedestals to drive around the target. Typically, there is one target for each pedestal.

Tip: The target should not be installed in a location where the pedestal will normally operate during shows. This is because driving over the raised target may cause unwanted vibration in the shot.

2. Clean the floor where you want to install the target. The floor must be clean and completely dry.
3. Position the **0° side** of the target toward the set (see **Figure 1**).

Note: The target must be square to the set, meaning that the **0° side** of the target must be perfectly parallel with the right-left axis of the set. This is critical for proper steering when using the joystick panel.

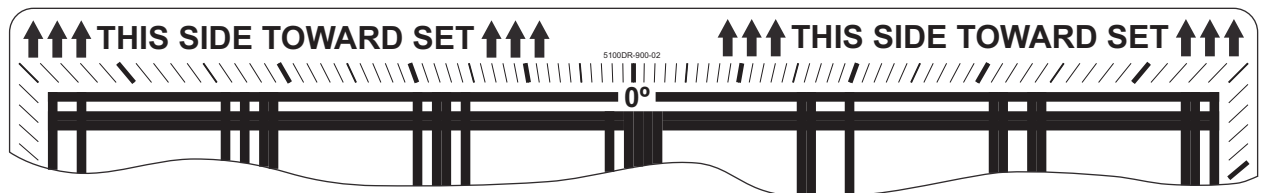

Figure 1 - CamBot Target - Must be Square to the Set, with the 0° Side Facing Toward the Set

4. If you want to install the target temporarily, or want to experiment with the position before installing the target permanently, use gaffer tape to stick the edges of the target to the floor.

Tip: The target will still work if the degree markings (slashes) along its edges are covered.

Note: Ensure that the tape leaves no sticky residue exposed, either beside or on top of it. Tape residue can stick to the pedestal wheels, impairing smooth motion.

5. When you are ready to install the target permanently, do the following:
 - a. Use narrow gaffer tape to precisely mark the floor position of the **0° side** and two adjacent corners of the target.
 - b. Peel the backing off of the target.
 - c. Carefully align the **0° side** of the target with the tape marks, and then stick the target to the floor, starting at the aligned side. Press firmly as you apply the target, to ensure there are no air bubbles under it.

Cleaning CamBot XY Pedestal Wheels

As wheels roll across the studio floor, they accumulate dirt and debris. Cleaning the wheels periodically helps maintain the smooth motion and positional accuracy required for flawless moving shots.

This section describes how to clean the wheels of CamBot XY Pedestals. It includes the following topics:

- **“Preparation”** on page 4-25
- **“Propping up the Pedestal Base”** on page 4-26
- **“Lifting the Pedestal Skirt”** on page 4-29
- **“Cleaning the Wheels”** on page 4-32
- **“Scraping the Wheels”** on page 4-33
- **“Reassembling the CamBot XY Pedestal”** on page 4-35

Note: For optimal performance, especially with moving shots, it's important to keep the pedestal wheels clean. Sweep and mop the studio floor regularly. Avoid moving CamBot XY Pedestals across a dirty floor. Periodically replace worn spike marks with new spike tape, and remove all old tape residue from studio floors.

Preparation

To clean the wheels, the following tools are required:

- 3/32" hex key (also known as a hexagonal wrench, or Allen key)
- 5/32" hex key
- A pry bar
- Four wooden prop blocks, approximately 12" (30cm) long and 2" (5cm) on each side. Pieces of 2" nominal lumber can be used (2"x2", 2"x3", or 2"x4").
- Four small pieces of thin plywood, minimum 3" x 3" x 0.25 thick" (7.5cm x 7.5cm x 0.6cm thick).
- Two wooden supports, approximately 36" (90cm) long and 2" (5cm) on each side. Pieces of 2" nominal lumber can be used (2"x2", 2"x3", or 2"x4").
- A new single edge razor blade
- Protective gloves
- Mild liquid detergent. DO NOT use harsh chemical cleaners such as ammonia. Harsh chemicals can damage the wheels.
- A clean bucket, a rag, and access to warm water.
- Plastic scrubbing pads, such as ScotchBrite #7447, 7448, or similar. DO NOT use steel wool or other abrasive tools that can damage the wheels.
- A vacuum cleaner with attachments for reaching into small spaces.

Note: For some parts of the cleaning process, two people are required.

Before you begin:

1. Move the pedestal to a clean area of the studio floor away from any CamBot targets. Ensure that there is ample working space all around the pedestal.
2. Ensure that the payload is balanced, to prevent the possibility of tipping.
3. Press the **Stop** switch on the connection panel to turn off the pedestal.

Propping up the Pedestal Base

To fully expose the wheels for cleaning, we recommend that you prop up the pedestal base so the wheels spin freely. This makes it easier to access the wheels for cleaning.

This is an optional procedure. If you choose not to prop up the base, you can clean the exposed portion of each wheel and then move the pedestal manually to expose more of the wheel.

The pedestal base has eight sides. Two sides have large drive wheels. Two sides have smaller stabilizing wheels that pivot. The remaining four sides have no wheels.

To prop up the base, you insert four wooden prop blocks beneath it; one prop block on each side of each drive wheel.

To prop up the base:

1. At the connection panel on the pedestal, disconnect all cables, keeping track of where each must be reconnected later (see **Figure 2**).
2. Note the height of the bumpers and cable kickers (see **Figure 2**).

Tip: You can use a grease pencil to mark the positions of the bumpers and cable kickers on the pedestal skirt.

3. Raise the bumpers and cable kickers to the highest position:
 - a. Use a 3/32" hex key to loosen the screws that fasten the bumpers and cable kickers to the pedestal skirt. Each of the two bumper assemblies has six screws. Each of the two cable kickers has two screws. Loosen the screws just enough to allow the bumpers and cable kickers to move (see **Figure 2**).
 - b. Raise the bumpers and cable kickers to the highest position, and then tighten the screws just enough to hold the pieces in position. Do not over-tighten.

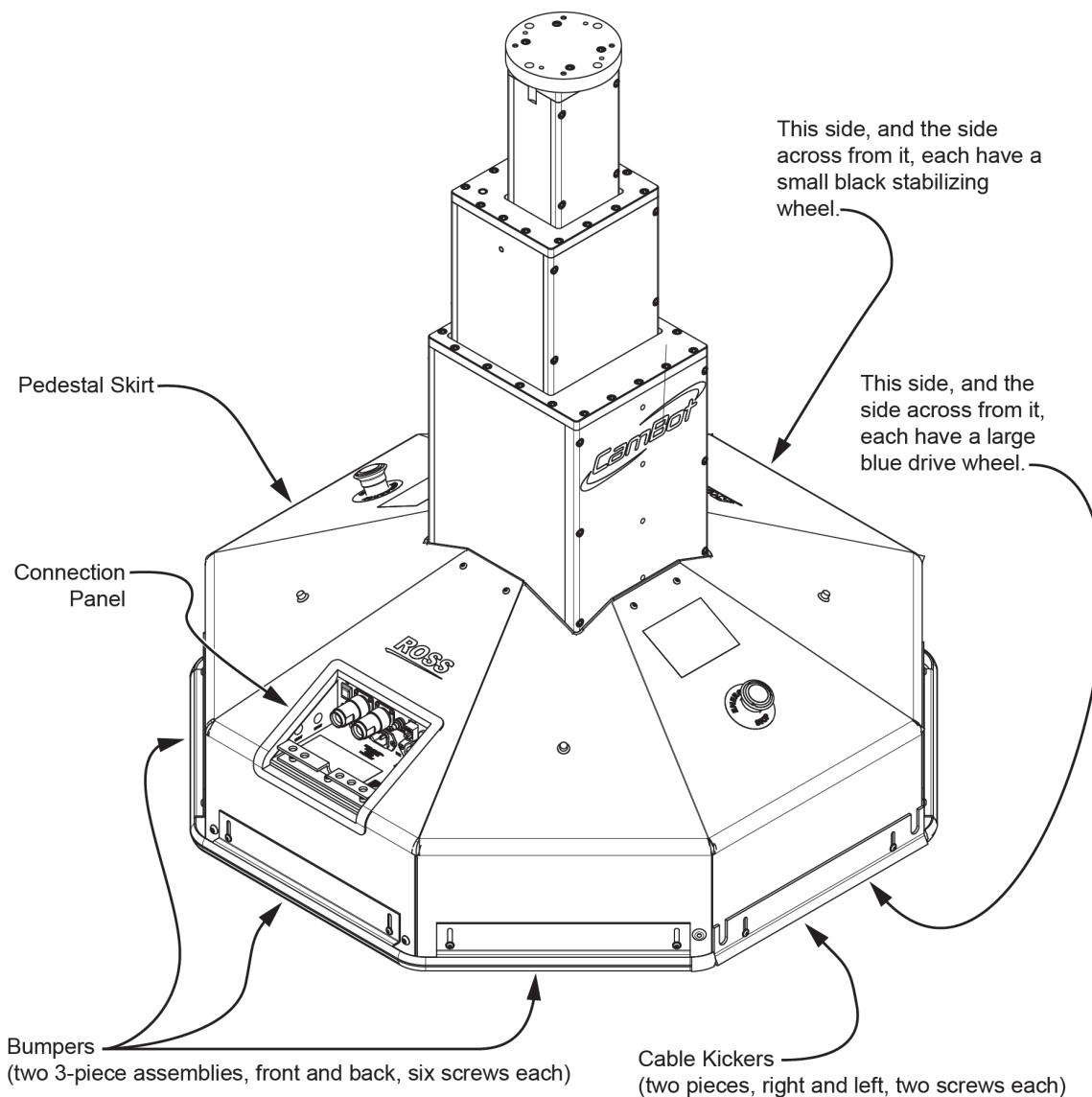

Figure 2 - Raising the Bumpers and Cable Kickers (CamBot 700XY pedestal shown)

4. Prop up the pedestal base on each side of a drive wheel:

- a.** On a side of the base that has no wheels (see **Figure 2**), use a pry bar to lift the base, and then insert a prop block beside the adjacent drive wheel, as shown in **Figure 3**.

Tip: Before you pry, protect the studio floor from damage by placing a small piece of thin plywood under the pry bar.

IMPORTANT: Ensure that the pry bar does not contact the drive wheels, the bumpers, the cable kickers, or the pedestal skirt. It should contact only the plywood and the bottom of the pedestal base.

IMPORTANT: Be careful to avoid contacting or damaging the nylon screws that extend below the base plate (see **Figure 3**).

WARNING: The pedestal is very heavy. DO NOT allow it to slip and crush your fingers.

WARNING: To avoid tipping, DO NOT lift the edge of the pedestal more than 2 inches (5cm).

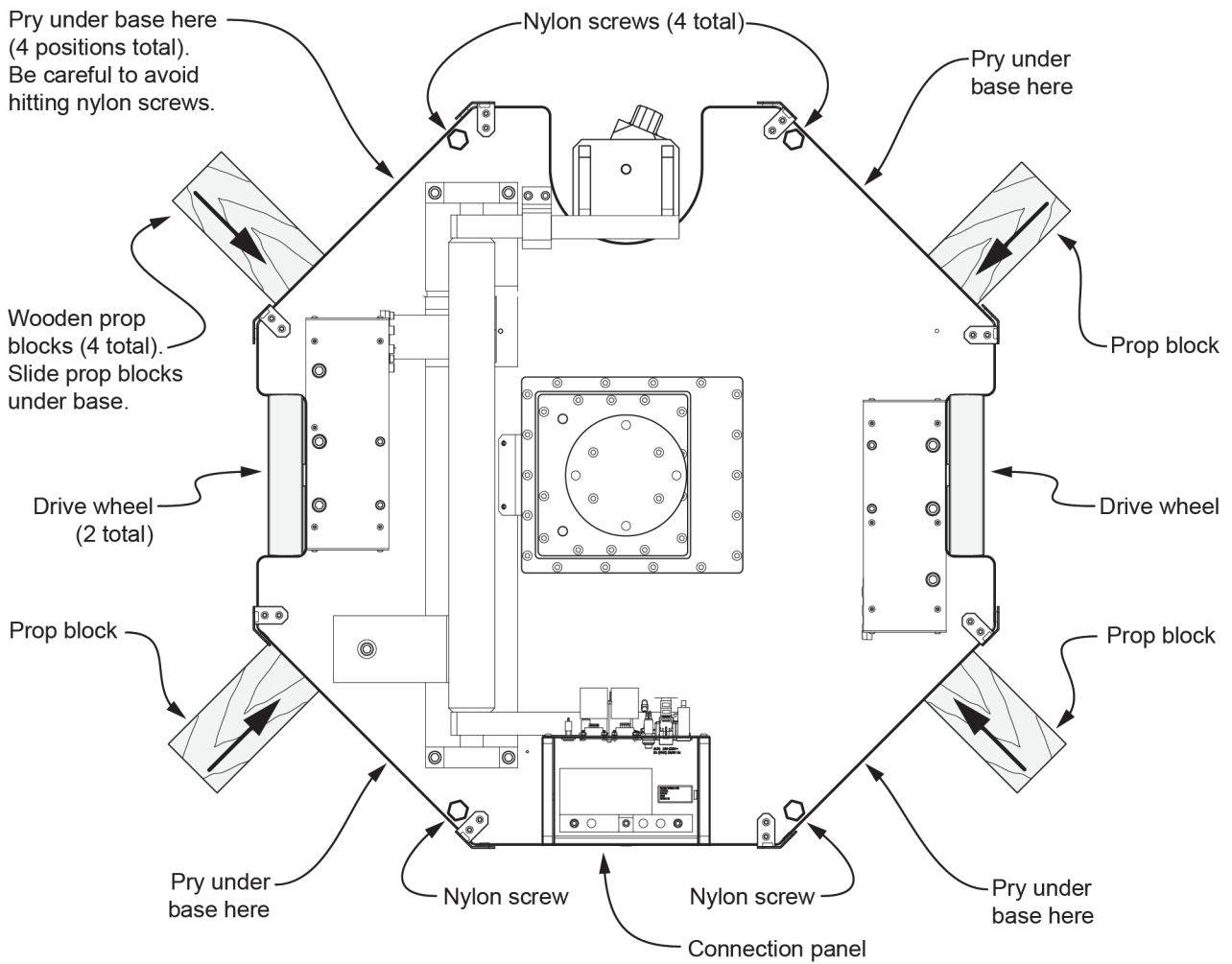

Figure 3 - Propping up the Pedestal Base - Simplified Top View of Pedestal (skirt and some other parts omitted for clarity)

- b. Repeat **Step Step 4Step a** on the other side of the same drive wheel.
The drive wheel is suspended, and spins freely.
5. Repeat **Step Step 4** for the other drive wheel.

Lifting the Pedestal Skirt

To expose the wheels for cleaning, you must lift the pedestal skirt.

Note: This procedure requires two people.

To lift the skirt:

1. Along the top edge of the skirt, use a $3/32$ " hex key to remove the eight screws that secure the skirt to the lift column (if present). See **Figure 4**.

Note: Some CamBot XY pedestals do not have screws along the top edge of the skirt.

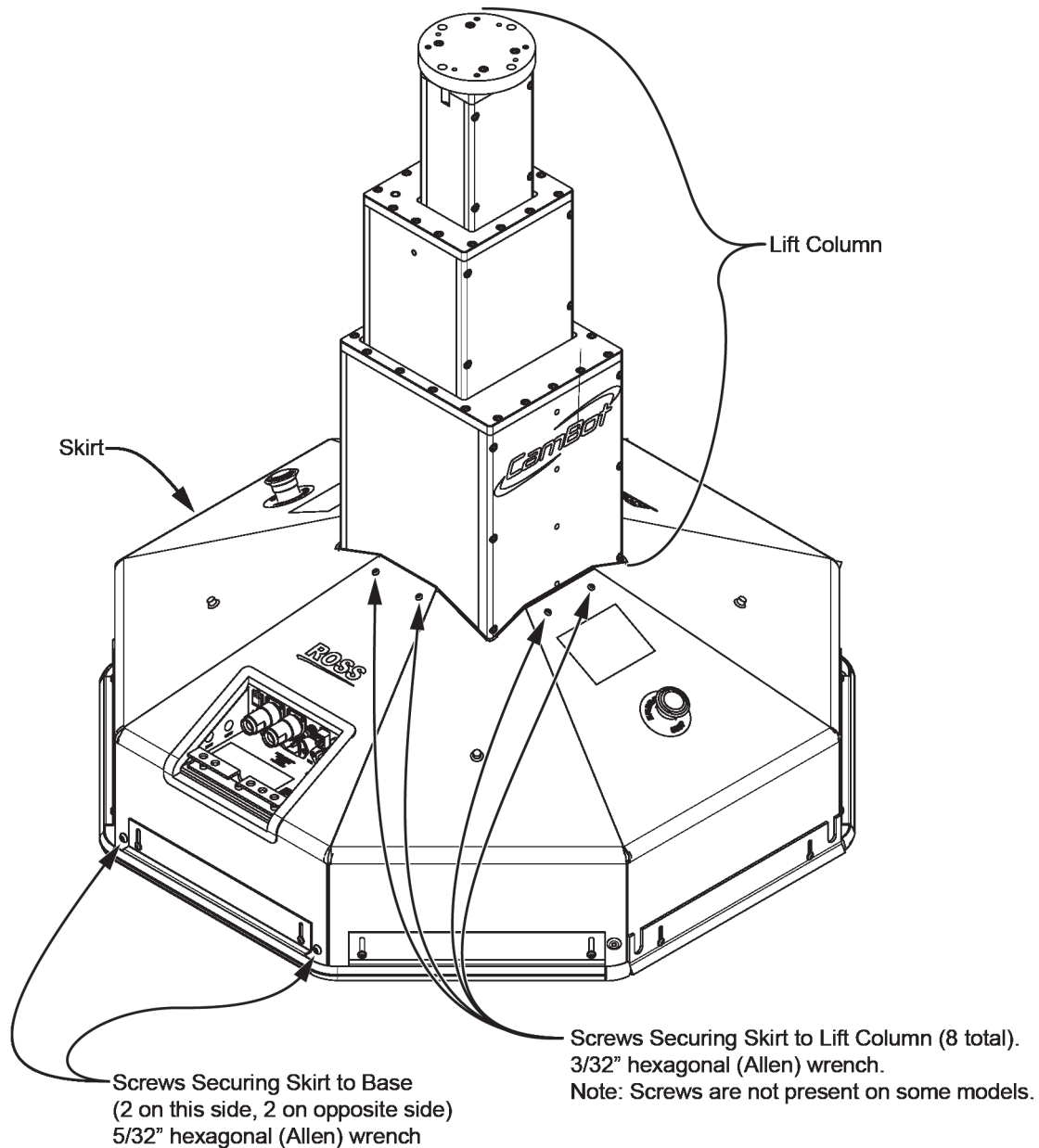

Figure 4 - CamBot 700XY Pedestal, showing Screws that Secure the Skirt

2. At the bottom of the skirt, use a $5/32$ " hex key to remove the four screws that secure the skirt to the pedestal base plate (see **Figure 4**).
3. Bring the two 36" (90cm) wooden support pieces to within easy reach of the pedestal for the next step.

4. With one person on each side of the pedestal, slowly lift the skirt approximately 10 inches (25cm) and then slide the support pieces under the skirt so they rest on the rectangular blocks beside the large blue drive wheels. Lower the skirt onto the support pieces, as shown in **Figure 5**.

IMPORTANT: When you insert the support pieces, avoid snagging or pinching any cables under the skirt. Slide the support pieces in from the side, not lengthwise (see **Figure 5**).

IMPORTANT: Depending on the model of pedestal, there may be a green ground wire that spans between the base (near the connection panel) and the edge of the skirt. This wire may become tight or it may disconnect entirely. If it becomes disconnected, reconnect it.

Tip: To prevent binding, avoid tilting the skirt as you lift it.

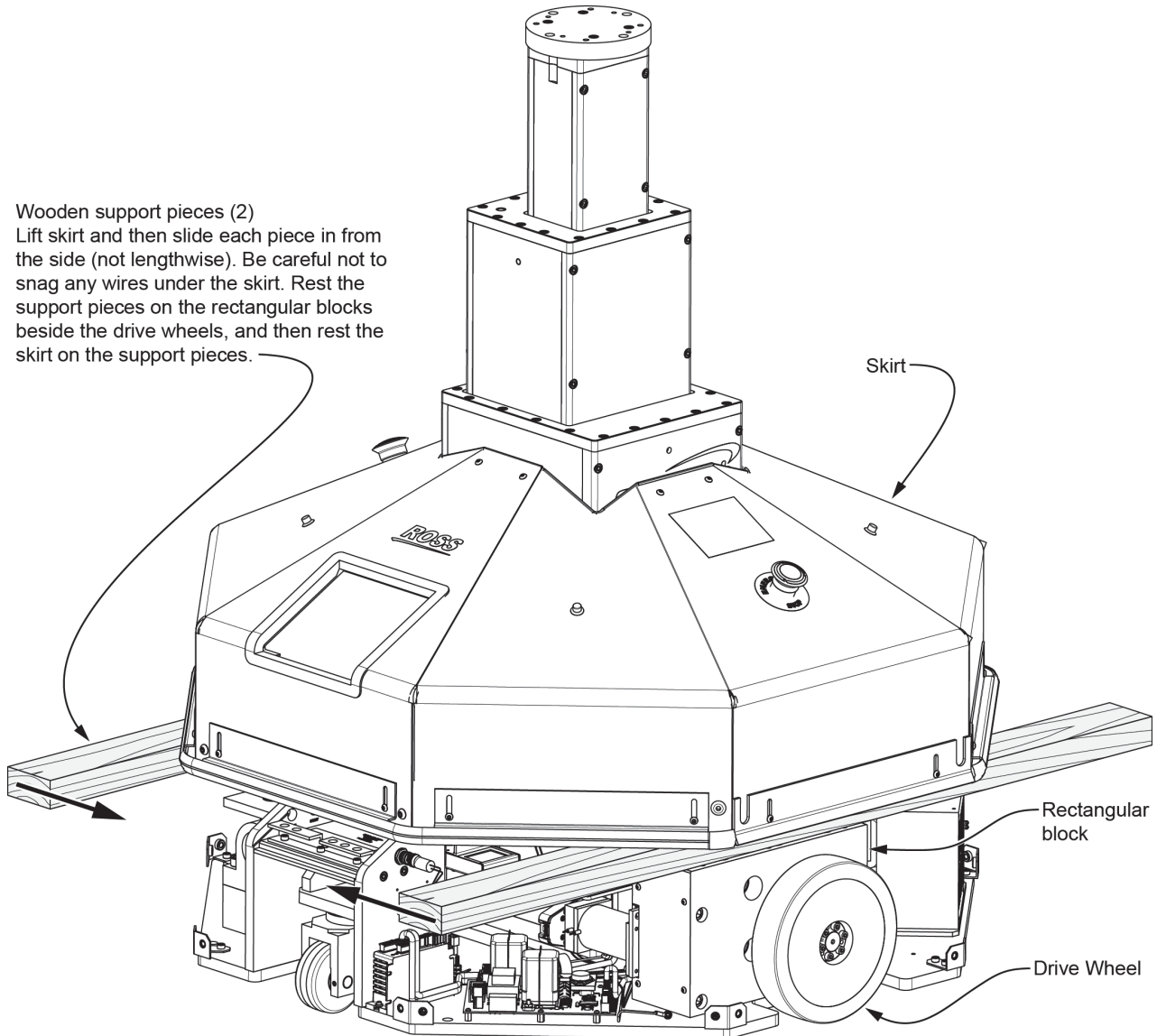

Figure 5 - Lifting and Supporting the Pedestal Skirt (CamBot 700XY pedestal shown)

5. To the right side of the connection panel, check whether there is a loose green ground wire hanging from the inside edge of the skirt. If such a wire is present, reconnect it. The wire connects to a similar green ground wire attached to a threaded post beside the connection panel. See **Figure 6**.

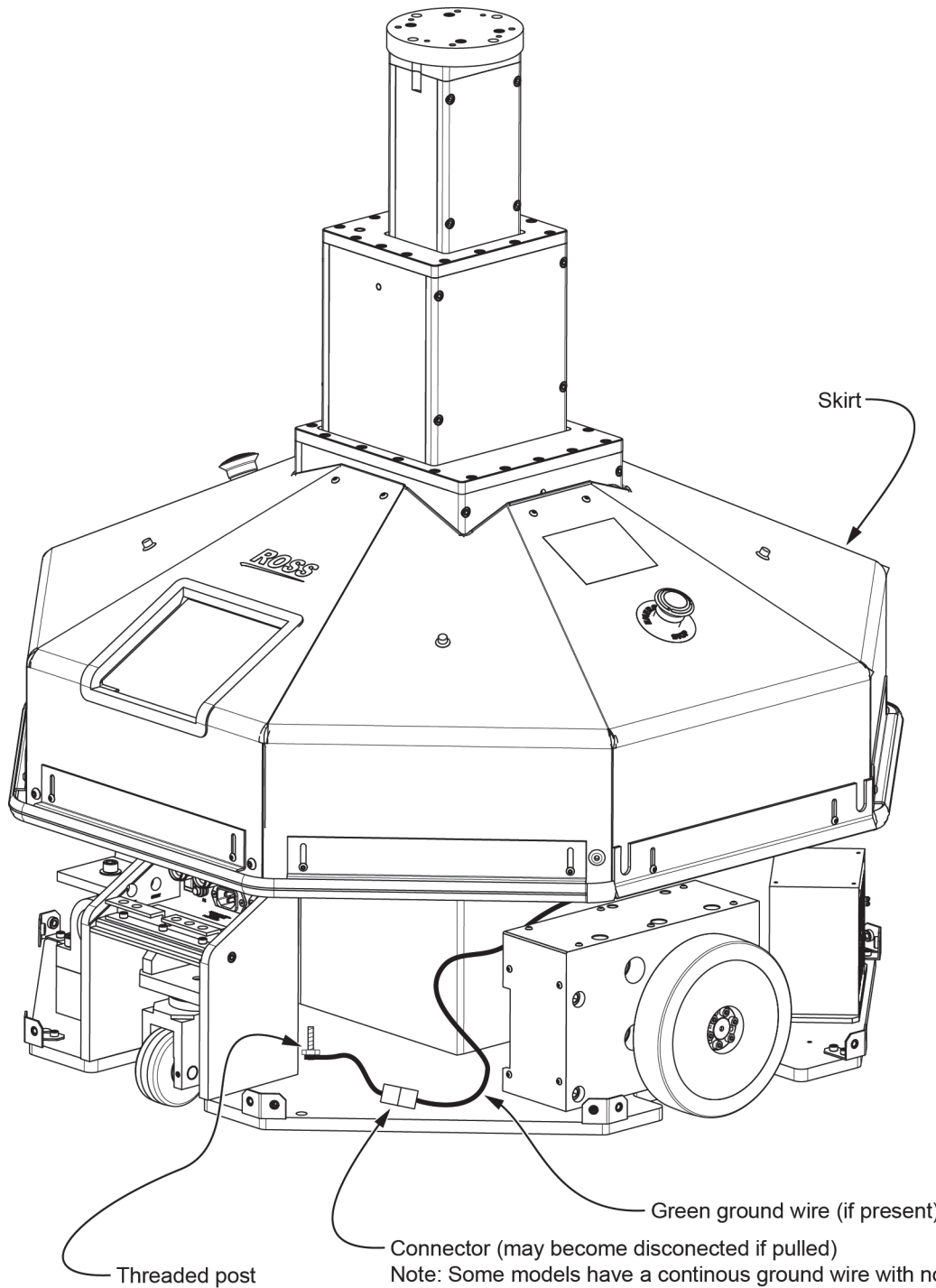

Figure 6 - Reconnecting the Green Ground Wire (if present) - View of the CamBot 700XY Pedestal (some parts omitted for clarity)

Cleaning the Wheels

To clean the wheels:

1. Put on protective gloves, and then clean all four wheels using a plastic scrubbing pad, warm water, and mild detergent, such as dish detergent.

IMPORTANT: DO NOT use harsh cleaning agents on the wheels. Harsh chemicals or solvents such as acetone can seriously and permanently damage wheel material. Use only a mild detergent, such as dish detergent.

IMPORTANT: Wear protective gloves. Debris on the wheels may be sharp. Glass shards from broken bulbs may be embedded in the wheels.

Note: If you did not prop up the base, clean the exposed portion of each wheel and then move the pedestal manually to expose more of the wheel.

2. Check the sides of the small stabilizing wheels for string, hair, and other debris wrapped around the axles. Remove all such debris and check that the wheels turn freely.

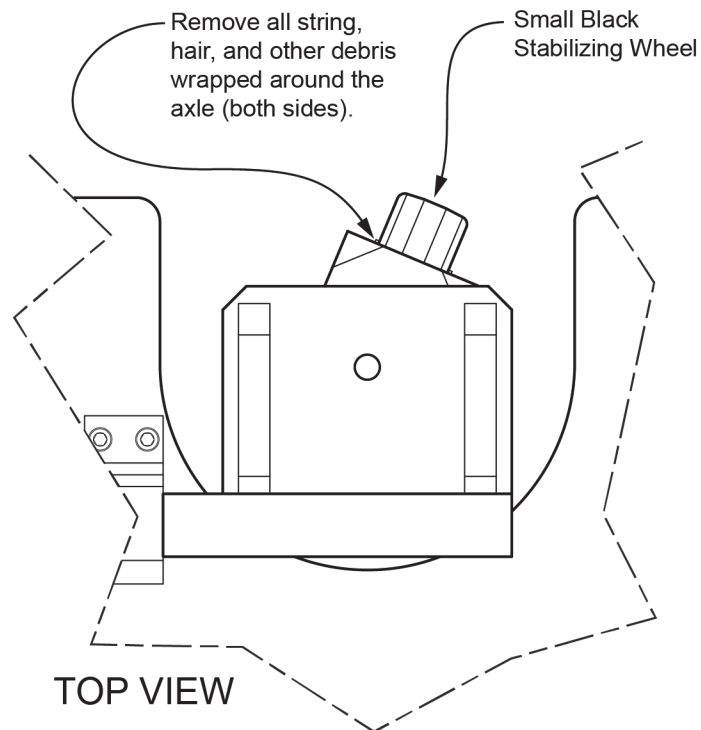

Figure 7 - Removing String, Hair, and Other Debris from Axles of Stabilizing Wheels (top view)

3. On top of the pedestal base plate, near the drive wheels, use a vacuum cleaner to remove all dirt and debris. Then use a clean damp rag to clean the top of the base plate near the drive wheels.

IMPORTANT: Do not spill water on any electronic components.

4. Use a clean damp rag to clean the floor around the wheels.

5. If you propped up the pedestal base, do the following:

- On each side of the pedestal base that has a prop block, use a pry bar to lift the base, remove the prop block, and then gently lower the pedestal base.

Tip: Before you pry, protect the studio floor from damage by placing a small piece of thin plywood under the pry bar.

IMPORTANT: Ensure that the pry bar does not contact the drive wheels, the bumpers, the cable kickers, or the pedestal skirt. It should contact only the plywood and the bottom of the pedestal base.

IMPORTANT: Be careful to avoid contacting or damaging the nylon screws that extend below the base plate (see **Figure 3**).

WARNING: The pedestal is very heavy. DO NOT allow it to slip and crush your fingers.

WARNING: To avoid tipping, DO NOT lift the edge of the pedestal more than 2 inches (5cm).

IMPORTANT: Each drive wheel has two prop blocks beside it. Remove the two prop blocks for one wheel, and then for the other.

Scraping the Wheels

CamBot XY Pedestal wheels are designed to be somewhat soft to ensure that very minor bumps on the studio floor do not cause vibrations in moving shots. Because the wheels are soft, very small, sharp debris such as broken bulb glass can become embedded in them.

Scraping the wheels removes embedded objects from them.

To scrape the wheels:

1. Put on protective gloves.

IMPORTANT: Wear protective gloves. Debris on the wheels may be sharp. Glass shards from broken bulbs may be embedded in the wheels.

2. Scrape each of the four wheels as follows:

- Holding a razor blade perpendicular to the wheel surface, scrape the exposed surface of the wheel to remove embedded debris. See **Figure 8**.

WARNING: Razor blades are extremely sharp! Be very careful to avoid cutting yourself or others!

IMPORTANT: Be very careful to avoid cutting the wheel! Always keep the razor blade perpendicular to the wheel surface! Do not tilt the razor blade! Do not push the razor blade into the wheel material!

WARNING: Razor blades are sharp!
Be careful not to cut yourself!

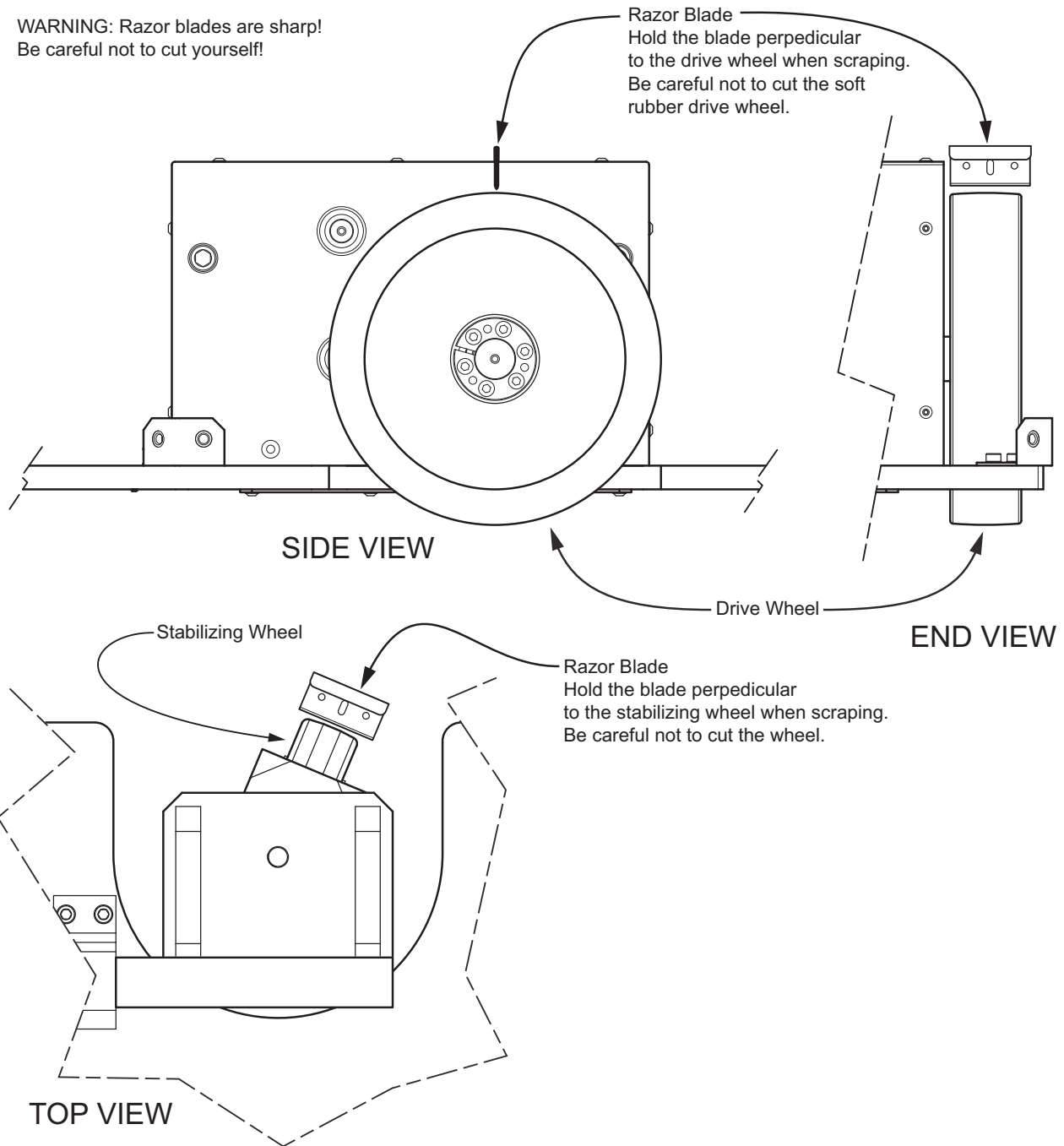

Figure 8 - Scraping the Wheels to Remove Embedded Debris

3. After you have scraped the exposed surfaces of the wheels, clean up any debris on the floor around them, and then move the pedestal to expose unscraped portions of the wheels' surface.
4. Repeat **Steps Step 2 and Step 3** as required.

Reassembling the CamBot XY Pedestal

Note: This procedure requires two people.

To reassemble the CamBot XY Pedestal:

1. With one person on each side of the pedestal, lift the skirt slightly, remove the wooden support pieces, and then lower the skirt gently onto the pedestal base.

Align the skirt carefully to ensure that the corner brackets on the pedestal base are beneath the skirt.

WARNING: Be careful not to pinch your fingers between the skirt and the pedestal base.

WARNING: Be careful not to drop the skirt. A falling skirt can damage components on the pedestal base.

IMPORTANT: If you lift the skirt too high, the green ground wire (if present) may become disconnected. If this happens, reconnect the wire before lowering the skirt. See **Figure 6**.

Tip: To prevent binding, avoid tilting the skirt as you lower it.

2. At the top of the skirt, use a 3/32" hex key to reattach the eight screws that secure the skirt to the lift column (if present).

IMPORTANT: Make sure the holes in the skirt are fully aligned with the screw holes before you insert the screws. Be careful not to cross-thread the screws. Do not over-tighten the screws.

Note: Some CamBot XY pedestals do not have screws along the top edge of the skirt.

3. At the bottom of the skirt, use a 5/32" hex key to reattach the four screws that secure the skirt to the pedestal base plate.

IMPORTANT: Make sure the holes in the skirt are fully aligned with the screw holes before you insert the screws. Be careful not to cross-thread the screws. Do not over-tighten the screws.

4. Lower the bumpers and cable kickers to their original positions:

- a. Use a 3/32" hex key to loosen the screws that fasten the bumpers and cable kickers to the pedestal skirt. Each of the two bumper assemblies has six screws. Each of the two cable kickers has two screws. Loosen the screws just enough to allow the bumpers and cable kickers to move.
- b. Lower the bumpers to their original position, and then tighten the bumper screws to secure the bumpers. Do not over-tighten.

The bumpers prevent the pedestal from running over cables. The bumpers should be set as low as possible, but must not bottom out as the pedestal moves across the studio floor.

5. Reconnect cables to the connection panel as required. Dress the cables to protect them. Be sure to allow enough slack to accommodate the full range of pan, tilt, and lift motion.

Replacing Pneumatic Struts

Each CamBot XY Pedestal contains one or two pressurized pneumatic struts that help support the weight of the payload. Struts of various force ratings are available from Ross Video. If you change the weight of the payload, you may require different struts.

After years of regular use, struts may become less efficient and may need to be replaced. The payload should maintain its position when you turn off the pedestal. If the payload drops significantly, the struts are underpowered, either because their ratings are not appropriate for the payload, or because they are worn out.

This section describes how to determine the suitable strut model for your payload, and how to remove and install the strut(s). The strut replacement procedure varies between pedestals that have a two-stage lift (600XY-S2 pedestal), and those that have a three-stage lift (600XY-S3 and 700XY pedestals).

This section includes the following topics:

- **“Selecting Appropriate Struts”** on page 4–36
- **“CamBot XY Pedestal with Three-Stage Lift — Replacing Struts”** on page 4–37
This applies to pedestal models 600XY-S3 and 700XY.
- **“CamBot XY Pedestal with Two-Stage Lift — Replacing the Strut”** on page 4–43
This applies to pedestal model 600XY-S2.

Selecting Appropriate Struts

The exact model of strut(s) required for a CamBot XY Pedestal depends on the model of pedestal and the payload it carries.

Table 1 lists the correct struts for each pedestal model and payload.

Table 1 - - Selecting Appropriate Struts

Pedestal Model	Payload Weight	Strut Order Numbers
600XY-S2 Requires one strut only.	0 to 45 lbs 0 to 20 kg	CAM-610ST-450N
	45 lbs to 80 lbs 20 kg to 36 kg	CAM-610ST-550N
	80 lbs to 125 lbs 36 kg to 57 kg	CAM-610ST-715N
	Over 125 lbs over 57 kg	Payload is too high!
600XY-S3 Requires two identical struts. Each strut order number is for a pair of identical struts.	0 to 20 lbs 0 to 9 kg	Payload is too low!
	20 lbs to 70 lbs 9 kg to 32 kg	CAM-610ST-600N-S3
	70 lbs to 125 lbs 32 kg to 57 kg	CAM-610ST-700N-S3
	Over 125 lbs over 57 kg	Payload is too high!
700XY Requires two identical struts. Each strut order number is for a pair of identical struts.	0 to 40 lbs 0 to 18 kg	Payload is too low!
	40 lbs to 100 lbs 18 kg to 45 kg	CAM-710ST-700N
	100 lbs to 125 lbs 45 kg to 57 kg	CAM-710ST-800N
	125 lbs to 150 lbs 57 kg to 68 kg	CAM-710ST-900N
	150 lbs to 170 lbs 68 kg to 77 kg	CAM-710ST-1000N
	170 lbs to 190 lbs 77 kg to 86 kg	CAM-710ST-1100N
	190 lbs to 200 lbs 86 kg to 91 kg	CAM-710ST-1230N
	Over 200 lbs Over 91 kg	Payload is too high!

CamBot XY Pedestal with Three-Stage Lift — Replacing Struts

This section describes how to replace pneumatic struts in a CamBot XY pedestal that has a three-stage lift. This procedure applies to pedestal models 600XY-S3 and 700XY.

The three-stage lift column requires two identical struts. Both struts must be suitable for the model of pedestal and for the payload. For more information, see “**Selecting Appropriate Struts**” on page 4–36.

The struts are installed internally. They extend from indentations in the base plate of the pedestal to the top plate of the lift column’s middle stage. The steps in this section refer to this plate as the “strut plate”.

Replacing the struts requires two people, and takes approximately 45 minutes.

Tools required include 1/8”, 3/16”, and 5/16” hex keys (also known as hexagonal wrenches, or as Allen keys).

To replace the pneumatic struts:

1. Move the pedestal to an open area so you have easy access to all sides.
2. Lower the lift column all the way to allow easy access to the payload.
3. Remove the payload, and then turn the pedestal **OFF**.
4. Do the following to remove the head:
 - a. Disconnect all cables from the head.
 - b. Have someone hold the head steady to prevent it from falling.
 - c. Use a 5/16” hex key to remove the four screws that fasten the head to the lift column. Retain the screws for re-installation later.

Tip: In **Figure 9**, the screws and the holes in the top plate of the lift column are shown as red.

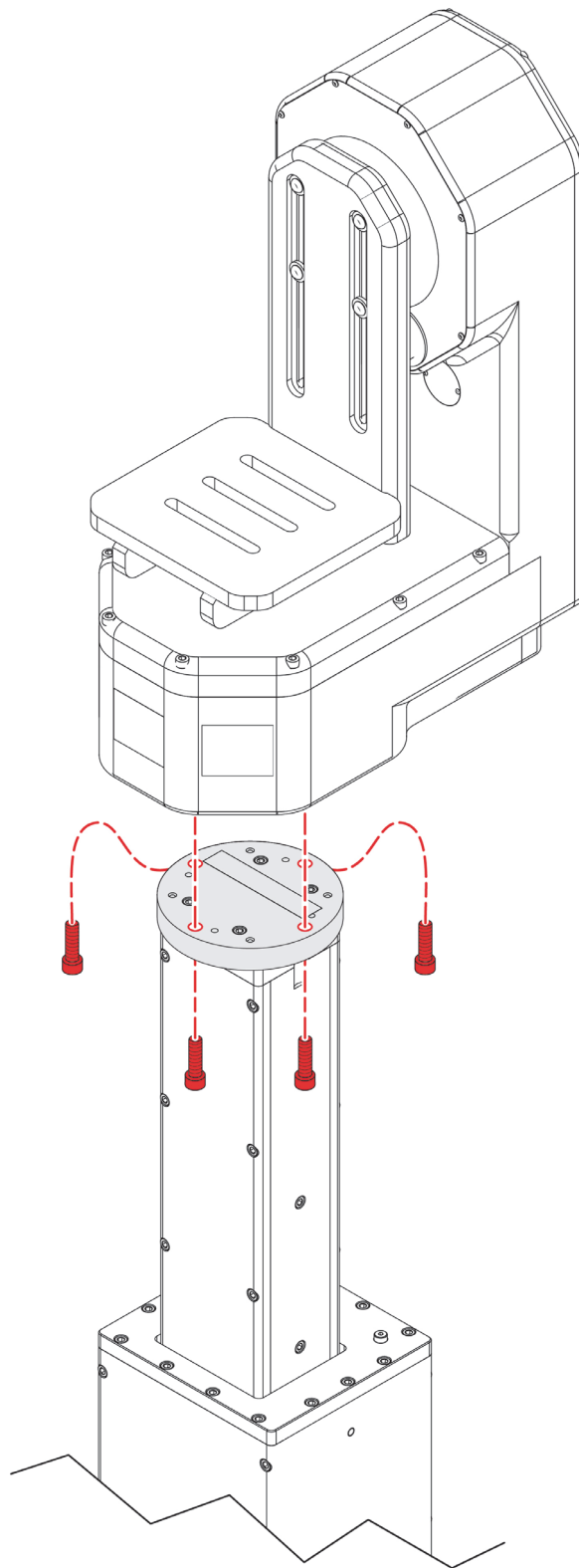

Figure 9 - Removing the 700-Series Head from the Lift Column (4 screws; 5/16" hex key required)

- d. Remove the head and then place it gently on a sturdy surface.

5. Do the following to raise the lift column to the highest position for strut servicing:
 - a. Press and hold the **STRUT** button and then turn the pedestal **ON** (see **Figure 10**).
As the pedestal initializes, the telescopic lift column retracts (lowers) and then extends (rises).

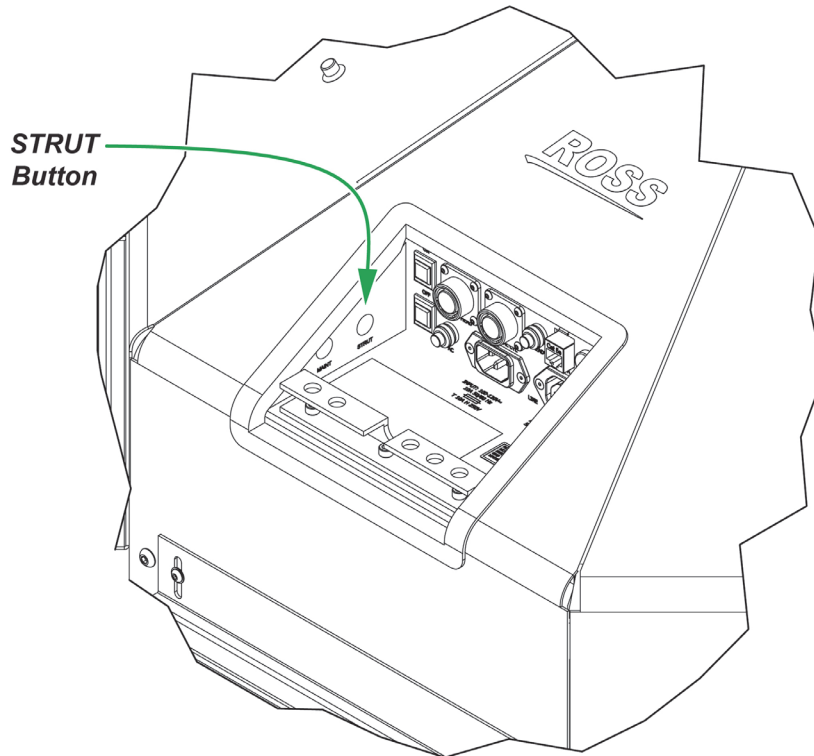

Figure 10 - The STRUT Button on the Connection Panel

- b. Continue to hold the **STRUT** button until the lift column starts to rise, and then release the button.
The lift column rises to the highest position. This reduces the compression force on the struts so they can be removed.

6. At the top of lift column's middle stage, use a 1/8" hex key to remove the two strut top screws. In **Figure 11**, these screws are shown as purple. Retain the screws for installing the new struts.

Tip: Each of the strut top screws is threaded into the top of one of the struts.

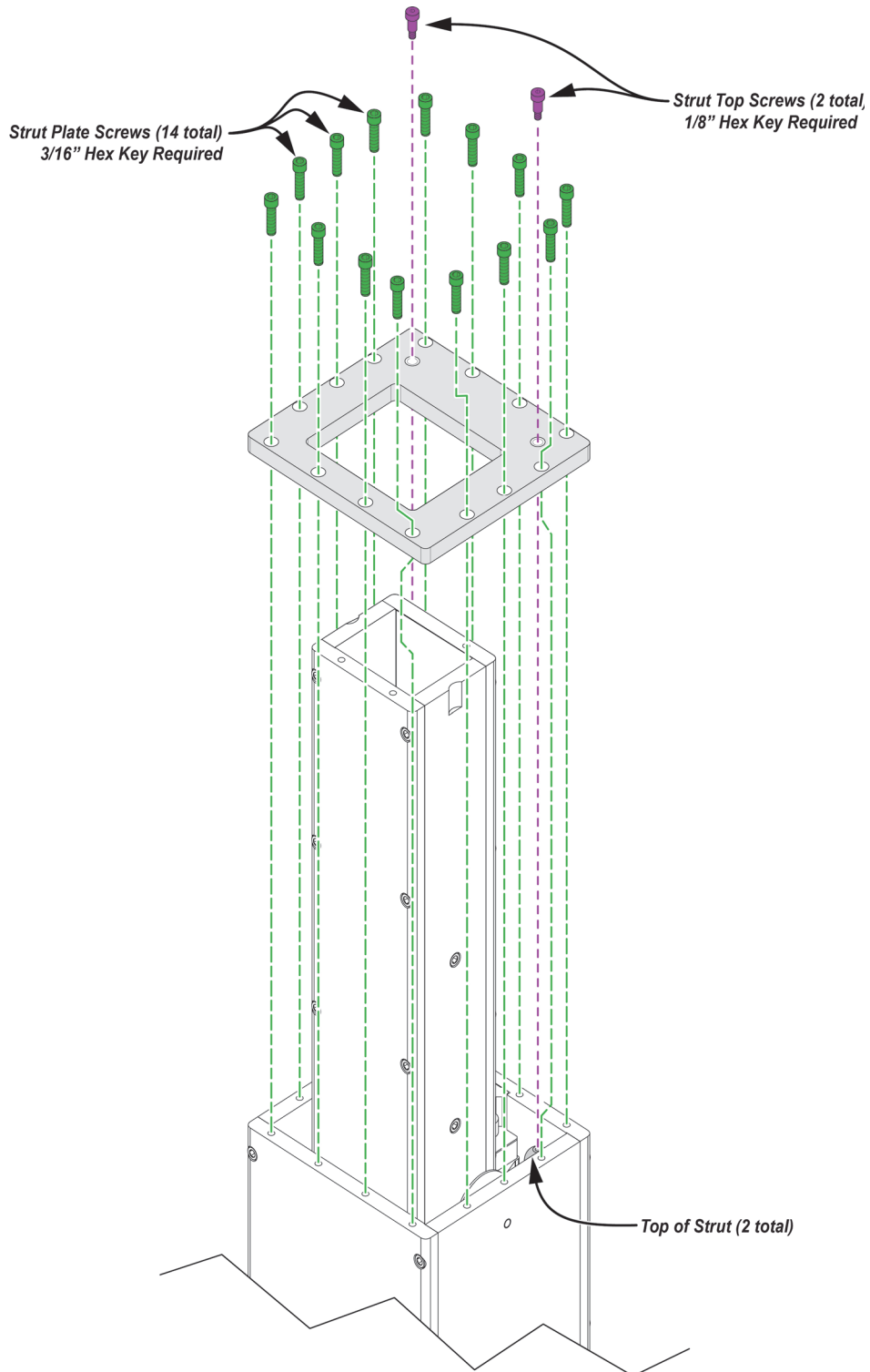

Figure 11 - Strut Top Screws (2 pcs) and Strut Plate Screws (14 pcs) (Top plate on lift column omitted for clarity)

7. Use a 3/16 hex key to remove the 14 screws that fasten the strut plate to the lift column. In **Figure 11**, these screws are shown as green. Retain the screws for re-installation later.
8. While another person lifts the strut plate as high as possible and holds it there, lift the two struts out of the lift column.
9. Examine the new struts, noting that one end is narrower than the other.
10. Insert each of the new struts into the lift column, narrow end first, as shown in **Figure 12**.

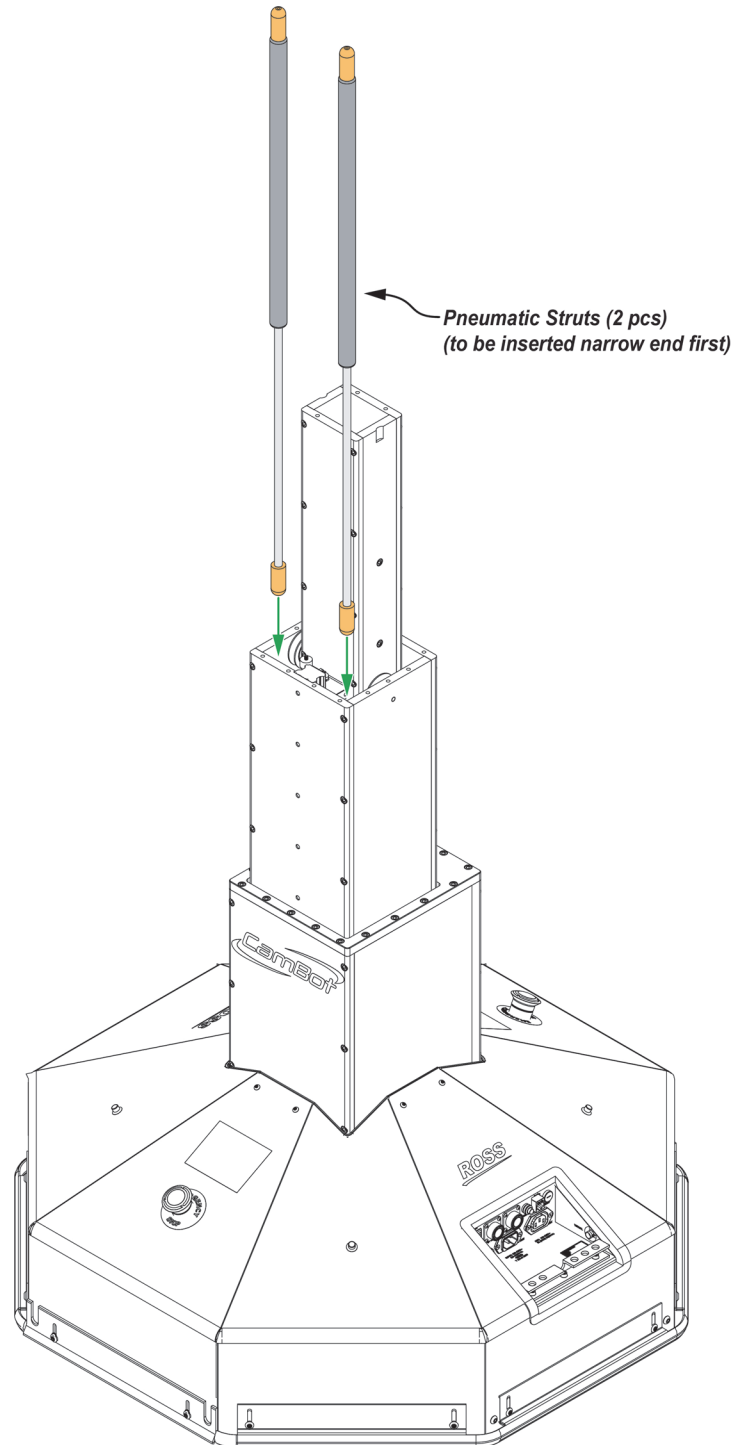

Figure 12 - Inserting Pneumatic Struts, Narrow End First (Top plate on lift column omitted for clarity)

11. Carefully seat the struts into the semi-spherical strut-locating indentations in the base plate of the pedestal. Move each strut side-to-side until you feel it settle into its indentation.

Figure 13 is a top-down view of the three-stage pedestal. The indentations are shown as red circles.

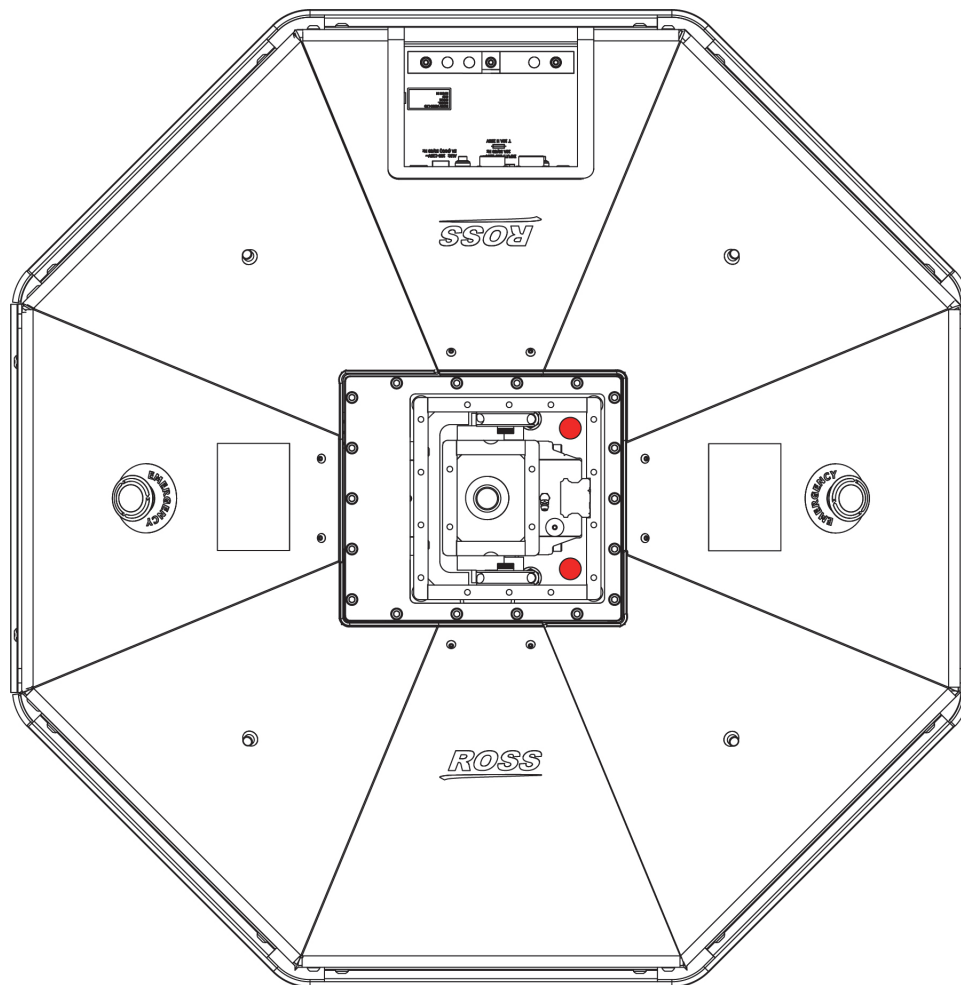

Figure 13 - Top-down View of a CamBot XY Pedestal with three-stage lift, showing Strut-Locating Indentations in Red (Top plate on lift column omitted for clarity)

12. Lower the strut plate into position, ensuring that the spherical ends of the struts align with the matching indentations on the underside of the plate.
13. Use a 1/8" hex key to install and tighten the strut top screws, threading them into the tops of the struts (see **Figure 11** on page 4–40).

IMPORTANT: Be careful not to dislodge the bottoms of the struts from the strut-locating indentations.

14. Use a 3/16" hex key to reinstall the 14 strut plate screws.

IMPORTANT: Tighten the screws in stages. Tighten each screw a few turns, and then repeat. Ensure the strut plate remains horizontal as you tighten the screws, to prevent the struts from dislodging from the strut-locating indentations. See **Figure 14** and **Figure 15**.

As you tighten the screws, the strut plate compresses the struts slightly. Ensure that all screws are equally tight.

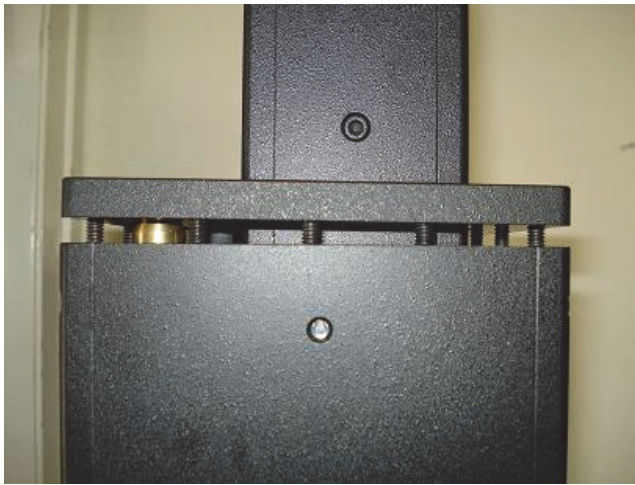

Figure 14 - CORRECT Alignment of the Strut Plate

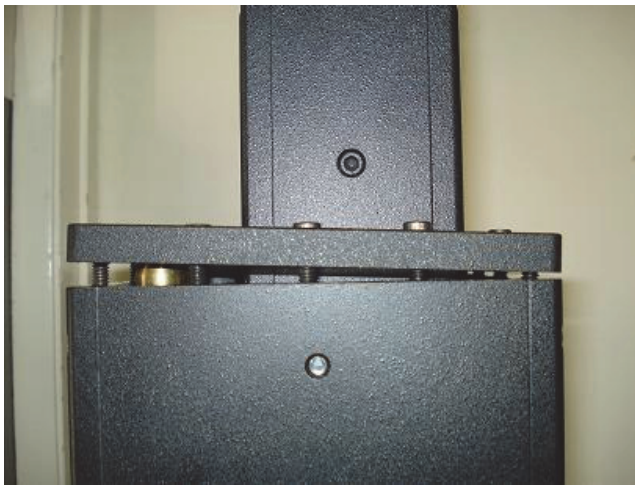

Figure 15 - INCORRECT Alignment of the Strut Plate

15. Turn the pedestal **OFF**, wait a few seconds, and then turn it **ON**.

The pedestal initializes, lowering and then raising the lift column.

16. Lower the pedestal, and then turn it **OFF**.
17. Install the payload and reattach cables as required.

Dress the cables properly, so that strain on connectors is eliminated as much as possible, and that the cables have adequate slack to allow for the full range of robotic motion.

CamBot XY Pedestal with Two-Stage Lift — Replacing the Strut

This section describes how to replace the pneumatic strut in a CamBot XY pedestal that has a two-stage lift. This procedure applies to pedestal model 600XY-S2 only.

The two-stage lift column requires one strut. The strut must be suitable for the payload. For more information, see “**Selecting Appropriate Struts**” on page 4-36.

The strut is installed internally. It extends from an indentation in the base plate of the pedestal to an indentation in the top plate of the lift column. The steps in this section refer to this plate as the “strut plate”.

Replacing the strut requires two people, and takes approximately 45 minutes.

Tools required include 3/16” and 5/16” hex keys (also known as hexagonal wrenches, or as Allen keys).

To replace the pneumatic strut:

1. Move the pedestal to an open area so you have easy access to all sides.
2. Lower the lift column all the way to allow easy access to the payload.
3. Remove the payload, and then turn the pedestal **OFF**.
4. Do the following to remove the head:
 - a. Disconnect all cables from the head.
 - b. Have someone hold the head steady to prevent it from falling.
 - c. Use a 5/16" hex key to remove the four screws that fasten the head to the lift column.

Tip: In **Figure 16**, the screws and the holes in the strut plate at the top of the lift column are shown as red.

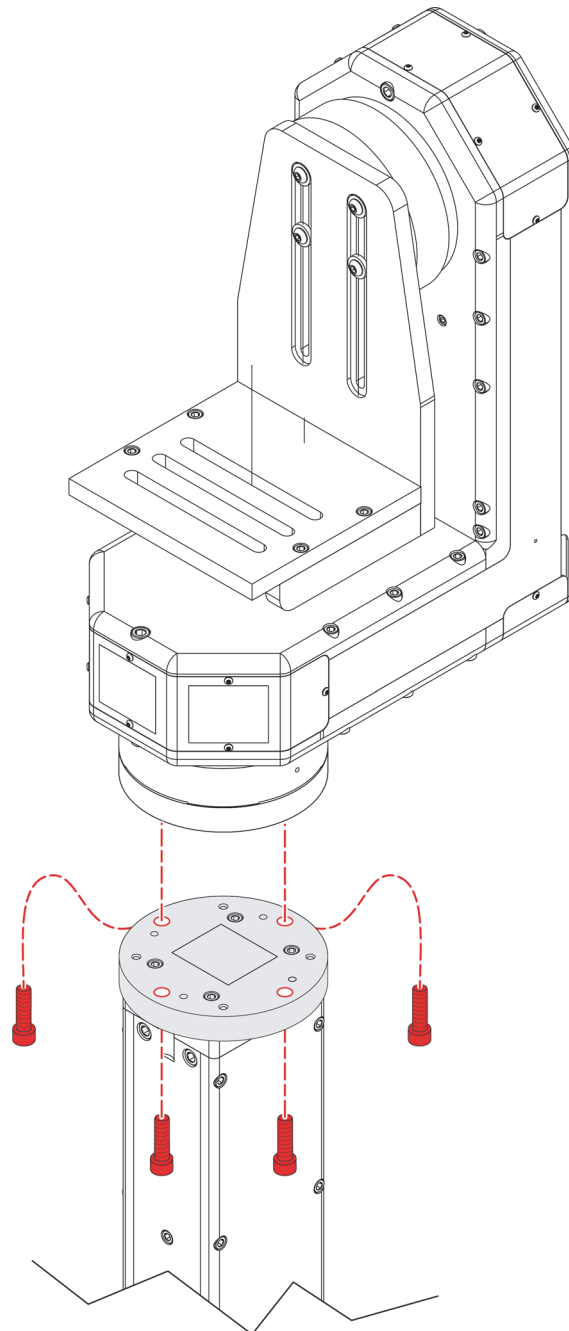

Figure 16 - Removing the 600-Series Head from the Lift Column (4 screws; 5/16" hex key required)

- d. Remove the head and then place it gently on a sturdy surface.
5. Do the following to raise the lift column to the highest position for strut servicing:
 - a. Press and hold the **STRUT** button and then turn the pedestal **ON** (see **Figure 17**).
As the pedestal initializes, the telescopic lift column retracts (lowers) and then extends (rises).

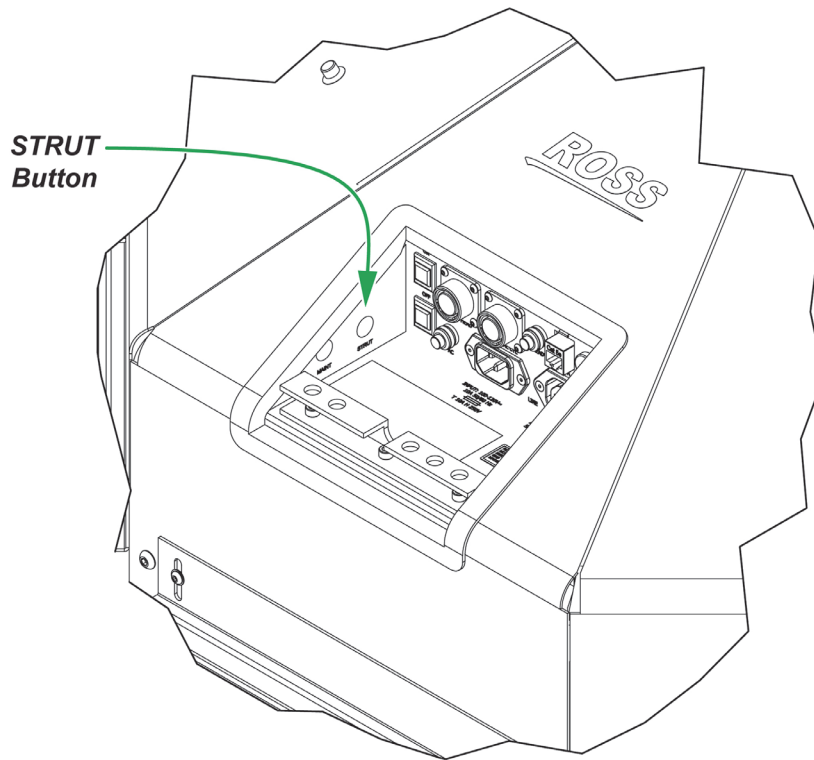

Figure 17 - The STRUT Button on the Connection Panel

- b. Continue to hold the **STRUT** button until the lift column starts to rise, and then release the button.

The lift column rises to the highest position. This reduces the compression force on the strut so it can be removed.

- Use a 3/16" hex key to remove the four screws that fasten the strut plate to the top of the lift column. In **Figure 18**), these screws are shown as green. Retain the screws for re-installation later.

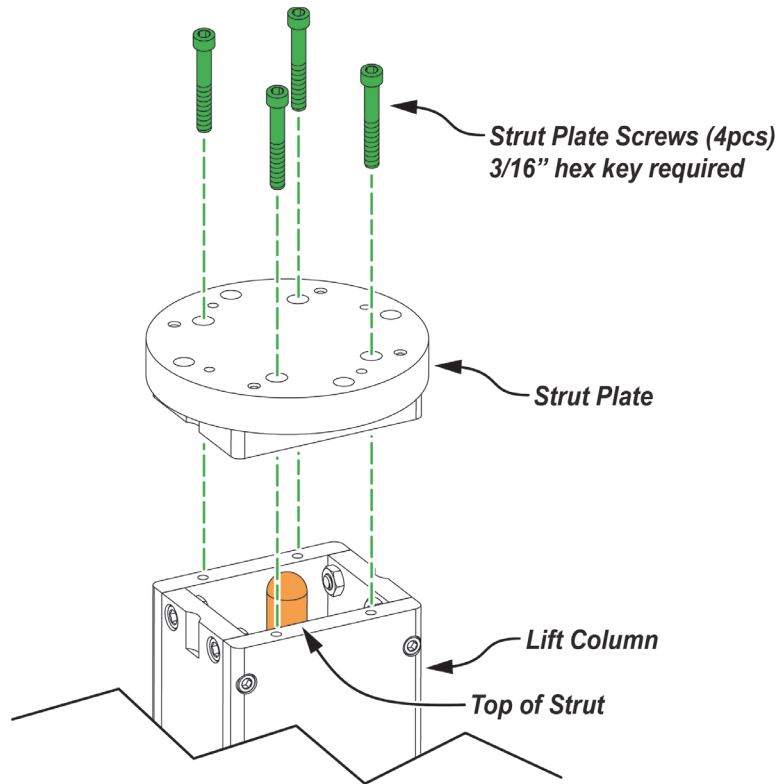

Figure 18 - Removing the Strut Plate Screws (4 pcs)

- Lift the strut out of the lift column.
- Examine the new strut, noting that one end is narrower than the other.

9. Insert the new strut into the lift column, narrow end first, as shown in **Figure 19**.

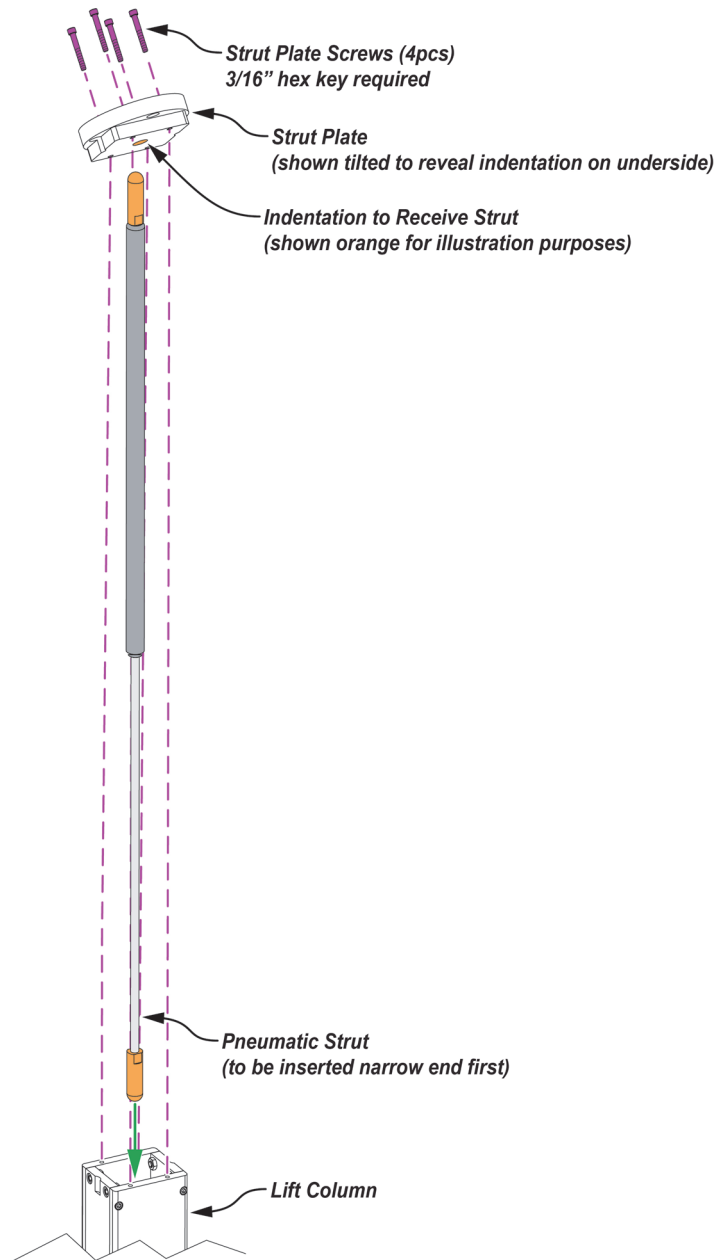

Figure 19 - Inserting the Pneumatic Strut (narrow end first)

10. Carefully seat the strut into the semi-spherical strut-locating indentation in the base plate of the pedestal. Move the strut side-to-side until you feel it settle into its indentation.

Tip: **Figure 20** is a top-down view of the two-stage pedestal. The indentation is shown as a red circle.

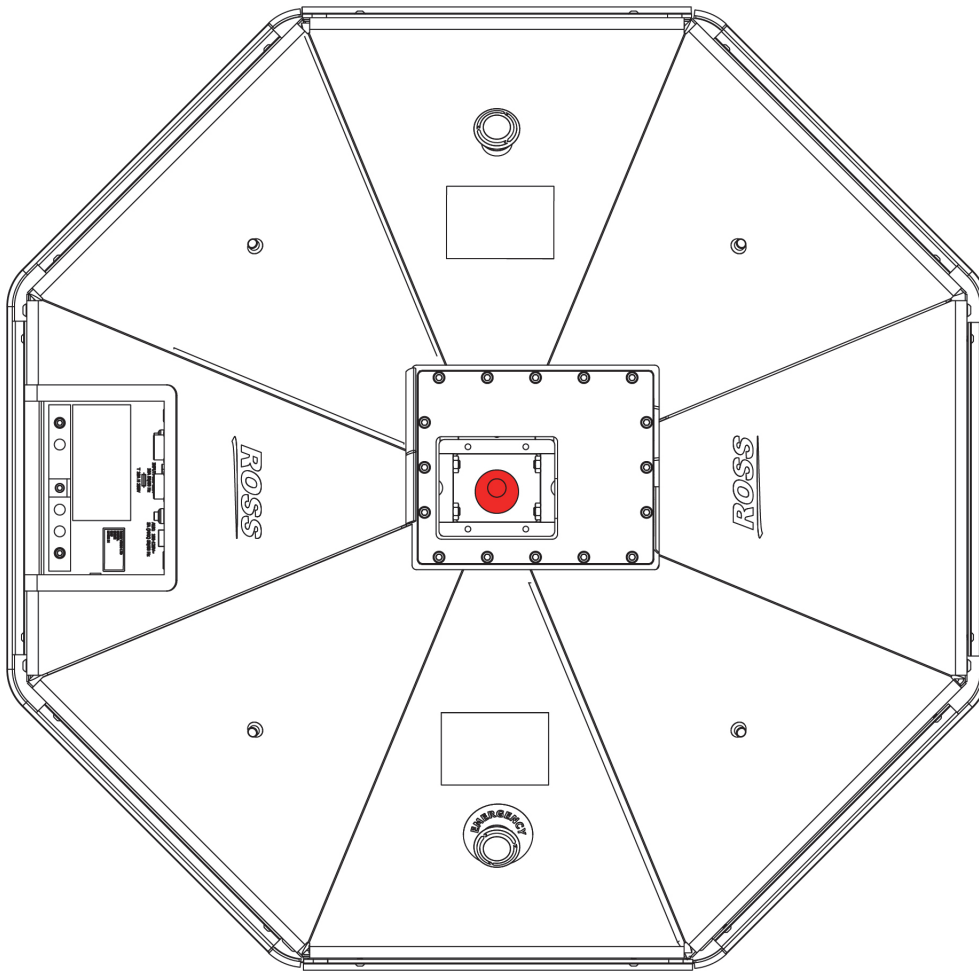

Figure 20 - Top-down View of a CamBot XY Pedestal with two-stage lift, showing Strut-Locating Indentation in Red

11. Lower the strut plate into position, ensuring that the spherical end of the strut aligns with the matching indentation on the underside of the plate.

IMPORTANT: Be careful not to dislodge the bottom of the strut from the strut-locating indentation.

12. Use a 3/16" hex key to reinstall the four strut plate screws.

IMPORTANT: Be careful not to dislodge the top or bottom for the strut from the strut-locating indentations.

IMPORTANT: Tighten the screws in stages. Tighten each screw a few turns, and then repeat. Ensure the strut plate remains horizontal as you tighten the screws, to prevent the strut from dislodging from the strut-locating indentation.

As you tighten the screws, the strut plate compresses the struts slightly. Ensure that all screws are equally tight.

13. Turn the pedestal **OFF**, wait a few seconds, and then turn it **ON**.

The pedestal initializes, lowering and then raising the lift column.

14. Lower the pedestal, and then turn it **OFF**.

15. Install the payload and reattach cables as required.

Dress the cables properly, so that strain on connectors is eliminated as much as possible, and that the cables have adequate slack to allow for the full range of robotic motion.

Technical Specifications

This section contains technical specifications for CamBot XY Pedestals and compatible CamBot heads. It includes the following sub-sections:

- “Specifications Table” on page 5–49
- “Physical Dimensions” on page 5–51

Specifications Table

The following tables lists technical specifications for CamBot XY Pedestals and compatible CamBot heads.

Property	700XY	600XY-S3	600XY-S2
General Properties			
Lift Column Type	Three-stage	Three-stage	Two-stage
Robotic Head	CamBot 700-Series	CamBot 600-Series	CamBot 600-Series
Repeatability	Pan/Tilt: <0.02 degrees XY (floor): 1mm at 10m	Pan/Tilt: <0.02 degrees XY (floor): 1mm at 10m	Pan/Tilt: <0.02 degrees XY (floor): 1mm at 10m
Payload Capacity	min 40 lbs (18 kg) max 200 lbs (90 kg)	min 20 lbs (9 kg) max 125 lbs (57 kg)	min 0 lbs (0 kg) max 125 lbs (57 kg)
Maximum Speed			
Pan (degrees/sec)	90 degrees per second	90 degrees per second	90 degrees per second
Tilt (degrees/sec)	90 degrees per second	90 degrees per second	90 degrees per second
Lift	6" (15cm) per second	6" (15cm) per second	5" (127 mm) per second
XY (floor travel)	12" (30cm) per second	12" (30cm) per second	12" (30cm) per second
Height			
Pedestal Without Head	min 24.9" (632 mm) max 54.1" (1373 mm)	min 24.9" (632 mm) max 54.1" (1373 mm)	min 30.1" (765 mm) max 49.1" (1248 mm)
Pedestal With Head (without camera cradle)	min 45.3" (1149 mm) max 74.5" (1890 mm)	min 42.6" (1081 mm) max 71.8" (1822 mm)	min 47.8" (1214 mm) max 66.8" (1697 mm)
Head Only (without camera cradle)	20.4" (517 mm)	17.7" (449 mm)	17.7" (449 mm)
Distance from Floor to Tilt Axis	min 40.7" (1035 mm) max 70.6" (1794 mm)	min 40.0" (1015 mm) max 69.1" (1756 mm)	min 45.2" (1148 mm) max 64.2" (1631 mm)
Distance from Floor to Cradle (the surface to which payload is mounted) Payload must be balanced around the tilt axis. Balancing the load determines the cradle position in relation to the tilt axis.			
With Lift Column at Min Height	min 33.4" (850 mm) max 37.3" (948 mm)	min 33.4" (848 mm) max 37.0" (940 mm)	min 38.6" (981 mm) max 42.3" (1074 mm)
With Lift Column at Max Height	min 62.6" (1591 mm) max 66.5" (1689 mm)	min 62.6" (1589 mm) max 66.2" (1682 mm)	min 57.6" (1464 mm) max 61.3" (1556 mm)
Length and Width	length 33.9" (862 mm) width 33.2" (845 mm)	length 33.9" (862 mm) width 33.2" (845 mm)	length 33.9" (862 mm) width 33.2" (845 mm)
Weight	375 lbs (170 kg)	357 lbs (162 kg)	341 lbs 155 kg)

Property	700XY	600XY-S3	600XY-S2
Range of Motion			
Pan Axis	+/- 358 degrees	+/- 358 degrees	+/- 178 degrees
Tilt Axis	+/- 90 degrees	+/- 90 degrees	+/- 90 degrees
Lift Axis (vertical stroke)	30" (76.2 cm)	30" (76.2 cm)	20"(50.8 cm)
Power Consumption			
Total for pedestal, head, and accessories (prompter, etc)	1200 Watts (maximum)	1200 Watts (maximum)	1050 Watts (maximum)
Pedestal and head only	600 Watts (maximum)	600 Watts (maximum)	450 Watts (maximum)
Additional power available through auxiliary power socket, for prompter and other accessories.	600 Watts (maximum)	600 Watts (maximum)	600 Watts (maximum)

Physical Dimensions

This section contains dimensioned drawings of all three CamBot XY Pedestal models:

- “CamBot 600XY-S2 Pedestal — Physical Dimensions” on page 5-51
- “CamBot 600XY-S3 Pedestal — Physical Dimensions” on page 5-53
- “CamBot 700XY Pedestal — Physical Dimensions” on page 5-55

CamBot 600XY-S2 Pedestal — Physical Dimensions

Figure 1 shows side views of the CamBot 600XY-S2 Pedestal with the two-stage lift column lowered (left), and raised (right). The camera cradle is shown in both its lowest position and its highest (dotted lines). Measurements are shown in inches, followed by [millimeters].

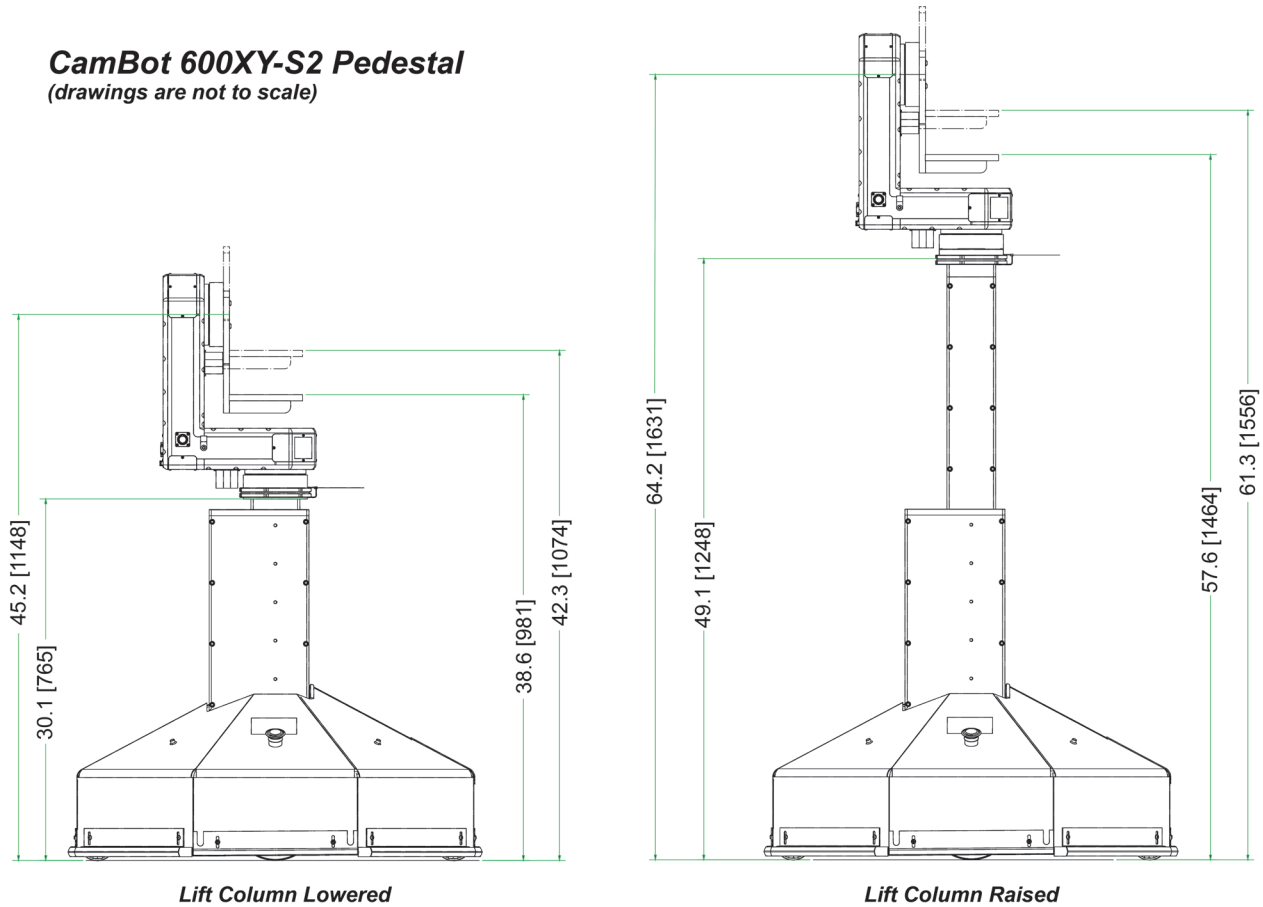

Figure 1 - CamBot 600XY-S2 Pedestal (side views)

Figure 2 shows the top view of the CamBot 600XY-S2 Pedestal. Measurements are shown in inches, followed by [millimeters].

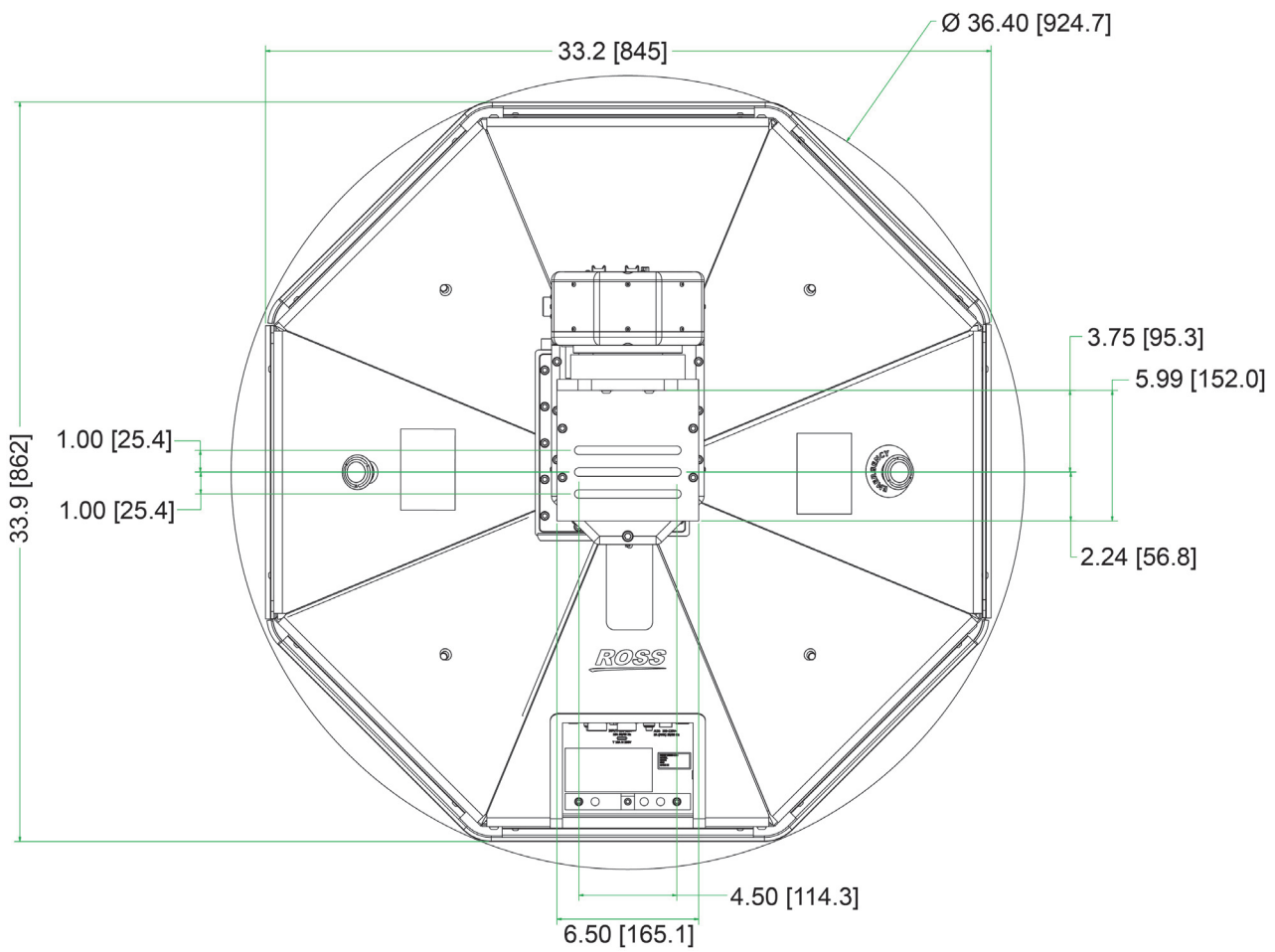

Figure 2 - CamBot 600XY-S2 Pedestal (top view)

CamBot 600XY-S3 Pedestal — Physical Dimensions

Figure 3 shows side views of the CamBot 600XY-S3 Pedestal with the three-stage lift column lowered (left), and raised (right). The camera cradle is shown in both its lowest position and its highest (dotted lines). Measurements are shown in inches, followed by [millimeters].

CamBot 600XY-S3 Pedestal (drawings are not to scale)

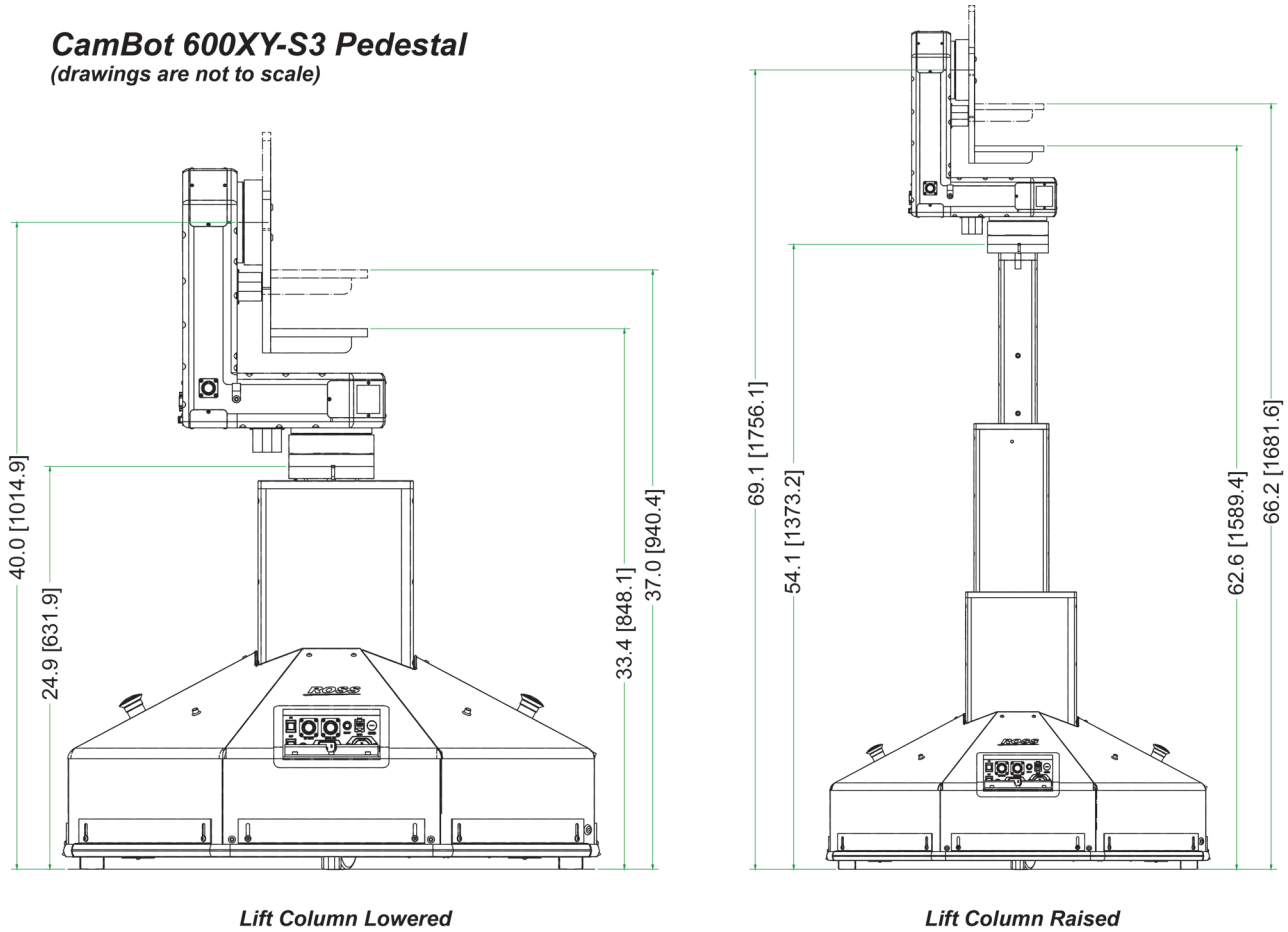

Figure 3 - CamBot 600XY-S3 Pedestal (side views)

Figure 2 shows the top view of the CamBot 600XY-S3 Pedestal. Measurements are shown in inches, followed by [millimeters].

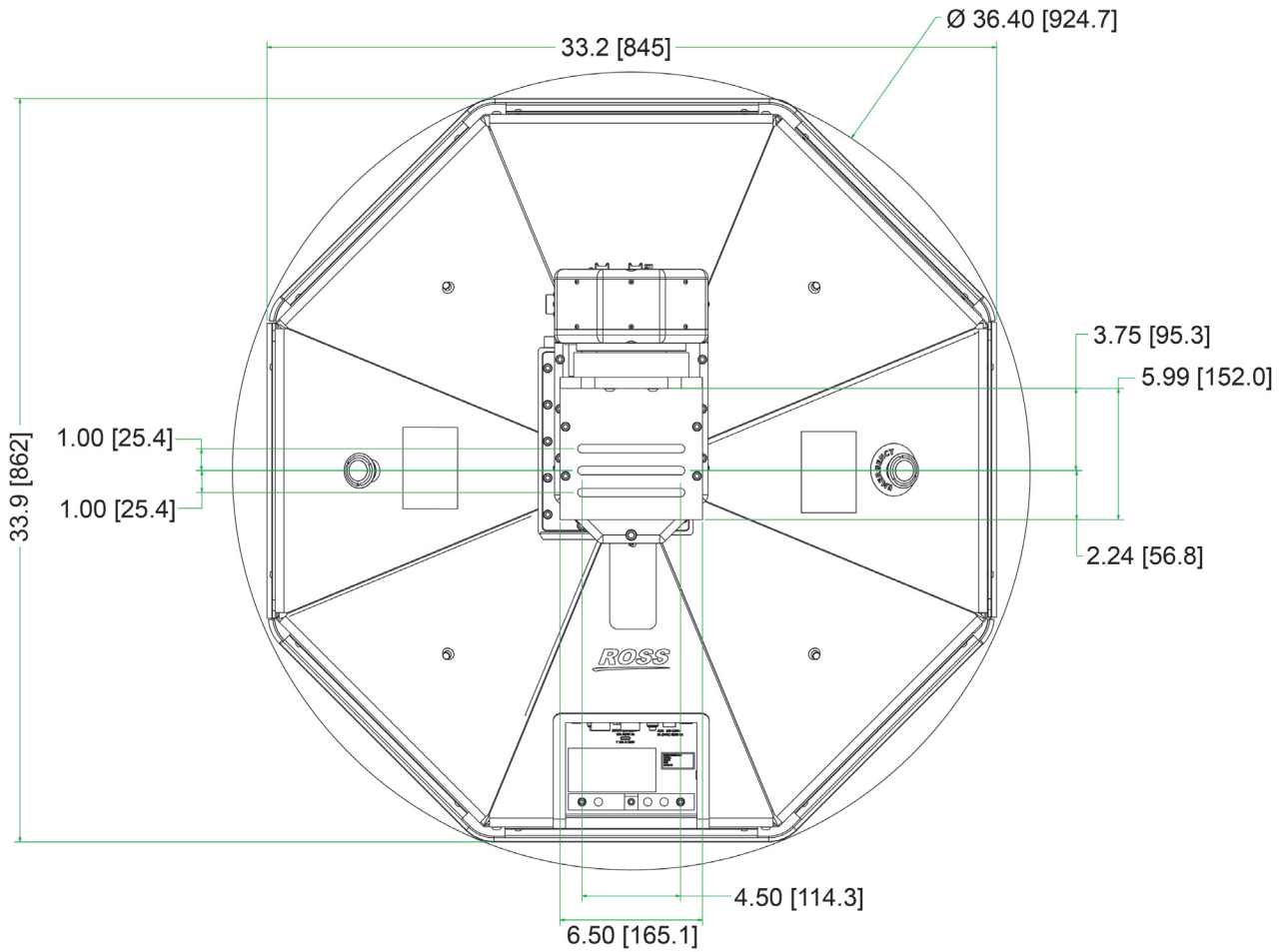

Figure 4 - CamBot 600XY-S3 Pedestal (top view)

CamBot 700XY Pedestal — Physical Dimensions

Figure 5 shows side views of the CamBot 700XY Pedestal with the three-stage lift column lowered (left), and raised (right). The camera cradle is shown in both its lowest position and its highest (dotted lines). Measurements are shown in inches, followed by [millimeters].

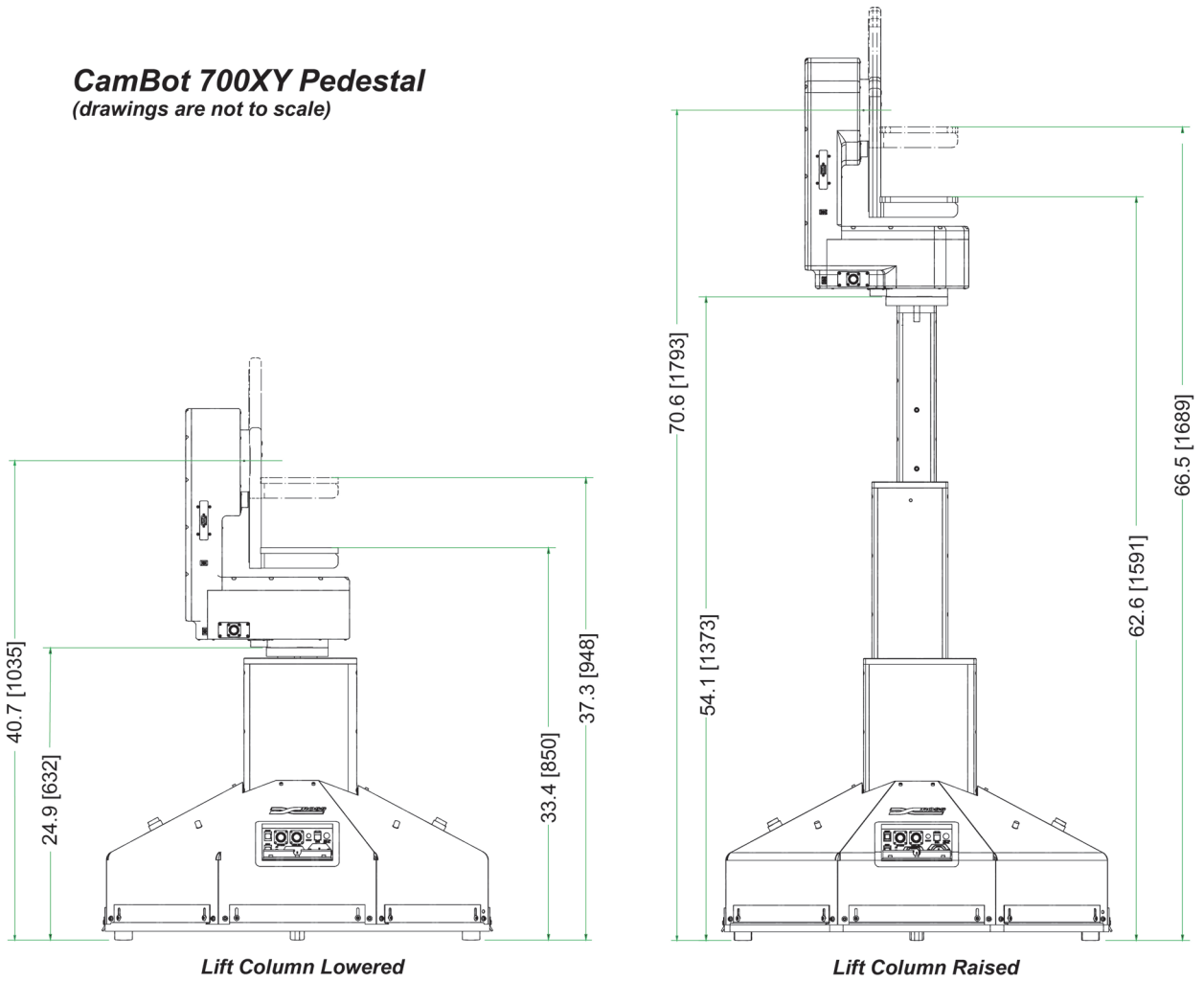

Figure 5 - CamBot 700XY Pedestal (side views)

Figure 2 shows the top view of the CamBot 700XY Pedestal. Measurements are shown in inches, followed by [millimeters].

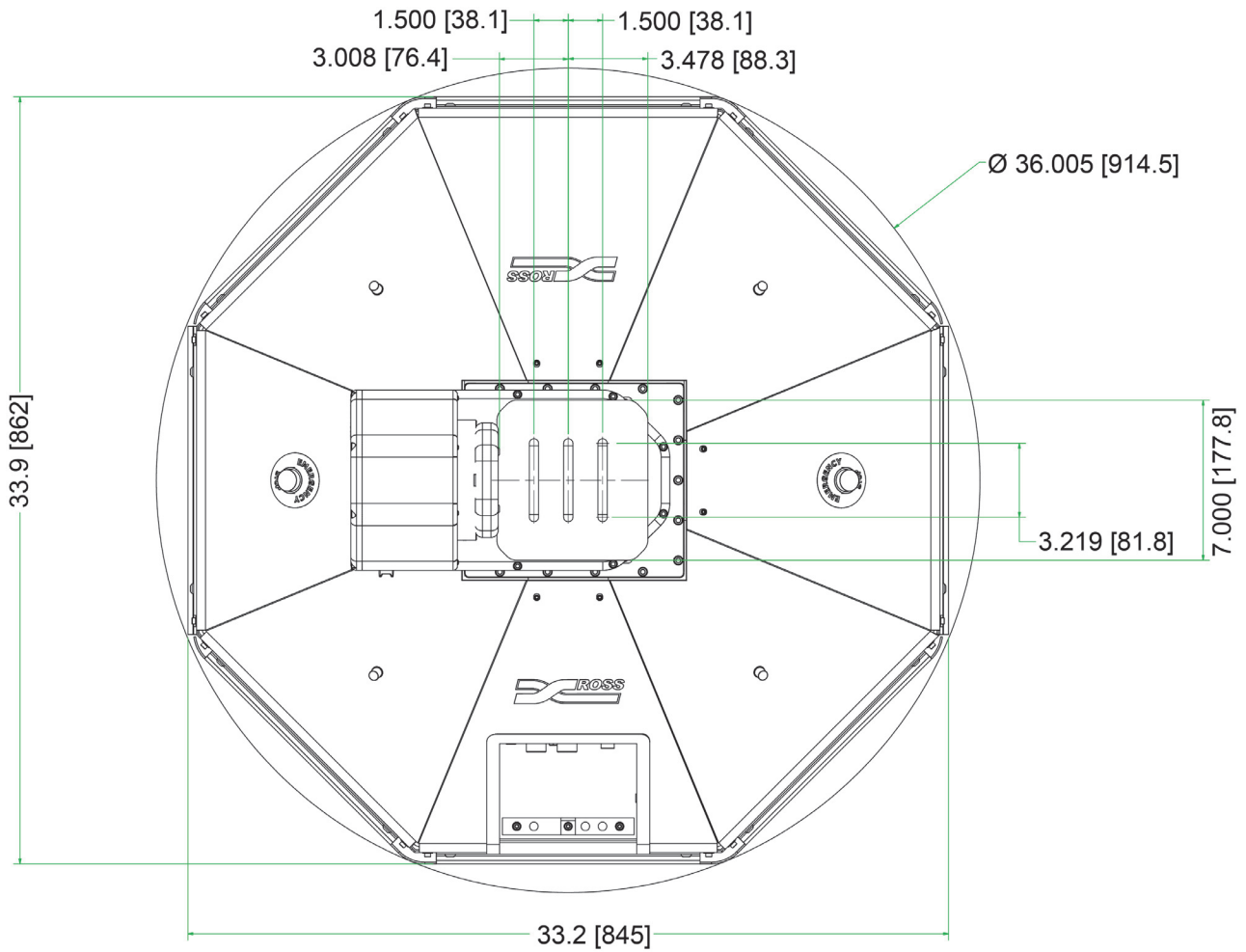

Figure 6 - CamBot 700XY Pedestal (top view)