



## BlackBird C2 Pedestal

### Technical Manual



# Thank You for Choosing Ross

You've made a great choice. We expect you will be very happy with your purchase of Ross Technology.

Our mission is to:

1. Provide a Superior Customer Experience
  - offer the best product quality and support
2. Make Cool Practical Technology
  - develop great products that customers love

Ross has become well known for the Ross Video Code of Ethics. It guides our interactions and empowers our employees. I hope you enjoy reading it below.

If anything at all with your Ross experience does not live up to your expectations be sure to reach out to us at [solutions@rossvideo.com](mailto:solutions@rossvideo.com).



David Ross  
CEO, Ross Video  
[dross@rossvideo.com](mailto:dross@rossvideo.com)

## Ross Video Code of Ethics

Any company is the sum total of the people that make things happen. At Ross, our employees are a special group. Our employees truly care about doing a great job and delivering a high quality customer experience every day. This code of ethics hangs on the wall of all Ross Video locations to guide our behavior:

1. We will always act in our customers' best interest.
2. We will do our best to understand our customers' requirements.
3. We will not ship crap.
4. We will be great to work with.
5. We will do something extra for our customers, as an apology, when something big goes wrong and it's our fault.
6. We will keep our promises.
7. We will treat the competition with respect.
8. We will cooperate with and help other friendly companies.
9. We will go above and beyond in times of crisis. *If there's no one to authorize the required action in times of company or customer crisis - do what you know in your heart is right. (You may rent helicopters if necessary.)*

# Technical Manual for the BlackBird C2 Pedestal

- Ross Part Number: 5100DR-095-01
- Publication Date: July 11, 2022. Printed in Canada.

## Copyright

©2022 Ross Video Limited, Ross®, and any related marks are trademarks or registered trademarks of Ross Video Limited. All other trademarks are the property of their respective companies. PATENTS ISSUED and PENDING. All rights reserved. No part of this publication may be reproduced, stored in a retrieval system, or transmitted in any form or by any means, mechanical, photocopying, recording or otherwise, without the prior written permission of Ross Video. While every precaution has been taken in the preparation of this document, Ross Video assumes no responsibility for errors or omissions. Neither is any liability assumed for damages resulting from the use of the information contained herein.

## Patents

Ross Video products are protected by patent numbers US 7,034,886; US 7,508,455; US 7,602,446; US 7,802,802 B2; US 7,834,886; US 7,914,332; US 8,307,284; US 8,407,374 B2; US 8,499,019 B2; US 8,519,949 B2; US 8,743,292 B2; GB 2,419,119 B; GB 2,447,380 B. Other patents pending.

## Company Address and Contact Information



**Ross Video Limited**  
8 John Street  
Iroquois, Ontario  
Canada, K0E 1K0

**Ross Video Incorporated**  
P.O. Box 880  
Ogdensburg, New York  
USA 13669-0880

General Business Office: (+1) 613 • 652 • 4886

Fax: (+1) 613 • 652 • 4425

Toll Free Technical Support: 1-844-652-0645 (North America)

+800 1005 0100 (International)

Technical Support: (+1) 613 • 652 • 4886

E-mail for Technical Support: [techsupport@rossvideo.com](mailto:techsupport@rossvideo.com)

ROSS VIDEO | HELP CENTER: <https://support.rossvideo.com/hc/en-us>

E-mail for General Information: [solutions@rossvideo.com](mailto:solutions@rossvideo.com)

Ross Video Website: <http://www.rossvideo.com>

# Contents

<b>Welcome</b>	<b>5</b>
Text Formatting Conventions .....	5
Contacting Technical Support .....	6
Important Notices .....	6
Important Safety Notices .....	7
<b>Product Overview</b>	<b>9</b>
BlackBird Pedestal Base .....	10
BlackBird C2 Lift .....	12
CamBot 600 Head .....	13
Steering Ring .....	14
Local Control Box and Pan Bars .....	15
Site Requirements .....	15
<b>Control Systems</b>	<b>17</b>
SmartShell Control Application .....	17
The Joystick Panel .....	18
Local Control .....	19
<b>Maintenance</b>	<b>23</b>
General Inspection and Cleaning .....	23
Cleaning the Cable Guards and Wheels .....	24
Balancing the Payload .....	25
Removing the Head .....	27
Replacing the Pneumatic Strut .....	28
<b>Technical Specifications</b>	<b>34</b>
Specifications Table .....	34
Physical Dimensions .....	35

# Welcome

Welcome to the ***BlackBird C2 Pedestal Technical Manual***.

This manual provides a general overview of the system, technical specifications, basic maintenance procedures, and safety information.

For information about operating the system, see the ***SmartShell User Guide (5100DR-002-xx)***.

**NOTE:** The BlackBird C2 pedestal is one of three models in the Ross family of BlackBird PTL (Pan/Tilt/Lift) pedestals. For information about the other two models, **BlackBird S2** and **BlackBird SE**, please consult the Ross Video web site.

## Text Formatting Conventions

Special text formats are used in this Technical Manual to identify parts of the user interface, text that a user must enter, or a sequence of menus and sub-menus that must be followed to reach a particular command.

Text Format	Meaning
<b>Bold text</b>	Bold text is used to identify a user interface element such as a dialog box, menu item, or button. For example: In the <b>Presets</b> panel, tap <b>Add</b> .
Courier text	Courier text is used to identify text that a user must type. For example: In the address bar, type <code>localhost</code> and press <b>Enter</b> .
<b>Italic text</b>	Italic text is used to identify the titles of referenced guides, manuals, or documents. For example: For more information, refer to the <b><i>SmartShell Computer Quick Start Guide</i></b> .
>	Menu arrows are used in procedures to identify a sequence of menu items that you must follow. For example, if a step reads “ <b>Display &gt; Widgets</b> ,” you would tap the <b>Display</b> menu and then tap <b>Widgets</b> .

## Contacting Technical Support

At Ross Video, we take pride in the quality of our products, but if problems occur, help is as close as the nearest telephone.

Our 24-hour Hot Line service ensures you have access to technical expertise around the clock. After-sales service and technical support is provided directly by Ross Video personnel.

During business hours (Eastern time), technical support personnel are available by telephone any time. Emergency after hours calls are answered by an answering service (live person) who will patch your call to the on-call support specialist. In the event that the on-call person is assisting another customer, the answering service will contact the back-up support specialist.

Our team of highly trained staff is available to react to any problem and to do whatever is necessary to ensure customer satisfaction.

- **Toll Free Technical Support 24/7:** 1-844-652-0645 (North America), or +800 1005 0100 (International)
- **Technical Support:** (+1) 613-652-4886
- **E-mail for Technical Support:** [techsupport@rossvideo.com](mailto:techsupport@rossvideo.com)
- **ROSS VIDEO | HELP CENTER:** <https://support.rossvideo.com/hc/en-us>
- **E-mail for General Information:** [solutions@rossvideo.com](mailto:solutions@rossvideo.com)
- **Ross Video Website:** <http://www.rossvideo.com>

## Important Notices

This section contains important notices.

### Korean Class A Notice

The following is the Korean Class A Broadcasting and Telecommunication Products for Business Purpose Statement.










이 기기는 업무용(A급) 전자파적합기기로서 판매자 또는 사용자는 이 점을 주의하시기 바라며, 가정외의 지역에서 사용하는 것을 목적으로 합니다.








The preceding statement applies to the following Ross Video components, and may also apply to others:

- **5100AR-131-01** — CamBot 600 PTL-C2 Pedestal
- **5100AR-252-01** — 6-Axis Unified Robotics Control Panel

## Important Safety Notices

The following table contains important safety notices and safety instructions. Before using this product and any associated equipment, read and keep these notices and instructions. Heed all warnings and follow all safety instructions.

	<b>Caution</b>	This equipment must be operated by trained personnel only. This equipment must be operated in a controlled and restricted environment only.
	<b>Warning</b>	The safe operation of this product requires that a protective earth connection be provided. A grounding conductor in the equipment's supply cord provides this protective earth. To reduce the risk of electrical shock to the operator and service personnel, this ground conductor must be connected to an earthed ground. Use only power cords specified for this product and certified for the country of use. Do not defeat safety purpose of the grounding-type plug. A grounding type plug has two blades and a third grounding prong. The third prong is provided for your safety. If the provided plug does not fit in to your outlet, consult an electrician for replacement of the obsolete outlet. Protect power cord from being walked on or pinched, particularly at plugs, convenience receptacles, and points where they exit from the apparatus.
	<b>ESD</b>	<b>ESD Susceptibility</b> — This symbol on the equipment or within the equipment manual indicates that an electrical or electronic device or assembly is susceptible to damage from an ESD event.
	<b>Warning</b>	<b>Hazardous Voltages</b> — This symbol on the equipment or within the equipment manual indicates the presence of uninsulated “dangerous voltage” within the product enclosure that may be of sufficient magnitude to constitute a risk of shock to persons.
	<b>Warning</b>	Indoor Use: “WARNING – TO REDUCE THE RISK OF FIRE OR ELECTRIC SHOCK, DO NOT EXPOSE THIS APPARATUS TO RAIN OR MOISTURE” Do not use this apparatus near water. Do not block any ventilation openings. Install in accordance with manufacturer’s instructions. Do not install near heat sources such as radiators, heat registers, stoves, or other apparatus (including amplifiers) that produce heat. Only use attachments/accessories specified by the manufacturer. Unplug this apparatus during lightning storms or when unused for long periods of time. Clean only with a dry cloth.
	<b>Warning</b>	Refer all servicing to qualified personnel. Servicing is required when the apparatus has been damaged in any way, such as power-supply cord or plug damage, liquid has been spilled or objects have fallen into the apparatus, the apparatus has been exposed to rain or moisture, does not operate normally, or has been dropped.
	<b>Warning</b>	To reduce the risk of fire, replacement fuses must be the same type and rating.
	<b>Warning</b>	This product contains safety critical parts, which if incorrectly replaced may present a risk of fire or electrical shock. Components contained within the product’s power supplies and power supply area are not customer-serviceable and should be returned to the factory for repair.
	<b>Caution</b>	Ensure that proper cable management techniques are used at all times. Bundle and wrap cables neatly, and provide adequate strain relief and slack where necessary. Test your cable installation by moving the robotic units through their entire range of motion and observing the cables, to ensure that they do not become taut, or snag on anything. Avoid running cables along floors in places where they may present a tripping hazard. Clearly mark areas where cables may present a tripping hazard, and keep personnel away from such areas. Inspect cables periodically for damage, and to ensure that proper cable management is maintained.

	<b>Warning</b>	Damaged or improper cables may cause electric shock and/or fire. Ensure that all cables and connectors are of suitable type for their purpose, and that all power cable conductors are of adequate gauge for the voltage and current required. Inspect all cables periodically to check for damage. If a cable becomes damaged, turn off power to the system immediately, and then replace the damaged cable.
	<b>Warning</b>	Serious injuries can result from people tripping over equipment, such as cables. Methods of reducing such risks include, but are not limited to, the following: <ul style="list-style-type: none"> <li>• Erecting signs at studio entrances to remind people about tripping hazards and other studio hazards.</li> <li>• Training personnel about safety procedures and proper cable management techniques.</li> <li>• Showing personnel and guests the locations of cables equipment, and explaining that robotic cameras and cables attached to them may move at any time.</li> <li>• Escorting guests at all times while in the studio.</li> <li>• Ensuring adequate lighting when working in the studio.</li> <li>• Marking safe paths and/or restricted areas, to keep people away from moving robots and potential tripping hazards.</li> </ul>
	<b>Caution</b>	Loose or overtightened bolts may cause equipment damage. When servicing, tighten bolts to specified torque.
	<b>Warning</b>	Moving parts may present a pinching hazard. Keep all personnel away from robots when they are operational. When a robotic head, pedestal, or robotic lift column moves, fingers touching or near the unit or the payload may become pinched. When installing or adjusting the payload, ensure that power to the system is turned off. When operating a robotic pedestal locally, touch only the pan bars and the local control unit (if equipped).
	<b>Warning</b>	When servicing or moving equipment, always observe safe handling practices. Get help to move heavy items. Use safe lifting techniques. Follow all safety rules of your workplace.
	<b>Caution</b>	Loose payloads may slip, causing equipment damage and injury. Periodically check all bolts that fasten the payload, to ensure that they are tightened to specified torque. If the payload is loose or slips, ensure that it is properly balanced and fastened before operating the robot.
	<b>Warning</b>	Imbalanced payloads may cause equipment damage and may present a tipping hazard. Ensure payloads are properly balanced. If you adjust a payload, always rebalance it.

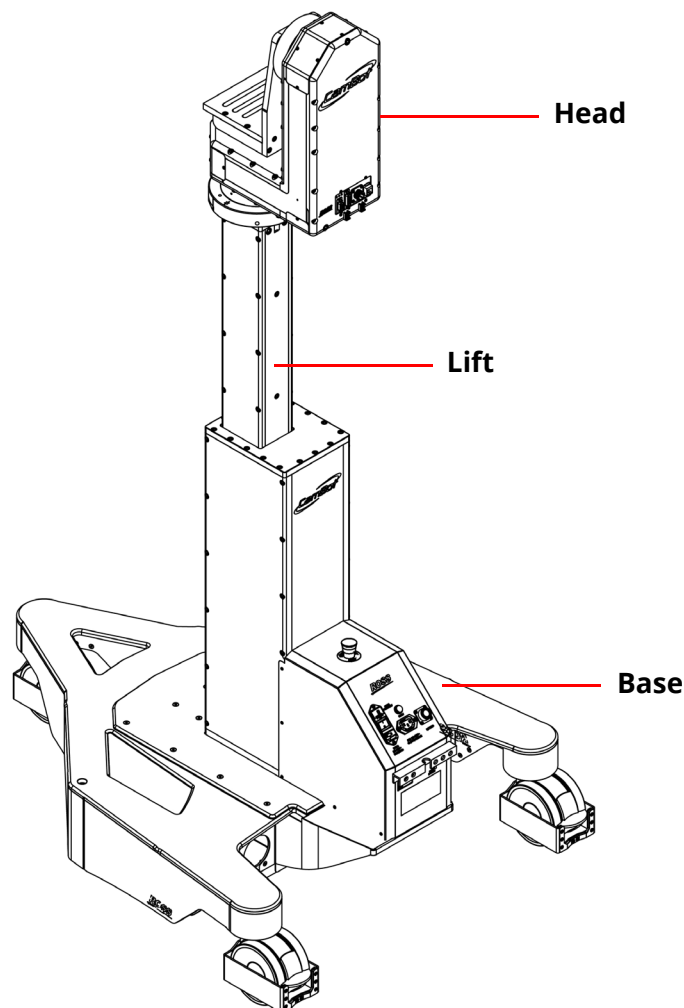
# Product Overview

The BlackBird C2 (**Figure 1**) is a manual pedestal equipped with a two-stage robotic lift system and a CamBot 600 robotic pan and tilt head for cameras. The pedestal can easily be positioned and locked in place, which makes it ideal for studio applications where cameras typically remain in the same floor location for the duration of a show.

The pedestal's robotic lift and pan and tilt head can be controlled by a variety of technologies, including Ross Video's SmartShell control application and joystick panel, production switchers such as Ross Video Acuity, and broadcast automation systems such as Ross Video OverDrive. These systems allow you to remotely operate or automate the adjustment of the camera height, as well as combine smooth vertical movement with pan and tilt to create dynamic on-air moving shots.

The following topics provide more details about the BlackBird C2 pedestal's components:

- ***"BlackBird Pedestal Base" on page 2-10***
- ***"BlackBird C2 Lift" on page 2-12***
- ***"CamBot 600 Head" on page 2-13***
- ***"Steering Ring" on page 2-14***
- ***"Local Control Box and Pan Bars" on page 2-15***
- ***"Site Requirements" on page 2-15***



**Figure 1** - The BlackBird C2 Pedestal

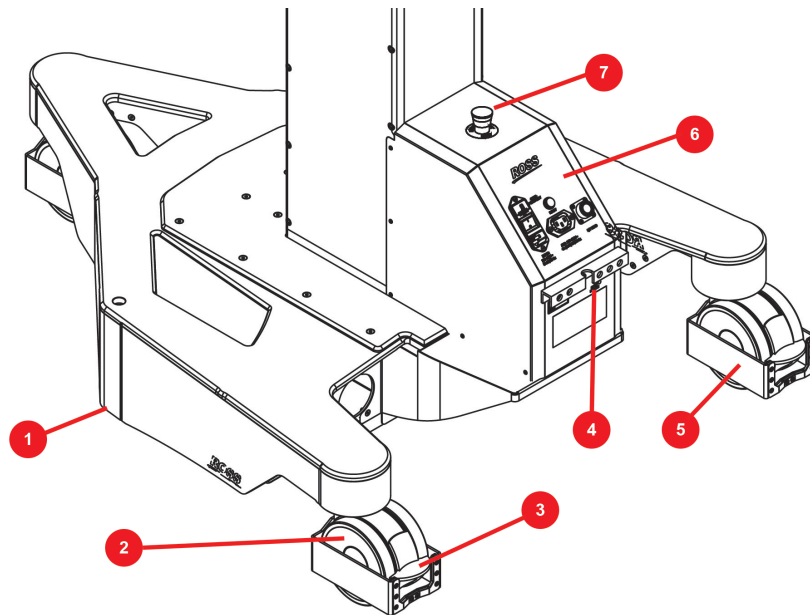
## BlackBird Pedestal Base

The base of the BlackBird pedestal provides a solid, stable foundation for the lift and head, ensuring shake-free pan, tilt, and lift movements.

The three double-caster wheels allow you to easily roll the BlackBird C2 pedestal into position on the studio floor. Once in the desired location, engaging the foot-activated wheel locks ensures that the pedestal remains in position during the show.

Even at a maximum payload and full extension, safety features incorporated into the base's design ensure that the BlackBird C2 pedestal can be moved with virtually no risk of injury or damage to equipment due to tipping. A wide wheel base and two anti-tip feet provide an ultra-stable and safe platform, and the adjustable cable guards on each of the wheels prevents any snags or damage to cables and other objects.

**Figure 2** and the table below it identify and describe the features of the BlackBird C2 pedestal base.



**Figure 2** The BlackBird C2 Pedestal Base

Label	Description
<b>1</b>	<b>Anti-tip Feet</b> Two adjustable anti-tip feet are located under the left and right side of the chassis. If the pedestal begins to tip, these feet make contact with the floor and prevent the pedestal from tipping further.
<b>2</b>	<b>Double Caster Wheels</b> Three sets of double caster wheels provide a wide and stable wheel base and ensure ease of movement when repositioning the pedestal.
<b>3</b>	<b>Wheel Locks</b> Each of the pedestal's wheels features a foot-activated wheel lock, which locks or frees up movement of the wheel. To engage the wheel lock, simply use your foot to press down on the wheel lock lever to prevent the pedestal from moving from its current position. To release the wheel lock, use your foot to lift up the wheel lock lever.

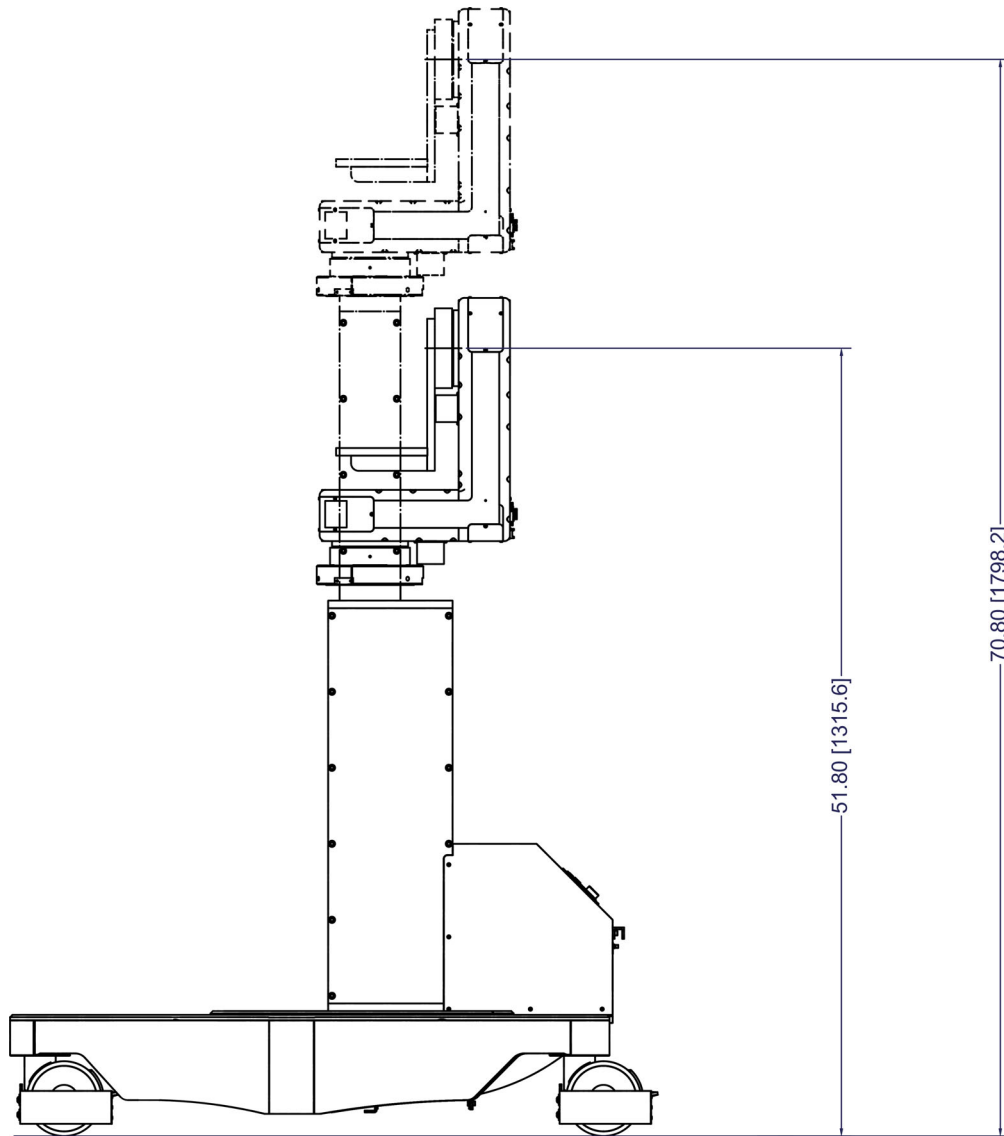
Label	Description
<p>4</p>	<p><b>STRUT REPLACE Button</b></p> <p>When installing/removing the lift's pneumatic strut, this button moves the lift into a position that removes the tension from the strut.</p> <p>To raise the lift column to the highest position for strut removal and installation, turn the pedestal <b>OFF</b>. Press and hold the <b>STRUT REPLACE</b> button and then turn the pedestal <b>ON</b>. The pedestal initializes, which may involve the lift lowering and/or raising to its home position. Continue to hold the <b>STRUT REPLACE</b> button until the lift column completely rises to its upper limit.</p> <p><b>NOTE:</b> The Head-to-Ped cable must be connected between the base and the head for the <b>STRUT REPLACE</b> functionality to work.</p>
<p>5</p>	<p><b>Cable Guards</b></p> <p>Each of the three wheels is equipped with an adjustable cable guard. The guards ensure that when the pedestal moves across the studio floor, it pushes cables or other obstacles aside rather than running over them.</p> <p>The cable guards should be set to the lowest height possible that does not result in the guards themselves contacting the studio floor.</p>
<p>6</p>	<p><b>Connection Panel</b></p> <p>The base's Connection panel offers the following components:</p> <ul style="list-style-type: none"> <li>• <b>FUSE</b> — Fuse hatch for a type T8AH 250V fuse.</li> <li>• <b>ON/OFF switch</b> — Controls power <b>ON</b> (   ) or <b>OFF</b> ( O ) for the pedestal and subsystems connected to the panel.</li> <li>• <b>AC POWER Light</b> — Illuminates when the pedestal's <b>ON/OFF Switch</b> is in the <b>ON</b> position.</li> <li>• <b>INPUT socket</b> — AC power input socket, 100-120VAC.</li> <li>• <b>AUX socket</b> — AC power output socket for subsystems or power bar.</li> <li>• <b>P/T HEAD socket</b> — 10-pin connector for the Head-to-Ped cable that provides power input to the 600 head and data connection from the head to the lift via the pedestal base.</li> </ul> <div data-bbox="609 1075 1052 1543" data-label="Image"> <p>The diagram shows the front panel of the ROSS connection panel. At the top center is the 'ROSS' logo. Below it, from top to bottom, are: a fuse hatch labeled 'T 10A H 250V'; an ON/OFF switch with a vertical bar for 'ON' and a circle for 'OFF'; an AC POWER light; an INPUT socket with specifications 'INPUT: 100-240V~, 8.0A - 4.0A, 50/60 Hz'; an AUX socket with specifications 'AUX: 100-240V~, 4.0A-2.0A (MAX), 50/60 Hz'; and a P/T HEAD socket.</p> </div>
<p>7</p>	<p><b>E-Stop Button</b></p> <p>The Emergency Stop (E-Stop) button immediately disconnects power to the lift and head so that they both immediately stop moving. This ensures maximum safety.</p> <p>To activate, press down on the E-stop button. The head becomes free-wheeling and the lift stays in its current position (although a heavier payload may cause the lift to descend slightly over time). A visual indication that E-Stop is engaged is that the E-stop button is in its lower position and the green LED (input power) on the head is not illuminated.</p> <p>To deactivate the E-Stop, twist and pull the button upwards. Power is restored and the pedestal initializes, which may involve the lift lowering and/or raising to its home position.</p>

## BlackBird C2 Lift

The BlackBird C2 features a two-stage robotic lift that achieves a vertical range of 483 mm (19.0").

**Figure 3** shows that when mounted on a BlackBird pedestal base, the C2 lift has a minimum height of 1315 mm (51.80") and a maximum height of 1798 mm (70.80") to optical center with a CamBot 600 head.

Control of the lift is accomplished using the Lift functions of the control system, like the Ross SmartShell application and/or the Joystick panel. There is no manual control available on the pedestal for controlling the lift, but the CamBot local control box is an optional accessory that enables you to manually control a BlackBird C2 pedestal system locally, using pan bars and the control box itself. See "**Local Control**" on page 3-19 for more information.



**Figure 3** BlackBird C2 Two-stage Robotic Lift

Within the lift, there's a single pressurized pneumatic strut that helps support the weight of the payload. Table 1 shows various models of struts are available for the BlackBird C2 pedestal. The exact model of strut required depends on the intended payload that the pedestal is expected to carry. If you change the weight of the payload, you may require different struts.

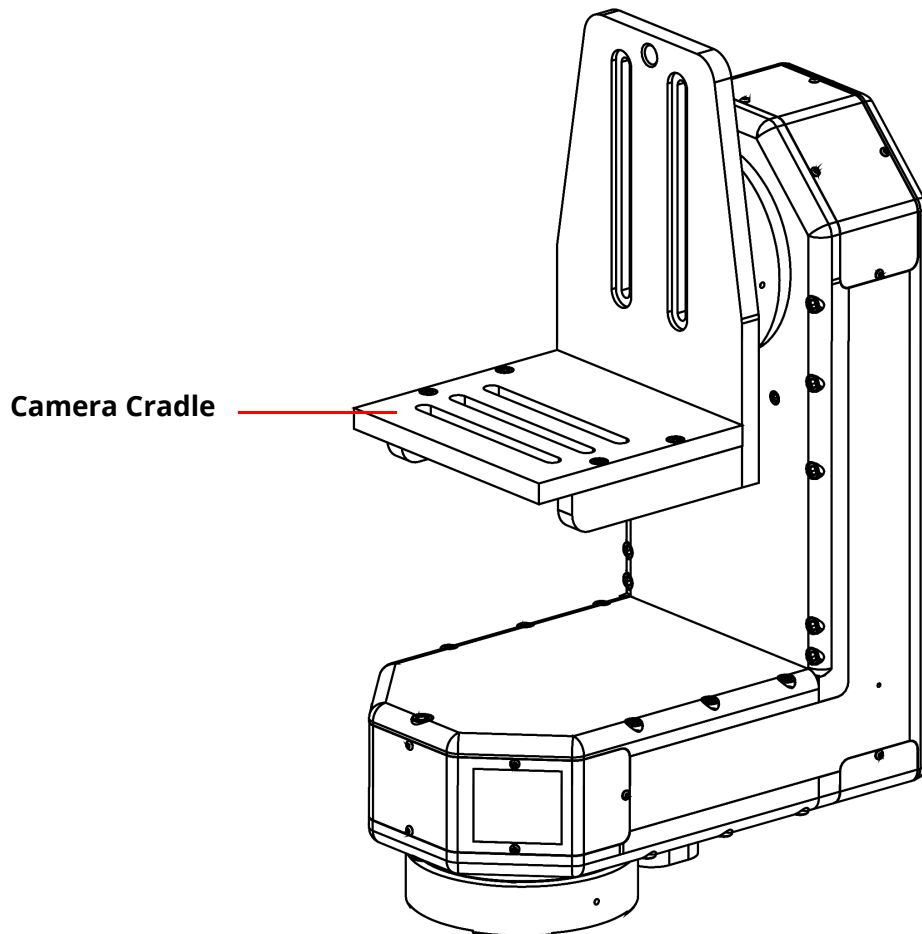
**Table 1 - Struts for the BlackBird C2 Pedestal**

Strut Order Numbers	Payload Weight
CAM-610ST-450N	0 to 45 lbs 0 to 20 kg
CAM-610ST-550N	45 lbs to 80 lbs 20 kg to 36 kg
CAM-610ST-715N	80 lbs to 125 lbs 36 kg to 57 kg
Payload is too high!	Over 125 lbs over 57 kg

## CamBot 600 Head

The BlackBird C2 pedestal is equipped with the CamBot 600 robotic head which allows you to produce smooth and accurate pan and tilt movements using the Ross SmartShell application and/or the Joystick panel.

The 600 head has a net payload capacity of 125 lbs (57 kg) and can handle most of today's studio camera configurations, including ENG/EFP-style cameras and lenses, with full-sized prompters, talent monitors, clocks and tally lights.



**Figure 4** The CamBot 600 Head

Figure 5 shows the Cambot 600 head's connection panel.

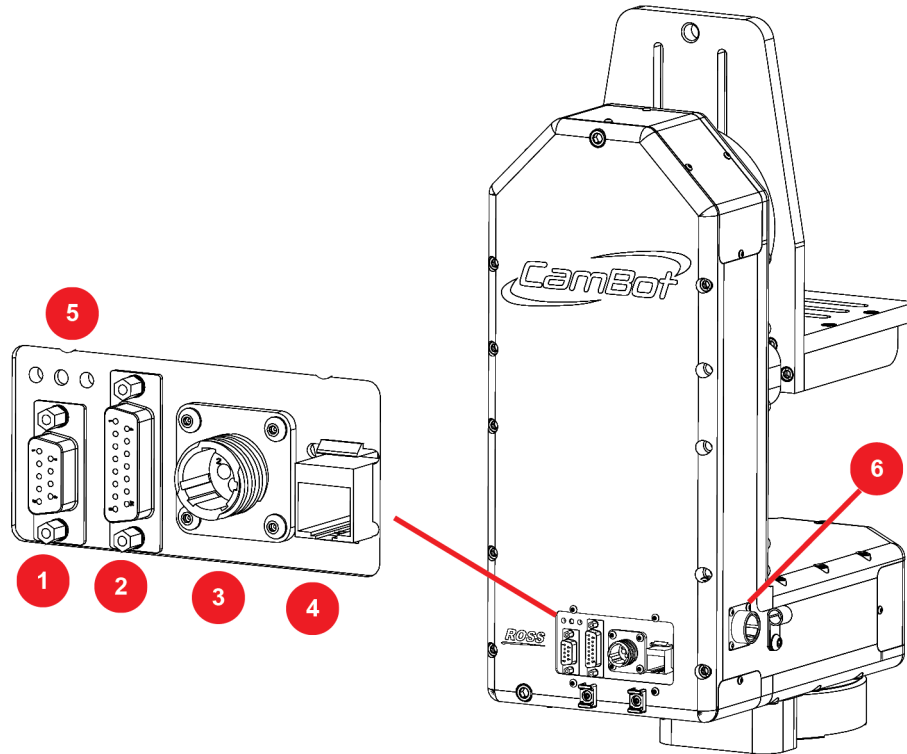


Figure 5 CamBot 600 Head Connection Panel

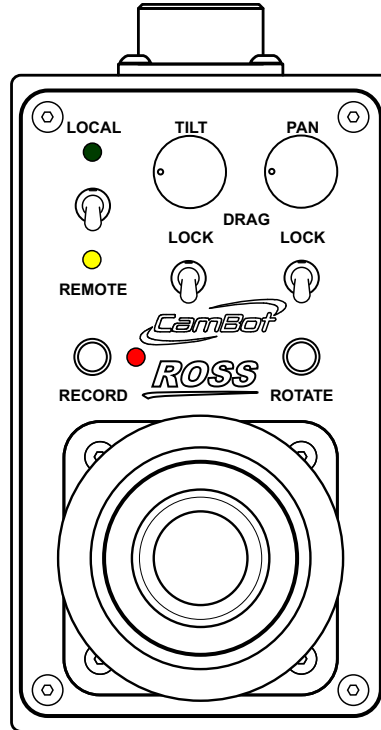
Label	Description
1	<b>Digital Lens Port</b> Connect the lens cable to permit the pedestal's head to control the digital zoom and focus of your camera.
2	<b>Local Control Port</b> A dual function port for both analog lens control or Local control.
3	<b>Power Input (Standalone)</b> Not used.
4	<b>Ethernet Port</b> Receives an Ethernet cable from the Robotics Server.
5	<b>LED Status Lights</b> <ul style="list-style-type: none"> <li>• <b>Green</b> - Illuminates when power is entering the head.</li> <li>• <b>Amber</b> - Flashes when data connection is active between the head and the Robotics Server.</li> </ul>
6	<b>Power/Data Input (Head)</b> Power input via the Head-to-Ped cable from the BlackBird C2 pedestal base. The same cable and connection provides the data connection from the head to the lift.

## Steering Ring

The handheld steering ring (5110AR-119-01) is an optional accessory available on the BlackBird C2 pedestal. It attaches to the collar of the lift and provides you with a convenient and ergonomic handle from which you can easily push, pull or turn the pedestal into position.

## Local Control Box and Pan Bars

The CamBot local control box (CAM-UNI-LC-PTL) and pan bars (CAM-605-MP) are optional accessories that enable you to manually control a BlackBird C2 pedestal system locally. When **Local** control is enabled on the local control box, the joystick can be used to raise and lower the lift column. Local control mode also allows you to use the pan bars to manually pan or tilt the head. See “**Local Control**” on page 3–19 for more information.



**Figure 6 - The Local Control Box**

## Site Requirements

The following documents provide information about site requirements for installing and using Blackbird C2 pedestals and compatible control systems:

- **CamBot Studio Site Requirements (5100DR-022-xx)**  
Applies to Ross Robotics systems that use CamBot Studio equipment.
- **Control Room Site Requirements for Standard Control Station (5100DR-021-xx)**  
Applies to Ross Robotics systems that use a Standard SmartShell Control Station (RRB-CTL-3 or RRB-CTL-6).
- **Control Room Site Requirements for Standalone Control Station with Integrated Server (5100DR-032-xx)**  
Applies to Ross Robotics systems that use a Standalone SmartShell Control Station with Integrated Server (RRB-CTL-3-SRV or RRB-CTL-6-SRV).

To obtain electronic copies of these documents, contact your Ross Video sales representative.



# Control Systems

CamBot 600 heads feature an open API that allows them to control the lift and head via a variety of technologies, including Ross Video's SmartShell control application and joystick panel, production switchers such as Ross Video Acuity, and broadcast automation systems such as Ross Video OverDrive. They can also be manually controlled using the Local Control Box, which is an optional accessory that can be mounted on pan bars attached to the pedestal's payload.

This section contains the following topics about controlling BlackBird C2 pedestals:

- "SmartShell Control Application" on page 3-17
- "The Joystick Panel" on page 3-18
- "Local Control" on page 3-19

## SmartShell Control Application

The main interface for controlling Ross Video BlackBird C2 pedestals is SmartShell, an easy-to-use touch-screen interface that enables you to control camera systems automatically using stored presets, and manually using a joystick panel and/or buttons in the user interface.

The SmartShell computer comes with a touch screen monitor. You can also use the provided mouse and keyboard.

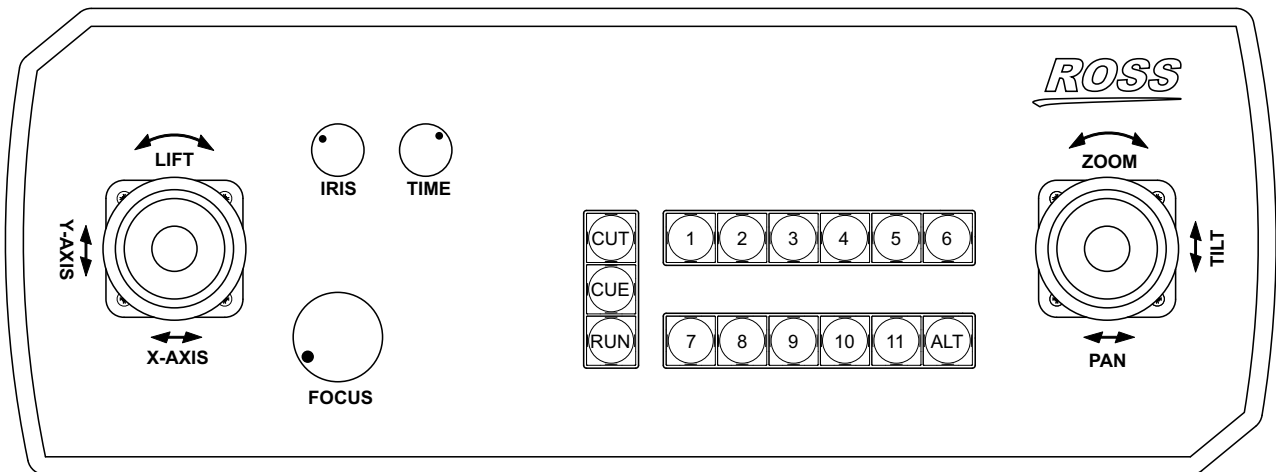
See the *SmartShell User Guide (5100DR-002-xx)* for detailed information.



Figure 1 - The SmartShell Control Application (in Matrix View for Panel Mode)

## The Joystick Panel

You can remotely control BlackBird C2 pedestals using the joystick panel (see **Figure 2**). The joystick panel enables you to move multiple axes of a camera system simultaneously, for smooth camera operation.



**Figure 2** - Joystick Panel (may not appear exactly as shown)

During a show, operators typically use the joystick panel in conjunction with the matrix view in SmartShell. For more information, see the **SmartShell User Guide (5100DR-002-xx)**.

### Joystick Panel Controls

This section describes how the joystick controls work. Joystick controls include:

- **Camera Selection buttons (1 - 11)** — Each button selects/deselects a camera to control. Only one camera can be selected at a time.
- **Left Joystick** — Controls lift column height.
- **Right Joystick** — Controls pan, tilt, and lens zoom.
- **Joystick buttons** — The right joystick button temporarily disables variable zoom (ZOOMVAR). The left joystick button is unassigned.
- **IRIS knob** — Adjusts the iris setting.
- **TIME knob** — Adjusts the recall duration for a preset when you are adding or editing it, or just before you run it. Also adjusts the duration of an action while it is running.

Depending on how your system is configured by your administrator, the **TIME** knob works in one of the following ways:

- › To adjust the recall duration of a preset while you are adding, editing, or just about to run it, turn the **TIME** knob. To change the duration of a preset, move, or macro while it is running, press and hold the **ALT** button and turn the **TIME** knob.
- › To adjust the recall duration of a preset while you are adding, editing, or just about to run it, press and hold the **ALT** button and turn the **TIME** knob. To change the duration of a preset, move, or macro while it is running, turn the **TIME** knob.
- **FOCUS knob** — Rotate to adjust the lens focus, or press the knob enter or exit Quick Focus mode.
- **CUT button** — Moves the camera to the selected preset position as quickly as possible. This button is operational for SmartShell Panel mode only.
- **CUE button** — Prepares a move before you recall it. This button is operational for SmartShell Panel mode only.
- **RUN button** — Moves the camera to the selected preset or move position in the specified time period, if possible. This button is operational for SmartShell Panel mode only.
- **ALT button** — Enables you to perform alternative functions, including the following:
  - › Enables the **TIME** knob to do one of the following, depending on how the system is configured:

- › Modify the duration of a preset, move, or macro while it is running. To modify the duration, press and hold the **ALT** button, and then turn the **TIME** knob clockwise to increase the duration or counter-clockwise to decrease it.
- › Modify the duration of a preset when you are adding, editing, or just about to run it. To modify the duration, press and hold the **ALT** button, and then turn the **TIME** knob clockwise to increase the duration or counter-clockwise to decrease it.
- › Enables the alternative cue/cut speed feature for actions that involve cueing the camera or cutting to a preset.

**Tip:** When operating a CamBot, the **ALT** button is normally yellow. When you press the button, it turns green unless the camera is on-air, in which case it turns red. The red on-air indicator applies only if your system includes tally integration.

## Local Control

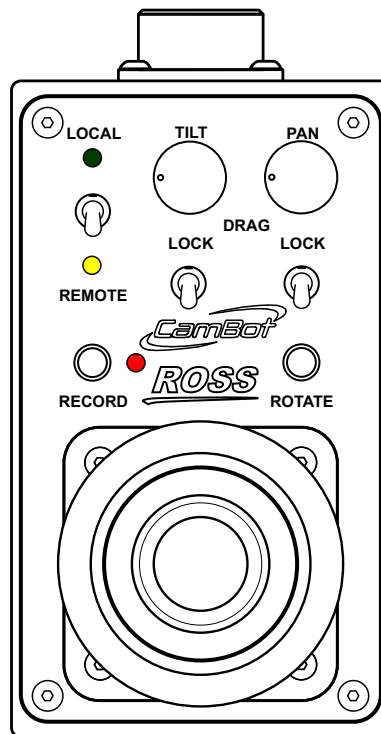
The CamBot local control box is an optional accessory that enables you to manually control a BlackBird C2 pedestal system locally, using pan bars and the control box itself. When you use the local control box, all commands from other control systems are ignored.

The local control box enables you to switch seamlessly between remote and local control without having to power down the pedestal.

This section explains how to perform tasks using the local control box, including:

- “**Switching Between Remote Control and Local Control**” on page 3-20
- “**Raising and Lowering the Lift Column**” on page 3-21
- “**Panning and Tilting the Head**” on page 3-21
- “**Adjusting Drag for Pan and/or Tilt**” on page 3-22
- “**Locking and Unlocking Tilt and/or Pan**” on page 3-22

**Figure 3** shows the local control box.



**Figure 3** - The Local Control Box

**Notes:**

- The local control box does not control lens functions, such as zoom, focus, and iris. These features can be operated via controllers mounted to the pan bars (if equipped).
- The **RECORD** button is not operational. It is reserved for future use.

### Switching Between Remote Control and Local Control

Switching to local control enables you to control the pedestal system locally, using pan bars and the local control box. Switching to remote control allows the SmartShell application or an automation system to take control of the camera system.

LEDs above and below the **LOCAL/REMOTE** switch indicate the current control status. Green indicates local control, and yellow indicates remote control. **Figure 4** shows the **LOCAL/REMOTE** switch.

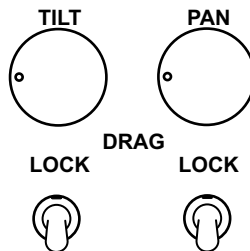


*Figure 4 - The LOCAL/REMOTE Switch*

#### To Switch from Remote Control to Local Control

1. Ensure that the camera system is at rest, meaning that
  - it is not moving,
  - it is not running a preset,
  - no automation system is moving it, or is about to move it, and
  - no one is operating it manually using the joystick panel.
2. On the local control box, put the tilt and pan lock switches in the unlocked (downward) position. This step ensures that you will be able to move the head freely as soon as you switch to local control.

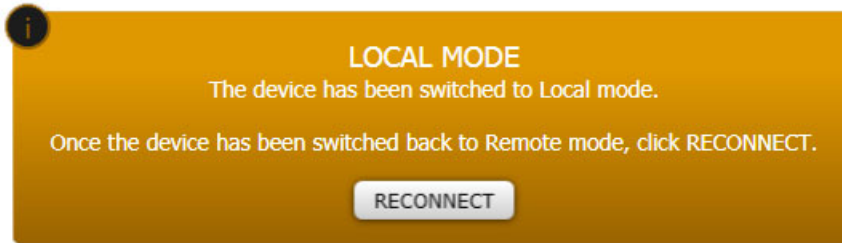
**Tip:** The lock switches are below the **TILT** and **PAN** drag knobs, as shown in **Figure 5**.



*Figure 5 - Tilt and Pan Lock Switches, in the Unlocked Position*

3. Without touching the joystick on the local control box, flip the **LOCAL/REMOTE** switch to **LOCAL** and then wait at least two seconds for the local control box to take control of the pedestal system. After you flip the switch, the green **LOCAL** LED illuminates. You can now control the camera system manually using the local control box and pan bars.

In SmartShell, the following message appears:



**Figure 6** - LOCAL MODE Message, Indicating that the BlackBird C2 Pedestal is under Local Control

#### To Switch from Local Control to Remote Control

1. Flip the **LOCAL/REMOTE** switch to the **REMOTE** (bottom) position.

The yellow LED illuminates.

**IMPORTANT:** After you switch to remote control, do not attempt to move the camera system using pan bars.

2. In SmartShell, tap **RECONNECT**.

The **OPERATE** button appears.

3. Click **OPERATE** to take control of the camera system.

You can now control the camera system using SmartShell and the joystick panel.

#### Raising and Lowering the Lift Column

You can use the joystick on the local control box to raise and lower the lift column.

##### To raise or lower the lift column:

- Twist the joystick counter-clockwise to raise the lift column, or clockwise to lower it.

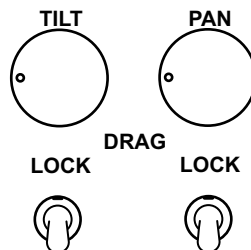
#### Panning and Tilting the Head

You can use the pan bars to pan and/or tilt the head.

##### To pan and/or tilt the head:

1. Ensure the tilt and pan lock switches are in the correct positions:
  - If you want to be able to pan and tilt the head freely, ensure both switches are in the unlocked (downward) position.
  - If you want to restrict movement of either pan or tilt, ensure the corresponding switch is in the locked (upward) position.

**Tip:** The lock switches are below the **TILT** and **PAN** drag knobs, as shown in **Figure 5**.



**Figure 7** - Tilt and Pan Lock Switches, in the Unlocked Position

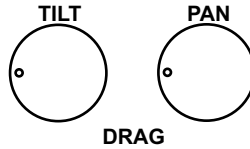
**IMPORTANT: NEVER** try to force the head to move in a locked direction. For example, if the pan lock switch is locked, do not pan. You must unlock the pan switch before you pan. Forcing the head to move in a locked direction can seriously damage the equipment.

- Use the pan bars to pan and/or tilt the head.

**Tip:** You can adjust the amount of resistance you feel when you pan and tilt. For more information, see “**Adjusting Drag for Pan and/or Tilt**” on page 3–22.

## Adjusting Drag for Pan and/or Tilt

You can use the **TILT** and **PAN** drag knobs to adjust the amount of resistance you feel when you pan and tilt.



**Figure 8** - TILT and PAN Drag Knobs

### To adjust the drag for pan and/or tilt:

- Turn the **TILT** knob to adjust tilt drag, or the **PAN** knob to adjust pan drag.

**Tip:** Turning the knobs clockwise increases drag. Turning them counter-clockwise decreases drag.

## Locking and Unlocking Tilt and/or Pan

You can lock tilt and/or pan to prevent movement in one direction. For example, if you want to pan smoothly without any tilt motion, you can lock tilt.

You can also lock both tilt and pan to keep the camera system in its current position. This allows you to set up a stationary camera shot and step away, while maintaining local control to prevent any other control system from moving the camera.

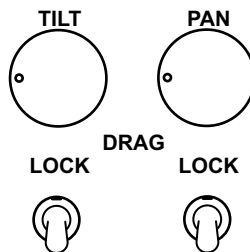
**Note:** The tilt and pan locks affect only local control. They do not affect the ability of the SmartShell application or an automation system to move the head when the camera system is in remote control mode.

### To lock or unlock tilt and/or pan:

- Flip the desired lock switch to the locked (upwards) position, or unlocked (downwards) position.

**Tip:** The tilt lock switch is below the **TILT** drag knob. The pan lock switch is below the **PAN** drag knob.

**Figure 9** shows the tilt and pan lock switches.



**Figure 9** - Tilt and Pan Lock Switches (Below TILT drag knob and PAN drag knob)

# Maintenance

BlackBird C2 pedestals are designed to require very little maintenance, but there are a few preventative maintenance tasks that you can perform to minimize wear and ensure proper functioning.

This section contains the following topics about maintaining BlackBird C2 pedestals:

- **“General Inspection and Cleaning”** on page 4-23
- **“Cleaning the Cable Guards and Wheels”** on page 4-24
- **“Balancing the Payload”** on page 4-25
- **“Removing the Head”** on page 4-27
- **“Replacing the Pneumatic Strut”** on page 4-28

## General Inspection and Cleaning

**Perform the following inspection and cleaning tasks periodically on the BlackBird C2 pedestal:**

- **Clean the pedestal and robotic head.**

Turn off the pedestal and then use a slightly water-dampened rag and a mild liquid detergent to clean the pedestal and the head.

Do not use abrasive cleansers or chemical solvents!

Do not get any connectors wet!

Ensure that the pedestal and head are completely dry before turning it back on!

- **Inspect cables for damage**

Inspect the bundle of cables that extends from the pedestal, looking for signs of excessive wear on the cable sleeve.

If the cable sleeve is damaged, inspect the cables to ensure that no conductors are exposed or damaged. Replace any damaged cables or cable sleeves promptly. Do not operate the pedestal if any conductors are exposed!

Inspect all points where cables connect to the pedestal, the head, or the payload. Make sure that the connectors are mated properly.

Check that all cables are properly dressed, so that strain on connectors is eliminated as much as possible, and that the cables have adequate slack to allow for the full range of robotic motion.

- **Check the mounting bolts**

Periodically check that the bolts holding the payload together are tight. Also check the bolts that fasten the payload to the camera cradle, the bolts that fasten the camera cradle to the head, and the bolts that fasten the head to the lift column. Checking the mounting bolts is especially important in the first few weeks after installing the payload.

- **Check the clearance of the cable guards**

Cable guards are installed on each of the three caster wheels. They ensure that when the pedestal moves across the studio floor, it pushes cables aside rather than running over them.

The cable guards should be set to the lowest height possible that does not result in the guards themselves contacting the studio floor.

To check cable guard height, move the pedestal to all areas of the studio while observing the clearance between the cable guards and the floor.

Generally, the height of the cable guards do not require adjustment after initial setup. However, if adjustments are necessary, use a 3/32" hex key to adjust the height of the cable guards.

- **Inspect wheels for dirt and debris**

As wheels roll across the studio floor, they accumulate dirt and debris, which can impair smooth motion.

Visually inspect the wheels to detect the presence of foreign material.

If the wheels require cleaning, follow the directions in the section, **“Cleaning the Cable Guards and Wheels”** on page 4-24.

## Cleaning the Cable Guards and Wheels

As the pedestal moves across the studio floor, the cable guards and wheels may accumulate dirt and debris. Cleaning the guards and wheels periodically helps maintain the smooth motion and positional accuracy of the pedestal.

**NOTE:** For optimal performance, it's important to keep the pedestal wheels clean. Sweep and mop the studio floor regularly. Avoid moving the pedestal across a dirty floor. Also, periodically replace worn spike marks with new spike tape, and remove all old tape residue from studio floors.

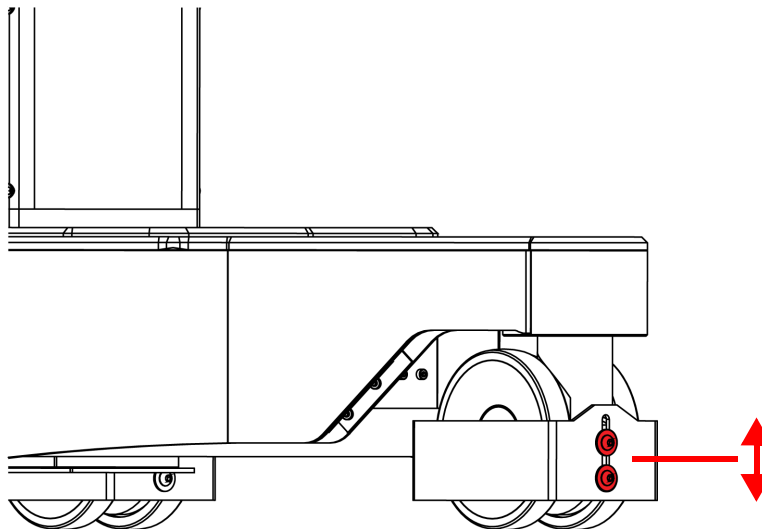
The easiest way to clean the wheels is to wipe down the exposed portion of each wheel and then move the pedestal manually to expose a different portion of the wheel's surface.

### Before you begin:

- Gather the following materials:
  - › 3/32" hex key (also known as a hexagonal wrench, or Allen key)
  - › Protective gloves
  - › Mild liquid detergent
    - DO NOT use harsh chemical cleaners such as ammonia. Harsh chemicals can damage the wheels.
  - › A clean bucket, a rag, and access to warm water.
    - DO NOT use steel wool or other abrasive tools that can damage the wheels.
- Move the pedestal to a clean area of the studio floor and ensure that there is ample working space all around the pedestal.
- Ensure that the payload is balanced and that the anti-tip feet are lowered to prevent the possibility of tipping.
- Disengage the wheel locks on each of the pedestal's wheels.
- Set the ON/OFF switch on the pedestal base to the OFF ( O ) position.

### To clean the cable guards:

1. Use a 3/32" hex key to loosen the screws that fasten cable guards to the wheel unit. Each cable guard has two screws. Loosen the screws just enough to allow the cable guard to move (see **Figure 1**).



**Figure 1** Adjusting the height of the cable guards

2. Raise the cable guard to the highest position, and then tighten the screws just enough to hold the pieces in position. Do not over-tighten.
3. Put on protective gloves, and then clean all three cable guards by wiping the bottom edge of each of the cable guards using a cloth, warm water, and mild detergent, such as dish detergent.

**IMPORTANT:** Wear protective gloves. Debris on the wheels may be sharp. Glass shards from broken bulbs may be embedded in the wheels.

4. Lower the guards to their original position by using a 3/32" hex key to loosen the screws that fasten the cable guards.

The cable guards prevent the pedestal from running over cables. The guards should be set as low as possible, but must not bottom out as the pedestal moves across the studio floor.

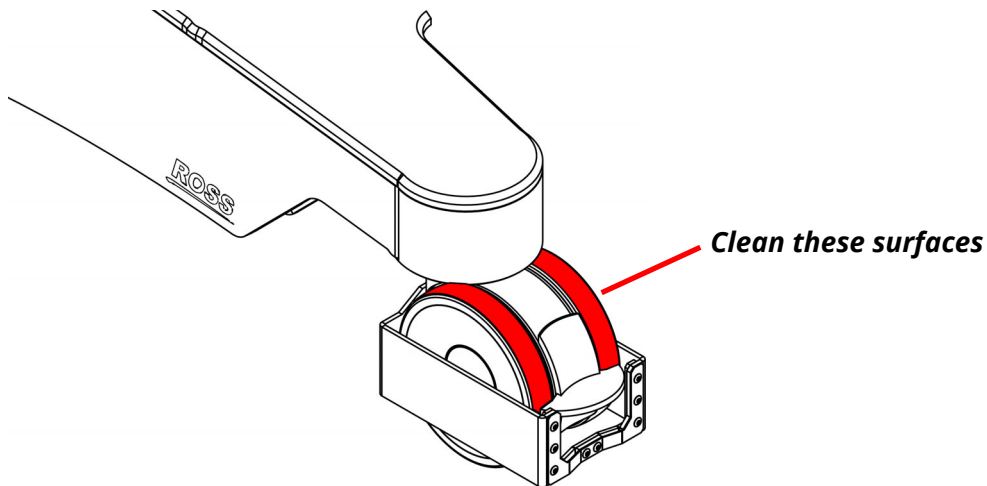
5. Tighten the screws to secure the guards. Do not over-tighten.

**To clean the wheels:**

1. Put on protective gloves, and then clean portion of the wheel that is exposed above the cable guard using a cloth, warm water, and mild detergent (see **Figure 2**).

**IMPORTANT:** DO NOT use harsh cleaning agents on the wheels. Harsh chemicals or solvents such as acetone can seriously and permanently damage wheel material. Use only a mild detergent, such as dish detergent.

**IMPORTANT:** Wear protective gloves. Debris on the wheels may be sharp. Glass shards from broken bulbs may be embedded in the wheels.



**Figure 2** Clean the exposed portion of the wheel's surface

2. Manually move the pedestal base forward or backward to expose another portion of the wheel's surface and wipe the wheel's surface using a cloth, warm water, and mild detergent.
3. Repeat **Step 2** until all of the wheel's surface has been cleaned.
4. Repeat the cleaning process on the other two wheels.

## Balancing the Payload

For best performance, and to reduce wear on the head's drive train, you must ensure that the payload's center of gravity is aligned with the tilt axis.

Balance the payload when installing a new head, and whenever you replace, add, or reposition any payload components. Balance the payload horizontally first, and then vertically.

The head and camera cradle are designed to make balancing easy. **Figure 3** and the following lists identify the payload balancing adjustment features:

**Horizontal adjustment components**

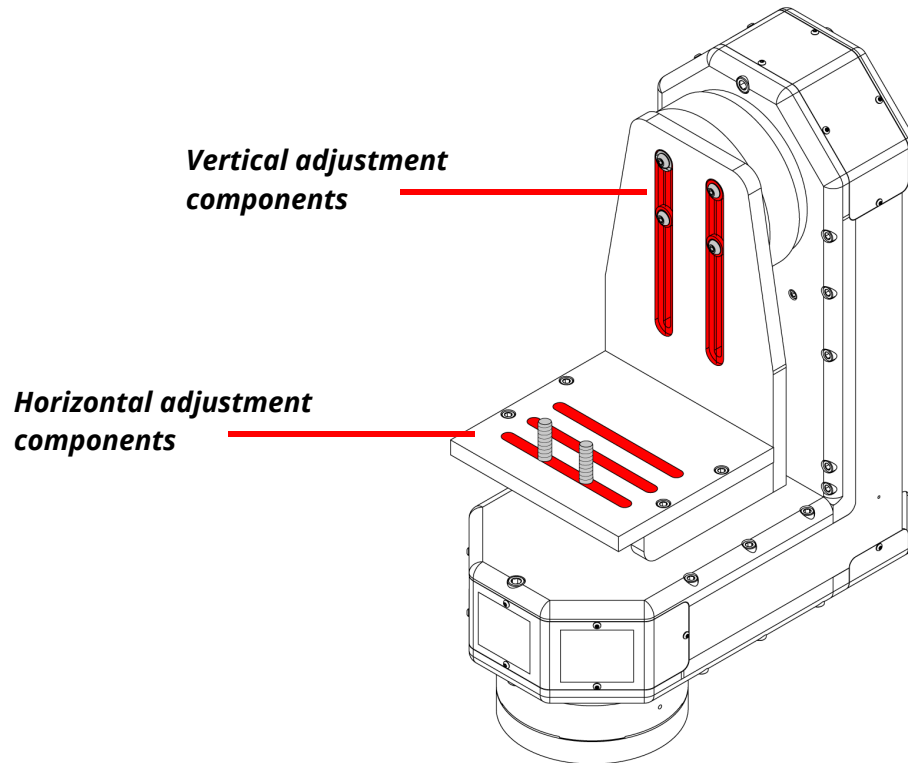
- Depending on the camera model, two or more screws (with washers) to secure the camera to the camera cradle.
- Three horizontal slots on the camera cradle allow for horizontal fine-tuning.

**IMPORTANT:** Always use two (or more) screws in a single slot to fasten the camera to the cradle.

### Vertical adjustment components

- Four screws (with washers) that join the cradle to the head allow for vertical adjustment (up / down)
- A series of threaded holes allow the screws to be repositioned for major vertical adjustments.
- Two vertical slots on the camera cradle allow for vertical fine-tuning.

**IMPORTANT:** Always use four screws to fasten the camera cradle to the head (two per slot).



**Figure 3** Payload balancing adjustment components

#### To balance the payload horizontally:

1. Ensure that there's no power to the head by disconnecting the Head-to-Ped cable from the head's connection panel.
2. Manually tilt the payload so that it is horizontal, and then release it.
3. If the payload does not tilt, it is horizontally balanced. Skip the remaining steps, and proceed to the vertical balancing procedure below.
4. Use the horizontal adjustment components (**Figure 3**) to move the payload away from the direction it tilted, and then test again.
5. Continue adjusting and testing until the payload is horizontally balanced.

**Tip:** After you balance the payload horizontally, use a grease pencil or marker to mark the position of the payload on the camera cradle.

#### To balance the payload vertically:

1. Manually tilt the payload approximately 40° (but not as far as it can go), and then release it.
2. If the payload does not move, it is vertically balanced. Skip the remaining steps in this procedure.
3. Based on the direction the head tilts, note whether it needs to be raised or lowered:
  - › If the payload tilts back towards horizontal, it is mounted too low, and must be raised.
  - › If the payload continues tilting away from horizontal, it is mounted too high, and must be lowered.
4. Use the vertical adjustment components (**Figure 3**) to raise or lower the payload as required, and then test again.

**Tip:** If you cannot easily access the vertical adjustment screws, you may need to temporarily remove the payload from the camera cradle. Be sure to return it to its original horizontal position.

5. Continue adjusting and testing until the payload is vertically balanced.

**Tip:** After you balance the payload vertically, use a grease pencil or marker to mark the position of the cradle mount screws on the cradle.

## Removing the Head

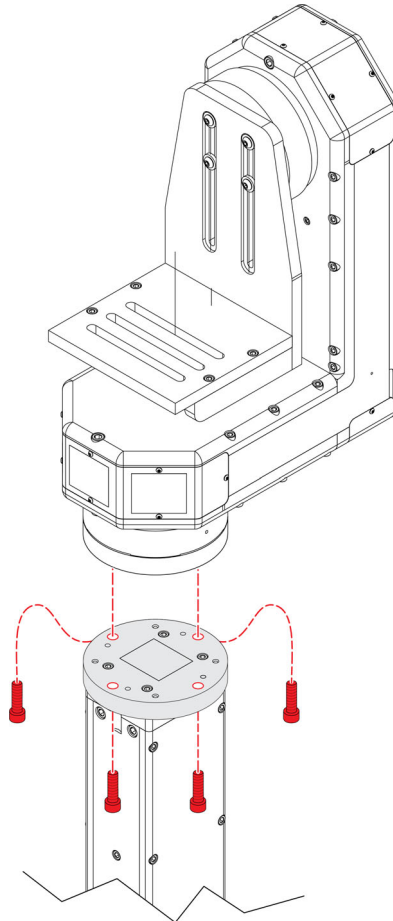
### Before you begin:

- Tools required includes a 5/16" hex key (also known as a hexagonal wrench, or Allen key).
- Two people are required to remove the head.

### To remove the head:

1. Move the pedestal to an open area so you have easy access to all sides.
2. Use the control system to lower the lift column all the way to allow easy access to the payload.
3. Remove the payload.
4. Do the following to remove the head:
  - a. Disconnect all cables from the head.
  - b. Have someone hold the head steady to prevent it from falling.
  - c. Use a 5/16" hex key to remove the four screws that fasten the head to the lift column.

**NOTE:** In **Figure 4**, the screws and the holes in the strut plate at the top of the lift column are shown as red.



**Figure 4** - Removing the 600 Head from the Lift Column (4 screws; 5/16" hex key required)

- d. Remove the head and place it gently on a sturdy surface.
- e. Turn the pedestal **OFF ( O )**.

## Replacing the Pneumatic Strut

The lift on the BlackBird C2 pedestal contains one pressurized pneumatic strut that helps support the weight of the payload. Struts of various force ratings are available from Ross Video. If you change the weight of the payload, you may require a different model of strut.

Table 1 lists the correct struts for each pedestal model and payload.

**Table 1 - Selecting the Appropriate model of Strut**

Strut Order Numbers	Payload Weight
CAM-610ST-450N	0 to 45 lbs 0 to 20 kg
CAM-610ST-550N	45 lbs to 80 lbs 20 kg to 36 kg
CAM-610ST-715N	80 lbs to 125 lbs 36 kg to 57 kg
Payload is too high!	Over 125 lbs over 57 kg

After years of regular use, the strut may become less efficient and may need to be replaced. The payload should maintain its position when you turn off the pedestal. If the payload drops significantly, the strut is underpowered, either because the ratings are not appropriate for the payload, or because it is worn out. This section describes how to replace the pneumatic strut.

### Before you begin:

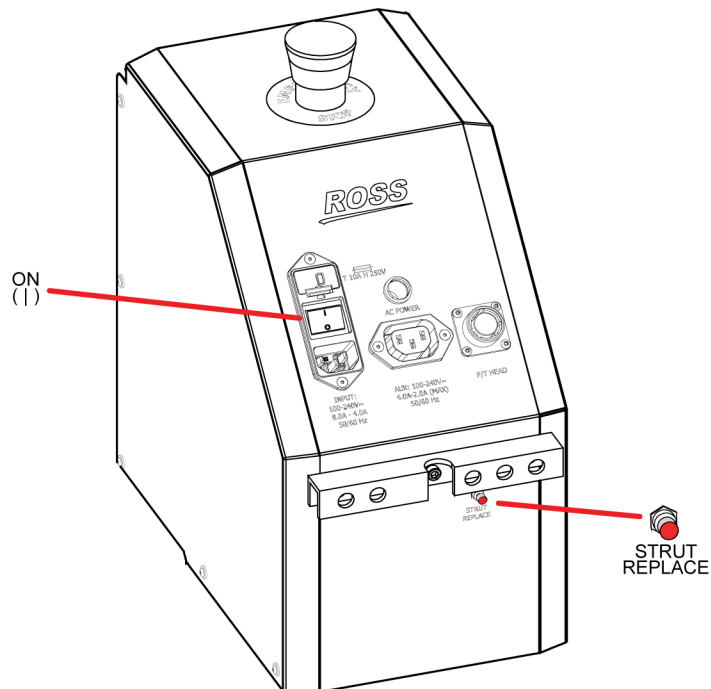
- The strut is installed internally. It extends from an indentation in the base plate of the pedestal to an indentation in the top plate of the lift column. The steps in procedure below refer to this plate as the “strut plate”.
- Replacing the strut requires two people, and takes approximately 45 minutes.
- Tools required include 3/16” and 5/16” hex keys (also known as hexagonal wrenches, or as Allen keys).

### To replace the pneumatic strut:

1. Move the pedestal to an open area so you have easy access to all sides.
2. Locked the three wheels so that the pedestal is stationary and secure.
3. Lower the lift column all the way to allow easy access to the payload.
4. Remove the payload.
5. Do the following to remove the head:
  - a. Have someone hold the head steady to prevent it from falling.
  - b. Use a 5/16” hex key to remove the four screws that fasten the head to the lift column.

**NOTE:** In **Figure 5**, the screws and the holes in the strut plate at the top of the lift column are shown as red.

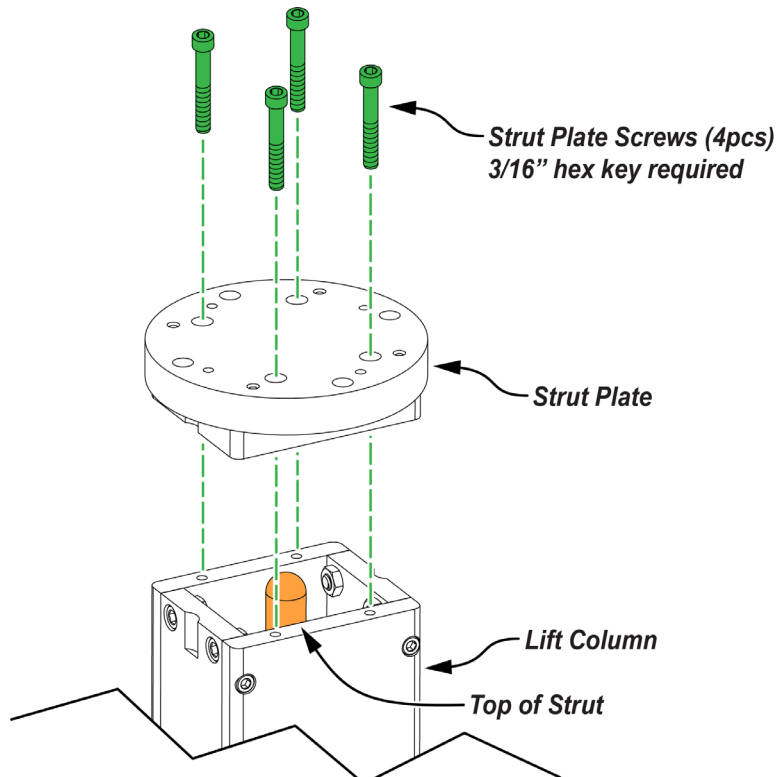




**Figure 6 - The STRUT REPLACE Button on the Connection Panel**

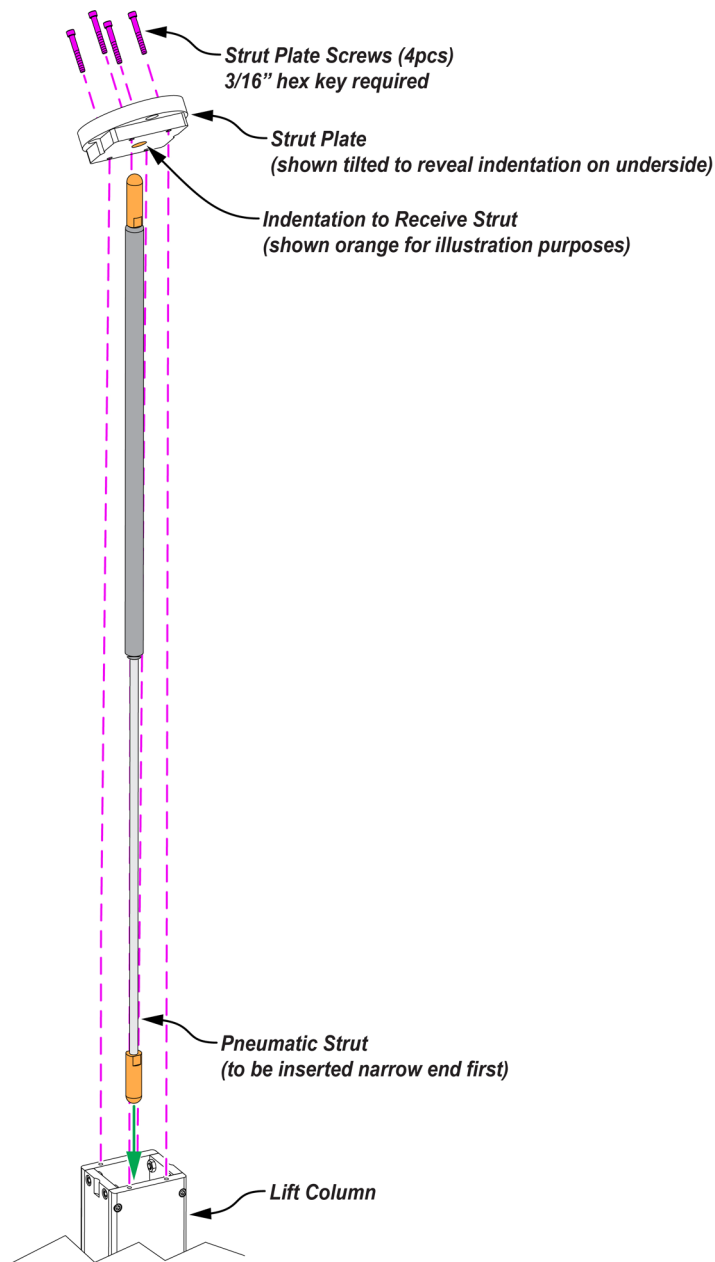
- b. Continue to hold the **STRUT REPLACE** button until the lift column starts to rise, and then release the button.  
The lift column rises to the highest position. This reduces the compression force on the strut so it can be removed.

- 8. Use a 3/16" hex key to remove the four screws that fasten the strut plate to the top of the lift column. In **Figure 7**, these screws are shown as green. Retain the screws for re-installation later.



**Figure 7 - Removing the Strut Plate Screws (4 pcs)**

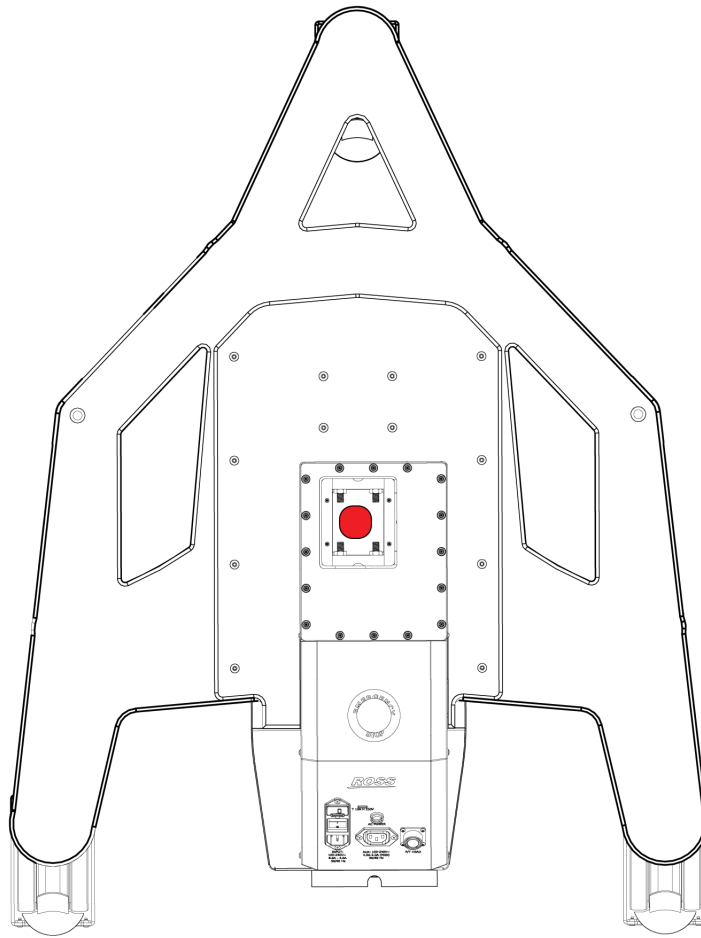
9. Lift the strut out of the lift column.
10. Examine the new strut, noting that one end is narrower than the other.
11. Insert the new strut into the lift column, narrow end first, as shown in **Figure 8**.



**Figure 8** - Inserting the Pneumatic Strut (narrow end first)

12. Carefully seat the strut into the semi-spherical strut-locating indentation in the base plate of the pedestal. Move the strut side-to-side until you feel it settle into its indentation.

**NOTE:** **Figure 9** is a top-down view of the two-stage pedestal. The indentation is shown as a red circle.



**Figure 9** - Top-down View of a BlackBird C2 pedestal with two-stage lift, showing Strut-Locating Indentation in Red

13. Lower the strut plate into position, ensuring that the spherical end of the strut aligns with the matching indentation on the underside of the plate.

**IMPORTANT:** Be careful not to dislodge the bottom of the strut from the strut-locating indentation.

14. Use a 3/16" hex key to reinstall the four strut plate screws.

**IMPORTANT:** Be careful not to dislodge the top or bottom for the strut from the strut-locating indentations.

**IMPORTANT:** Tighten the screws in stages. Tighten each screw a few turns, and then repeat. Ensure the strut plate remains horizontal as you tighten the screws, to prevent the strut from dislodging from the strut-locating indentation.

As you tighten the screws, the strut plate compresses the struts slightly. Ensure that all screws are equally tight.

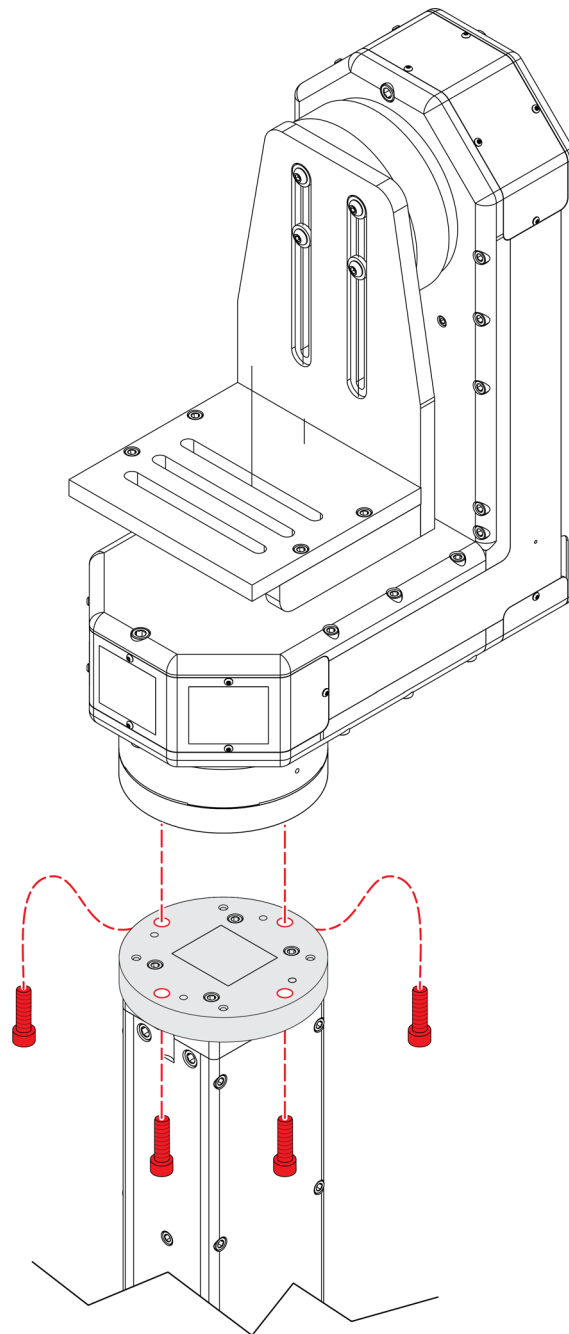
15. Turn the pedestal **OFF ( O )**, wait a few seconds, and then turn it **ON ( | )**.

The pedestal initializes, lowering and then raising the lift column.

16. Using the control system, lower the lift to its lowest position.

17. Turn the pedestal's power switch to **OFF ( O )**.

18. Reinstall the head.
  - a. Have someone hold the head steady to prevent it from falling.
  - b. Align the holes and use a 5/16" hex key to fasten the four screws that secure the head to the lift column (**Figure 10**).



**Figure 10** - Fasten the 600 Head to the Lift Column (4 screws; 5/16" hex key required)

**19.** Install the payload.

Dress the cables properly, so that strain on connectors is eliminated as much as possible, and that the cables have adequate slack to allow for the full range of robotic motion.

**20.** Turn the pedestal's power switch to **ON** ( | ).

The pedestal initializes, which results in the telescopic lift column moving slightly up and down.

# Technical Specifications

This section contains technical specifications for BlackBird C2 pedestal, including the C2 two-stage lift and CamBot 600 head. It includes the following sub-sections:

- “**Specifications Table**” on page 5–34
- “**Physical Dimensions**” on page 5–35

## Specifications Table

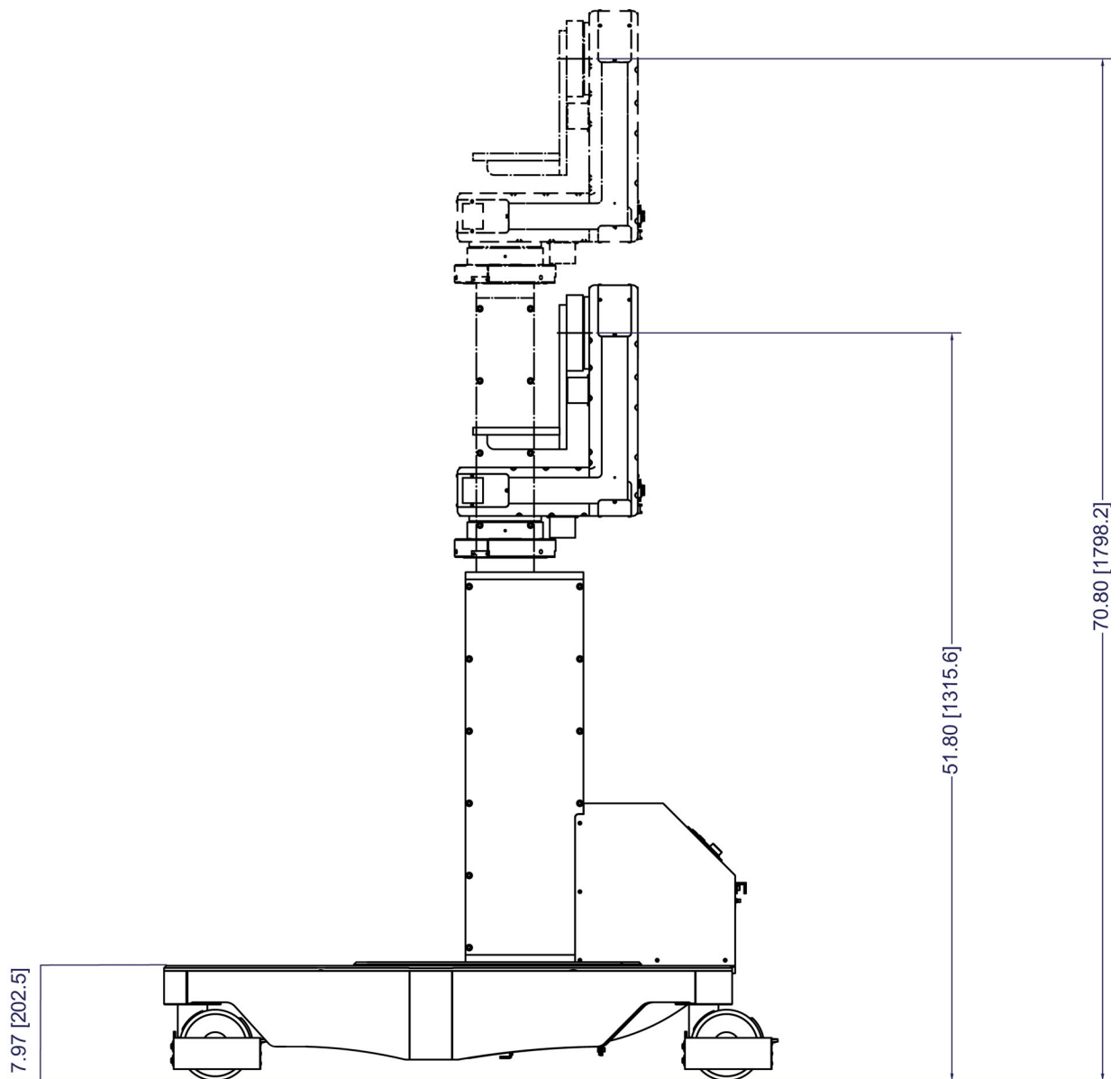
The following tables lists technical specifications for the BlackBird C2 pedestal, including the C2 two-stage lift and CamBot 600 head.

Property	Measurements / Values
<b>General Properties</b>	
<b>Lift Column Type</b>	CamBot C2 Two-stage
<b>Robotic Head</b>	CamBot 600
<b>Lift Repeatability</b>	<b>Pan/Tilt:</b> <0.02 degrees
<b>Maximum Payload Capacity</b>	125 lbs (57 kg)
<b>Maximum Speed</b>	
<b>Pan (degrees/sec)</b>	90 degrees per second
<b>Tilt (degrees/sec)</b>	90 degrees per second
<b>Lift</b>	5" (127 mm) per second
<b>Height</b>	
<b>Pedestal and Lift Without Head</b>	min 37.2" (945 mm) max 56.0" (1422 mm)
<b>Pedestal and Lift With Head</b> (without camera cradle)	min 55.4" (1407 mm) max 74.2" (1884 mm)
<b>Head Only</b> (without camera cradle)	17.7" (449 mm)
<b>Distance from Floor to Tilt Axis</b>	min 52.0" (1321 mm) max 70.8" (1798 mm)
<b>Distance from Floor to Cradle</b> (the surface to which payload is mounted) Payload must be balanced around the tilt axis. Balancing the load determines the cradle position in relation to the tilt axis.	
<b>With Lift Column at Min Height</b>	min 45.4" (1145 mm) max 49.1" (1246 mm)
<b>With Lift Column at Max Height</b>	min 67.8" (1723x mm) max 71.5" (1815 mm)
<b>Length and Width of Pedestal Base</b>	length 42.5" (1081 mm) width 32.0" (813 mm)
<b>Weight (Base + Lift + Head)</b>	281.5 lbs (127.7 kg)
<b>Range of Motion</b>	
<b>Pan Axis</b>	+/- 178 degrees
<b>Tilt Axis</b>	+/- 90 degrees

Property	Measurements / Values
Lift Axis (vertical stroke)	19" (48.3 cm)
<b>Power Consumption</b>	
Total for pedestal, head, and accessories (prompter, etc)	1050 Watts (maximum)
Pedestal and head only	450 Watts (maximum)
Additional power available through auxiliary power socket, for prompter and other accessories.	500 Watts (maximum)

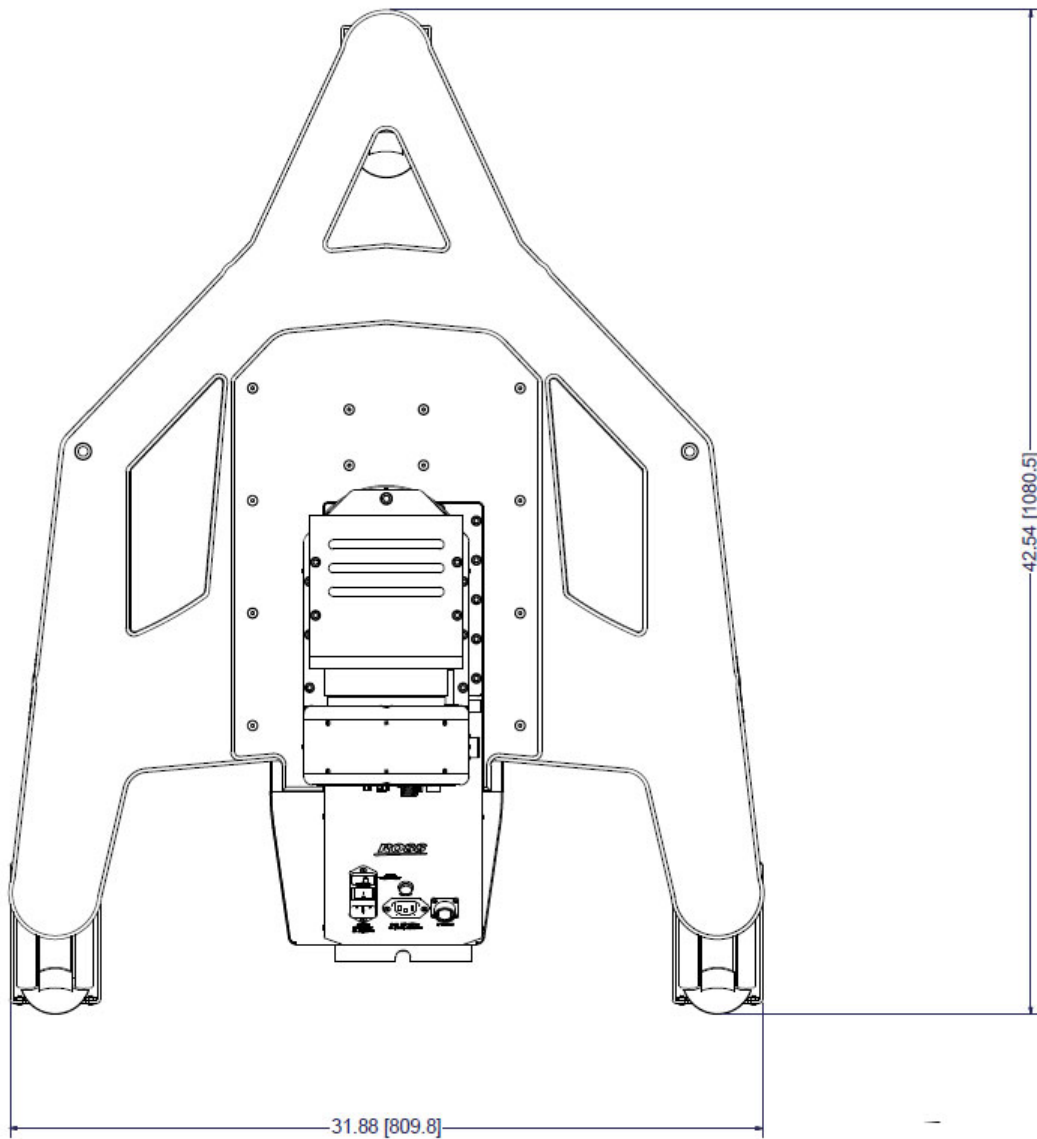
## Physical Dimensions

**Figure 1** shows side views of the BlackBird C2 pedestal with the two-stage lift column lowered (bottom), and raised (top). Measurements are shown in inches, followed by [millimeters].



**Figure 1** - BlackBird C2 Pedestal (side view)

**Figure 2** shows the top view of the BlackBird C2 pedestal. Measurements are shown in inches, followed by [millimeters].



**Figure 2** - BlackBird C2 Pedestal (top view)