

ARTIMO

Wheel and Belt Replacement

ROSS

Wheel and Belt Replacement Procedures

This procedure outlines the steps for changing the drive wheel belt, drive wheel, caster wheel belt, and caster wheels on the Artimo system. It includes required tools, safety precautions, and best practices to ensure proper installation and alignment. Follow these instructions carefully to maintain optimal performance and prevent damage to components.

CONTENTS

Required Tools and Materials	2
Removing the Front Cowling	2
Drive Wheel Belt Change	3
Preparing the Dolly.....	3
Removing the Old Belt.....	4
Installing the New Belt.....	5
Drive Wheel Change	6
Preparing for Wheel Removal.....	6
Removing the Old Wheel.....	7
Installing the New Wheel.....	8
Castor Wheel Belt Change	10
Preparing for Belt Removal.....	10
Removing the Old Belt.....	11
Installing the New Belt.....	12
Castor Wheel Change	13
Preparing for Wheel Removal.....	13
Removing the Old Wheel.....	14
Installing the New Wheel.....	15
Artimo Reassembly	16
Assembling Artimo Cowlings.....	16
GETTING HELP	16

Required Tools and Materials

Gather the following tools and materials before starting the procedure:

- Air Wedge shim
(capable of supporting at least 300 lbs and inflating up to 2 inches high)
- 22mm socket
- M4 hex key
- M5 hex key
- M6 hex key
- Loctite 243 (Blue Loctite®)

Removing the Front Cowling

To access internal components, follow these steps to remove the front dolly cowling:

1. Power off the Artimo unit.
2. Unscrew the 4 knurled knobs,
3. Partially pull the front dolly cowling away and disconnect the bumper cable.
Note: The front dolly cowling has a handle.
4. Once the bumper cable is disconnected, separate the front dolly cover from the unit.
5. Disconnect the front dolly bumper cable.
The connector is non-latching and just requires a good tug to separate.

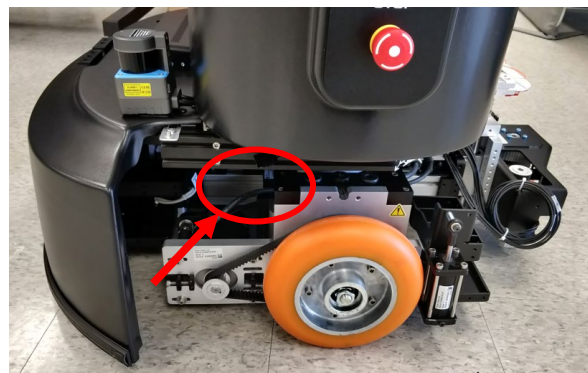

6. Place the front dolly cowling aside in a safe space.

Drive Wheel Belt Change

To replace the drive wheel belt, follow these steps to ensure proper alignment, tension, and installation.

Preparing the Dolly

Before removing the belt, position the dolly and lift it for access by completing the following:

1. Unpack and inspect the new belt.
Contact Ross Technical Support if you have concerns with the belt.
2. Rotate the front and back caster wheels by hand and align them to be in the same direction as the drive wheels.
Note: This will allow the dolly to move forward and backward.
3. Rotate the lift with the rear cowling.
4. Position the rear cowling opposite the wheel being worked on.
5. Place the air wedge under the dolly frame near the drive wheel.
6. Inflate the air wedge until the wheel is at least 6mm ($\frac{1}{4}$ inch) off the floor.

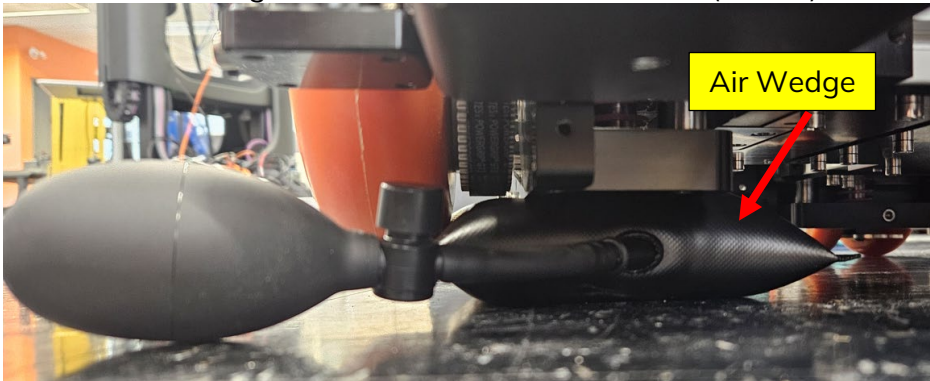

IMPORTANT: You should be able to slide the M6 hex key under the wheel once the wheel is off the ground at the minimum height.

Removing the Old Belt

Loosen the motor mount and reduce belt tension before removing the old belt by completing the following:

1. Loosen the four screws holding the motor in place with a 4mm hex key. Do not remove screws from the motor mount.

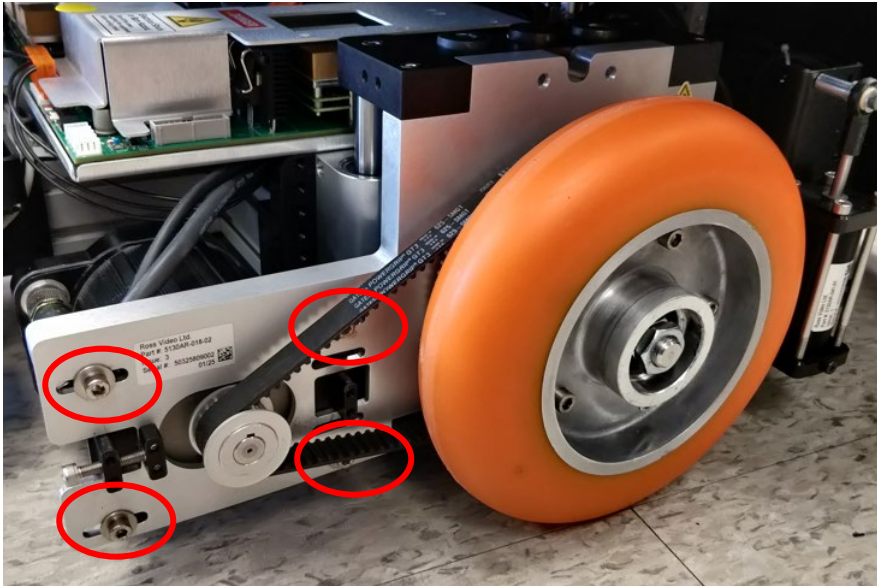

2. **Optional:** Mark the tension bracket position using a pen, tape, or other marking tool to aid in reinstallation.

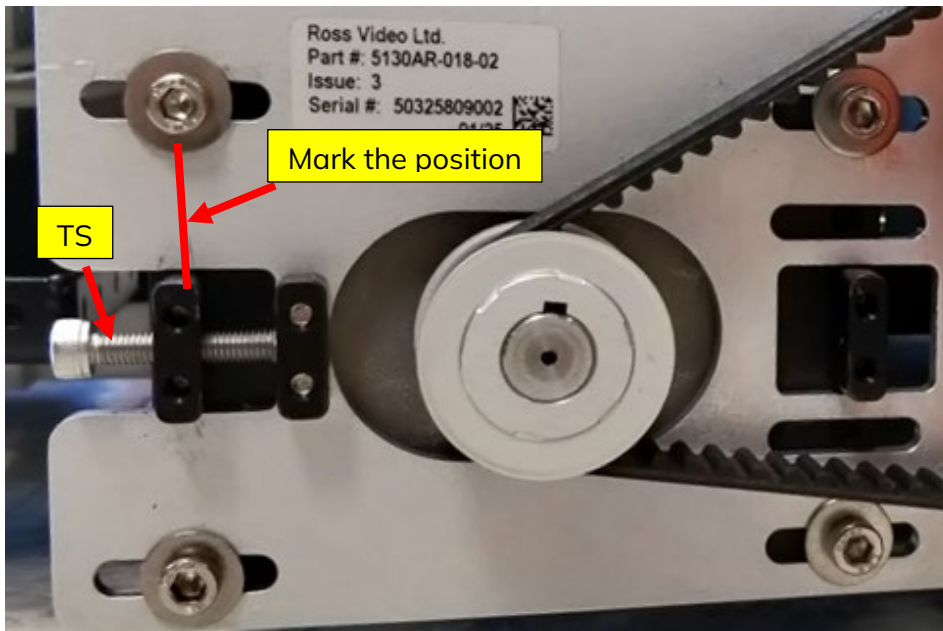

3. Loosen the M5 screw (TS) with a 4mm hex key to reduce belt tension.

4. Push the motor towards the wheel to release belt tension.
5. Remove the belt from the motor pulley and slip it over the wheel.

Installing the New Belt

Fit the new belt onto the pulleys and ensure correct engagement by completing the following:

1. Slip the new belt over the wheel and motor pulley.
2. Pull the motor pulley away from the drive wheel and confirm that the belt teeth are engaging with the motor and wheel pulley.
3. Drive the tensioning screw (TS) with a 4mm hex key to apply the belt tension. If applicable, align the post with the mark placed earlier.
Note: Belt tension should be between 183Hz and 193Hz. This can be checked with a belt tension meter.
4. Remove mark applied during **Step 2 of Removing the Old Belt** if applicable.
5. Tighten the 4 motor mount screws with a 4mm hex key. Tighten the two screws closest to the wheel first, then tighten the other two screws.
6. Spin wheel to confirm that the belt is properly installed.
7. Deflate the air wedge to lower the wheel back onto the ground.

Tip: Use an Allen Key to press the air release button. This allows one to keep hands away from under the dolly chassis.

Drive Wheel Change

Follow these steps to replace the drive wheel, ensuring proper alignment and secure installation.

Preparing for Wheel Removal

Before removing the old wheel, position the dolly and lift it for access by completing the following:

1. Unpack and inspect the new wheel.
Note: The wheel comes with a new bearing.
Contact Ross Technical support if there are concerns with the wheel.
2. Rotate the front and back caster wheels by hand and align them to be in the same direction as the drive wheels.
This will allow the dolly to move forward and backward.
3. Rotate the lift with the rear cowling attached. Position the rear cowling to be opposite the wheel being worked on.
4. Place the air wedge under the dolly frame near the drive wheel being replaced.
5. Inflate the air wedge until the wheel is at least 6mm ($\frac{1}{4}$ inch) off the floor.
Note: You should be able to slide the M6 hex key under the wheel once the wheel is off the ground at the minimum height.

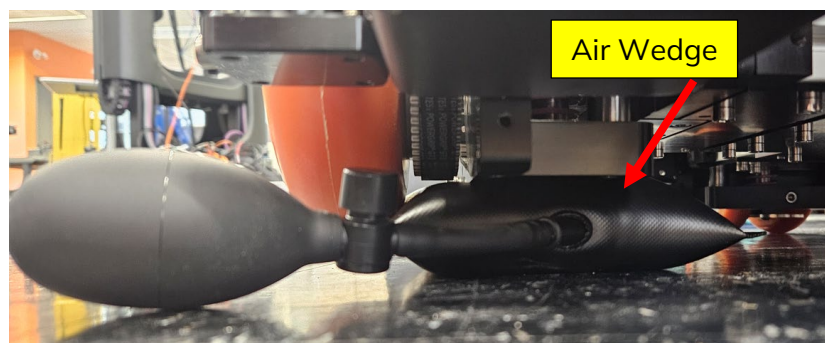

Removing the Old Wheel

Disassemble the fasteners and components to remove the wheel by completing the following:

1. Hold the frame steady and remove the two nuts and washer in the center hub holding the wheel in place with the 22mm socket.

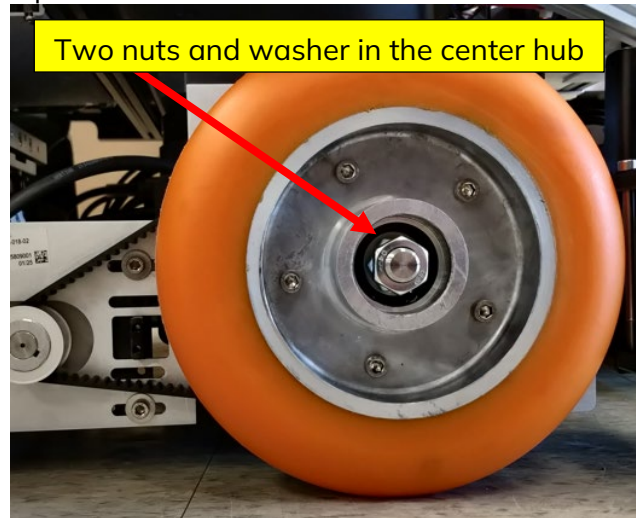

2. Remove the five M5 screws holding the wheel in place with a 4mm hex key.

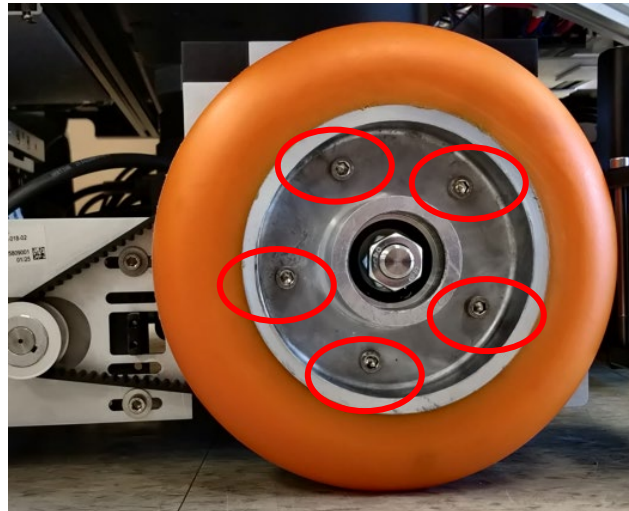

3. Remove the wheel, two bearings and the spacer from the shaft.

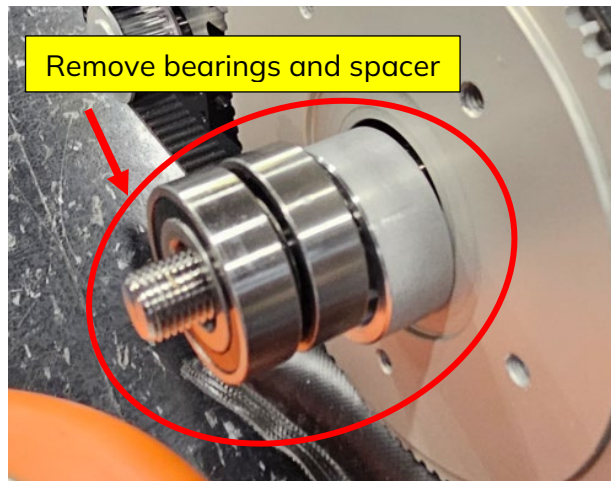

4. Set aside the old wheel and bearings. These can be discarded once the new wheel and bearings have been installed
5. Inspect the old spacer to ensure that it is not damaged.

Installing the New Wheel

Install the new wheel and bearings, ensuring correct alignment by completing the following:

1. Match the two new bearings.
Note: When matched, the marking on the side of the bearings should form a "V" or arrow head.
2. Insert the match bearing set into the hub with arrow facing into the hub well.
Tip: Place the first bearing in the hub and use the spacer to help guide the bearing into place. Pull the spacer out and repeat the steps for the second bearing.



3. Insert the spacer into the wheel hub and ensure that it sits flush with the hub.



4. Assemble the new wheel with the two bearings and spacer in the hub onto the shaft.
5. Add the washer and secure the first nut.
Tighten the nut in place with a 22mm socket.
Note: The nut torque should be 50 in-lbs
6. Thread the second nut onto the shaft.
7. Tighten the second nut in place with a 22mm socket.
Caution: Ensure the socket does not engage the first nut while tightening the second nut.
8. Apply Loctite 243 to the five M5 screws and secure the screws into the wheel hub using a 4mm hex key.
Note: Spin the wheel to help engage the five M5 screws through the wheel to the wheel pulley.
9. Seat the screws onto the wheel using a 4mm hex key.
Tip: Rocking the wheel back and forth will help reduce any resistance to threading in the screws.
10. Lower the dolly by deflating the air wedge and remove the air wedge from under the dolly.
Tip: Use an Allen Key to press the air release button. This allows one to keep hands away from under the dolly chassis
11. Once the dolly is lowered, tighten the five M5 screws (using a 4mm hex key) to 40 in-lbs using a start pattern.
12. Rotate the wheel and inspect the gap.
Inspect the wheel to confirm that it is on properly by inspecting the gap between the wheel and wheel pulley. Ensure the gap is uniform (as shown below).



Castor Wheel Belt Change

Follow these steps to replace the castor wheel belt, ensuring proper installation and correct belt tension.

Preparing for Belt Removal

Before removing the old belt, align the dolly, position the lift, and raise the castor wheel for access by completing the following:

1. Unpack and inspect the new belt.
Contact Ross Technical support if there are concerns with the belt.
2. Review belt changing videos.
3. Rotate the front and back castor wheels by hand and align them to be in the same direction as the drive wheels.
This will allow the dolly to move forward and backward.
4. Rotate the lift to with the rear cowling. Position the rear cowling to be opposite the wheel being worked on.
5. Place the air wedge under the dolly frame near the castor wheel being changed.
6. Inflate the air wedge until the wheel is at least 6mm ($\frac{1}{4}$ inch) off the floor.
Note: You should be able to slide the M6 hex key under the wheel once the wheel is off the ground at the minimum height.

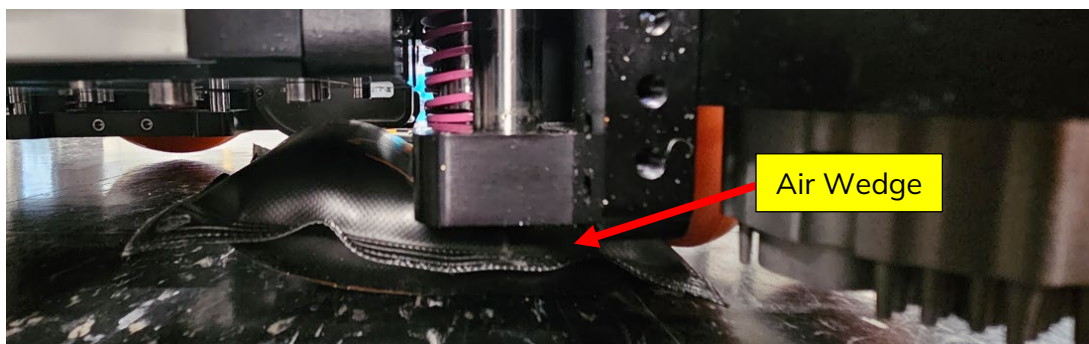

Removing the Old Belt

Loosen the motor mount and remove the belt from the wheel assembly and pulleys by completing the following:

1. Loosen the 4 mounting screws holding the motor in place using a 4mm hex key. Do not remove screws from the motor mount.

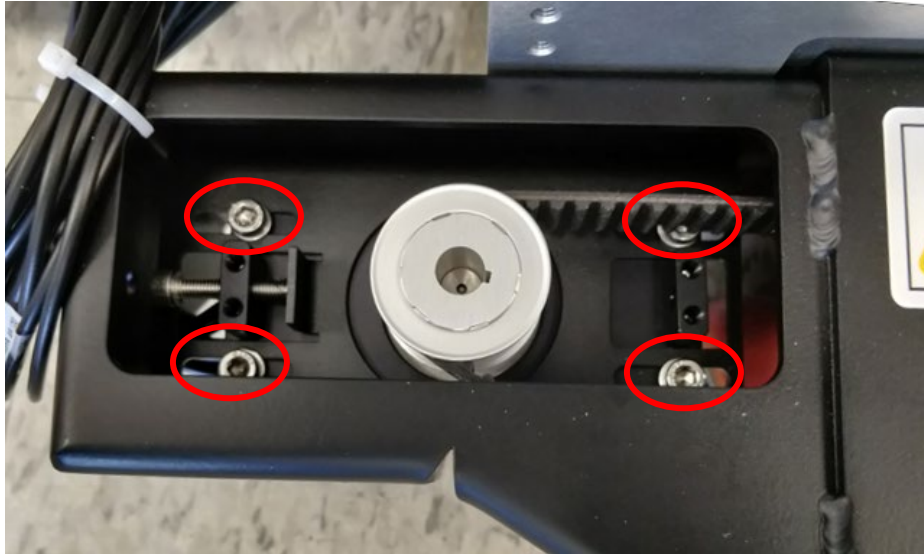

2. **Optional:** Place a mark (using a pen, tape or other marking tool) to indicate the tension bracket position. This will help when applying tension on the new belt.

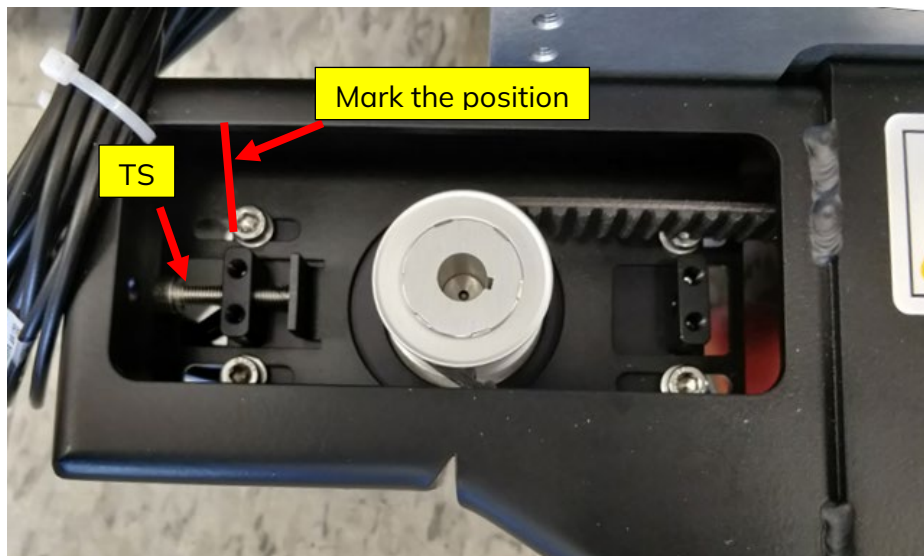

3. Loosen screw (TS) to loosen the belt tension using a 4mm hex key.

- Remove the four M5 screws (using a 4mm hex key) holding the caster wheel assembly in place to assist with removing the belt.
Note: Disassembling the caster wheel assembly from the bracket will provide more space between the wheel assembly and homing sensor for belt removal.



- Remove the belt by slipping it off the motor pulley and push the belt loop towards to the wheel assembly.
- Slide the wheel assembly towards the motor pulley and grasp the belt in the wheel compartment.
- Lower the belt down to the floor and peel it off the wheel assembly.
CAUTION: The belt might get caught up on the sensor and might get caught up on the hook loop.
Tip: Use the wheels to help remove the belt from around the wheel assembly. Roll the belt under both caster wheels in the same direction as the wheels.

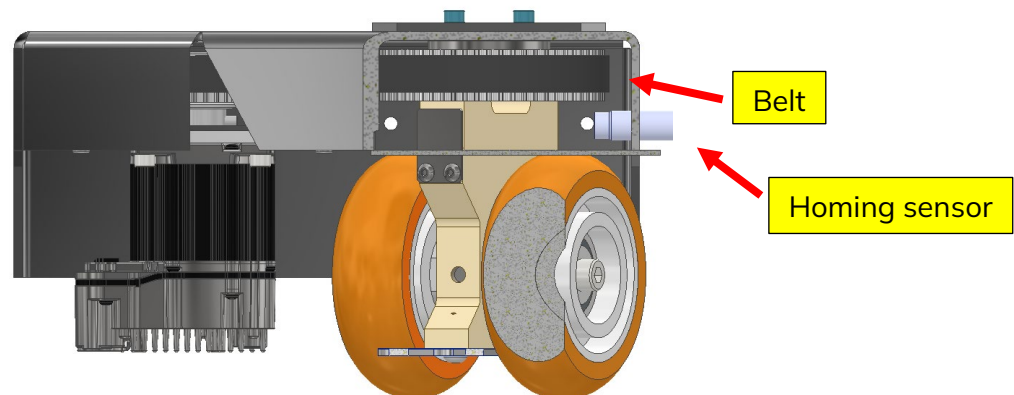

Installing the New Belt

Position the new belt around the wheel assembly and motor pulley, then reassemble and tension the system by completing the following:

- Slip the new belt around the wheel assembly and, while raising the belt, feed the belt toward the motor pulley.

2. Loop the belt over the motor pulley and ensure that the belt sits around the wheel pulley.
3. Screw the Dual Wheel Assembly back in place. Apply Loctite 243 to the screws.
4. Drive screw (TS) to apply the belt tension. Belt tension should be between 136Hz and 143Hz. This can be checked with a belt tension meter.
5. Remove mark if applicable
6. Tighten the 4 motor mount screws with a 4mm hex key.
7. Deflate the air wedge to lower the caster wheel back onto the ground.
Tip: Use an Allen Key to press the air release button. This allows one to keep hands away from under the dolly chassis.
8. Remove the air wedge from under the dolly.
9. Inspect the belt by rotating the motor pulley.

Castor Wheel Change

Follow these steps to replace the caster wheels, ensuring proper alignment and secure installation.

IMPORTANT: There are two caster wheels.
This procedure must be completed for each wheel.

Preparing for Wheel Removal

Position the dolly and lift it to provide access to the caster wheels by completing the following:

1. Unpack and inspect the new wheels.
The wheels come with new bearings.
Contact Ross Technical support if there are concerns with the wheels.
2. Rotate the front and back caster wheels by hand and align them to be in the same direction as the drive wheels.
This will allow the dolly to move forward and backward.
3. Rotate the lift to with the rear cowling. Position the rear cowling to be opposite the wheel being worked on.
4. Place the air wedge under the dolly frame near the wheel being replaced.
5. Inflate the air wedge until the wheel is at least 6mm ($\frac{1}{4}$ inch) off the floor.
Note: You should be able to slide the M6 hex key under the wheel once the wheel is off the ground at the minimum height.

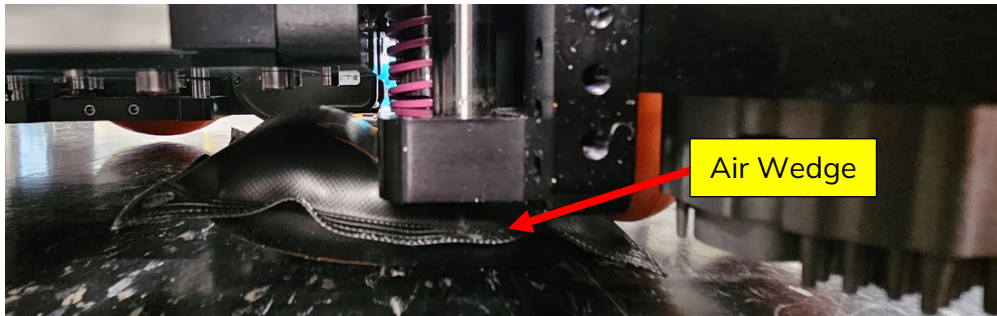

Removing the Old Wheel

Loosen the fasteners and remove the old caster wheel by completing the following:

1. Hold frame steady and remove the M8 screw holding the wheel in place with a 6mm hex key.

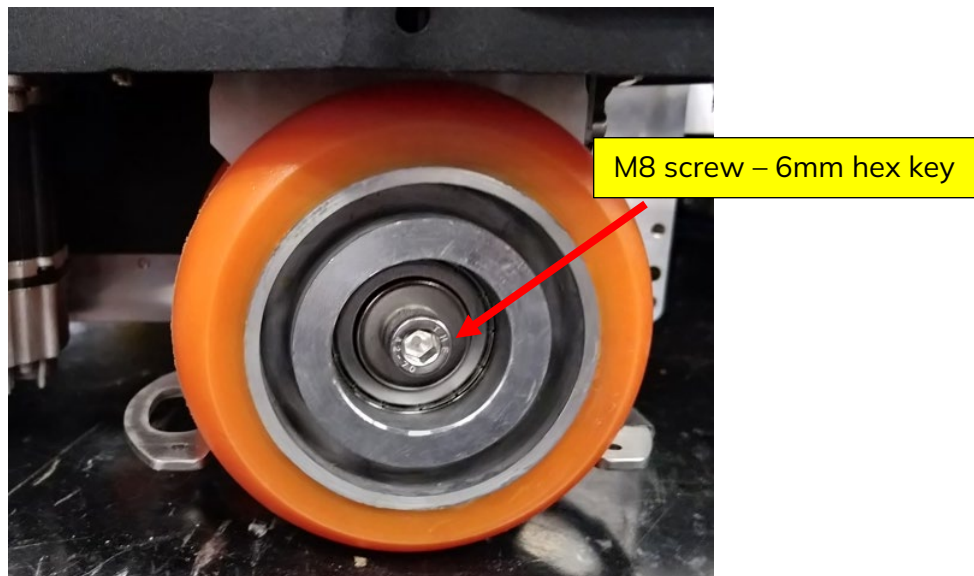

2. Remove the M8 screw and washer and set aside
3. Remove the wheel from the shaft. The bearing is secured in the wheel and comes off with the wheel

Installing the New Wheel

Attach the new wheel and secure all fasteners wheels by completing the following:

1. Install the new wheel onto the shaft with the retaining ring clip sitting closest to the center.

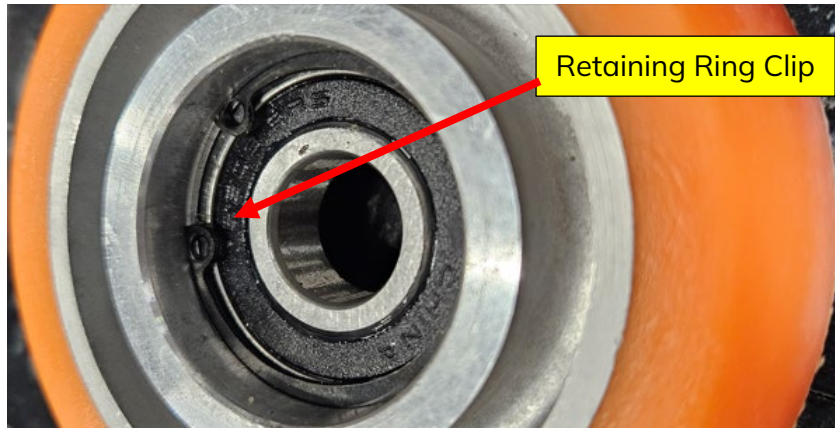

2. Place the washer on the M8 screw and apply Loctite 243 to the screw. Using a 6mm hex key, screw the M8 screw and washer assembly back on the shaft to hold the wheel in place.
3. Inspect the wheel by rotating the wheel on the shaft.
4. Repeat the steps in this procedure again for the other castor wheel.
5. Deflate the air wedge to lower the caster wheel back onto the ground.
Tip: Use an Allen Key to press the air release button. This allows one to keep hands away from under the dolly chassis.
6. Remove the air wedge from under the dolly.
7. Perform a final tightening of the M8 screws for both caster wheels using a 6mm hex key.

Artimo Reassembly

After completing maintenance, follow these steps to reassemble the dolly cowlings and restore normal operation.

Assembling Artimo Cowlings

1. After the maintenance is complete, check that the air wedge is removed, and the dolly rolls smoothly.
2. Reconnect the bumper strip connector.



3. Reinstall the dolly cover and secure the 4 knurled knobs
4. Turn the power back on.

GETTING HELP

- Product's Online Help system opens in your default web browser.
- Our 24-hour hotline service provides access to technical expertise around the clock. After-sales service and technical support is provided directly by Ross Video personnel.
- During business hours (Eastern Standard Time), technical support personnel are available by telephone.
- After hours and on weekends, emergency technical support is available. A telephone-answering device will provide the names and phone numbers of technical support and field service personnel who are on call. These people are available to react to any problem and to do whatever is necessary to ensure customer satisfaction. For serious issue which need urgent attention and tracking, please ensure you are given a ticket number and refer to this in future communications.
 - **Technical Support: (+1) 613-652-4886**
 - **After Hours Emergency: (+1) 613-349-0006**