

## Grass Valley Maverik Switcher

### Cable Connections

In an OverDrive system, a Grass Valley Maverik switcher connects to the OverDrive Server through a Caprica Server.

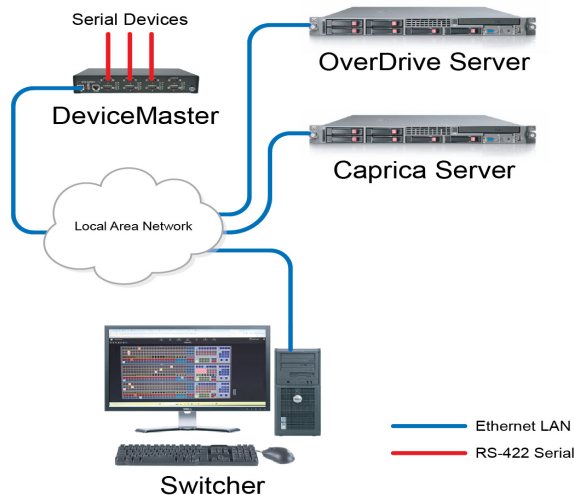

Grass Valley Maverik Switcher Cable Connections

### Switcher Device Port Configuration Settings

Use the following procedure to configure a switcher device for your Grass Valley Maverik switcher on the Caprica Server:

1. Use the current version of **DashBoard** software to connect to your **Caprica Server**.
2. In the **DashBoard Tree View**, double-click the **Port Configuration** node of your Caprica Server.
3. In the **Port Configuration Summary** table, double-click **SWITCHER1** in the **Port** column.
4. In the **Configure SWITCHER1** panel, click **Switcher**.
5. Click **Maverik**.
6. Click **Network Settings**.
7. In the **URL** box, enter the URL of your Grass Valley Maverik switcher.
8. In the **API Key** box, enter the API key for your Grass Valley Maverik switcher.
9. When you want Caprica to use a self signed certificate for HTTPs access to your Grass Valley Maverik switcher, select the **Permit Self Signed Cert** check box.

10. Click **Device Settings**.
11. Use the **Max EMEMs** box to enter or select the maximum number of electronic memories that OverDrive can access on your Grass Valley Maverik switcher.
12. Click **Black Source** to select the source on your Grass Valley Maverik switcher to use as black.
13. Use the **MemRecallDelay** box to enter or select the number of fields to wait for memory recalls to complete.
14. Use the **Transition Delay** box to enter or select the number of fields to wait for transitions to complete.
15. Use the **Max Inputs** box to enter or select the maximum number of inputs that OverDrive can access on your Grass Valley Maverik switcher.
16. Use the **Max Stills** box to enter or select the maximum number of stills that OverDrive can access on your Grass Valley Maverik switcher.
17. Use the **Max MEX** box to enter or select the maximum number of MEs that OverDrive can access on your Grass Valley Maverik switcher.
18. Click **Video Format** to select the video format set on your Grass Valley Maverik switcher.
19. Click **Apply Changes** to save the switcher settings.
20. Click **Done** to close the Configure SWITCHER1 panel.

### For More Information on...

- configuring a Grass Valley Maverik switcher for OverDrive, refer to the *Caprica User Guide*.

### Compatibility

- When the Shift button is pressed on the Grass Valley Maverik switcher while Caprica and OverDrive are connected, the switcher alters the input mapping that it provides to Caprica. OverDrive then receives incorrect crosspoints from Caprica.
- OverDrive can select stills as a crosspoint, but you must use macros on the Grass Valley Maverik switcher to control the content of stills.

Switcher	Version
Grass Valley Maverik	Latest

Automation	Version
OverDrive	23.2
Caprica Server	9.13.0

## Contacting Technical Support

Technical Support is staffed by a team of experienced specialists ready to assist you with any question or technical issue.

Ross Video has technical support specialists strategically located around the globe to ensure a prompt response to technical inquiries. Our primary technical support center is located in Ottawa, Ontario, Canada. In addition, we have offices in The United Kingdom (London), Australia (Sydney), and Singapore with satellite locations in New York City, The Netherlands, and China. As we expand our presence globally, we are constantly evaluating other key locations to have a local technical support specialist in order to better service our customers.

### North America

Our North America center located in Ottawa, Ontario, Canada and is open Monday to Friday 8:30 a.m. to 6:00 p.m. EST, with 24/7/365 on-call service after hours.

Our telephone number is: +1-613-686-1557

Toll free within North America: +1 833-859-0499

### EMEA

Our EMEA center is open Monday to Friday 8:30 a.m. to 5:00 p.m. GMT. After hours support is provided by our North America location.

Our telephone number is: +44 (0)1189502446

International toll free: +800 3540 3545

If the local support specialist is not available, your call will be transferred automatically to our North America center.

### Australia

Our Sydney, Australia office is located in Alexandria, NSW.

Our local support telephone number is: 1300 007 677

If the local support specialist is not available, your call will be transferred automatically to our North America center.

### Online

E-mail: [techsupport@rossvideo.com](mailto:techsupport@rossvideo.com)

Website: open a support request using the link <https://support.rossvideo.com/> to open a support request.

### Copyright

© 2014 - 2024 Ross Video Limited. Ross®, MLE®, OverDrive®, GlobalView®, RundownControl™, DirectControl™, DirectAudio™, DirectAUXaudio™, DirectCamera™, DirectServer™, QuickTurn™, RapidRestore™, SideShot™, SideSlide™, SideStick™, OverDrive Gateway™, LiveLink™, and any related marks are trademarks or registered trademarks of Ross Video Limited. All other trademarks are the property of their respective companies. PATENTS ISSUED and PENDING. All rights reserved. No part of this publication may be reproduced, stored in a retrieval system, or transmitted in any form or by any means, mechanical, photocopying, recording or otherwise, without the prior written permission of Ross Video. While every precaution has been taken in the preparation of this document, Ross Video assumes no responsibility for errors or omissions. Neither is any liability assumed for damages resulting from the use of the information contained herein.