

# FUJINON

2014 PRODUCT GUIDE

*Technology That Inspires...*



**FUJIFILM**  
Value from Innovation

*New*



*PL25-300*



*HA18x5.5*



*PL14-35*



*XA55x9.5*

*Technology That Inspires...*

**FUJIFILM**

**FUJINON**

Premier & Select ENG Features .....	2-3
Premier & Select ENG Options .....	4
ENG Wireless .....	4
HD & Studio/Field Features .....	5
PL Cabrio Lenses and Accessories .....	6-7
PL 4K+ Mount Cine Lenses .....	8
PF Lenses .....	9-11
Lenses for 1/3" HD Cameras .....	12
Lenses for 1/2" HD Cameras .....	13
Lenses for 2/3" HD Cameras .....	14-20
HDTV Studio Lenses .....	21
HDTV Field Lenses .....	22-24
HDTV Videoconferencing Lenses .....	25-26
Accessories .....	27-37
Notes .....	38-40

*Not every product shown in this guide is available worldwide.*

## Prefix

HA/XA/HAs	2/3" FORMAT (High Definition)
ZA	2/3" FORMAT (High Definition)
HAc	2/3" FORMAT (High Definition, Cine Compact Zoom)
HAe	2/3" FORMAT (High Definition, Cine Super Zoom)
HAeF	2/3" FORMAT (High Definition, Cine Super Prime)
HS/HSs/XS/ZS	1/2" FORMAT (High Definition)
HTs/XT	1/3" FORMAT (High Definition)
HK/ZK	PL MOUNT LENSES

## Suffix

E	Extender
MD	Motor Drive
RM	Manual Focus Servo Zoom
ZM	Manual Focus Servo Zoom with Quick Frame
RD	Full Servo (ENG Style)
ZD	Full Servo with Quick Frame
SM	Manual/Servo Module Interchangeable

## Example

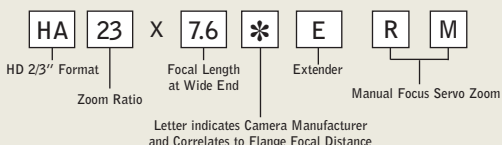

# PREMIER & SELECT ENG FEATURES



## DIGITAL GRIP

FUJINON has designed a new unique Digital Grip for **DIGI POWER** ENG Lenses.

The new Grip is enabled to enhance further lens operation performance.

## ERGONOMIC DESIGN

The beauty of our New Drive Grip is that it is focused on usability and comfort. We have implemented design input from the top camera users. It has a comfortable feel and the controls are naturally placed, a seamless interface.

## ENERGY-SAVING DESIGN

New Drive Grip achieves 50% drop in current draw compared to its predecessor as well as a significant reduction in operation noise.

## Super Slow Zoom

Smooth and natural zooming is possible at an extremely slow speed.

## DIGI POWER

In order to enhance the newest optical design technology, Fujinon has developed the digital servo control system **DIGI POWER** offering advanced performance of its zoom lenses. In addition to improved specification and performance the utilization of digital circuitry in our **DIGI POWER** product line has made many new features available that were virtually impossible in the past. **DIGI POWER** lenses provide for vastly improved accuracy and repeatability over previous designs and enable custom control parameters to be memorized for individual camera operator's preferences. An optional 16 bit processor for zoom, focus and iris is available for applications requiring a high degree of accuracy.

## QuickZoom

**QUICKZOOM** speed is 0.6 sec. / 0.7 sec.\* from end to end. **QUICKZOOM** provides a rapid zoom movement to the telephoto position to check focus by the simple push of a button. Releasing the button returns the lens to the previously selected zoom position. Furthermore, by setting the switch, **QUICKZOOM** can be performed remotely from zoom rate demand units.

\* 0.6 sec. : Studio and Field lens  
0.7 sec. : ENG/EFP lens



1 Frame your shot.



2 Press Q-Z button.



3 Lens automatically zooms in. Check focus and release Q-Z button.



4 Lens zooms back to original frame in full focus.

# PREMIER & SELECT ENG FEATURES

**QUICKZOOM** solves the problem of having to reframe a shot after checking focus. This exclusive feature is a standard component on all of DIGI POWER lenses.

Utilizing the **QUICKZOOM** function can be an extremely time saving and productive production tool, by allowing a quick check of focus after a framed shot has been established. Simply press the Q-Z button and the lens zooms in tight at maximum speed, check focus and release the Q-Z button. The lens zooms out to the pre-selected shot automatically. No more guess work as to what the framed shot was prior to checking focus.

## ZOOM MODE SELECT

A zoom mode switch provides the option to change the zoom response from "normal" to more sensitive on the wide or telephoto side. With the 3-zoom mode (10-zoom mode on ENG/EFP) the user can select the most suitable fine touch. These zoom mode settings are ideal when switching between productions such as drama and sports. The zoom torque adjust is available only on Quick Frame lenses.



## ZOOM LIMIT (available only on ZD drive)

The zoom limit function can be used in the servo operational mode. By using this function, the zoom movement toward both the wide side and the telephoto side can be limited. An override switch quickly returns the lens to normal mode.

Standard on: DIGI POWER Studio and Field lens,  
DIGIPOWER ENG / EFP lens



## AUTO-CRUIISING ZOOM

Pressing the C-Z button while zooming will fix the zoom speed at the existing rate. Pressing the seesaw switch a second time slightly will return the zoom speed to normal.

Standard on: DIGI POWER Studio and Field lens,  
DIGIPOWER ENG / EFP lens



## ZOOM MAXIMUM SPEED ADJUSTMENT

The maximum zooming speed obtained when pressing the seesaw switch to the end can be adjusted.

## Quickframe

### PRECISION SERVO/QUICK FRAME

The Precision Servo system provides precise control of zoom and focus by incorporating anti-backlash gearing. This is ideal for robotics and 3D applications. Sixteen bit encoders are available as an option. Quick Frame provides fast manual zooms without disengaging the manual zoom lock as in standard designs.

### VIRTUAL CONNECTOR WITH 16 BIT ENCODERS

FUJIFILM has developed the small and light encoder device in the drive unit. The high resolution 16 bit encoders in the DIGI POWER lens is now standard for more accurate positioning for virtual studio, robotic, and other applications.



16 Bit Encoders Now Standard

**Serial Digital Remote Control/PC Control** Remote control of zoom, focus and iris for **DIGI POWER** is possible via serial digital link.

## WIRELESS

The wireless WL-325A-A01L and A01C, transmitter and receiver, permits full zoom, focus, and iris control of Fujinon's Digi-Power lenses. All functions operate as smoothly and accurately as if connected by cable. The small, compact transmitter and receiver will function up to 100m distance from one another. When energized, the units automatically search for an unoccupied transmission channel. Operating on the 2.4GHz frequency, Fujinon's wireless system will never conflict with another device with a pairing feature.

### Specifications

Wireless Method	2.4 GHz
Size Receiver	69(W) x 28(H) x 115(L)
Transmitter	69(W) x 28(H) x 115(L)
Maximum Distance (outside)	100m
Power Receiver	Powered by lens
Transmitter	4 x AA Batteries or DC



Receiver WL-325A-A01L

Other features:

- Will not conflict with another device with pairing feature
- Searches for unoccupied channel automatically

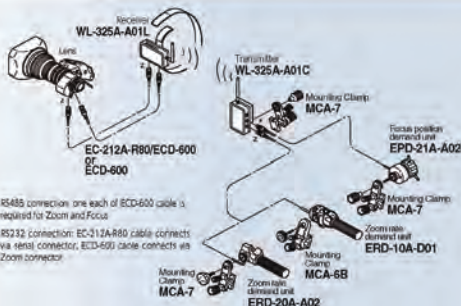

Transmitter WL-325A-A01C

# HD & STUDIO/FIELD FEATURES

## ONE SHOT PRESET

Zoom and focus can be preset and memorized in advance at a selected position. One touch of the switch during shooting will instantly return to the memorized position for time saving production.

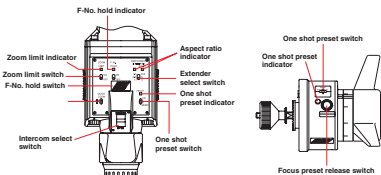

## ZOOM MODE SELECT

A zoom mode switch provides the option to change the zoom response from "normal" to more sensitive on the wide or telephoto side.

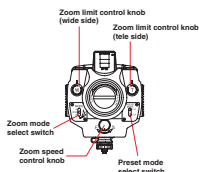

## ADVANCED BACK FOCUS: REMOTE MACRO AND FOCUS FADER

This system allows macro shooting as close as 0.05m (lens dependant) from the object. Focus faders are also possible at the wide side of the zoom range with the use of a simple remote control unit, adding to the production value.

Standard on some field and studio lenses (controller optional)

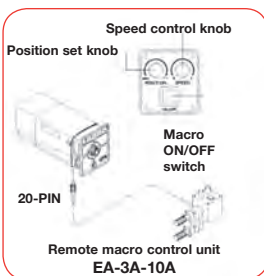

## AUTOMATIC COMPENSATION OF FOCUS BREATHING

This compensation mechanism enables the image size to remain constant when focusing by synchronizing the zoom movement to the focus movement, thus reducing image size change when focusing.

## F.I.N.D. SYSTEM

### F.I.N.D. SYSTEM

Fujinon's self-diagnostic system provides immediate analysis of the lens electronic systems. All DIGI POWER lenses are FIND capable. Installing the optional F.I.N.D. software for DIGI POWER in your PC allows a graphical user interface for lens history and diagnostic functions.

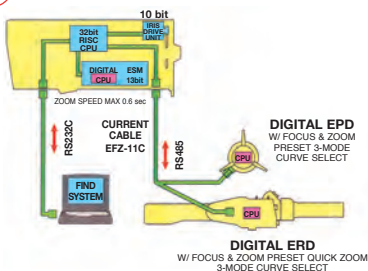

## Virtual Connector

An interface connector which provides an output of lens positional data is conveniently located on Fujinon's newest EFP and Studio lenses for interface with virtual advertising and statistical display systems.



# FUJINON *PREMIER PL* SERIES

The NEW Cabrio lenses present a breakthrough design in PL lenses. Cabrio lenses are designed to be the most versatile. The removable ENG style digital drive has focus, iris and zoom motors which allows for dynamic hand-held and documentary style shooting. Fujinon zoom & focus controllers, as well as cine industry standard wired or wireless controllers, can be connected. The 16 bit digital servo can be removed by means of 4 screws. To reattach to the lens, a newly developed self-aligning system is employed for easy and accurate calibration. The lens will accept standard 0.8 geared cine accessories. Power to the lens is through an external connector or the hot shoe. Lens data output is provided.

## *Premier PL Cabrio*



Unique detachable 16 bit digital drive. Can easily be reattached with 4 screws. With the digital auto-aligning system, it will be quickly and accurately calibrated.

### Breakthrough Design, Unparalleled Flexibility!



Digital servo interface connector. Barrel markings are luminous for visibility in dark shooting situations. Distance markings are available in feet or meters.



Hot shoe interface, pins shown on rear mount.



Interface on the digital servo allows for control using industry standard cinema controls as well as Fujinon wired and wireless units.

## *Cabrio*

**19 - 90 mm**  
**85 - 300 mm**



LENS (Focal Length)	19-90 mm	85-300 mm
Model Number	ZK4.7x19	ZK3.5x85
Zoom Ratio	4.7x	3.5x
Focal Length T-No.	T2.9 19 - 90 mm	T2.9 85-218mm T4.0 300mm
Iris Range	T2.9 - T22	T2.9 - T22
Close Focus Limit	0.85 m 2.79'	1.2 m 3.94'
Application	35 mm Film and Digital Cinema Camera	35 mm Film and Digital Cinema Camera
Format Cover	S35+ (31.5 ø)	S35+ (31.5 ø)
Mount	PL Mount	PL Mount
Angular Field of View	19 mm 71° 41' x 44° 14'	85 mm 18° 21' x 10° 23'
16:9 Aspect Ratio	90 mm 17° 20' x 9° 48'	300 mm 5° 14' x 2° 57'
Object Dimensions at Close Focus	19 mm 915 x 515 mm	85 mm 274 x 154 mm
16:9 Aspect Ratio	90 mm 193 x 109 mm	300 mm 79 x 44 mm
Dia ø x Length	ø 114 x 226 mm	ø 114 x 249 mm
Weight	2.85 kg w/ servo - 2.45 kg w/o	3.0 kg w/ servo - 2.6kg w/o
Features	Detachable, auto-centering servo drive*, Flange focal distance adjustment, Macro, LDS and i/Tech Data compatible** *Optional Detachable servo for PL 25-300 available Mid-2014 **Metadata only available with drive fitted	

# CABRIO LENSES ACCESSORIES

*Cabrio*



**PL25-300**



**PL14-35**

**HS-304A-114 LENS HOOD\***

**HA-304B-114 LENS HOOD\*\***

Fits on front of lens barrel.

Accepts 127mm filters.

\* PL i9-90 and PL85-300

\*\* PL14-35

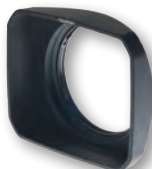

**K-127PTMC-MC127MM**

**(fits in hood)**

127mm Protection Filter.

Fits in optional lens hood.

**CABLES**

Model	20 PIN CABRIO LENS to...	CAMERA TYPE
SA-206M-1R2-US	12P CAMERA	SONY F65, F35
SA-206K-1R2-US	4P XLR POWER	RED ONE, RED EPIC, CANON C300, EARLY ALEXA, ETC
SA-206K-1R2P-US	P-Tap	RED ONE, RED EPIC, CANON C300, EARLY ALEXA, ETC
SA-206D-005	9P D Sub SERIAL	
SA-206R-1R16-US	Y Cable ** 20P PRESTON FIZ CABLE and 4P XLR PWR	RED ONE, RED EPIC, CANON C300, EARLY ALEXA, ETC
SA-206R-1R16P-US	Y Cable ** 20P PRESTON FIZ CABLE and P-TAP PWR	RED ONE, RED EPIC, CANON C300, EARLY ALEXA, ETC
** Required: Preston supplied "Fujinon Interface Cable"		

*Cabrio*

**14 - 35 mm**  
**25 - 300 mm**



LENS (Focal Length)	14-35 mm	25-300 mm
Model Number	ZK2.5x14	ZK12x25
Zoom Ratio	2.5x	12x
Focal Length T-No.	T2.9 14 - 35 mm	T3.5 25-273 mm T3.85 300 mm
Iris Range	T2.9 - T22	T3.5 - T22
Close Focus Limit	0.6 m 2.0'	1.2 m 3.94'
Application	35 mm Film and Digital Cinema Camera	35 mm Film and Digital Cinema Camera
Format Cover	S35+ (31.5 ø)	S35+ (31.5 ø)
Mount	PL Mount	PL Mount
Angular Field of View	14 mm 88° 52' x 57° 45'	25mm 57° 32' x 34°19'
16:9 Aspect Ratio	35 mm 42° 49' x 24° 53'	300 mm 5° 14' x 2° 57'
Object Dimensions at Close Focus	14 mm 701 x 394 mm	25 mm 937 x 527 mm
16:9 Aspect Ratio	35 mm 193 x 109 mm	300 mm 77 x 43 mm
Dia ø x Length	ø 114 x 231 mm	ø 136 x 401 mm
Weight	2.9 kg w/ servo - 2.4 kg w/o	8.9 kg
Features	Detachable, auto-centering servo drive*, Flange focal distance adjustment, Macro, LDS and i/Tech Data compatible** *Optional Detachable servo for PL 25-300 available Mid-2014 **Metadata only available with drive fitted	

# FUJINON *PREMIER PL* SERIES

## FOR FILM AND DIGITAL CINEMATOGRAPHY

Designed for current and emerging digital cinema motion picture and 35mm format film cameras, Fujinon's PL Series offer T-stop, focal range and optical performance previously unavailable in a family of PL zooms. With workable size, industry-inspired functionality and focal range from 14.5 mm to 400 mm, these zooms provide top performance and cost efficiency.

### Premier PL 4K+

#### Line Up

	WIDE							
Angular Field of View	79°	67°	53°	29°	18°	16°	7.4°	3.2°
Focal Length (mm)	14.5	18	24	45	75	85	180	400
	2/3"	5/8	7/2	9/6	18	30	34	72
HK3.1x14.5	14.5—45mm							
HK4.7x18			18—85mm					
HK7.5x24					24—180mm			
HK5.3x75							75—400mm	

### 14.5 - 45 mm (HK3.1x14.5) 18 - 85 mm (HK4.7x18)



LENS (Focal Length)	14.5 - 45 mm	18 - 85 mm
Model Number	HK3.1x14.5	HK4.7x18
Zoom Ratio	3.1x	4.7x
Focal Length	T2.0 14.5 - 45 mm	T2.0 18 - 85 mm
T-No.		
Iris Range	T2.0 - T22	T2.0 - T22
Close Focus Limit	0.71 m 2.3'	0.82 m 2.7'
Application	35 mm Film and Digital Cinema Camera	35 mm Film and Digital Cinema Camera
Format Cover	S35 (Super 35 Film Format/24x13.5mm)	S35 (Super 35 Film Format/24x13.5mm)
Mount	PL Mount	PL Mount
Angular Field of View	14.5 mm 79° 13' x 49° 56'	18 mm 67° 23' x 41° 07'
16:9 Aspect Ratio	45 mm 29° 52' x 17° 04'	85 mm 16° 04' x 9° 05'
Object Dimensions at Close Focus	14.5 mm 693 x 390 mm	18 mm 656 x 369 mm
16:9 Aspect Ratio	45 mm 215 x 121 mm	85 mm 139x78 mm
Dia ø x Length	ø 136 x 310 mm	ø 136 x 352 mm
Weigh	6.5 kg / 14.3 lbs	7.0 kg / 15.2 lbs

### 24 - 180 mm (HK7.5x24) 75 - 400 mm (HK5.3x75)



LENS (Focal Length)	24 - 180mm	75 - 400mm
Model Number	HK7.5x24	HK5.3x75
Zoom Ratio	7.5x	5.3x
Focal Length	1:2.6 24 - 180 mm	T2.8 (75-270mm), T3.8 (400mm)
T-No.		75 - 400 mm
Iris Range	T2.6 - T22	T2.8 - T22
Close Focus Limit	1.24 m 4'	2.0 m 6.6'
Application	35 mm Film and Digital Cinema Camera	35 mm Film and Digital Cinema Camera
Format Cover	S35 (Super 35 Film Format/24x13.5mm)	S35 (Super 35 Film Format/24x13.5mm)
Mount	PL Mount	PL Mount
Angular Field of View	24 mm 53° 08' x 31° 25'	75 mm 18° 11' x 10° 17'
16:9 Aspect Ratio	180 mm 7° 38' x 4° 18'	400 mm 3° 26' x 1° 56'
Object Dimensions at Close Focus	24 mm 924 x 520 mm	75 mm 580 x 326 mm
16:9 Aspect Ratio	180 mm 119 x 67 mm	400 mm 113x64 mm
Dia ø x Length	ø 136 x 405 mm	ø 136 x 444 mm
Weight	8.9 kg / 19.6 lbs	9.7 kg / 20.0 lbs

# PRECISION FOCUS LENSES



## PF-BUILT-IN LENSES

Fujinon's Precision Focus Assist enables camera operators the ability to ensure fast accurate focusing of high definition images under varying conditions. The PF system is the first to incorporate Fujinon's patented system which utilizes a unique contrast method of achieving precise focus.

## FEATURES AND FUNCTIONS

### CONTRAST FOCUSING METHOD

The Precision Focus System adopts a contrast method that utilizes differences in optical path length. It can instantly focus the image without searching for focus and can maintain precise focus even when following moving objects.

CCD A and CCD B are built into the lens barrel to detect the focusing conditions and are positioned at equal distances before and after the camera image forming plane.

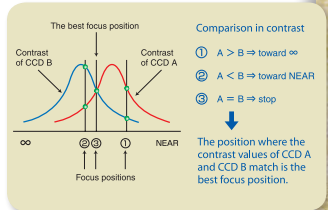

### COMPATIBLE WITH MOST 2/3" CAMERAS

The PF function is built into the lens and can be operational with the lens mounted on a 2/3" camera with no additional settings or optional devices. Camera software provides additional viewfinder information on some cameras dependant.

### FOCUS MODE SELECTION

PF is not an auto focus system, but a focus assist that precisely adjusts the lens for optimum focus. Focusing can be totally under the operators control as in a normal lens or may be operated in either momentary or continuous modes. A focus indicator in the viewfinder confirms best focus in all modes.

### FOCUS AREA SETTING

When the PF lens is mounted on a camera, a focus area is shown on the viewfinder. The size and the position of the focus area can be changed at the camera operator's discretion. This function allows greater flexibility in the selection of the focus area depending on the type of production.

Camera viewfinder image

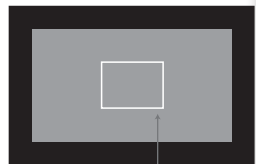

User selectable

### PRECISION TRACING SYSTEM

Facial Recognition or Precision Tracing System, Fujinon's Exclusive Proprietary Precision Tracing System technology works in conjunction with the Precision Focus Assist to recognize facial or object features and track these images within the pictures frame. A positional cursor box in the camera viewfinder is used to highlight the object to be memorized and the object is then tracked as its position changes within the frame. An optional touch screen monitor may also be used to select the desired object.

# PRECISION FOCUS LENSES

Fujinon's Precision Focus Assist enables camera operators the ability to ensure fast accurate focusing of high definition images under varying conditions. The PF system is the first to incorporate Fujinon's patented system which utilizes a unique contrast method of achieving precise focus.

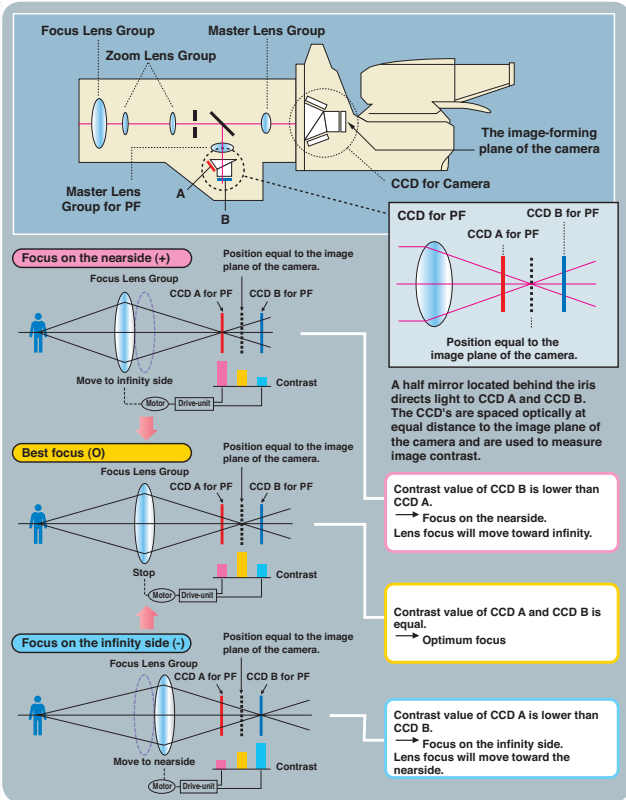

## PF CONTROLLER

The new focus controller for Fujinon's exclusive Precision Focus Assist provides operators with a simple to use yet powerful tool to maintain precise focus in the most demanding production situations. The familiar manual type focus controller has been adapted to encompass all of the precise servo features of the PF lens.



# PRECISION FOCUS LENSES

## HA13x4.5B RD HA22x7.3B RD



LENS	HA13x4.5BRD	HA22x7.3BRD
Zoom Ratio / Format	13X / 2/3"	22X / 2/3"
Focal Length	4.5 to 59 mm	7.3 to 161 mm
Maximum Relative Aperture	1:1.8 (4.5 ~ 41 mm)	1:1.9 (7.3 ~ 113 mm)
Maximum Photometric Aperture T-No.	T2.3 (4.5 ~ 41 mm) T3.3 (59 mm)	T2.3 (7.3 ~ 113 mm) T3.3 (161 mm)
Angular Field of View	4.5 mm 93° 38' x 61° 50'	7.3 mm 66° 36' x 40° 32'
16:9 Aspect Ratio	59 mm 9° 18' x 5° 14'	161 mm 3° 25' x 1° 55'
M.O.D. from Image Plane	0.60 m	1.19 m
M.O.D. from Front of Lens	0.30 m	0.85 m
Object Dimensions at M.O.D.	4.5 mm 757 x 425 mm 59 mm 55 x 31 mm	7.3 mm 1222 x 687 mm 161 mm 55 x 31 mm
Dia ø x Length (w/o Hood)	ø 95 x 256.1 mm	ø 110 x 300.2 mm
Weight (w/o Hood)	2.7 kg	3.9 kg
Features	Inner Focus, Zoom Limit	Inner Focus, Zoom Limit

## HA27x6.5BESM



Zoom Ratio / Format	27X / 2/3"	
Focal Length	6.5 ~ 180 mm (2X) 13 ~ 360 mm	
Maximum Relative Aperture	1:1.5 (6.5 ~ 123 mm)	
Maximum Photometric Aperture T-No.	T1.8 (6.5 ~ 123 mm) T2.6 (180 mm)	
Angular Field of View (Hor. x Vert. in °)	6.5 mm 72° 50' x 45° 02'	
16:9 Aspect Ratio	180 mm 3° 03' x 1° 43'	
	(2X) 13 mm 40° 30' x 23° 25'	
	360 mm 1° 32' x 0° 51'	
M.O.D. from Image Plane	1.23 m	
M.O.D. from Front of Lens	0.6 m	
Object Dimensions at M.O.D.	6.5 mm 1053 x 592 mm	
(Hor. x Vert. in mm)	180 mm 39 x 22 mm	
16:9 Aspect Ratio	(2X) 13 mm 527 x 296 mm	
Size (HxWxL)	360 mm 20 x 11 mm	
Weight (w/o Hood)	233 x 231 x 590 mm 21.8 kg	

## XA99x8.4BESM XA101x8.9BESM



LENS	XA99x8.4BESM	XA101x8.9BESM
Zoom Ratio / Format	99X / 2/3"	101X / 2/3"
Focal Length	8.4 ~ 832 mm (2X) 16.8 ~ 1664 mm	8.9 ~ 900 mm (2X) 17.8 ~ 1800 mm
Maximum Relative Aperture	1:1.7 (8.4 ~ 341 mm)	1:1.7 (8.9 ~ 291 mm)
Maximum Photometric Aperture T-No.	T1.85 (8.4 ~ 341 mm) T4.52 (832 mm)	T2.1 (8.9 ~ 291 mm) T5.8 (900 mm)
Angular Field of View (Hor. x Vert. in °)	8.4 mm 59° 26' x 35° 35'	8.9 mm 56° 38' x 33° 42'
16:9 Aspect Ratio	832 mm 0° 40' x 0° 22'	900 mm 0° 37' x 0° 21'
	(2X) 16.8 mm 31° 52' x 18° 14'	(2X) 17.8 mm 30° 09' x 17° 13'
	1664 mm 0° 20' x 0° 11'	1800 mm 0° 18' x 0° 10'
M.O.D. from Image Plane	2.9 m	3.65 m
M.O.D. from Front of Lens	3.55 m	2.9 m
Object Dimensions at M.O.D.	8.4 mm 2950 x 1658 mm	8.9 mm 2865 x 1610 mm
(Hor. x Vert. in mm)	832 mm 31 x 17 mm	900 mm 28 x 16 mm
16:9 Aspect Ratio	(2X) 16.8 mm 1538 x 864 mm	(2X) 17.8 mm 1433 x 805 mm
Size (HxWxL)	1664 mm 16 x 9 mm	1800 mm 14 x 8 mm
Weight (w/o Hood)	264 x 258 x 610 mm 23.5 kg	265 x 270 x 720 mm 25.5 kg

\* Some features require optional control or software.

# LENSES FOR 1/3" HD CAMERAS

The XT17sx4.5BRM and the XT20sx4.7BRM telephoto lens features minimized chromatic aberrations and improved corner resolution. Both lenses feature a newly designed digital servo.

The HTs18x4.2BRM and HTs18x4.2BERM high performance lenses feature superior resolution, high contrast and Fujinon's exclusive Digi Power servo with Quick Zoom, One Shot preset, Cruise Zoom, zoom limit and zoom speed adjust.

## PREMIER Series



### HTs18x4.2BERM

Zoom Ratio / Format	18X / 1/3"
Focal Length	4.2 to 76 mm (2X) 8.4 to 152 mm
Maximum Relative Aperture	1:1.4 (4.2 ~ 76 mm) (2X) 1:2.8 (152 mm)
Angular Field of View 16:9 Aspect Ratio	4.2 mm 63° 49' x 39° 35' 76 mm 3° 56' x 2° 13' (2X) 8.4 mm 34° 35' x 19° 51' 152 mm 1° 58' x 1° 6'
M.O.D. from Image Plane	0.84 m
M.O.D. from Front of Lens	0.60 m
Object Dimensions at M.O.D. 16:9 Aspect Ratio	4.2 mm 697 x 392 mm 76 mm 41 x 23 mm (2X) 8.2 mm 360 x 202 mm 152 mm 21 x 12 mm
Filter Size	ø 82 mm P=0.75
Dia ø x Length (w/o Hood)	ø 85 x 214.1 mm
Weight (w/o Hood)	1.58 kg
Features	Inner Focus / Quick Zoom / Zoom Limit / 16-Bit Encoders

## EXCEED Series

### XT17sx4.5BRM XT20sx4.7BRM



LENS	XT17sx4.5BRM	XT20sx4.7BRM
Zoom Ratio / Format	17X / 1/3"	20X / 1/3"
Focal Length	4.5 to 77 mm	4.7 to 94 mm
Maximum Relative Aperture	1:1.6 (4.5 ~ 77 mm)	1:1.4 (4.7 ~ 88 mm)
Aperture		1:1.5 (94 mm)
Angular Field of View 16:9 Aspect Ratio	4.5 mm 60° 19' x 36° 11' 77 mm 3° 53' x 2° 11'	4.7 mm 58° 11' x 34° 44' 94 mm 3° 11' x 1° 48'
M.O.D. from Image Plane	1.16 m	1.12 m
M.O.D. from Front of Lens	0.95 m	0.9 m
Object Dimensions at M.O.D. 16:9 Aspect Ratio	4.5 mm 999 x 562 mm 77 mm 60 x 34 mm	4.7 mm 901x506 mm 94 mm 47x26 mm
Filter Size	ø 82 mm P=0.75	ø 82 mm P=0.75
Dia ø x Length (w/o Hood)	ø 85 x 175.6 mm	ø 85 x 189.8 mm
Weight (w/o Hood)	1.28 kg	1.48 kg
Features	Inner Focus / Quick Zoom	Inner Focus / Quick Zoom

# LENSES FOR 1/2" HD CAMERAS

Fujinon offers a complete line of 1/2" lenses. From the Premier series HS16x4.6BERM that combines wide angle and a 16x zoom range, and the HS18x5.5BERM/BERD, both featuring integral 2x extender, and the HSs18x5.5BRM/BRD standard lens. The 1/2" Select and Exceed series provides the user with very high quality, economical lenses with Digi-Power servos, and unrivaled performance for News and Production applications. The Select series ZS17x5.5BERM w/ 2x extender, wide angle XS13x3.3BRM and economical XS178x5.5BRM, round out the line. All lenses utilize Fujinon's exclusive Digi-Power servo system for maximum versatility.

## SELECT Series

### XS13x3.3B RM



Zoom Ratio / Format	13X / 1/2"
Focal Length	3.3 to 43 mm
Maximum Relative Aperture	1:1.4 (3.3 ~ 32 mm) 1:1.9 (43 mm)
Angular Field of View	3.3 mm 93° 07' x 61° 25'
16:9 Aspect Ratio	43 mm 9° 16' x 5° 13'
M.O.D. from Image Plane	0.58 m
M.O.D. from Front of Lens	0.30 m
Object Dimensions at M.O.D. 16:9 Aspect Ratio	3.3 mm 752 x 423 mm 43 mm 54 x 30 mm
Filter Size	ø 127 mm P=0.75 (In Hood)
Dia ø x Length (w/o Hood)	ø 95 x 240.5 mm
Weight (w/o Hood)	1.93 kg
Features	Inner Focus / Quick Zoom

## SELECT Series

### ZS17x5.5BERM



Zoom Ratio / Format	17X / 1/2"
Focal Length	5.5 to 94 mm (2X) 11 to 188 mm
Maximum Relative Aperture	1:1.4 (5.5 ~ 77 mm) 1:1.7 (94 mm)
Angular Field of View	5.5 mm 64° 43' x 39° 14'
16:9 Aspect Ratio	94 mm 4° 15' x 2° 23'
	(2X) 11 mm 35° 09' x 20° 12'
	188 mm 2° 07' x 1° 12'
M.O.D. from Image Plane	0.84 m
M.O.D. from Front of Lens	0.6 m
Object Dimensions at M.O.D. 16:9	5.5 mm 692 x 389 mm 94 mm 42 x 24 mm
Filter Size	ø 82 mm P=0.75 (On Barrel)
Dia ø x Length (w/o Hood)	ø 85 x 206.6 mm
Weight (w/o Hood)	1.58 kg
Features	Inner Focus / Quick Zoom / Zoom Limit / 16 Bit Encoders

## EXCEED Series

### XS20sx6.3BRM



Zoom Ratio / Format	20X / 1/2"
Focal Length	6.3 to 126 mm
Maximum Relative Aperture	1:1.4 (6.3 ~ 88 mm) 1:2.0 (126 mm)
Angular Field of View	6.3 mm 57° 54' x 34° 34'
16:9 Aspect Ratio	126 mm 3° 10' x 1° 47'
M.O.D. from Image Plane	1.11 m
M.O.D. from Front of Lens	0.9 m
Object Dimensions at M.O.D. 16:9 Aspect Ratio	904 x 508 mm 47 x 26 mm
Filter Size	ø 82 mm P=0.75 (In Hood)
Dia ø x Length (w/o Hood)	ø 85 x 181.9 mm
Weight (w/o Hood)	1.4 kg
Features	Inner Focus / Quick Zoom / Zoom Limit

# LENSES FOR 2/3" HD CAMERAS

Fujinon's Premier Series lenses are designed to compliment and enhance the quality of the world's most advanced 1/2 and 2/3 inch HDTV cameras

The highest optical, mechanical, and electrical specifications are incorporated into every Premier lens, along with powerful features & functions. QuickZoom, CruiseZoom, One-shot Preset, as well as a multitude of Digi-Power control functions provide the operator with all the tools at hand to ensure a great shot! And now all of this is in an ergonomically redesigned and performance enhanced New Digital Drive Grip.

## PREMIER Series



### HA14x4.5BE RM/RD\*/ZD\*\*

Zoom Ratio / Format	14X / 2/3"	
Focal Length	4.5 to 63 mm	
	(2.2X)	9.9 to 138 mm
Maximum Relative Aperture	1:1.8 (4.5 ~ 41 mm)	
	(2.2X)	1:2.8 (63 mm)
Maximum Photometric Aperture T-No.	T2.0 (4.5 ~ 41 mm)	
		T2.9 (63 mm)
Angular Field of View	4.5 mm	93° 38' x 61° 50'
16:9 Aspect Ratio	63 mm	8° 42' x 4° 54'
	(2.2X)	9.9 mm 51° 41' x 30° 27'
		138 mm 3° 57' x 2° 13'
M.O.D. from Image Plane	0.59 m	
M.O.D. from Front of Lens	0.3 m	
Object Dimensions at M.O.D.	4.5 mm	743 x 418 mm
16:9 Aspect Ratio	63 mm	59 x 63 mm
	(2.2X)	9.9 mm 329 x 185 mm
		138 mm 24 x 13 mm
Filter Size	ø 127 mm P=0.75 (In Hood)	
Dia ø x Length (w/o Hood)	ø 95 mm x 238.5 mm	
Weight (w/o Hood)	2.08 kg (RM) / 2.14 kg (RD)* / 2.2 kg (ZD)**	
Options	16 Bit Encoders (ZD only) / Quick Frame	
Features	Inner Focus / Zoom Limit / Quick Zoom 16 Bit Encoders (RM / RD only)	

## PREMIER Series



### HA18x5.5BE RM/RD\*/ZD\*\*

Zoom Ratio / Format	18X / 2/3"	
Focal Length	5.5 to 100 mm	
	(2X)	11 to 200 mm
Maximum Relative Aperture	1:1.8 (5.5 ~ 62 mm)	
		1:2.9 (100 mm)
Maximum Photometric Aperture T-No.	T1.9 (5.5 ~ 62 mm)	
		T3.1 (100 mm)
Angular Field of View	5.5 mm	82° 10' x 52° 13'
16:9 Aspect Ratio	100 mm	5° 29' x 3° 05'
	(2X)	11 mm 47° 06' x 27° 32'
		200 mm 2° 45' x 1° 33'
M.O.D. from Image Plane	0.69 m	
M.O.D. from Front of Lens	0.4 m	
Object Dimensions at M.O.D.	5.5 mm	800 x 450 mm
16:9 Aspect Ratio	100 mm	44 x 25 mm
	(2X)	11 mm 395 x 222 mm
		200 mm 22 x 12 mm
Filter Size	ø 127 mm x 0.75 mm (In Hood Mounting Only)	
Dia ø x Length (w/o Hood)	ø 95 mm x 240.5 mm	
Weight (w/o Hood)	1.97 kg / 2.04 kg* / 2.10 kg**	
Options	16 Bit Encoders (ZD only) / Quick Frame	
Features	Inner Focus / Zoom Limit / Quick Zoom / Virtual Serial Com / PC / Macro / 16 Bit Encoders (RM / RD only)	

\*RD contain Servos for Zoom and Focus.

\*\*ZD contains Quick Frame / Precision Zoom Focus System.

# LENSES FOR 2/3" HD CAMERAS

## PREMIER Series

### HA18x7.6BE RM/RD\*/ZD\*\*



Zoom Ratio / Format	18X / 2/3"
Focal Length	7.6 to 137 mm (2X) 15.2 to 274 mm
Maximum Relative Aperture	1:1.8 (7.6 ~ 103 mm) 1:2.4 (137 mm)
Maximum Photometric Aperture T-No.	1:1.9 (7.6 ~ 105 mm) 1:2.6 (137 mm)
Angular Field of View 16:9 Aspect Ratio	7.6 mm 64° 30' x 39° 03' 137 mm 4° 01' x 2° 15' (2X) 15.2 mm 35° 01' x 20° 07' 274 mm 2° 00' x 1° 08'
M.O.D. from Image Plane	0.84 m
M.O.D. from Front of Lens	0.6 m
Object Dimensions at M.O.D. 16:9 Aspect Ratio	7.6 mm 696 x 392 mm 137 mm 41 x 23 mm (2X) 15.2 mm 362 x 204 mm 274 mm 21 x 12 mm
Filter Size	82 mm P=0.75 (On Barrel)
Dia ø x Length (w/o Hood)	85 x 204 mm
Weight (w/o Hood)	1.58 kg RM / 1.65 kg RD* / 1.7 kg ZD**
Options	16 Bit Encoders (ZD only) / Quick Frame
Features	Inner Focus / Zoom Limit / Quick Zoom / 16 Bit Encoders (RM / RD only)

## PREMIER Series

### HA19x7.4BE RM/RD\*/ZD\*\*



Zoom Ratio / Format	19X / 2/3"
Focal Length	7.4-141 mm (2.2X) 16.3-310 mm
Maximum Relative Aperture	1:1.8 (7.4 ~ 98 mm) 1:2.6 (141 mm)
Maximum Photometric Aperture T-No.	T1.9 (7.4 ~ 98 mm) T2.7 (141 mm)
Angular Field of View 16:9 Aspect Ratio	7.4 mm 65°53' x 40°01' 141 mm 3°54' x 2°11' (2.2X) 16.3 mm 32°49' x 18°48' 310 mm 1°46' x 1°00'
M.O.D. from Image Plane	0.85 m
M.O.D. from Front of Lens	0.55 m
Object Dimensions at M.O.D. 16:9 Aspect Ratio	7.4 mm 773 x 434 mm 42 mm 42 x 24 mm (2.2X) 16.3 mm 359 x 202 mm 310 mm 20 x 11 mm
Filter Size	ø 95 mm P=1 mm / ø 107 mm P= 1 mm (In Hood)
Dia ø x Length (w/o Hood)	ø 100 mm x 239.5 mm
Weight (w/o Hood)	2.21 kg (RM) / 2.28 kg (RD)* / 2.28 kg (ZD)**
Options	16 Bit Encoders (ZD only) / Quick Frame
Features	16 Bit Encoders (RM / RD only) / Inner Focus / Zoom Limit / Quick Zoom / 2.2 Ext. /

\*RD contain Servos for Zoom and Focus.

\*\*ZD contains Quick Frame / Precision Zoom Focus System.

# LENSES FOR 2/3" HD CAMERAS

## HA23x7.6BE RM/RD\*/ZD\*\*



Zoom Ratio / Format	23X / 2/3"	
Focal Length	7.6 to 175 mm	
	(2X)	15.2 to 350 mm
Maximum Relative Aperture	1:1.8 (7.6 ~ 122 mm)	
	1:2.65 (175 mm)	
Maximum Photometric Aperture T-No.	T1.9 (7.6 ~ 122 mm)	
	T2.8 (175 mm)	
Angular Field of View	7.6 mm	64° 30' x 39° 03'
16:9 Aspect Ratio	175 mm	3° 08' x 1° 46'
	(2X)	15.2 mm 35° 01' x 20° 07'
		350 mm 1° 34' x 0° 53'
M.O.D. from Image Plane	1.07m	
M.O.D. from Front of Lens	0.8m	
Object Dimensions	7.6 mm	915 x 514 mm
at M.O.D. 16:9 Aspect Ratio	175 mm	41 x 23 mm
	(2X)	15.2 mm 473 x 266 mm
		350 mm 21 x 12 mm
Filter Size	ø 95mm P=1 (On Barrel) / ø 107mm P=1 (In Hood)	
Dia ø x Length (w/o Hood)	ø 100 x 223.6 mm	
Weight (w/o Hood)	1.88 kg (RM) / 1.95 kg (RD) / 2.01 kg (ZD)**	
Options	16 Bit Encoders (ZD only) / Quick Frame	
Features	Inner Focus / Zoom Limit / Quick Zoom	
	16 Bit Encoders (RM / RD only)	

## HA25x11.5BERD\*



Zoom Ratio / Format	25X / 2/3"	
Focal Length	11.5 to 288 mm	
	(2X)	23 to 576 mm
Maximum Relative Aperture	1:2.0 (11.5 ~ 206 mm)	
	1:2.8 (288 mm)	
Maximum Photometric Aperture T-No.	T2.1 (11.5 ~ 206 mm)	
	T2.9 (288 mm)	
Angular Field of View	11.5 mm	45° 16' x 26° 23'
16:9 Aspect Ratio	288 mm	1° 54' x 1° 04'
	(2X)	23 mm 23° 33' x 13° 22'
		576 mm 0° 57' x 0° 32'
M.O.D. from Image Plane	2.51 m	
M.O.D. from Front of Lens	2.2 m	
Object Dimensions	11.5 mm	1740 x 978 mm
at M.O.D.	288 mm	70 x 39 mm
	(2X)	23 mm 870 x 489 mm
		576 mm 35 x 20 mm
Filter Size	ø 107 mm P=1 (On Barrel)	
	ø 127 m P=0.75 (In Hood)	
Dia ø x Length (w/o Hood)	ø 110 x 265 mm	
Weight (w/o Hood)	2.8 kg	
Features	Inner Focus / Quick Zoom / Inner Focus	

## HA25x16.5BERD\*



Zoom Ratio / Format	25X / 2/3"	
Focal Length	16.5 to 413 mm	
	(2X)	33 to 826 mm
Maximum Relative Aperture	1:2.8 (16.5 ~ 289mm)	
	1:4.0 (413 mm)	
Maximum Photometric Aperture T-No.	T2.9 (16.5 ~ 289 mm)	
	T4.2 (413 mm)	
Angular Field of View	16.5 mm	32° 25' x 18° 33'
16:9 Aspect Ratio	413 mm	1° 20' x 0° 45'
	(2X)	33 mm 16° 32' x 9° 20'
		826 mm 0° 40' x 0° 22'
M.O.D. from Image Plane	2.52 m	
M.O.D. from Front of Lens	2.2 m	
Object Dimensions	16.5 mm	1213 x 682 mm
at M.O.D.	413 mm	49 x 27 mm
	(2X)	33 mm 606 x 341 mm
		826 mm 24 x 14 mm
Filter Size	ø 107 mm P=1 (On Barrel)	
	ø 127m P=0.75 (In Hood)	
Dia ø x Length (w/o Hood)	ø 110 x 278 mm	
Weight (w/o Hood)	2.9 kg	
Features	Inner Focus / Quick Zoom / Inner Focus	

\*RD contain Servos for Zoom and Focus. \*\*ZD contains Quick Frame / Precision Zoom Focus System.

# LENSES FOR 2/3" HD CAMERAS

## HA42x9.7BERD

OS-TECH



Zoom Ratio / Format	42X / 2/3"
Focal Length	9.7 ~ 410 mm (2X) 19.4 ~ 820 mm
Maximum Relative Aperture	1:2.0 (9.7 ~ 225 mm) 1:3.7 (410 mm)
Maximum Photometric Aperture T-No.	T2.2 (9.7 ~ 225 mm) T4.0 (410 mm)
Angular Field of View 16:9 Aspect Ratio	9.7 mm 52° 37' x 31° 03' 410 mm 1° 20' x 0° 45' (2X) 19.4 mm 27° 46' x 15° 49' 820 mm 0° 40' x 0° 23'
M.O.D. from Image Plane	3.18 m
M.O.D. from Front of Lens	2.8 m
Object Dimensions at M.O.D.	9.7 mm 2619 x 1472 mm 410 mm 64 x 36 mm (2X) 19.4 mm 1339 x 753 mm 820 mm 33 x 19 mm
Filter Size	ø 127 mm P=0.75 (On Barrel)
Dia ø x Length (w/o Hood)	ø130 x 338.5 mm
Weight (w/o Hood)	5.3 kg
Options	Built In OS-TECH
Features	Inner Focus / Zoom Limit / Quick Zoom

## HA42x13.5BERD

OS-TECH



Zoom Ratio / Format	42X / 2/3"
Focal Length	13.5 ~ 570 mm (2X) 27 ~ 1140 mm
Maximum Relative Aperture	1:2.8 (13.5 ~ 307 mm) 1:5.2 (570 mm)
Maximum Photometric Aperture T-No.	T3.0 (13.5 ~ 307 mm) T5.6 (570 mm)
Angular Field of View 16:9 Aspect Ratio	13.5 mm 39° 07' x 22° 35' 570 mm 0° 58' x 0° 33' (2X) 27 mm 20° 08' x 11° 24' 1140 mm 0° 29' x 0° 16'
M.O.D. from Image Plane	3.2 m
M.O.D. from Front of Lens	2.8 m
Object Dimensions at M.O.D.	13.5 mm 1888 x 1061 mm 570 mm 45 x 25 mm (2X) 27 mm 944 x 530 mm 1140 mm 22 x 13 mm
Filter Size	ø 127 mm P=0.75 (On Barrel)
Dia ø x Length (w/o Hood)	ø130 x 358.5 mm
Weight (w/o Hood)	5.4 kg
Options	Built In OS-TECH
Features	Inner Focus / Zoom Limit / Quick Zoom

\*RD contain servos for zoom and focus.

## OS-TECH

The HA42x9.7 and HA42x13.5 are optionally equipped with Fujinon's built-in optical stabilization technology (OS-TECH). This feature optically compensates for image vibration as shown below.

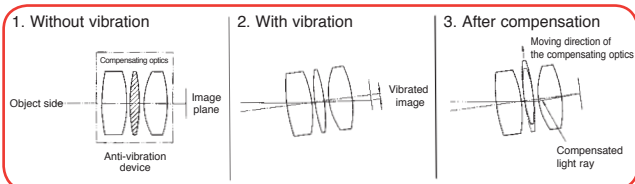

# LENSES FOR 2/3" HD CAMERAS

Fujinon's Select Series is designed to meet the performance needs of today's mid-range HD cameras. Fujinon worked closely with all major camera manufacturers to engineer true HD lenses that are designed specifically to enhance the performance quality of these cameras.

## SELECT Series



### ZA12x4.5B RM/RD\*

Zoom Ratio / Format	12X / 2/3"
Focal Length	4.5 to 54 mm
Maximum Relative Aperture	1:1.8 (4.5 ~ 41 mm)
Maximum Photometric Aperture T-No.	1:2.4 (54 mm)
Angular Field of View 16:9 Aspect Ratio	T1.9 (4.5 ~ 41 mm) T2.6 (54 mm)
M.O.D. from Image Plane	4.5 mm 93° 38' x 61° 50'
M.O.D. from Front of Lens	54 mm 10° 09' x 5° 43'
Object Dimensions at M.O.D. 16:9 Aspect Ratio	0.59 m
Filter Size	0.3 m
Dia ø x Length (w/o Hood)	4.5 mm 757 x 425 mm
Weight (w/o Hood)	54 mm 59 x 33 mm
Features	ø 127 mm P=0.75 (In Hood)
	ø 95 x 237.5 mm
	1.83 kg (RM) / 1.9 kg (RD/ZD)
	16 Bit Encoders (RM / RD only) / Inner Focus / Zoom Limit / Quick Zoom

## SELECT Series



### ZA12x4.5BE RM/RD\*

Zoom Ratio / Format	12X / 2/3"
Focal Length	4.5 to 54 mm (2X) 9 to 108 mm
Maximum Relative Aperture	1:1.8 (4.5 ~ 41 mm)
Maximum Photometric Aperture T-No.	1:2.4 (54 mm)
Angular Field of View 16:9 Aspect Ratio	T1.9 (4.5 ~ 41 mm) T2.6 (54 mm)
M.O.D. from Image Plane	4.5 mm 93° 38' x 61° 50'
M.O.D. from Front of Lens	54 mm 10° 09' x 5° 43'
Object Dimensions at M.O.D. 16:9 Aspect Ratio	(2X) 9 mm 56° 06' x 33° 20'
Filter Size	108 mm 5° 05' x 2° 52'
Dia ø x Length (w/o Hood)	0.59 m
Weight (w/o Hood)	0.3 m
Features	4.5 mm 757 x 425 mm
	54 mm 59 x 33 mm
	(2X) 9 mm 373 x 210 mm
	108 mm 31 x 17 mm
	ø 127 mm P=0.75 (In Hood)
	ø 95 x 237.5 mm
	2.0 kg (RM) / 2.07 kg (RD)
	16 Bit Encoders (RM / RD only) Inner Focus / Zoom Limit / Quick Zoom

\*RD contain Servos for Zoom and Focus.

# LENSES FOR 2/3" HD CAMERAS

## SELECT Series

**ZA17x7.6B RM/RD\*/ZD\*\***  
**ZA17x7.6BE RM/RD\*/ZD#**



LENS	ZA17x7.6B RM/RD*/ZD**	ZA17x7.6BE RM/RD*/ZD#
Zoom Ratio / Format	17X / 2/3"	17X / 2/3"
Focal Length	7.6 to 130 mm	7.6 to 130 mm (2X) 15.2 to 260 mm
Maximum Relative Aperture	1:1.8 (7.6 ~ 102 mm) 1:2.3 (130 mm)	1:1.8 (7.6 ~ 102 mm) 1:2.3 (130 mm)
Maximum Photometric Aperture T-No.	T1.9 (7.6 ~ 102 mm) T2.5 (130 mm)	T1.9 (7.6 ~ 102 mm) T2.5 (130 mm)
Angular Field of View 16:9 Aspect Ratio	7.6 mm 64° 30' x 39° 03' 130 mm 4° 13' x 2° 23'	7.6 mm 64° 30' x 39° 03' 130 mm 4° 13' x 2° 23' (2X) 15.2 mm 35° 01' x 20° 07' 260 mm 2° 07' x 1° 11'
M.O.D. from Image Plane	0.84 m	0.84 m
M.O.D. from Front of Lens	0.6 m	0.6 m
Object Dimensions at M.O.D. 16:9 Aspect Ratio	7.6 mm 696 x 392 mm 130 mm 43 x 24 mm	7.6 mm 696 x 392 mm 130 mm 43 x 24 mm (2X) 15.2 mm 362 x 204 mm 260 mm 21 x 12 mm
Filter Size	ø 82 mm P=0.75 (On Barrel)	ø 82 mm P=0.75 (On Barrel)
Dia ø x Length (w/o Hood)	ø 85 x 203 mm	ø 85 x 204 mm
Weight (w/o Hood)	1.43 kg (RM) / 1.5 kg (RD/ZD)	1.54 kg (RM) / 1.61 kg (RD/ZD)
Options	Quick Frame 16 Bit Encoders (ZD only)	Quick Frame 16 Bit Encoders (ZD only)
Features	16 Bit Encoders (RM/RD only) Zoom Limit / Quick Zoom Inner Focus	16 Bit Encoders (RM / RD only) Zoom Limit / Quick Zoom Inner Focus

## SELECT Series

**ZA22x7.6B RM/RD\***  
**ZA22x7.6BE RM/RD\***



LENS	ZA22x7.6B RM/RD*	ZA22x7.6BE RM/RD*
Zoom Ratio / Format	22X / 2/3"	22X / 2/3"
Focal Length	7.6 to 167 mm	7.6 to 167 mm (2X) 15.2 to 334 mm
Maximum Relative Aperture	1:1.8 (7.6 ~ 120 mm) 1:2.5 (167 mm)	1:1.8 (7.6 ~ 120 mm) 1:2.5 (167 mm)
Maximum Photometric Aperture T-No.	T1.9 (7.6 ~ 120 mm) T2.6 (167 mm)	T1.9 (7.6 ~ 120 mm) T2.6 (167 mm)
Angular Field of View 16:9 Aspect Ratio	7.6 mm 64° 30' x 39° 03' 167 mm 3° 17' x 1° 51'	7.6 mm 64° 30' x 39° 03' 167 mm 3° 17' x 1° 51' (2X) 15.2 mm 35° 01' x 20° 07' 334 mm 1° 39' x 0° 55'
M.O.D. from Image Plane	1.07 m	1.07 m
M.O.D. from Front of Lens	0.8 m	0.8 m
Object Dimensions at M.O.D. 16:9 Aspect Ratio	7.6 mm 915 x 514 mm 167 mm 43 x 24 mm	7.6 mm 915 x 514 mm 167 mm 43 x 24 mm (2X) 15.2 mm 473 x 266 mm 334 mm 22 x 12 mm
Filter Size	ø 95 mm P=1.0 (On Barrel) ø 107 mm P=1.0 (In Hood)	ø 95 mm P=1.0 (On Barrel) ø 107 mm P=1.0 (In Hood)
Dia ø x Length (w/o Hood)	ø 100 x 222.6 mm	ø 100 x 222.6 mm
Weight (w/o Hood)	1.73 kg (RM) / 1.8 kg (RD)	1.85 kg (RM) / 1.92 kg (RD)
Features	16 Bit Encoders (RM/RD only) Zoom Limit / Quick Zoom Inner Focus	16 Bit Encoders (RM/RD only) Zoom Limit / Quick Zoom Inner Focus

\*RD contain Servos for Zoom and Focus.

\*\*ZD contains Quick Frame / Precision Zoom Focus System.

# ZD special order.

# LENSES FOR 2/3" HD CAMERAS

Exceed Series 2/3 inch lenses feature digital servos. The XA20sx8.5BERM, with 170mm maximum focal length, offers economy minded users a long ENG lens with a 2x extender at an attractive price point. The XA16s-x8BRAM, a new generation of lens, with a rear focusing group and remarkably reduced breathing, offers the user a compact, high quality lens in a compact design.

Featuring QuickZoom, CruiseZoom, and a wide variety of controls and adapters, make any of the Exceed Series lenses a great choice. The features, quality, and price level make them a performance packed, smart addition to your camera.

## XA16sx8BRAM



Zoom Ratio / Format	16X / 2/3"
Focal Length	8.0 to 128 mm
Maximum Relative Aperture	1:9 (8 mm) 1:2.8 (128 mm)
Angular Field of View	8 mm 61° 52' x 37° 14'
16:9 Aspect Ratio	128 mm 4° 17' x 2° 25'
M.O.D. from Image Plane	1.0 m
M.O.D. from Front of Lens	0.8 m
Object Dimensions at M.O.D. 16:9 Aspect Ratio	8 mm 1023 x 575 mm 128 mm 98 x 55 mm
Filter Size	ø 82 P= 0.75
Dia ø x Length (w/o Hood)	ø 85 x 163.8 mm
Weight (w/o Hood)	1.52 kg
Features	Rear Focus

## XA20sx8.5BRM



Zoom Ratio / Format	20X / 2/3"
Focal Length	8.5 - 170 mm
Maximum Relative Aperture	1:1.8 (8.5 ~ 113 mm) 1:2.7 (170 mm)
Angular Field of View	8.5 mm 58° 51' x 35° 11'
16:9 Aspect Ratio	170 mm 3° 14' x 1° 49'
M.O.D. from Image Plane	1.1 m
M.O.D. from Front of Lens	0.9 m
Object Dimensions at M.O.D. 16:9 Aspect Ratio	8.5 mm 910x511 mm 170 mm 47x26 mm
Filter Size	ø 82 P= 0.75
Dia ø x Length (w/o Hood)	ø 85 x 180.8 mm
Weight (w/o Hood)	1.5 kg
Features	Inner Focus / Quick Zoom

## XA20sx8.5BERM



Zoom Ratio / Format	20X / 2/3"
Focal Length	8.5 - 170 mm (2X) 17 - 340 mm
Maximum Relative Aperture	1:1.8 (8.5 ~ 113 mm) 1:2.7 (170 mm)
Angular Field of View	8.5 mm 58° 51' x 35° 11'
16:9 Aspect Ratio	170 mm 3° 14' x 1° 49' (2X) 17 mm 31° 30' x 18° 01' 340 mm 1° 37' x 0° 54'
M.O.D. from Image Plane	1.1 m 0.59 m
M.O.D. from Front of Lens	0.9 m
Object Dimensions at M.O.D. 16:9 Aspect Ratio	8.5 mm 910 x 511 mm 170 mm 47 x 26 mm (2X) 17 mm 469 x 264 mm 340 mm 24 x 13 mm
Filter Size	ø 82 P= 0.75
Dia ø x Length (w/o Hood)	ø 85 x 200.8 mm
Weight (w/o Hood)	1.58 kg
Features	Inner Focus / Quick Zoom



**WCV-X85 - Wide Converter available see page 31.**

# HDTV STUDIO LENSES

Studio lenses are essential for applications requiring the ultimate in control and optical quality. The Compact XA22x7BES studio lens featuring sharp images, superb corner resolution and quite precise servo zoom and focus in a compact package is designed for mounting to 2/3 inch ENG style cameras.



## XA22x7BES

Zoom Ratio / Format	22X / 2/3"
Focal Length	7.0 ~ 154 mm (2X) 14 ~ 308 mm
Maximum Relative Aperture	1:1.8 (7 ~ 116 mm) 1:2.4 (154 mm)
Maximum Photometric Aperture T-No.	1:2.2 (7 ~ 116 mm) T2.9 (154 mm)
Angular Field of View (Hor. x Vert. in °)	7.0 mm 68° 49' x 42° 07' 154 mm 3° 34' x 2° 00'
16:9 Aspect Ratio	(2X) 14 mm 37° 49' x 21° 48' 308 mm 1° 47' x 1° 0'
M.O.D. from Image Plane	1.17 m
M.O.D. from Front of Lens	0.8 m
Object Dimensions at M.O.D. (Hor. x Vert. in mm)	7.0 mm 1197 x 673 mm 154 mm 54 x 31 mm (2X) 14 mm 599 x 337 mm
16:9 Aspect Ratio	308 mm 27 x 15 mm
Size (HxWxL)	179 x 187 x 340 mm
Weight	6.6 kg
Features	16 Bit Encoders / FIND / Auto Compensation of Focus Breathing / Virtual Reality Output / Dust Proof and Anti-Fog / 2.2X Extender

\* Some features require optional control or software.



## HA27x6.5BESM

Zoom Ratio / Format	27X / 2/3"
Focal Length	6.5 ~ 180 mm (2X) 13 ~ 360 mm
Maximum Relative Aperture	1:1.5 (6.5 ~ 123 mm) 1:2.2 (180 mm)
Maximum Photometric Aperture T-No.	T1.6 (6.5 ~ 123 mm) T2.4 (180 mm)
Angular Field of View (Hor. x Vert. in °)	6.5 mm 72° 50' x 45° 02' 180 mm 3° 03' x 1° 43'
16:9 Aspect Ratio	(2X) 13 mm 40° 30' x 23° 25' 360 mm 1° 32' x 0° 51'
M.O.D. from Image Plane	1.18 m
M.O.D. from Front of Lens	0.6 m
Object Dimensions at M.O.D. (Hor. x Vert. in mm)	6.5 mm 1053 x 592 mm 180 mm 39 x 22 mm (2X) 13 mm 527 x 296 mm
16:9 Aspect Ratio	360 mm 20 x 11 mm
Size (HxWxL)	233 x 231 x 539 mm
Weight (w/o Hood)	19.7 kg
Features	Advanced Back Focus / Remote Macro / FIND / Focus Fader / Auto Compensation of Focus Breathing / Dust Proof & Anti Fogging / Virtual Reality Output

\* Some features require optional control or software.

# HDTV FIELD LENSES



The very popular XA55X9.5BESM with built in camera supporter is now available for hard cameras and system expanders. All of Fujinon's Field lenses feature the exclusive desiccant system for removal of moisture caused by condensation.



**OS-TECH**

## XA55x9.5BESM

Zoom Ratio / Format	55X / 2/3"
Focal Length	9.5 to 525 mm (2X) 19 to 1050 mm
Maximum Relative Aperture	1:1.7 (9.5 ~ 307 mm) 1:2.9 (525 mm)
Maximum Photometric Aperture T-No.	T1.85 (9.5 ~ 307 mm) T3.61 (525 mm)
Angular Field of View (Hor. x Vert. in °)	9.5 mm 53° 34' x 31° 41'
16:9 Aspect Ratio	(2X) 525 mm 1° 03' x 0° 35' 19 mm 28° 20' x 16° 09' 950 mm 0° 32' x 0° 18'
M.O.D. from Image Plane	3.9 m
M.O.D. from Front of Lens	3.0 m
Object Dimensions at M.O.D.	9.5 mm 2782 x 1564 mm
(Hor. x Vert. in mm)	(2X) 525 mm 51 x 29 mm 19 mm 1406 x 790 mm 950 mm 26 x 15 mm
16:9 Aspect Ratio	
Size (HxWxL)	253 x 253 x 876 mm
Weight	24.8 kg w/support 21.0 w/o support
Options	Transit Case / With or Without Support Bracket
Features	Built-in OS-TECH / Dust Proof & Anti Fogging / 16 bit Virtual Reality Output

## XA77x9.5BESM

**OS-TECH**



Zoom Ratio / Format	77X / 2/3"
Focal Length	9.5 ~ 732 mm (2X) 19.0 ~ 1464 mm
Maximum Relative Aperture	1:1.7 (9.5 ~ 335 mm) 1:3.8 (732 mm)
Maximum Photometric Aperture T-No.	T1.9 (9.5 ~ 335 mm) T4.1 (732 mm)
Angular Field of View (Hor. x Vert. in °)	9.5 mm 53° 34' x 31° 41'
16:9 Aspect Ratio	(2X) 732 mm 0° 45' x 0° 25' 18.6 mm 28° 20' x 16° 09' 1464 mm 0° 23' x 0° 13'
M.O.D. from Image Plane	3.4 m
M.O.D. from Front of Lens	2.7 m
Object Dimensions at M.O.D.	9.5 mm 2425 x 1363 mm
(Hor. x Vert. in mm)	(2X) 732 mm 32 x 18 mm 19.0 mm 1241 x 697 mm 1464 mm 16 x 9 mm
16:9 Aspect Ratio	
Size (HxWxL)	253 x 253 x 656.4 mm
Weight	22.4 kg
Features	Advanced Back Focus / Remote Macro / Focus Fader / Built-In OS-TECH / Dust Proof & Anti Fogging / FIND / 16 Bit Virtual Reality Output

\* Some features require optional control or software.

# HDTV FIELD LENSES

## XA88x 8.8BESM

### OS-TECH



Zoom Ratio / Format	88X / 2/3"
Focal Length	8.8 ~ 777 mm (2X) 17.6 ~ 1554 mm
Maximum Relative Aperture	1:1.7 (8.8 ~ 348 mm) 1:3.8 (777 mm)
Maximum Photometric Aperture T-No.	T1.8 (8.8 ~ 348 mm) T3.6 (777 mm)
Angular Field of View (Hor. x Vert. in °)	8.8 mm 52° 10' x 34° 03' 777 mm 0° 42' x 0° 24'
16:9 Aspect Ratio	(2X) 17.6 mm 30° 29' x 17° 25' 1554 mm 0° 21' x 0° 12'
M.O.D. from Image Plane	3.51 m
M.O.D. from Front of Lens	2.9 m
Object Dimensions at M.O.D.	8.8 mm 2971 x 1670 mm 777 mm 34 x 19 mm
(Hor. x Vert. in mm)	(2X) 17.6 mm 1485 x 835 mm 1554 mm 17 x 9 mm
16:9 Aspect Ratio	
Size (HxWxL)	265 x 270 x 575 mm
Weight	24.0 kg
Features	Advanced Back Focus / Remote Macro / Focus Fader / Built-In OS-TECH / Dust Proof & Anti Fogging / Virtual Reality Output / FIND

\* Some features require optional control or software.

## XA88x 12.5BESM

### OS-TECH



Zoom Ratio / Format	88X / 2/3"
Focal Length	12.5 ~ 1100 mm (2X) 25 ~ 2200 mm
Maximum Relative Aperture	1:2.3 (12.5 ~ 477 mm) 1:5.3 (1100 mm)
Maximum Photometric Aperture T-No.	T2.4 (12.5 ~ 477 mm) T5.6 (1100 mm)
Angular Field of View (Hor. x Vert. in °)	12.5 mm 41° 58' x 24° 20' 1100 mm 0° 30' x 0° 17'
16:9 Aspect Ratio	(2X) 25 mm 21° 43' x 12° 18' 2200 mm 0° 15' x 0° 08'
M.O.D. from Image Plane	3.53 m
M.O.D. from Front of Lens	2.9 m (12.5 ~ 200 mm) 3.5 m (205 ~ 1100 mm)
Object Dimensions at M.O.D.	12.5 mm 2091 x 1175 mm 1100 mm 24 x 13 mm
(Hor. x Vert. in mm)	(2X) 25 mm 1046 x 588 mm 2200 mm 12 x 7 mm
16:9 Aspect Ratio	
Size (HxWxL)	265 x 270 x 593 mm
Weight	24.5 kg
Features	Advanced Back Focus / Remote Macro / Focus Fader / Built-In OS-TECH / Dust Proof & Anti Fogging / FIND / Virtual Reality Output

\* Some features require optional control or software.

# HDTV FIELD LENSES



## XA99x8.4BESM

OS-TECH

Zoom Ratio / Format	99X / 2/3"
Focal Length	8.4 ~ 832 mm (2X) 16.8 ~ 1664 mm
Maximum Relative Aperture	1:1.7 (8.4 ~ 341 mm) 1:4.15 (832 mm)
Maximum Photometric Aperture T-No.	T1.85 (8.4 ~ 341 mm) T4.52 (832 mm)
Angular Field of View (Hor. x Vert. in °)	8.4 mm 59° 26' x 35° 35' 832 mm 0° 40' x 0° 22'
16:9 Aspect Ratio	(2X) 16.8 mm 31° 52' x 18° 14' 1664 mm 0° 20' x 0° 11'
M.O.D. from Image Plane	2.9 m
M.O.D. from Front of Lens	3.55 m
Object Dimensions at M.O.D.	8.4 mm 2950 x 1658 mm 832 mm 31 x 17 mm
(Hor. x Vert. in mm)	(2X) 16.8 mm 1538 x 864 mm 1664 mm 16 x 9 mm
16:9 Aspect Ratio	
Size (HxWxL)	264 x 258 x 610 mm
Weight	23.5 kg
Features	16bit encoders / New Advanced Stabi - OS-TECH FIND Intelligent Diagnostic System Dust proof and anti-fogging / Advanced back focus HT-EBC Coatings / Virtual Reality Output / Focus Fader

\* Some features require optional control or software.



## XA101x8.9BESM

OS-TECH

Zoom Ratio / Format	101X / 2/3"
Focal Length	8.9 ~ 900 mm (2X) 17.8 ~ 1800 mm
Maximum Relative Aperture	1:1.7 (8.9 ~ 291 mm) 1:4.7 (900 mm)
Maximum Photometric Aperture T-No.	T1.8 (8.9 ~ 291 mm) T5.0 (900 mm)
Angular Field of View (Hor. x Vert. in °)	8.9 mm 56° 38' x 33° 42' 900 mm 0° 37' x 0° 21'
16:9 Aspect Ratio	(2X) 17.8 mm 30° 09' x 17° 13' 1800 mm 0° 18' x 0° 10'
M.O.D. from Image Plane	3.59 m
M.O.D. from Front of Lens	2.9 m
Object Dimensions at M.O.D.	8.9 mm 2865 x 1610 mm 900 mm 28 x 16 mm
(Hor. x Vert. in mm)	(2X) 17.8 mm 1433 x 805 mm 1800 mm 14 x 8 mm
16:9 Aspect Ratio	
Size (HxWxL)	265 x 270 x 660 mm
Weight	23.8 kg
Features	Advanced Back Focus / Remote Macro / Focus Fader Built-In OS-TECH / Dust Proof & Anti Fogging / Virtual Reality Output / FIND

\* Some features require optional control or software.

# HDTV VIDEOCONFERENCING LENSES

Fujinon's HD remote control lenses are ideal for videoconferencing, tower cam and other applications requiring remote control of zoom, focus, and iris functions.

## EXCEED Series

### XT17sx4.5BMD



Zoom Ratio / Format	17X / 1/3"
Focal Length	4.5 to 77 mm
Maximum Relative Aperture	1:1.6 (4.5 ~ 77 mm)
Angular Field of View	4.5 mm 60° 19' x 36° 11'
16:9 Aspect Ratio	77 mm 3° 53' x 2° 11'
M.O.D. from Image Plane	1.16 m
M.O.D. from Front of Lens	0.95 m
Object Dimensions at M.O.D.	4.5 mm 999 x 562 mm 77 mm 60 x 34 mm
Filter Size	ø 82 mm P=0.75
Dia ø x Length (w/o Hood)	ø 85 x 175.6 mm
Weight (w/o Hood)	1.38 kg

## EXCEED Series

### XA20sx8.5B MD/EMD\*



Zoom Ratio / Format	20X / 2/3"
Focal Length	8.5 - 170 mm
	(2X) 17 - 340 mm
Maximum Relative Aperture	1:1.8 (8.5 ~ 113 mm) 1:2.7 (170 mm)
Angular Field of View	8.5 mm 58° 51' x 35° 01'
16:9 Aspect Ratio	170 mm 3° 14' x 1° 49' (2X) 17 mm 31° 30' x 18° 01' 340 mm 1° 37' x 0° 54'
M.O.D. from Image Plane	1.1 m 0.59 m
M.O.D. from Front of Lens	0.9 m
Object Dimensions at M.O.D.	8.5 mm 910 x 511 mm 170 mm 47 x 26 mm (2X) 17 mm 469 x 264 mm 340 mm 24 x 13 mm
Filter Size	ø 82 mm P= 0.75
Dia ø x Length (w/o Hood)	ø 85 x 180.8 mm
Weight (w/o Hood)	1.9 kg (2X) 2.0 kg

## SELECT Series

### ZA12x4.5B MD/EMD\*



Zoom Ratio / Format	12X / 2/3"
Focal Length	4.5 to 54 mm
	(2X) 9 to 108 mm
Maximum Relative Aperture	1:1.8 (4.5 ~ 41 mm) 1:2.4 (54 mm)
Angular Field of View	4.5 mm 93° 38' x 61° 50'
16:9 Aspect Ratio	54 mm 10° 09' x 5° 43' (2X) 9 mm 56° 06' x 33° 20' 108 mm 5° 05' x 2° 52'
M.O.D. from Image Plane	0.59 m
M.O.D. from Front of Lens	0.3 m
Object Dimensions at M.O.D.	4.5 mm 757 x 425 mm 54 mm 59 x 33 mm (2X) 9 mm 373 x 210 mm 108 mm 31 x 17 mm
Filter Size	ø 127 mm P=0.75 (In Hood)
Dia ø x Length (w/o Hood)	ø 95 x 237.5 mm
Weight (w/o Hood)	2.0 kg (2X) 2.12 kg

\*EMD version with manual extender

# HDTV VIDEOCONFERENCING LENSES

## SELECT

Series

### ZA17x7.6B MD/EMD\*



Zoom Ratio / Format	17X / 2/3"
Focal Length	7.6 to 130 mm (2X) 15.2 to 260 mm
Maximum Relative Aperture	1:1.8 (7.6~ 102 mm) 1:2.3 (130 mm)
Angular Field of View 16:9 Aspect Ratio	7.6 mm 64° 30' x 39° 03' 130 mm 4° 13' x 2° 23' (2X) 15.2 mm 35° 01' x 20° 07' 260 mm 2° 07' x 1° 11'
M.O.D. from Image Plane	0.84 m
M.O.D. from Front of Lens	0.6 m
Object Dimensions at M.O.D. 16:9 Aspect Ratio	7.6 mm 696 x 392 mm 130 mm 43 x 24 mm (2X) 15.2 mm 362 x 204 mm 260 mm 22x 12 mm
Filter Size	ø 85 mm P=0.75
Dia ø x Length (w/o Hood)	ø 85 x 204 mm
Weight (w/o Hood)	1.9 kg (2X) 2.0 kg

◇ For remote application of extender, the ECU motorized extender unit is required.

## SELECT

Series

### ZA22x7.6B MD/EMD\*



Zoom Ratio / Format	22X / 2/3"
Focal Length	7.6 to 167 mm (2X) 15.2 to 334 mm
Maximum Relative Aperture	1:1.8 (7.6 ~ 120 mm) 1:2.5 (167 mm)
Angular Field of View 16:9 Aspect Ratio	7.6 mm 64° 30' x 39° 03' 167 mm 3° 17' x 1° 51' (2X) 15.2 mm 35° 01' x 20° 07' 334 mm 1° 39' x 0° 55'
M.O.D. from Image Plane	1.07 m
M.O.D. from Front of Lens	0.8 mm
Object Dimensions at M.O.D.	7.6 mm 915 x 514 mm 167 mm 43 x 24 mm (2X) 15.2 mm 473 x 266 mm 334 mm 22 x 12 mm
Filter Size	ø 95 mm P=1.0 (On Barrel)
Weight (w/o Hood)	1.72 kg (2X) 2.0 kg

\*EMD version with manual extender

## PREMIER

Series

### HAs18x7.6BMD#



Zoom Ratio / Format	18X / 2/3"
Focal Length	7.6 mm ~ 137 mm
Maximum Relative Aperture	1:1.8 (7.6 mm ~ 103 mm) 1:2.4 (137 mm)
Angular Field of View (Hor. x Vert. in °)	7.6 mm 64° 30' x 39° 03' 137 mm 4° 01' x 2° 15'
M.O.D. from Image Plane	0.84 m
M.O.D. from Front of Lens	0.6 m
Object Area (at Wide) at M.O.D. (at Tele)	7.6 mm 696 x 392 mm 137 mm 41 x 23 mm
Filter Size	ø 82mm P=0.75
Weight w/o hood	1.55 kg

\*Optional Accessory Configuration SS-33A for model HAs18x7.6B MD only.  
Refer to pg. 33 for Standard Videoconferencing Accessories.

# Special order.

# ACCESSORIES: HD PF CONTROLS ENG/EFP

## SS-13PF/EPA Servo Focus/Servo Zoom

For use with PF ENG lenses.

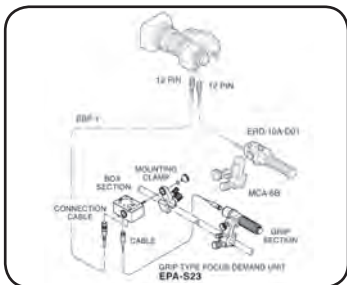

- A. ERD-10A-D01M Digi Zoom Demand
- B. EBF-1 Focus Cable
- C. MCA-06BC Mounting Clamp
- D. EPA-S23 (Part of Kit) Focus Grip Section
- E. EPA-S23 (Part of Kit) Focus Box Section
- F. EPA-S23 (Part of Kit) Focus Connection Cable
- G. PF-19A-02A PF Action Switch

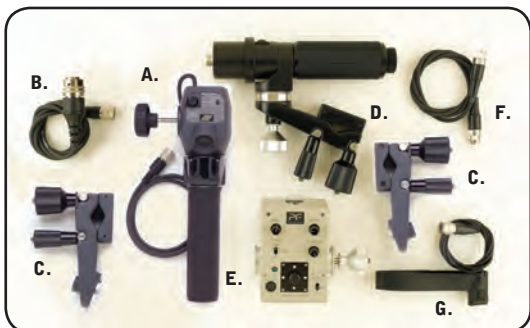

## SS-21PF/EPA Servo Focus/Servo Zoom

For use with PF EFP lenses

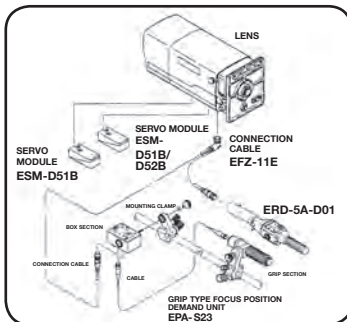

- A. ERD-30A-D01 Digi Zoom Demand
- B. EFZ-11E Focus/Zoom Cable
- C. ESM-51B Servo Module
- D. EPA-S23 (Part of Kit) Focus Grip Section
- E. EPA-S23 (Part of Kit) Focus Box Section
- F. EPA-S23 (Part of Kit) Focus Connection Cable
- G. MCA-06BC Mounting Clamp
- H. PF-19A-02A PF Action Switch

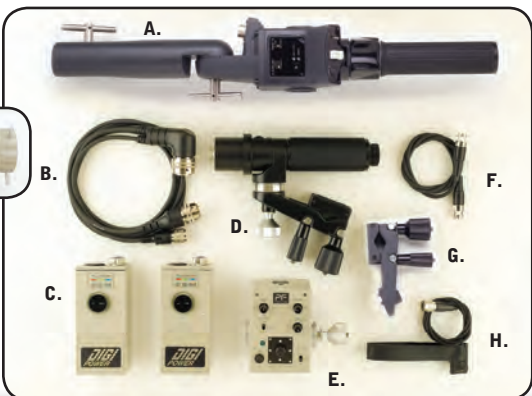

EPD-4A-S13E Digi PF Focus Demand also available.

Note: Some accessories will be delivered in dark grey color.

# ACCESSORIES: HD & SD ENG/EFP

## THREE-MODE FINE FOCUS

By shifting the sensitivity from the wide side to the telephoto side of the focus range, this control provides more precise focusing for studio or sports productions.

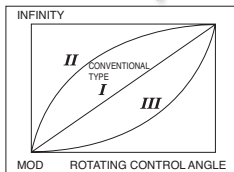

## SERIAL DIGITAL REMOTE CONTROL BY PC

Remote control of zoom, focus and iris for Digi-Power lenses is possible via serial digital link, providing accurate positioning for virtual studio and other applications requiring digital precision.

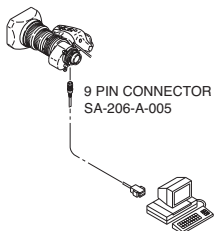

## DIGI ZOOM DEMAND\*

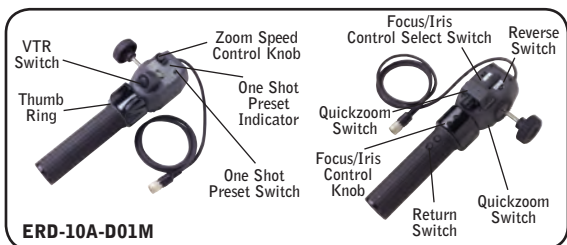

**ERD-10A-D01M**

\*New Digital features only available on ERM/ERD-M/S.

- A. CFC-990 Flex Cable
- B. FMM-3C/6B Manual Module
- C. ZMM-6 Manual Module
- D. EBF-1 Focus Cable
- E. MCA-36
- F. ERD-20A-A02 Zoom Demand
- G. FSP-13G Focus Positional Module
- H. EPD-31A-D02
- I. CZH-14 Focus Handle
- J. CFH-11 Focus Handle
- K. MCA-7 Mounting Clamp
- L. EPD-21A-A02 Focus Demand
- M. ERD-10A-D01M Zoom Demand
- N. ALH-117C-01A Support for HA36x/A36x HA42x

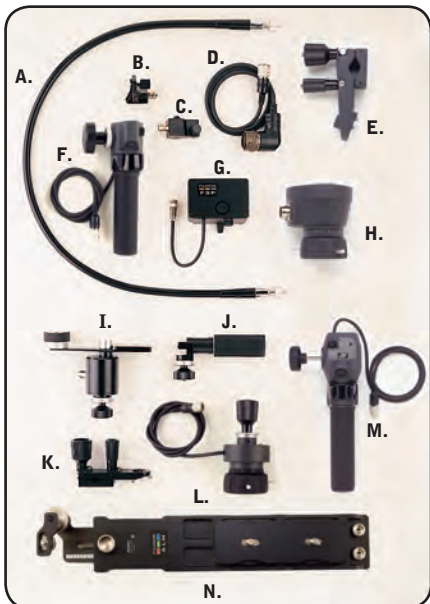

# ACCESSORIES: HD & SD ENG/EFP

## DIGI POWER REAR CONTROL KITS

**MS-11D Manual Focus/Servo Zoom**  
For use with RM/ZM type lenses.

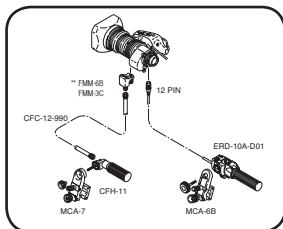

**SS-11D Servo Focus/Servo Zoom**  
For use with RM/ZM type lenses.

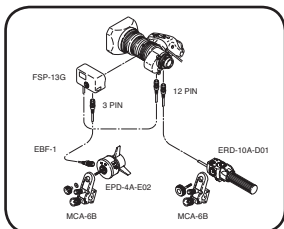

**SS-13D Servo Focus/Servo Zoom**  
For use with RD/ZD type lenses.

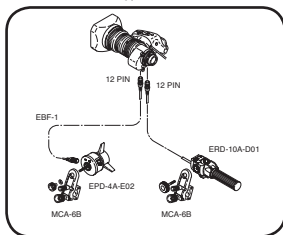

**SS-14S Servo Focus/Servo Zoom**  
For use with RD/ZD type lenses.

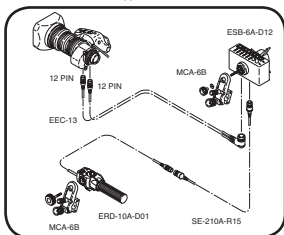

## STANDARD REAR CONTROL KITS

**MS-11 Manual Focus/Servo Zoom**

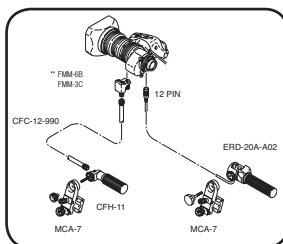

**SS-11 Servo Focus/Servo Zoom**  
Not available on HA42x, HA36x and A36

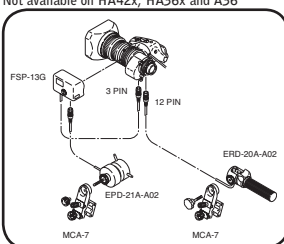

**SS-13A Servo Focus/Servo Zoom**  
For use with ERD type lenses.

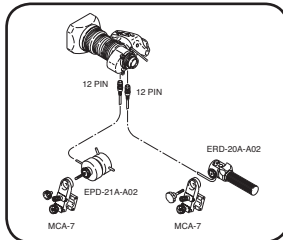

**MM-11 Manual Focus/Manual Zoom**  
Not available on HA42x, HA36x and A36x

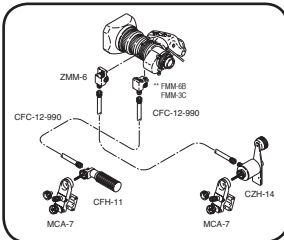

\*Specify camera type

\*\*FMM-3C for use on HA42x and HA25x

## MOUNTING SYSTEM

Fujinon has replaced the "cone" shaped mounting system with the "tooth" system. The cone type may still be ordered as a special order.



New Style  
MCA-7



Old Style  
MCA-1A  
(Discontinued)

## PROFESSIONAL REAR CONTROL KITS

**MS-01 Manual Focus/Servo Zoom**  
MS-X1 for XA16sx8BRAM, XA16x and XS16x only

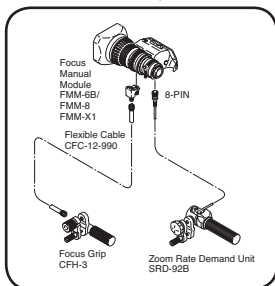

**MM-01 Manual Focus/Manual Zoom**  
Not available on S16x7.3

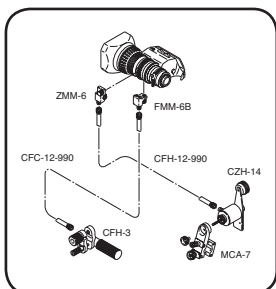

**SS-01 Servo Focus/Servo Zoom**  
Not available on S16x7.3

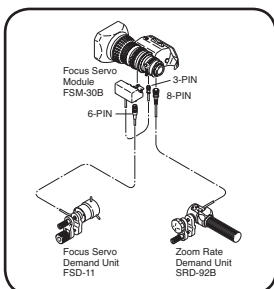

\*Specify camera type.

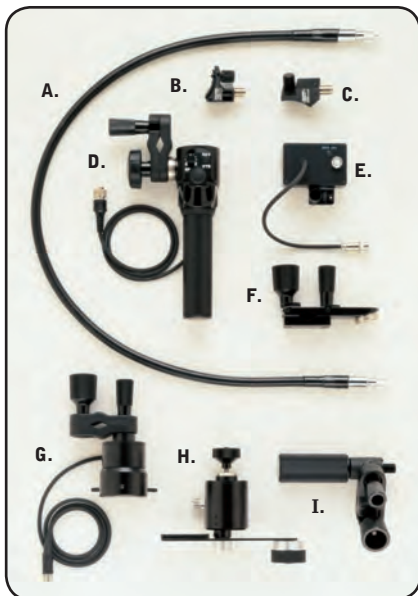

- A. CFC-990 Flex Cable
- B. FMM-6B/FMM-8\*  
FMM-X1 Focus Manual Module
- C. ZMM-6 Zoom Manual Module
- D. SRD-92B Zoom Demand
- E. FSM-30B Focus Servo Module
- F. MCA-7 Mounting Clamp
- G. FSD-11 Focus Demand
- H. CZH-14 Zoom Handle
- I. CFH-3 Focus Handle

# ACCESSORIES: HD ENG/EFP

## LENS CONVERTERS

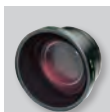

### Wide Converter (WCV-X85)

XT17sx4.5  
XT20sx4.7  
XA16sx8  
XA20sx8.5



### Wide Converter (WCV)



### Tele Converter (TCV)

## HD/ENG LENS CONVERTERS

Model	Type	Ø Size	Converter*	Mag.	Converted Focal Length (mm)	M.O.D. (m)	Weight (kg)
HS16x4.6	TELE	95 mm	TCV-H95	1.5x	74.0→111.0	0.90	1.00
	WIDE	95 mm	WCV-H95	0.8x	4.6→3.9	0.29	1.00
HS18x5.5/ HSs18x5.5	TELE	85 mm	TCV-H85	1.5x	100.0→150.0	1.35	1.10
	WIDE	85 mm	WCV-H85	0.8x	5.5→4.4	0.38	1.05
	WIDE	85 mm	WAT-H85	0.7x	5.5→3.9	0.29	0.36
	FISHEYE	85 mm	F-ATH85	0.57x	5.5→3.1	0.19	0.36
HA16x6.3	TELE	95 mm	TCV-H955	1.5x	101.0→152.0	0.90	1.00
	WIDE	95 mm	WCV-H95	0.8x	6.3→5.4	0.29	1.00
HA18x7.6E/ HAS18x7.6	TELE	85 mm	TCV-H85	1.5x	137.0→205.5	1.35	1.10
	WIDE	85 mm	WCV-H85	0.8x	7.6→6.1	0.38	1.05
	WIDE	85 mm	WAT-H85	0.7x	7.6→5.3	-	0.36
HA19x7.4BE	TELE	100 mm	TCV-H100	1.5x	141.0→211.5	1.24	1.00
	WIDE	100 mm	WCV-H100	0.8x	7.4→5.9	0.35	1.05
	WIDE	100 mm	WAT-H100	0.7x	7.4→5.2	0.27	0.53
HA22x7.3E	TELE	110 mm	TCV-H110	1.5x	161.0→242.0	1.90	1.10
HA23x7.6E	TELE	100 mm	TCV-H100	1.5x	175.0→262.5	1.80	1.00
	WIDE	100 mm	WCV-H100	0.8x	7.6→6.1	0.51	1.05
	WIDE	100 mm	WAT-H100	0.7x	7.6→5.3	0.39	0.53
XT17sx4.5	WIDE	85 mm	WCV-X85	0.8x	4.5→3.6	0.61	0.75
XT20sx4.7	WIDE	85 mm	WCV-X85	0.8x	4.7→3.76	0.58	0.75
XA16sx8	WIDE	85 mm	WCV-X85	0.8x	8→6.4	0.51	0.75
XA20sx8.5	WIDE	85 mm	WCV-X85	0.8x	8.5→6.8	0.58	0.75
XS17x5.5/ ZS17x5.5	TELE	85 mm	TCV-H85	1.5x	94.0→141.0	1.35	1.10
	WIDE	85 mm	WCV-H85	0.8x	5.5→4.4	0.38	1.05
	WIDE	85 mm	WAT-H85	0.7x	5.5→3.8	0.29	0.36
ZA17x7.6	FISHEYE	85 mm	F-ATH85	0.57x	5.5→3.1	0.19	0.36
	TELE	85 mm	TCV-H85	1.5x	130.0→195.0	1.35	1.10
	WIDE	85 mm	WCV-H85	0.8x	7.6→6.1	0.38	1.05
	WIDE	85 mm	WAT-H85	0.7x	7.6→5.3	0.29	0.36
ZA22x7.6	TELE	100 mm	TCV-H100	1.5x	167.0→250.5	1.80	1.00
	WIDE	100 mm	WCV-H100	0.8x	7.6→6.1	0.51	1.05
	WIDE	100 mm	WAT-H100	0.7x	7.6→5.3	0.39	0.53

\*TCV/WCV are zoom thru type \*\*Ø 95mm P-1 screw on type

Wide attachment and fisheye attachment can be used at WIDE END.

Number of M.O.D. is at wide end.

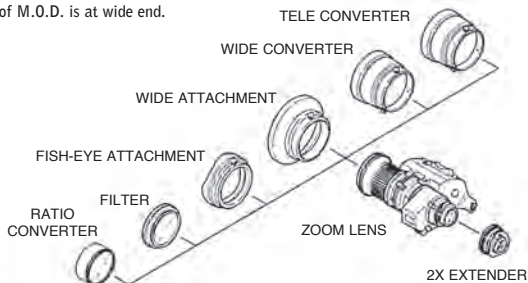

## ACCESSORIES: SD ENG/EFP



Wide Attachment  
(WAT)



Fish-Eye Attachment  
(F-AT)

### PROFESSIONAL LENS CONVERTERS

Model	Type	ø Size	Converter	Mag.	Converted Focal Length (mm)	M.O.D. (m)	Weight (kg)
A13x6.3	TELE	85 mm	TCV-85C	1.6x	82.0→131.2	1.02	1.15
RM/ERM	WIDE	85 mm	WCV-85C	0.8x	6.3→ 5.0	0.26	1.09
	WIDE	85 mm	WAT-85C	0.7x	6.3→ 4.4	-	0.55
A20x8.6	TELE	85 mm	TCV-85C	1.6x	172.0→275.2	2.30	1.15
RM/ERM	WIDE	85 mm	WCV-85C/L85	0.8x	8.6→ 6.9	0.58	1.09/57
	WIDE	85 mm	WAT-85C	0.7x	8.6→ 6.0	-	0.55
	FISHEYE	85 mm	F-AT85C	Approx. 0.55x	—	-	0.62
	RATIO	82 mm	RCV-82SC	0.82x	8.6→ 7.1	0.61	0.25
S13x4.6	TELE	85 mm	TCV-85C	1.6x	60.0→96.0	1.02	1.03
RM/ERM	WIDE	85 mm	WCV-85C	0.8x	4.6→ 3.7	0.26	1.09
	WIDE	85 mm	WAT-85C	0.7x	4.6→ 3.2	-	0.55
S17x6.6	TELE	85 mm	TCV-85C	1.6x	114→182.4	2.30	1.15
RM	WIDE	85 mm	WCV-85C	0.8x	6.6→ 5.3	0.58	1.09
	WIDE	85 mm	WAT-85C	0.7x	6.6→ 4.6	-	0.55
	FISHEYE	85 mm	F-AT85C	Approx. 0.55x	—	-	0.62
S20x6.4	TELE	85 mm	TCV-85C	1.6x	128.0→ 204.8	2.30	1.15
RM/ERM	WIDE	85 mm	WCV-85C/L85	0.8x	6.4→ 5.1	0.58	1.09/57
	WIDE	85 mm	WAT-85C	0.7x	6.4→ 4.5	-	0.55
	FISHEYE	85 mm	F-AT85C	Approx. 0.55x	—	-	0.62

\*TCV/WCV are zoom thru type \*\*ø 95mm P-1 screw on type  
Wide attachment and fisheye attachment can be used at WIDE END.  
Number of M.O.D. is at wide end.

### MOUNT ADAPTERS



ACM-21



Original Format	Camera Format	Focal Length Shift
2/3"	1/2"	1.38x
2/3"	1/3"	1.83x
1/2"	1/3"	1.33x

Model	Description
ACM-7B	2/3" lens to adapt to standard 1/2" camera mount
ACM-8	2/3" lens to adapt to Sony 1/2" hot shoe camera mount - power cable from lens connects to camera
ACM-8B	2/3" lens to adapt to Sony 1/2" hot shoe camera mount - power cable from lens connects to ACM
ACM-12	1/2" standard mount lens to adapt to 1/3" standard mount camera ie: JVC HD100/200, Sony HVR-Z7/S270
ACM-17	2/3" lens to adapt to 1/3" standard mount camera ie: JVC, Panasonic and Sony
ACM-19	1/2" Sony hot shoe mount lens to adapt to 1/3" Sony Mount Ie: Sony HVR-Z7/S270
ACM-21	2/3" lens to adapt to 1/2" Sony Sp mount camera Ie: Sony PMW-EX3

# ACCESSORIES: VIDEOCONFERENCING

## LENS CONTROLLERS

Fujinon's lens controllers all feature control of zoom, focus, and iris. The RMD-10 provides basic control of all functions, while the RMD-20 features a rocker-type zoom control. The RMD-30 provides for up to eight preset zoom and focus positions. Accessory cables up to 100 F are available.

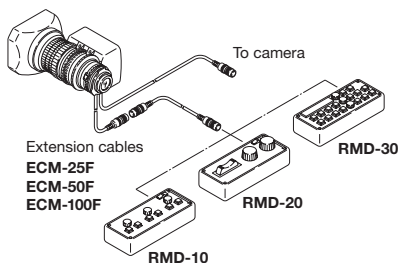

RMD-10

RMD-20

RMD-30

## WIDE/TELE ADAPTERS

Fujinon's wide and tele converters attach easily to the front barrel of the lens to achieve greater wide or tele focal ranges. The 1.6X teleconverter increases the overall range 1.6 times, while the 0.8X wide converter reduces the standard focal length by a factor of 0.8X. Rear-mounted 2X range extenders are available with and without back focus adjustment.



## ELECTRICAL INTERFACE OF 12-PIN CONNECTOR FOR REMOTE CONTROL BOX

- |                                    |                                |
|------------------------------------|--------------------------------|
| 1. Focus Mode Select Signal        | 7. Signal Com. (Reference) +5v |
| 2. Zoom Mode Select Signal         | 8. Focus Control Signal        |
| 3. 0V (Ground)                     | 9. Zoom Control Signal         |
| 4. Iris Local/Camera Select Signal | 10. Iris Mode Select Signal    |
| 5. Iris Control Signal             | 11. +V Out (7.5v)              |
| 6. +12 V Out                       | 12. -V Out (2.5v)              |

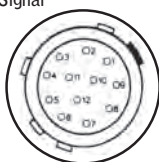

## SS-33A OPTIONAL ACCESSORY CONFIGURATION

Uses Standard ENG Accessories (For model HAs18x7.6B MD only)

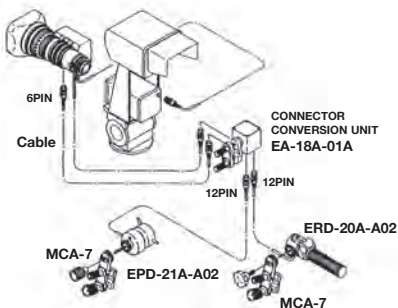

# ACCESSORIES: HD & SD FIELD

Fujinon's anti-vibration system optically compensates for image vibration resulting in stable images even at extreme focal lengths. Two types of **OS-TECH** systems are available: an external anti-vibration adapter, the TS-P for barrel-type lenses, and an internal unit for box-type lenses.

## Image After-Shaking Reduced to a Minimum

The after-shaking phenomenon of images moving after the pan/tilt operation is stopped is characteristic of an anti-vibration device. Fujinon's exclusive algorithm system has reduced the phenomenon to a minimum for a natural-feeling operation.

## Type TS-P Adapt to many Existing ENG Lenses

**OS-TECH** adapter can be quickly attached between most Fujinon ENG lenses and the camera to provide the anti-vibration function. A single adapter provides stabilization for any adaptable lens. In addition to stabilization, the adapter increases the lens magnification by 1.25 times making extreme close-up shots possible with shorter focal length lenses.



The XA101X with internal OS-TECH. (Available in XA76, XA77, XA88, XA99 and XA101)

## Amount of Compensation

At Telephoto End with 2X Extender



Approx. 20% of Image Height Vertical and Horizontal or Vertical Only



TS-P58A



EA-12A-05BD Stabilizer Control with viewfinder indication

The EA-12A-05BA stabilizer controller provides for H or V and H+V plus on/off in a compact controller. This new control includes an LED to indicate on/off in the view finder.

## The Principal of Anti-vibration Device "Optical Stabilized Technology"

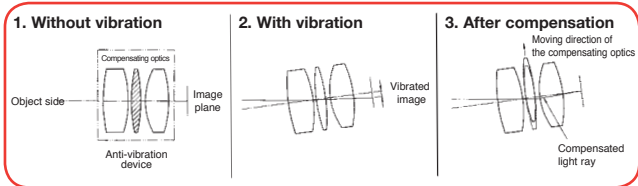

## OS-TECH



Model	TS-P58A
Stabilization System	Optical Shift
Magnification of Focal Length	1.25
Mount	Bayonet Mount (2/3 in. B-type)
Direction of Compensation	Vertical/Horizontal or Vertical Only
Frequency of Compensation	Approx. 1 to 10 Hz
Anti-vibration Range	Approx. 20% of Vertical at Screen
Power Consumption	DC12V, 4.2W (from camera)
Dimensions (L x W x H)	58 x 120 x 150 mm
Mass	0.84kg
Note	Available for most model lenses. Please contact your sales representative for more information.

# ACCESSORIES: HD & SD STUDIO/FIELD

## Studio Lens System

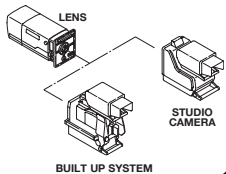

## Field Lens System

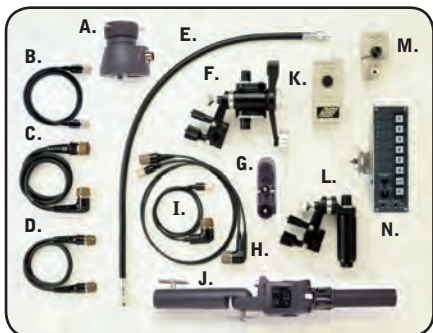
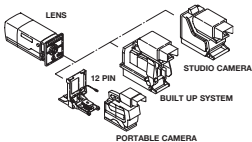

- A. EPD-31A-D02 Focus Demand
- B. ESZ-12 Zoom Demand Cable
- C. ESL-1C Shot Box Cable
- D. ESF-1C Focus Shot Box Cable
- E. BFC-36 Flex Cable
- F. BZH-2A Zoom Handle
- G. MCA-36 Mounting Clamp
- H. EFZ-11E Focus/Zoom Cable
- I. ELZ-11D Zoom Demand Cable
- J. ERD-30A-D01 Zoom Rate Demand
- K. ESM-D51B/D52B Servo Module
- L. BFH-1A Focus Grip
- M. EMM-51B Manual Module
- N. ESB-6A-E12 Shot Box
- EPA-22 Not shown - see below

## DIGI ZOOM DEMAND

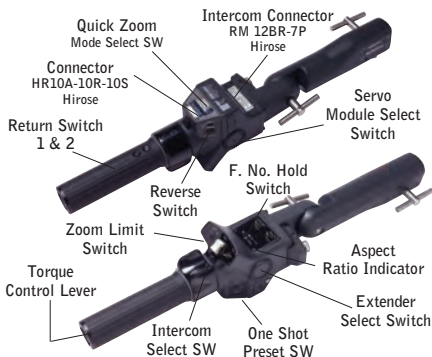

## SERVOS

Digital servos provide precise control of zoom and focus for the most demanding productions.



## ELH\*

Fujinon's convenient ELH bracket allows studio/field lenses to be used with hand-held type cameras.

\*Additional power may be required for servos.

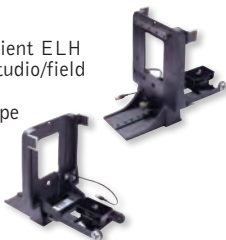

## THREE-MODE FINE FOCUS

By shifting the sensitivity from the wide side to the telephoto side of the focus range, this control provides more precise focusing for studio or sports productions.



## EPA-22

A unique servo focus demand with the look and feel of a manual control.



# ACCESSORIES: HD & SD STUDIO/FIELD

## DIGITAL LENS CONFIGURATION

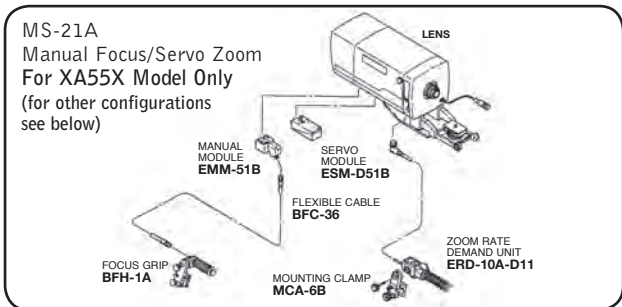

## DIGITAL LENS CONFIGURATION

**MM-21**  
Manual Focus/Manual Zoom

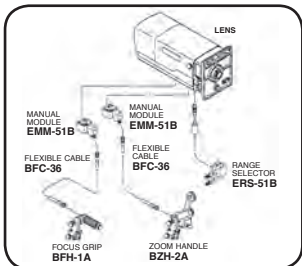

**MS-21D**  
Manual Focus/Servo Zoom

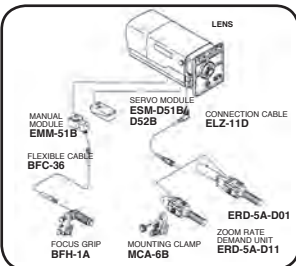

**MS-22D (w/Shot Box)**  
Manual Focus/Servo Zoom

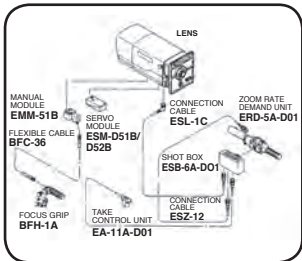

**SS-21D**  
Servo Zoom/Servo Focus

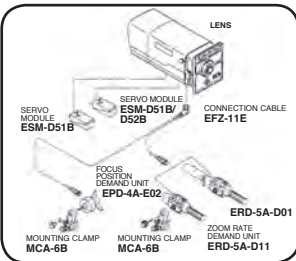

**SS-22D (w/Shot Box)**  
Servo Focus/Servo Zoom

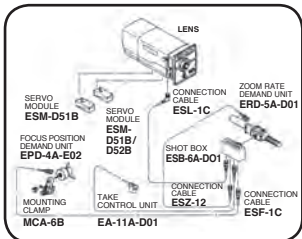

**SS-23D**  
(Shot Box w/Focus Demand)

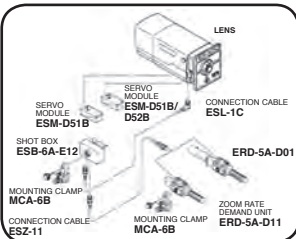

# ACCESSORIES: XA22x7BES

## ACCESSORY OPTIONS

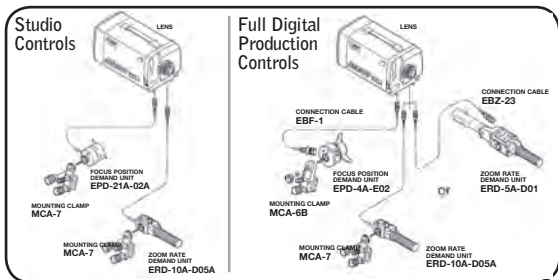

## DIGI ZOOM/ANALOG FOCUS

### Studio Controls



- A. MCA-7 Mounting Clamp    B. EPD-21A-02A Focus Demand    C. ERD-10A-D05A Zoom Demand

## DIGI ZOOM/DIGI FOCUS

### Full Digital Production Controls

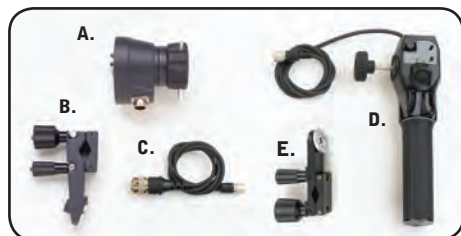

- A. EPD-31A-D02 Digi Focus Demand    C. EBF-1 Focus Cable    E. MCA-7 Mounting Clamp  
 B. MCA-36 Mounting Clamp    D. ERD-10A-D05A Digi Zoom Demand

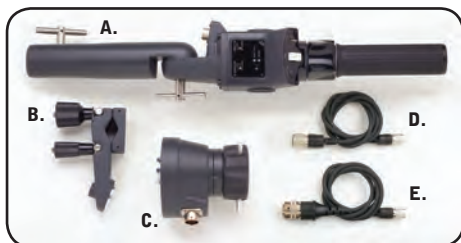

- A. ERD-30A-D01 Digi Zoom Demand    C. EPD-31A-D02 Digi Focus Demand    E. ERP-30A-D01 Focus Cable  
 B. MCA-36 Mounting Clamp    D. EBZ-23 Zoom Cable

XA22x  
ALH-117C-02A











# FUJIFILM

## FUJIFILM NORTH AMERICA CORPORATION

### OPTICAL DEVICES DIVISION

#### New Jersey - SALES & SERVICE CENTER

10 High Point Drive, Wayne, NJ 07470-7434

Tel: (973) 633-5600 Fax: (973) 633-5216

E-mail: lens.sales@fujifilm.com

www.fujinon.com

#### SOUTH EAST

##### Florida - SALES

4101 No. 48th Terrace, Hollywood, FL 33021

Tel: (954) 966-0484

E-mail: knelson@fujifilm.com

##### Georgia - SALES

1426 Towne Lake Parkway, Suite 102, Box 226, Woodstock, GA 30189

Tel: (404) 421-3408

E-mail: steuscher@fujifilm.com

##### Georgia - SERVICE CENTER

1231 Collier Road, Suite G, Atlanta, GA 30318

Tel: (404) 351-1470 Fax: (404) 351-7035

E-mail: sraig@fujifilm.com

#### LATIN AMERICA

##### SALES

Tel: (404) 421-0049

E-mail: wzeferino@fujifilm.com

##### LATIN AMERICA SERVICE & SUPPORT

Tel: (201) 285-9035

E-mail: yito@fujifilm.com

#### MIDWEST

##### Illinois - SALES

655 Deerfield Road, Ste. 100, #206, Deerfield, IL 60015-3241

Tel: (224) 241-0450

E-mail: atanielian@fujifilm.com

#### SOUTH CENTRAL

##### Texas - SALES

Tel: (903) 422-1154

E-mail: dwaddell@fujifilm.com

##### Texas - SERVICE CENTER

18601 LBJ Freeway, Suite 100, Mesquite, TX 75150

Tel: (972) 385-8902 Fax: (972) 392-3251

E-mail: lcoronado@fujifilm.com

#### WEST

##### California - SALES & SERVICE CENTER

W. Bay Business Park, 2621 Manhattan Beach Blvd., Redondo Beach, CA 90278-1604

Tel: (310) 536-0800 Fax: (310) 536-0022

E-mail: jrobinson@fujifilm.com

##### Washington - SALES

P.O. Box 36, Mercer Island, WA 98040

Tel: (206) 422-9057

E-mail: jewing@fujifilm.com

#### CANADA

##### Ontario - SALES

16715 Yonge Street, Unit #12, Suite 203, Newmarket, ON, L3X 1X4, Canada

(905) 898-1382 Fax: (905) 898-3350

E-mail: sdurbacz@fujifilm.com

##### Ontario - SERVICE CENTER

570 Alden Road, Unit #17, Markham, Ontario, Canada, L3R 8N5, Canada

Tel: (905) 947-8800

## FUJIFILM CORPORATION - OPTICAL DEVICE BUSINESS DIVISION

#### Japan

1-324 Uetake, Kita-Ku, Saitama City, Saitama 331-9624 Japan

Tel: 81-48-668-2081 Fax: 81-48-651-8517

www.fujifilm.co.jp

[www.FUJINON.com](http://www.FUJINON.com)



Printed in the USA 4/2014-5M Printed on recycled paper.