

ACCESSORIES

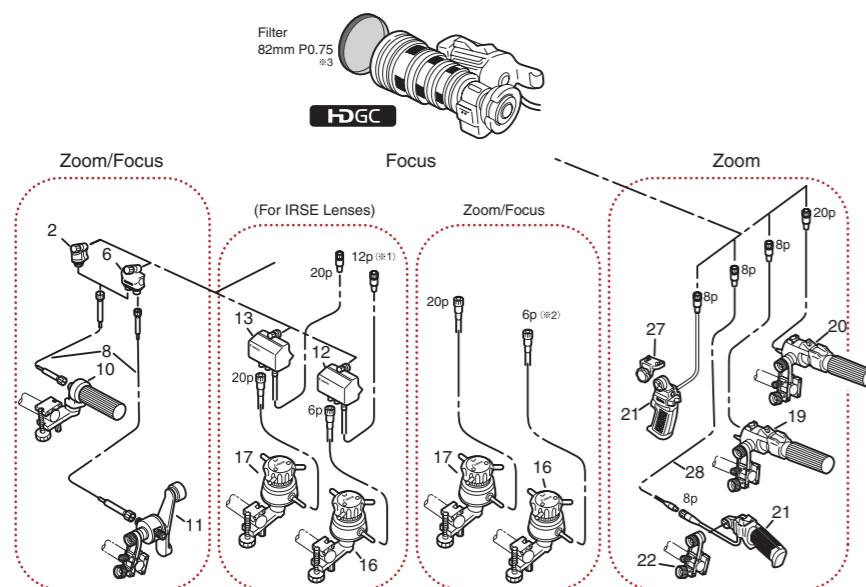

(※1) CC-2012 conversion cable is necessary to connect between IRSE Digital Drive Lens and FPM-420.
 (※2) CC-2006 conversion cable is necessary to connect between IASE Digital Drive Lens and FPD-400.
 (※3) For the optical accessories, the 82mm P0.75 filters are applicable. The filters are to be attached to the lens barrel. (UV/ Sky Light/ Cross/ Snow Cross/ Sunny Cross/ Polarized Light/ Soften/ ND)
 (※4) FPD-400 is not available from Canon stock.

#	Unit	Description
2	FFM-100	Flex Focus Module
6	FFM-200	Flex Dual Module
8	FC-40	Flex Cable
10	FFC-200	Flex Focus Controller
11	FZC-100	Flex Zoom Controller
12	FPM-420	Focus Positional Servo Module
13	FPM-420D	Focus Positional Servo Module
16	FPD-400 ^{※4}	Focus Positional Demand
17	FPD-400D	Focus Positional Demand
19	ZSD-300M	Zoom Demand
20	ZSD-300D	Zoom Servo Demand
21	ZSG-200M	Zoom Servo Grip
22	CR-10	Clamper
27	ZGA-500A/M	Grip Adapter
28	EC-80	Zoom Extension Cable (8P)
32	CC-2006	Conv. Cable (20pM-6pF)
33	CC-2012	Conv. Cable (20pM-12pF)

DIMENSIONS

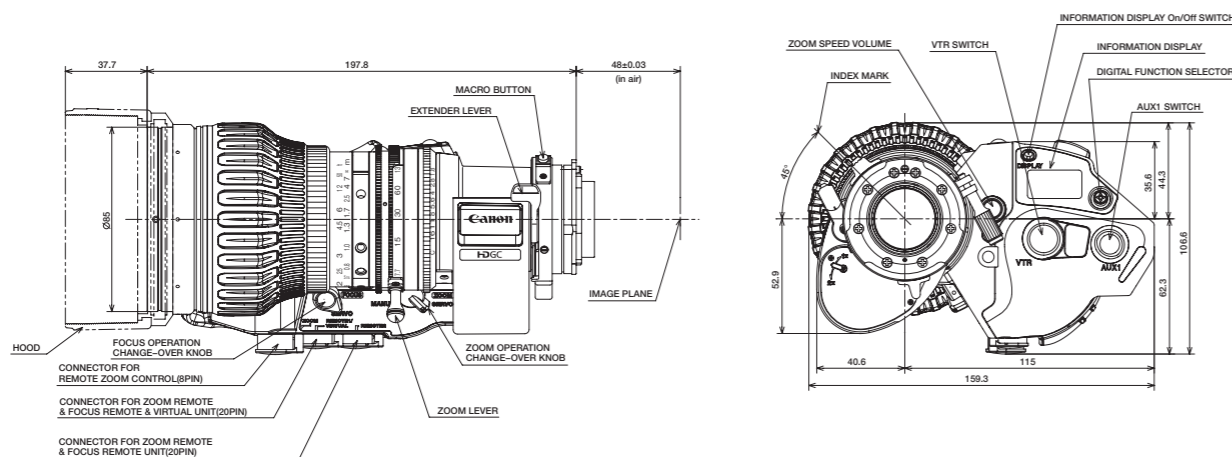

North & South America

Canon U.S.A., Inc.
 Broadcast & Communications Div.(Headquarters)
 65 Challenger Road, Ridgeland Park, NJ 07660
 Tel:(201)807-3300/(800)321-4388
 Fax:(201)807-3333
 Email:bctv@usa.canon.com
<http://www.canonbroadcast.com/>

Chicago
 100 Park Blvd. Itasca, IL 60143
 Tel:(630)250-6236 Fax:(630)250-0399

Atlanta
 5625 Oakbrook Pkwy, Norcross, GA 30093
 Tel:(770)849-7890 Fax:(770)849-7888

Los Angeles
 15955 Alton Parkway Irvine, CA 92618
 Tel:(949)753-4330 Fax:(949)753-4337

Dallas
 3200 Regent Blvd. Irving, TX 75063
 Tel:(972)409-8871 Fax:(972)409-8869

Latin America

Tel:(954)349-6975 Fax:(201)807-3333

Canada

Canon Canada, Inc.
 Broadcast and Communications Div.
 6390 Dixie Road
 Mississauga, Ontario, L5T 1P7, Canada
 Tel:(905)795-2012 Fax:(905)795-2140

Europe/Africa/Middle East

Canon Europa N.V.
 Broadcast and Communications Div.
 Bovenkerkerweg 59-61
 1185 XB Amstelveen
 Tel:+31(0)20-5458905 Fax:+31(0)20-5458203
 Email:tvprod@canon-europe.com
<http://www.canon-europe.com/tv-products>

Australia

Canon Australia Pty. Ltd.
 Optical Products Division
 1 Thomas Holt Drive, North Ryde, NSW 2113,
 Australia
 Tel:+61(0)2-9805-2000 Fax:+61(0)2-9805-2444

China

Canon (China) Co., Ltd.
 Optical Products Division
 15F Jinbao Building No.89 Jinbao Street
 Dongcheng District, Beijing 100005, China
 Tel:86-10-85139999 Fax:86-10-85139902
<http://www.canon.com.cn>

Distributed by

Asia/Japan

Canon Inc.
 (Broadcast Equipment Group)
 23-10, Kiyohara-Kogyo-Danchi, Utsunomiya-shi,
 Tochigi-ken, 321-3298, Japan
 Tel:+81(0)28-667-8669 Fax:+81(0)28-667-8672
<http://www.canon.com/bctv>

Canon <http://www.canon.com/bctv>

Specifications subject to change without notice.

Canon

KJ17ex7.7B

Second Generation HDgc Standard Lens



INNOVATION
 In TV Optics Since 1958

HDGC

KJ17ex7.7B

Canon's Philosophy :

Canon has always developed new technology with four basic philosophies, "High Quality of Picture", "Ease of Operation", "High Specification" and "Minimize Environmental Impact". Canon's HDTV lenses are, so to speak, a compilation of our basic philosophies. Now, Canon reassembles these philosophies in the launching of a second generation HDgc lens series.

Canon's 2nd Generation HDgc Series

The emergence of a new generation of cost-effective HDTV acquisition systems spurred Canon to create a new category of portable lenses to better match the price performance ratio of these cameras. This led to the introduction in 2006 of the new HDgc lens series. Specifically targeted for HD ENG, these lenses retained the optomechanical robustness and ergonomics of the high-end HDxs lens series as well as the same digital drive units. Canon mobilized contemporary design tools and optical materials that facilitated a significant cost reduction while still maintaining an impressive overall HD imaging performance. In recognition of the continuing introduction of new improved 2/3-inch HD acquisition systems and supported by a global experience, Canon is now introducing a second generation HDgc that reflects further design optimizations. The first of these new lenses is the KJ17ex7.7B.



Enhanced Digital Drive Unit

Information Display

Zoom Speed Volume in New Location

New Rubber Grip Support



With the introduction of miniature 16-bit high resolution Rotary Encoder Devices into the enhanced digital drive unit, the lens features;

- Superior precision lens control.
- Precise repeatability in zoom, focus and iris control which supports the creative digital operational functions.
- Simple integration into virtual digital studio systems without any options.
- Dynamic zoom speed range of 0.5 sec. to over a 5 min. super slow zoom.

Moreover, Canon's original Information Display is able to customize the enhanced digital functions much more easily and precisely.

Enhanced Digital Functions

Shuttle Shot

By memorizing any two focal lengths, the Digital Drive can automatically "shuttle" between the two points, moving in either direction.

Frame Preset

An angle of view can be preset in either of two memories and the lens will zoom at the highest speed or in a preset zoom speed to the preset position by pushing a simple button.

Speed Preset

A specific zoom speed can be preset in memory and it is possible to repeat the zoom speed as often as you like by pushing a simple button.

Cost Effective HDTV Standard Lens

Short M.O.D. 0.6m (10mm with Macro)

Newly Designed Ergonomic Drive Unit

New Rubber Roller

2.0x Extender

Dynamic Zoom Speed Range (0.5sec-5min from wide end to tele end)

Newly Designed Hood Cover

Exceptional High Optical Performance

High MTF, Minimized Chromatic Aberrations and Countermeasures against Ghosting and Flares



Main Features

Powerful ENG Lens for Cost Effective HD Productions

The KJ17ex7.7B is specifically designed for users whose foremost priority is a lens that delivers a generous range of focal lengths combined with a wide field of view in a lightweight mobile package. The lens design is a fine compromise between the demands for ruggedness and mobility in a handheld camera system and the high imaging performance requirements for HD News and lower budget HD productions. An important aspect of this lens is the cost optimized design concept. Customer recommendations combined with evolving optical design strategies and materials produced a new definition in price performance ratio for HD ENG acquisition systems that guided the design of the new KJ17ex7.7B.



Improved Optical Performance

Compared to its predecessor KJ16ex7.7B lens, the optical performance of the KJ17ex7.7B has been improved on a number of fronts. Utilizing special optical materials such as "Fluorite" and "Hi-UD" (high index ultra low dispersion) glasses, most of the lens elements and optical layout were redesigned using Canon's advanced computer-aided techniques to achieve a new level of optimization. Of particular significance are improvements in monochromatic and chromatic aberrations, producing enhanced image sharpness at picture center and picture extremities. New aspheric lens element designs have helped to further diminish geometric distortion and flare.

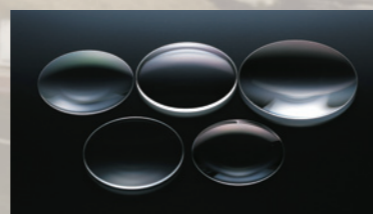

Specially designed optical lens elements

Improved Operability and Reduced Operator Fatigue

Coupled with innovations in optical performance, is a totally new design of the digital drive unit. Refined by long-term market research and worldwide experience, Canon utilized the latest in 3D CAD-CAM design to significantly improve the human tactile interface to the control of zoom, iris, and focus. Canon's research produced the following physical enhancements:



Reduced Physical Stress

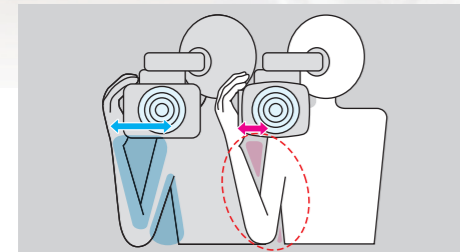

By reducing the width of the drive unit, the palm of the camera operator's hand is positioned closer to the optical axis, thus reducing the degree of arm bend which in turn lessens physical stress during prolonged shooting.

Improved Ease of Operation

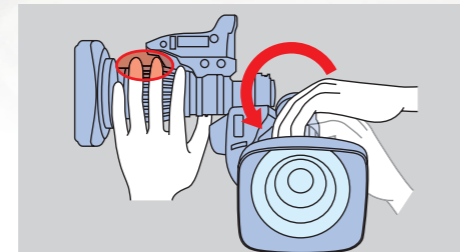

The spacing between the focus ring and drive unit has been opened to avoid accidental interference with the drive unit while manipulating the focus control.

Ergonomic Design

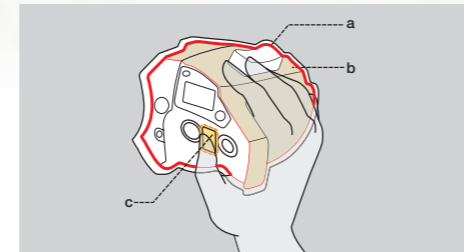

The size and curvature size have been optimized to more comfortably fit in the palm of the operator's hand (a). Newly developed coatings improve the tactile interface between the user and the drive unit (b) together with the new Rubber Grip Support (c).



SPECIFICATIONS KJ17ex7.7B

	16:9		4:3	
	1.0x	2.0x	1.0x	2.0x
Built-in extender	1.0x	2.0x	1.0x	2.0x
Zoom Ratio	17x			
Range of Focal Length	7.7-131mm	15.4-262mm	7.7-131mm	15.4-262mm
Maximum Relative Aperture	1:1.8 at 7.7-102.5mm 1:2.3 at 131mm	1:3.6 at 15.4-205.0mm 1:4.6 at 262mm	1:1.8 at 7.7-102.5mm 1:2.3 at 131mm	1:3.6 at 15.4-205.0mm 1:4.6 at 262mm
Angular Field of View	63.9°×38.6° at 7.7mm 4.20°×2.36° at 131mm	34.6°×19.9° at 15.4mm 2.10°×1.18° at 262mm	59.5°×46.4° at 7.7mm 3.85°×2.89° at 131mm	31.9°×24.2° at 15.4mm 1.92°×1.44° at 262mm
Minimum Object Distance (M.O.D)	0.6m(10mm with Macro)			
Object Dimensions at M.O.D	68.5×38.5cm at 7.7mm 4.2×2.4cm at 131mm	34.3×19.3cm at 15.4mm 2.1×1.2cm at 262mm	63.1×47.3cm at 7.7mm 3.8×2.9cm at 131mm	31.6×23.7cm at 15.4mm 1.9×1.5cm at 262mm
Approx. Size	W×H×L=159.3×106.6×197.8mm			
Approx. Mass (IRSE/IASE)	1.48Kg(3.26lbs)/1.56Kg(3.44lbs)			

KJ17ex7.7B IRSE.....Zoom: Servo / Manual Focus: Manual
KJ17ex7.7B IASE.....Zoom: Servo / Manual Focus: Servo / Manual