



**VRzero eMagnum Bundle**  
**Setup Guide**

# Thank You for Choosing Ross

You've made a great choice. We expect you will be very happy with your purchase of Ross Technology. Our mission is to:

1. Provide a Superior Customer Experience
  - offer the best product quality and support
2. Make Cool Practical Technology
  - develop great products that customers love

Ross has become well known for the Ross Video Code of Ethics. It guides our interactions and empowers our employees. I hope you enjoy reading it below.

If anything at all with your Ross experience does not live up to your expectations be sure to reach out to us at [solutions@rossvideo.com](mailto:solutions@rossvideo.com).



David Ross  
CEO, Ross Video  
[dross@rossvideo.com](mailto:dross@rossvideo.com)

## Ross Video Code of Ethics

Any company is the sum total of the people that make things happen. At Ross, our employees are a special group. Our employees truly care about doing a great job and delivering a high quality customer experience every day. This code of ethics hangs on the wall of all Ross Video locations to guide our behavior:

1. We will always act in our customers' best interest.
2. We will do our best to understand our customers' requirements.
3. We will not ship crap.
4. We will be great to work with.
5. We will do something extra for our customers, as an apology, when something big goes wrong and it's our fault.
6. We will keep our promises.
7. We will treat the competition with respect.
8. We will cooperate with and help other friendly companies.
9. We will go above and beyond in times of crisis. *If there's no one to authorize the required action in times of company or customer crisis - do what you know in your heart is right. (You may rent helicopters if necessary.)*

# VRzero eMagnum Bundle Setup Guide

- Ross Part Number: **5120DR-008-01**.
- Publication Date: March 6, 2020. Printed in Canada.

## Copyright

©2020 Ross Video Limited, Ross®, and any related marks are trademarks or registered trademarks of Ross Video Limited. All other trademarks are the property of their respective companies. PATENTS ISSUED and PENDING. All rights reserved. No part of this publication may be reproduced, stored in a retrieval system, or transmitted in any form or by any means, mechanical, photocopying, recording or otherwise, without the prior written permission of Ross Video. While every precaution has been taken in the preparation of this document, Ross Video assumes no responsibility for errors or omissions. Neither is any liability assumed for damages resulting from the use of the information contained herein.

## Patents

Ross Video products are protected by patent numbers US 7,034,886; US 7,508,455; US 7,602,446; US 7,802,802 B2; US 7,834,886; US 7,914,332; US 8,307,284; US 8,407,374 B2; US 8,499,019 B2; US 8,519,949 B2; US 8,743,292 B2; GB 2,419,119 B; GB 2,447,380 B. Other patents pending.

## Company Address



### **Ross Video Limited**

8 John Street  
Iroquois, Ontario  
Canada, K0E 1K0

### **Ross Video Incorporated**

P.O. Box 880  
Ogdensburg, New York  
USA 13669-0880

General Business Office: (+1) 613 • 652 • 4886

Fax: (+1) 613 • 652 • 4425

Toll Free Technical Support: 1-844-652-0645 (North America)

+800 1005 0100 (International)

Technical Support: (+1) 613 • 652 • 4886

After Hours Emergency: (+1) 613 • 349 • 0006

E-mail (Technical Support): [techsupport@rossvideo.com](mailto:techsupport@rossvideo.com)

E-mail (General Information): [solutions@rossvideo.com](mailto:solutions@rossvideo.com)

Website: <http://www.rossvideo.com>



# Contents

<b>Welcome</b>	<b>7</b>
Text Formatting Conventions .....	7
Contacting Technical Support .....	7
Important Safety Message .....	8
<b>Introducing VRzero eMagnum</b>	<b>9</b>
<b>Assembly and Cabling</b>	<b>11</b>
Before You Begin .....	11
Mount the eMagnum Fluid Head, and Attach Pan Bars .....	11
Mount the VRzero Module .....	14
Cable the System .....	18
<b>Configuration</b>	<b>21</b>
Accessing the Configuration Application .....	21
Setting the IP Address .....	22
Specifying Data Destination Addresses .....	25
Configuring Destination Systems .....	27
<b>Troubleshooting</b>	<b>29</b>
Symptoms and Possible Causes .....	29
Finding the IP Address of a VRzero Module .....	30
Restoring the Ross Video Default Configuration .....	31
<b>Technical Specifications</b>	<b>37</b>



# Welcome

This document is the Setup Guide for the VRzero eMagnum Bundle, designed for use in Virtual Studios or Augmented Reality applications.

This Setup Guide describes how to assemble and configure your tracking system. It also provides technical specifications and troubleshooting information.

An electronic PDF copy of this Setup Guide is available online at [www.rossvideo.com/support/product-documentation/vrzero](http://www.rossvideo.com/support/product-documentation/vrzero). Free registration is required.

This section describes text formatting conventions used in this Setup Guide and provides information about how to contact Ross Video Technical Support.

## Text Formatting Conventions

Special text formats are used in this Setup Guide to identify parts of the user interface, text that a user must enter, or a sequence of menus and sub-menus that must be followed to reach a particular command.

Text Format	Meaning
<b>Bold text</b>	Bold text is used to identify a user interface element such as a dialog box, menu item, or button. For example: On the <b>Main Menu</b> , click <b>Network Settings</b> .
Courier text	Courier text is used to identify text that a user must type. For example: In the address bar, type localhost and press <b>Enter</b> .
<i>Italic text</i>	Italic text is used to identify the titles of referenced guides, manuals, or documents. For example: For more information, see the <i>VRzero eMagnum Bundle Setup Guide</i> .
>	Menu arrows are used in procedures to identify a sequence of menu items that you must follow. For example, if a step reads “ <b>Operating Settings &gt; Port1</b> ”, you would tap the <b>Operating Settings</b> node and then tap <b>Port1</b> .

## Contacting Technical Support

At Ross Video, we take pride in the quality of our products, but if problems occur, help is as close as the nearest telephone.

Our 24-hour Hot Line service ensures you have access to technical expertise around the clock. After-sales service and technical support is provided directly by Ross Video personnel. During business hours (Eastern time), technical support personnel are available by telephone any time. After hours and on weekends, a direct emergency technical support phone line is available. If the technical support person who is on call does not answer this line immediately, a voice message can be left and the call will be returned shortly. This team of highly trained staff is available to react to any problem and to do whatever is necessary to ensure customer satisfaction.

- **Toll Free Technical Support:** 1-844-652-0645 (North America), or +800 1005 0100 (International)
- **Technical Support:** (+1) 613-652-4886
- **After Hours Emergency:** (+1) 613-349-0006
- **E-mail for Technical Support:** [techsupport@rossvideo.com](mailto:techsupport@rossvideo.com)
- **E-mail for General Information:** [solutions@rossvideo.com](mailto:solutions@rossvideo.com)
- **Website:** <http://www.rossvideo.com>





# Introducing VRzero eMagnum

The VRzero eMagnum Bundle is designed to introduce virtual or augmented reality in dynamic environments where a manually operated camera is the best option. It provides stable and accurate tracking data over an IP data stream that is easily integrated with a complete Ross Virtual Solution, or third party render engine.

The system consists of an encoded Cartoni eMagnum fluid head, plus Ross Video's VRzero module mounted on the fluid head's pan bars. The eMagnum fluid head is typically mounted on a tripod (available from Ross Video). A video camera with an encoded lens (zoom and focus) is mounted on the fluid head.

The eMagnum fluid head has built-in absolute pan and tilt encoders. The VRzero module receives raw encoder counts from the fluid head and the lens encoders in real time, and transmits the data over your IP network to up to four destination systems. The destinations are typically Virtual Camera Controller (VCC) applications such as Ross Video UX VCC.

The VRzero module accepts a video reference (genlock/sync) signal to ensure accurate synchronization of Virtual Studio / Augmented Reality (VS/AR) tracking data.

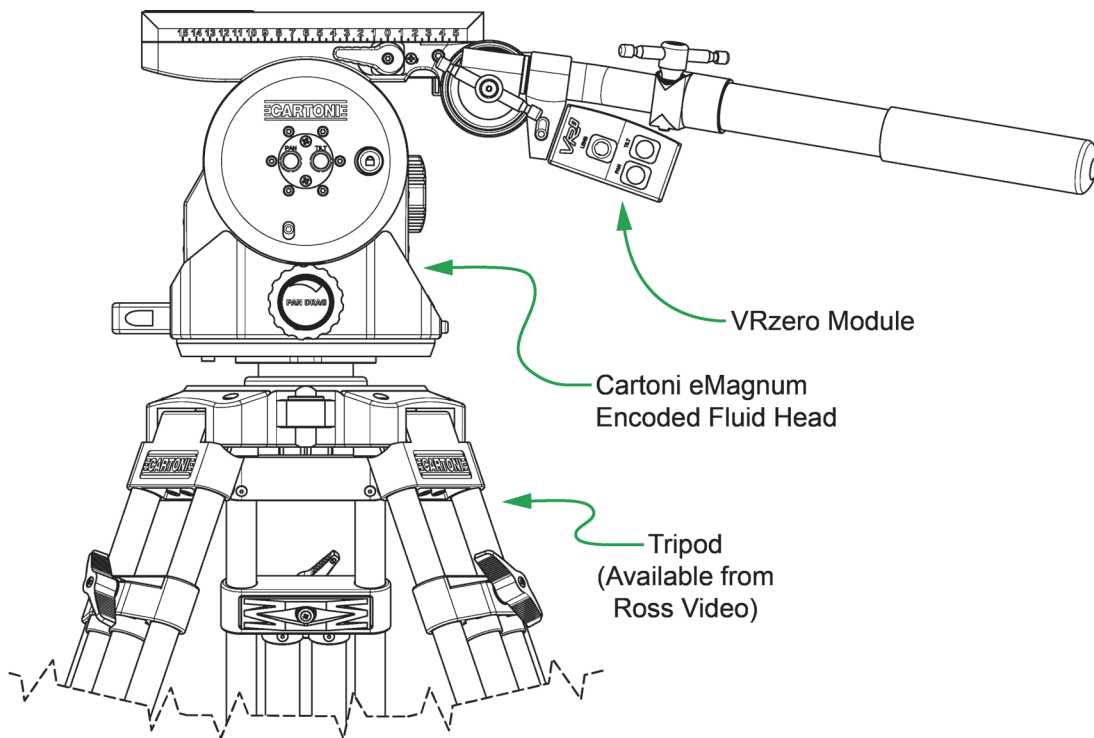

**Figure 2.1** - The VRzero eMagnum Bundle, Plus Tripod (cables omitted for clarity)



# Assembly and Cabling

This section explains how to assemble and cable the components of the VRzero eMagnum Bundle.

Topics in this section include the following:

- “**Before You Begin**” on page 11
- “**Mount the eMagnum Fluid Head, and Attach Pan Bars**” on page 11
- “**Mount the VRzero Module**” on page 14
- “**Cable the System**” on page 18

After you assemble and cable the components, you must configure the VRzero module. For more information, see “**Configuration**” on page 21.

## Before You Begin

Before you begin, ensure that you have the required tools:

- 3mm hex key (also known as a hexagonal wrench, or Allen key)
- 4mm hex key

## Mount the eMagnum Fluid Head, and Attach Pan Bars

These steps illustrate how to mount the eMagnum fluid head to a tripod recommended and sold by Ross Video (product code **RRB-EMAG-TRI**). The fluid head can mount to any Mitchell flat base heavy duty tripod.

### To mount and level the eMagnum fluid head:

1. Unpack the tripod and set it up.
2. Unpack the eMagnum fluid head and mount it to the tripod.
3. Level the head, referring to the built-in bubble level (see **Figure 3.1**).

The head must be level to ensure that pan motion is perfectly horizontal.

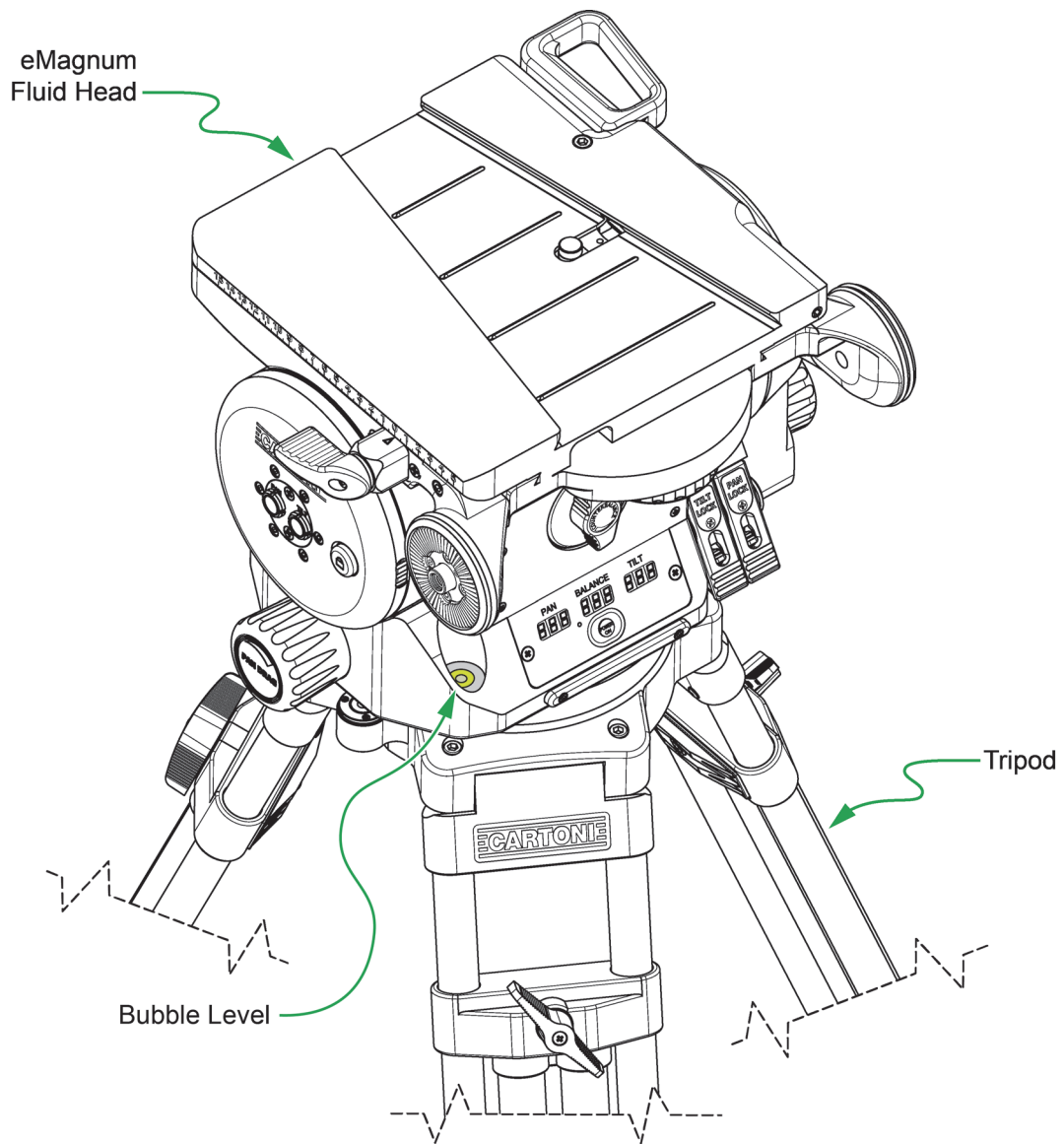

**Figure 3.1 - Mounting and leveling the eMagnum fluid head**

**To attach pan bars to the eMagnum fluid head:**

1. Unpack the two pan bars (right and left) and determine which is which (see **Figure 3.2**).

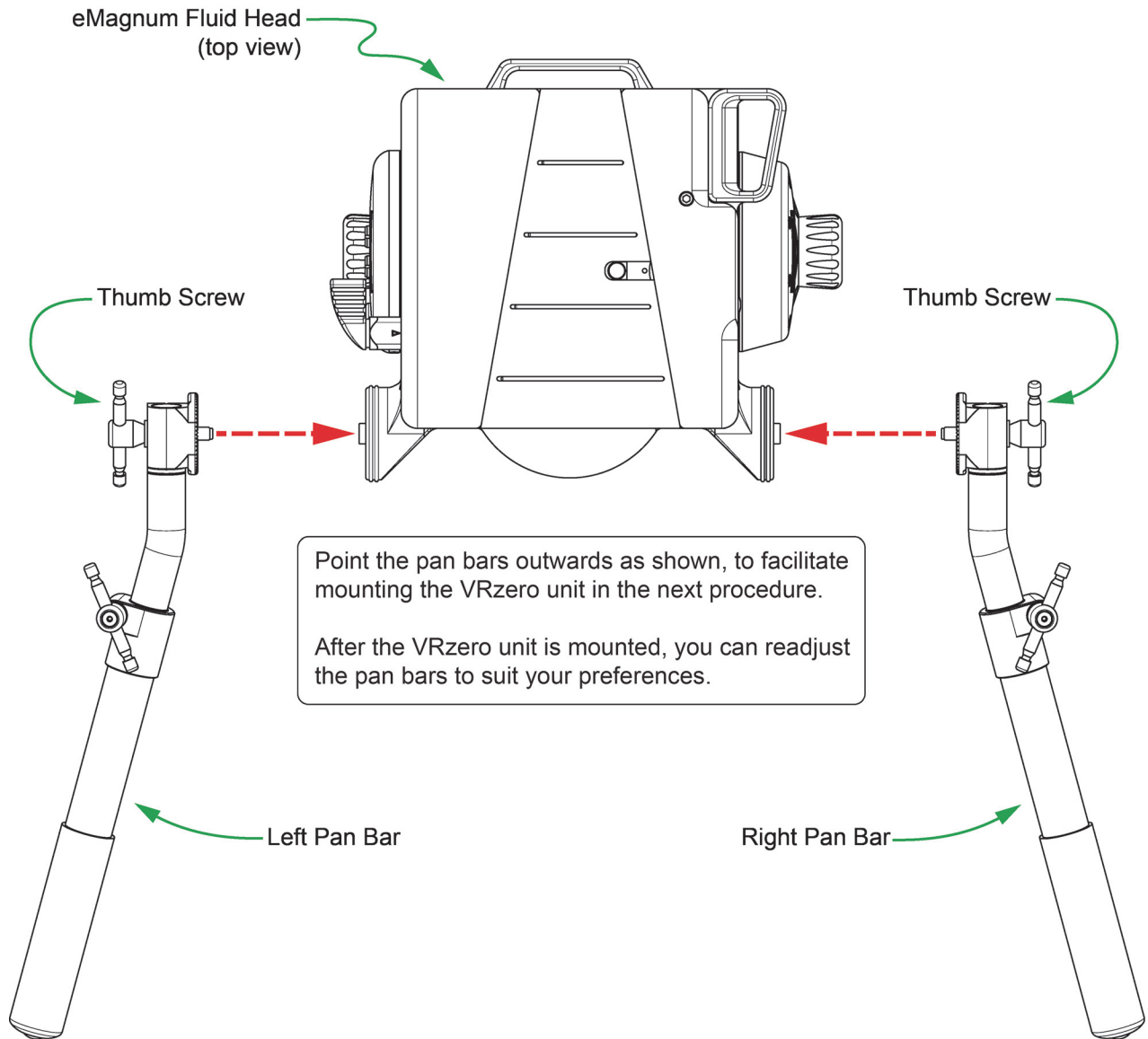

**Figure 3.2** - Attaching the Pan Bars to the eMagnum Fluid Head (view from above)

2. For each pan bar:
  - a. Align the pan bar so it extends horizontally from the eMagnum fluid head and points outwards (see **Figure 3.2**).

**Tip:** Pointing the pan bars outwards facilitates mounting of the VRzero module in the next procedure. After the module is mounted, you can readjust the pan bars to suit your preferences.
  - b. Attach the pan bar to the eMagnum fluid head, and secure it using the thumb screws.

**Tip:** To fully engage the rosette connectors, wiggle the pan bar slightly as it becomes snug.

## Mount the VRzero Module

The VRzero module mounts between the pan bars of the eMagnum fluid head.

### To mount the VRzero module:

1. Unpack the VRzero module and its mounting bracket (see **Figure 3.3**).

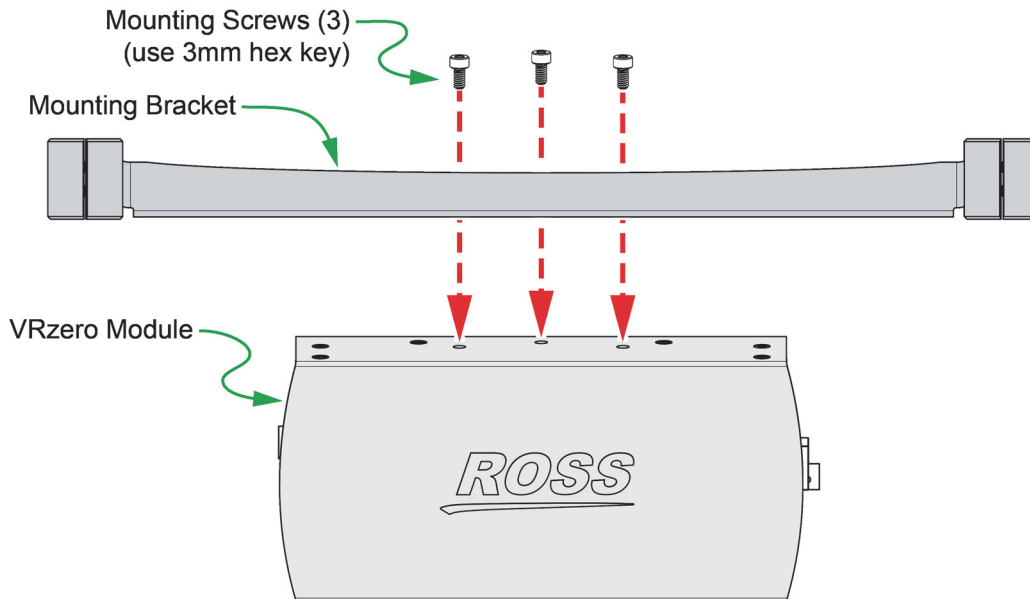

**Figure 3.3** - Attaching the Mounting Bracket to the VRzero Module

2. Fasten the bracket to the VRzero module (see **Figure 3.3**):
  - a. Using a 3mm hex key, remove the three mounting screws from the VRzero module.
  - b. Align the holes in the bracket to the screw holes on the VRzero module.
  - c. Fasten the bracket to the VRzero module, using the three screws you removed in **Step 2a**.
3. Mount the VRzero module on the pan bars:
  - a. Using a 4mm hex key, remove both side clamps from the mounting bracket (see **Figure 3.4**).

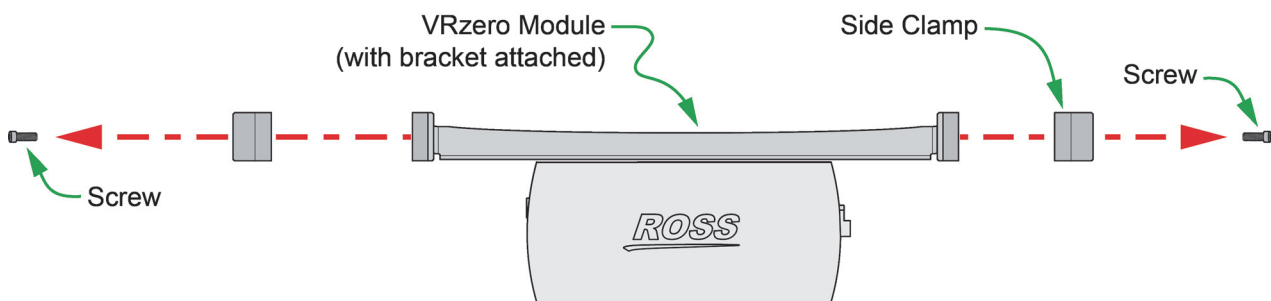

**Figure 3.4** - Removing Side Clamps

- b. Slide the VRzero module between the pan bars, positioning it no more than 1/4" (6mm) from where the pan bars meet the eMagnum fluid head (see **Figure 3.5**).

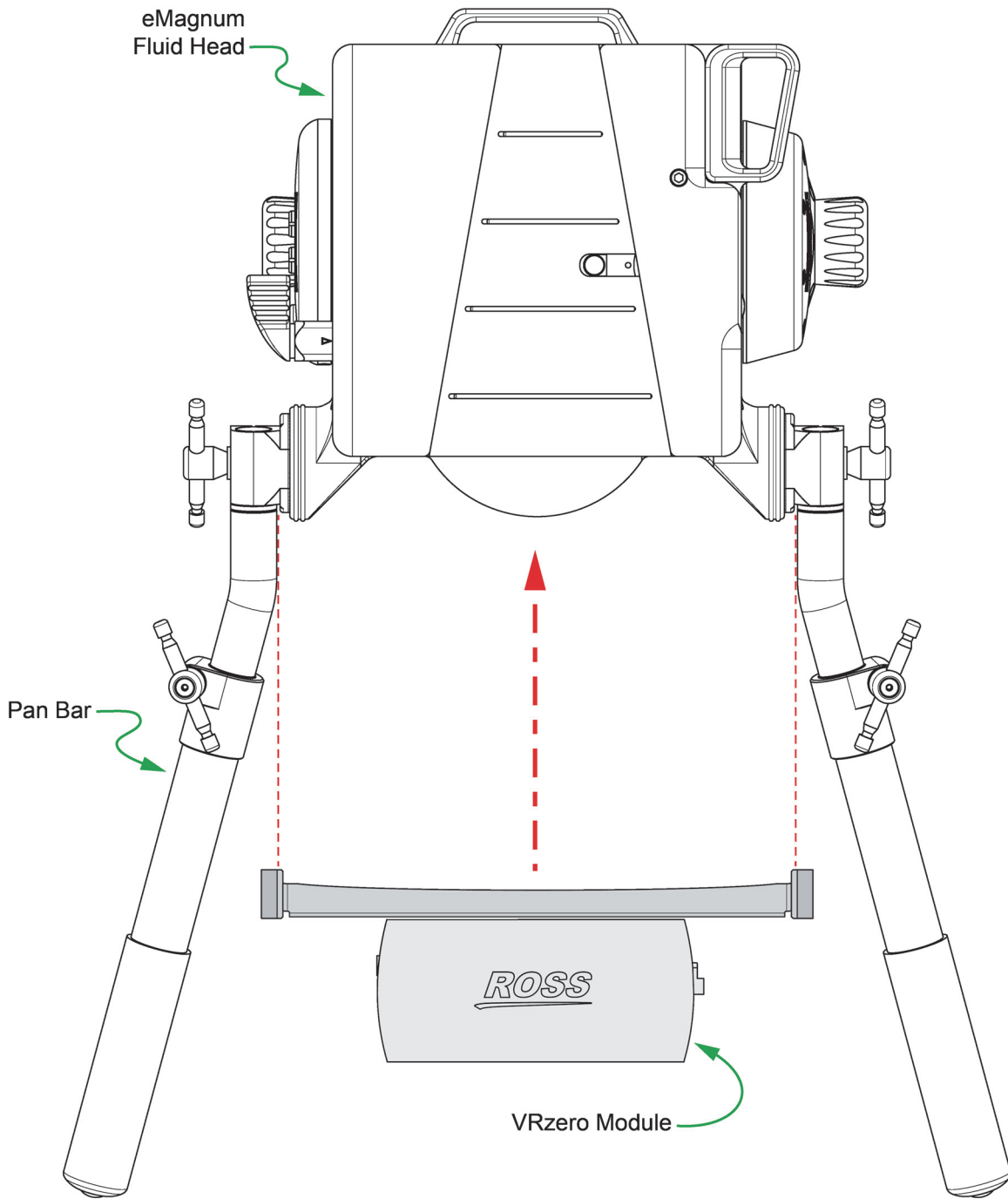

**Figure 3.5** - Sliding the VRzero Module onto the Pan Bars

- c. Using a 4mm hex key, reattach both side clamps so they clamp the pan bars loosely.

Do not tighten the side clamp screws completely yet. Leave the side clamps slightly loose to facilitate adjustment of the pan bars.

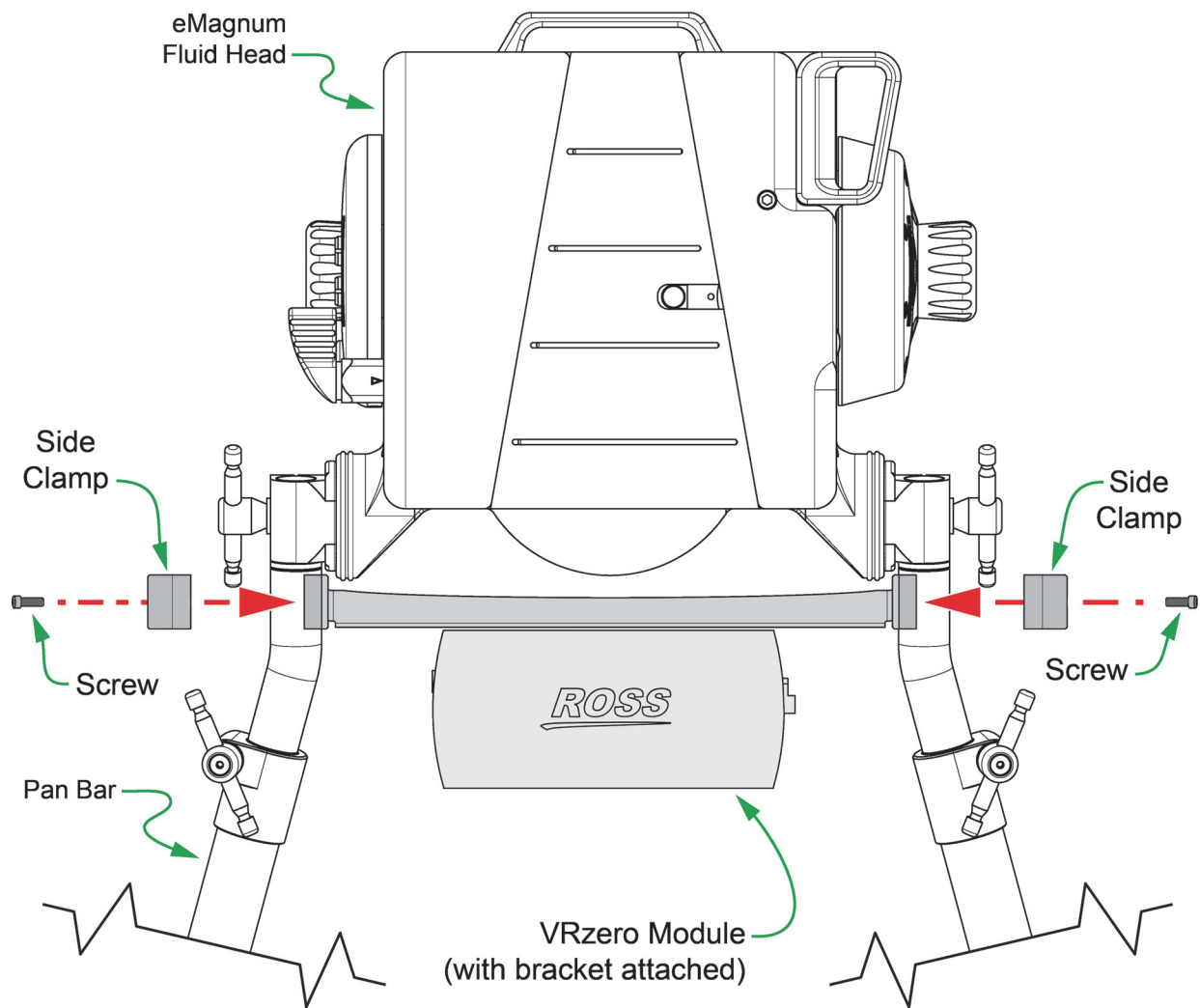

**Figure 3.6 - Reattaching the Side Clamps**

- d.** Adjust the direction that the pan bars point, to suit your preferences (see **Figure 3.7**):
- Loosen both rotation thumb screws slightly and then rotate the pan bars to adjust which way they point.
  - Re-tighten both rotation thumb screws.
  - Using a 4mm hex key, tighten both side clamps so they clamp the pan bars firmly. Do not over-tighten.



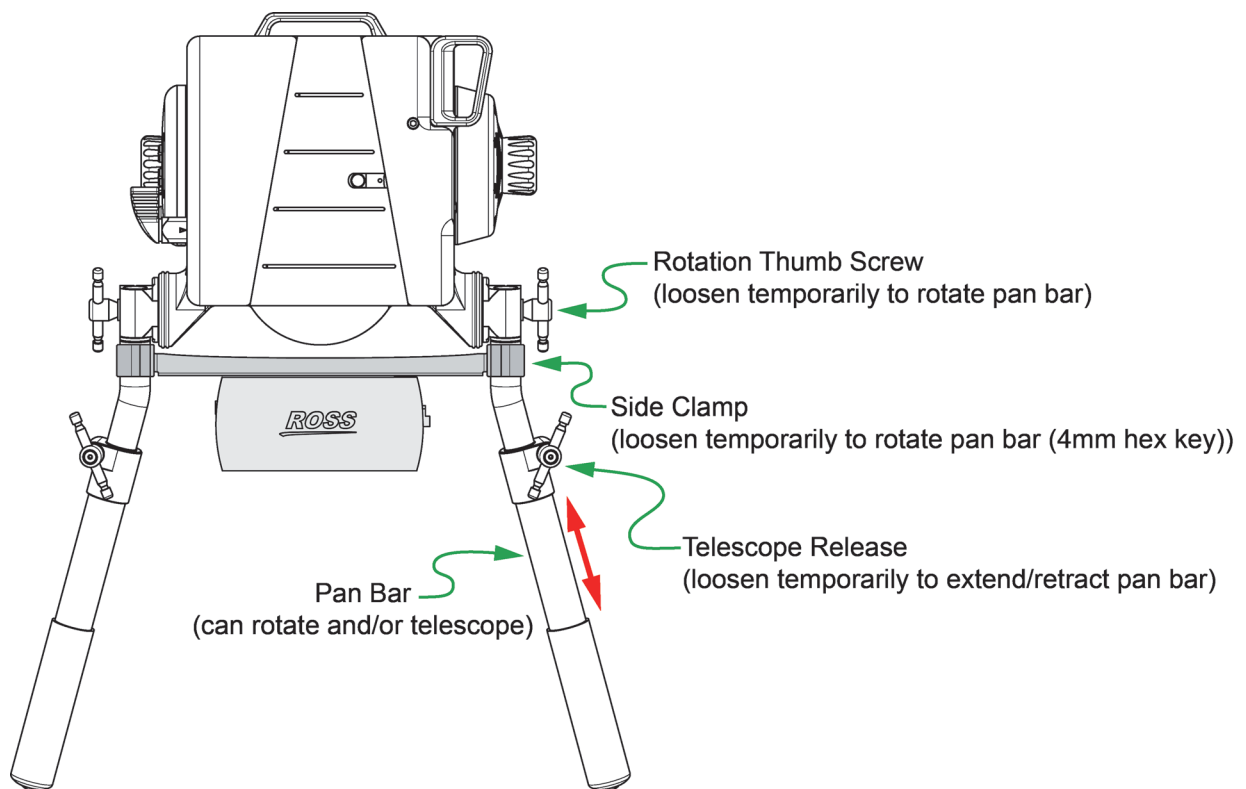

**Figure 3.7** - Adjusting the Pan Bars (rotate and/or extend/retract)

- e. Adjust the length of each pan bar, to suit your preferences (see **Figure 3.7**):
- Loosen the telescope release.
  - Slide the end section of the pan bar in/out to the desired position.
  - Re-tighten the telescope release.

## Cable the System

Before you cable the system, mount the camera and lens on the eMagnum fluid head. You can also adjust the fluid head's counterbalance, tilt drag, and pan drag settings as desired.

**Figure 3.8** shows the connectors on either end of the VRzero module. The steps in this section describe how to connect cables to the module.

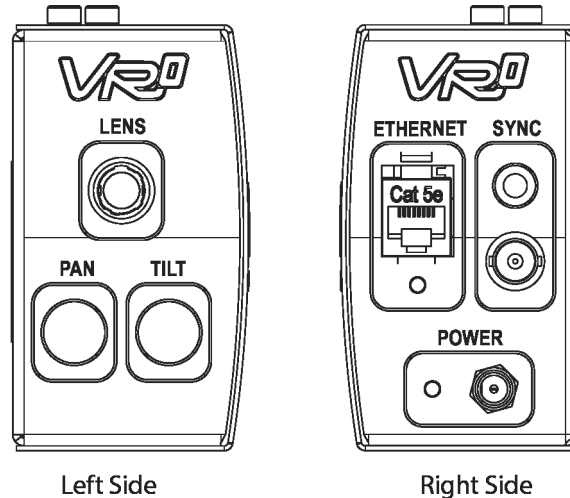
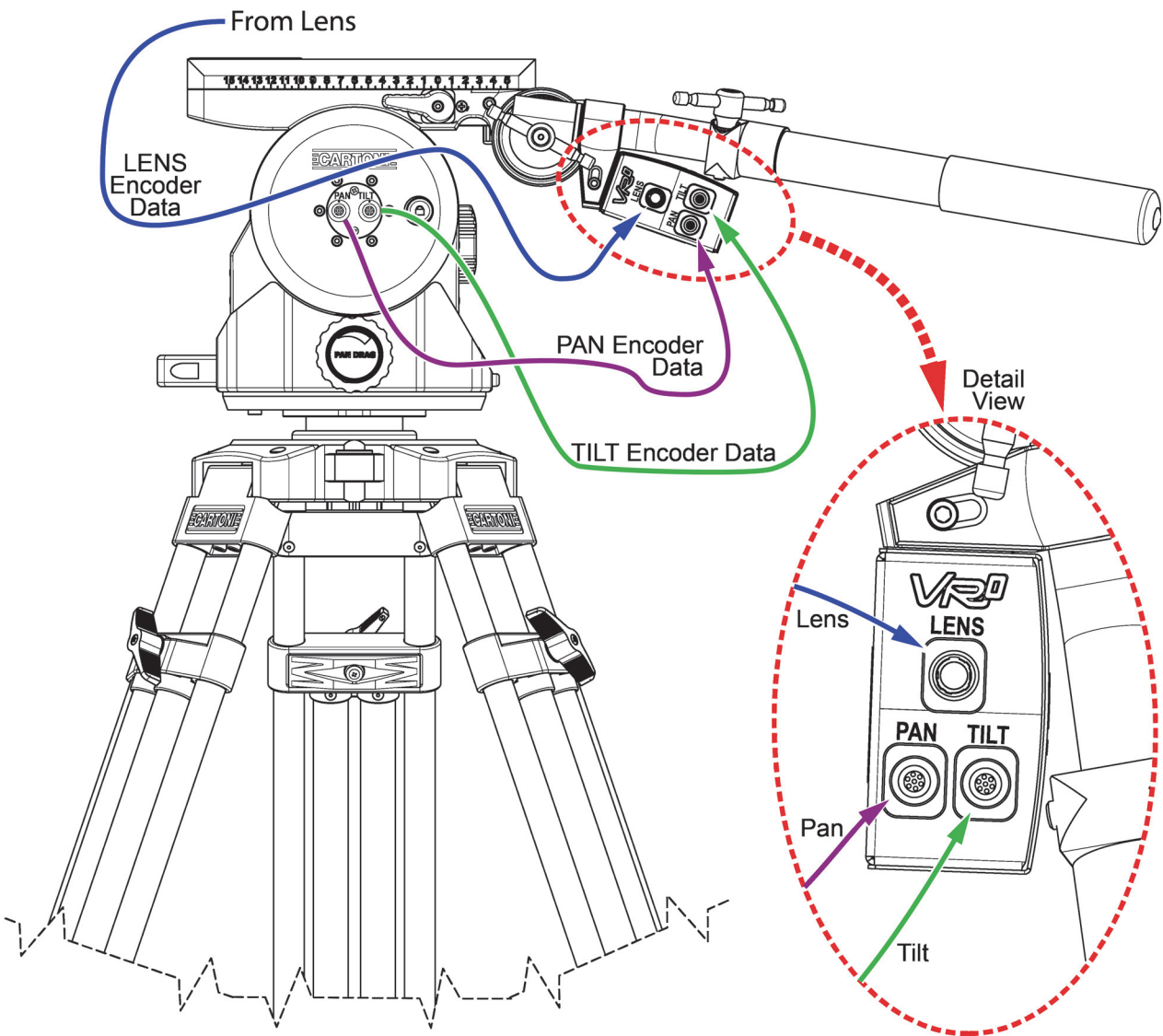

**Figure 3.8** - Connections on the VRzero Module

### To cable the system:

1. Connect the encoder data cables (see **Figure 3.9**):
  - a. Connect the **PAN** and **TILT** encoder data cables from the eMagnum fluid head to the VRzero module.

**Tip:** The **PAN** and **TILT** encoder data cables are identical. They are approximately 25" (64cm) long and each has a tag showing part number **5120CR-305-xx**. In **Figure 3.9**, the **PAN** data cable is shown as purple, and the **TILT** data cable is shown as green.



**Figure 3.9 - Connecting Encoder Data Cables (PAN, TILT, and LENS)**

- b.** Connect the **LENS** encoder data cable from the lens to the VRzero module. In **Figure 3.9**, the **LENS** data cable is shown as blue.

Use the correct lens encoder cable for your lens type:

- For Canon lenses, use Ross Video cable number **900-212-xx**.
- For Fujinon lenses, use Ross Video cable number **5100CR-029-xx**.

**Tip:** Both types of lens encoder data cable are included in the VRzero eMagnum Bundle.

- 2.** Connect the video reference (genlock/sync) signal cable (not included) to the **SYNC** BNC connector on the VRzero module (see **Figure 3.10**).

The **SYNC** LED glows green when the module is connected to a video reference signal.

**Note:** Tri-level and black burst formats are supported. The VRzero module receives video reference signal only; it does not generate the signal.

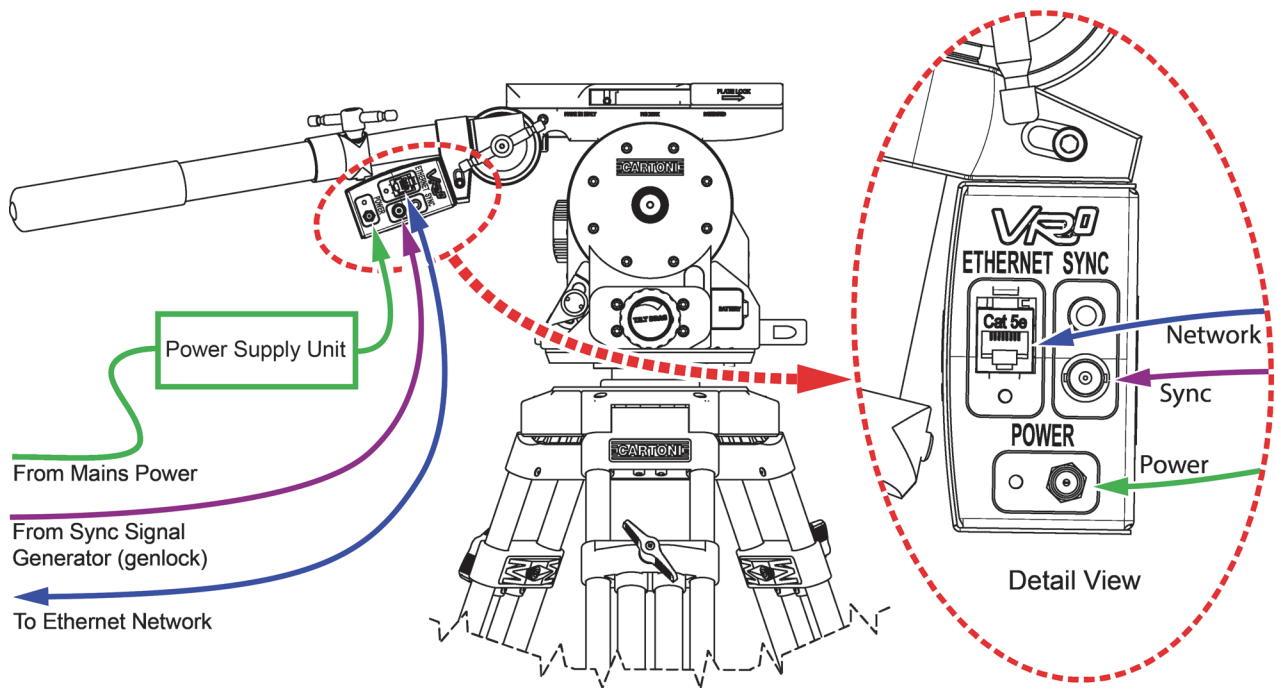

**Figure 3.10 - Connecting Sync, Network, and Power Cables**

3. Connect an **ETHERNET** cable (CAT5E or better, not included) between the VRzero module and the network.

**Note:** The VRzero module must be on the same network as all destination systems that require the tracking data, such as a Virtual Camera Control (VCC) system.

4. Connect power cables to the camera and lens as required.

**IMPORTANT:** When you use the VRzero module, you must turn on the camera and lens before applying power to the module. If the camera and lens are not powered first, the VRzero module may not be able to relay lens encoder data (zoom and focus).

5. Connect the VRzero module's power supply unit to the module's **Power** input connector, and then to a standard electrical outlet.

**Note:** There is no power switch. When you apply power, the VRzero module turns on. The Power LED glows red while the module is initializing, and then turns green.

**Tip:** The power plug has a threaded sleeve to secure it to the **Power** connector on the VRzero module. Use of this threaded sleeve is optional.

# Configuration

This section describes how to configure VRzero eMagnum Bundle components to suit your application.

Before you begin, obtain the following information:

- IP address and port number of each Virtual Camera Controller (VCC) or other external system that will receive encoder data (four destinations maximum).
- IP address of the VRzero module.

**Tip:** If you do not know the IP address of the VRzero module, steps in this section will help you obtain it.

Topics in this section include:

- “**Accessing the Configuration Application**” on page 21
- “**Setting the IP Address**” on page 22
- “**Specifying Data Destination Addresses**” on page 25
- “**Configuring Destination Systems**” on page 27

## Accessing the Configuration Application

Follow the procedures in this section to configure the VRzero module, using the **MOXA NPort web console** application.

This section describes how to connect a computer directly to the VRzero module, and how to open the NPort web console.

### To access the NPort web console:

1. Plug in the VRzero module to turn it on.  
The LED beside the power connector briefly turns red, and then green.
2. Connect an Ethernet cable (CAT5e or better) between the VRzero module and your computer.
3. Open a web browser.
4. In the address bar of the web browser, type the IP address of the VRzero module and then press **Enter**.

If you do not know the IP address, do one of the following:

- Try the factory default IP address, which is 192.168.127.254.
- Check whether the IP address is written on the back of the VRzero module. The label on the back of the module has a blank area intended for recording the IP address (see **Figure 4.1**).

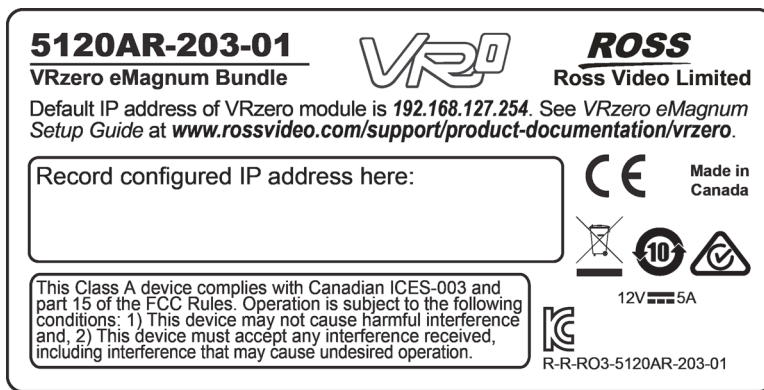

Figure 4.1 - Label on the Back of the VRzero Module, with Space to Record the IP Address

- Download and install the **NPort Search Utility**, which can detect the IP address. For more information, see “Finding the IP Address of a VRzero Module” on page 30.

The NPort web console application appears (see Figure 4.2).

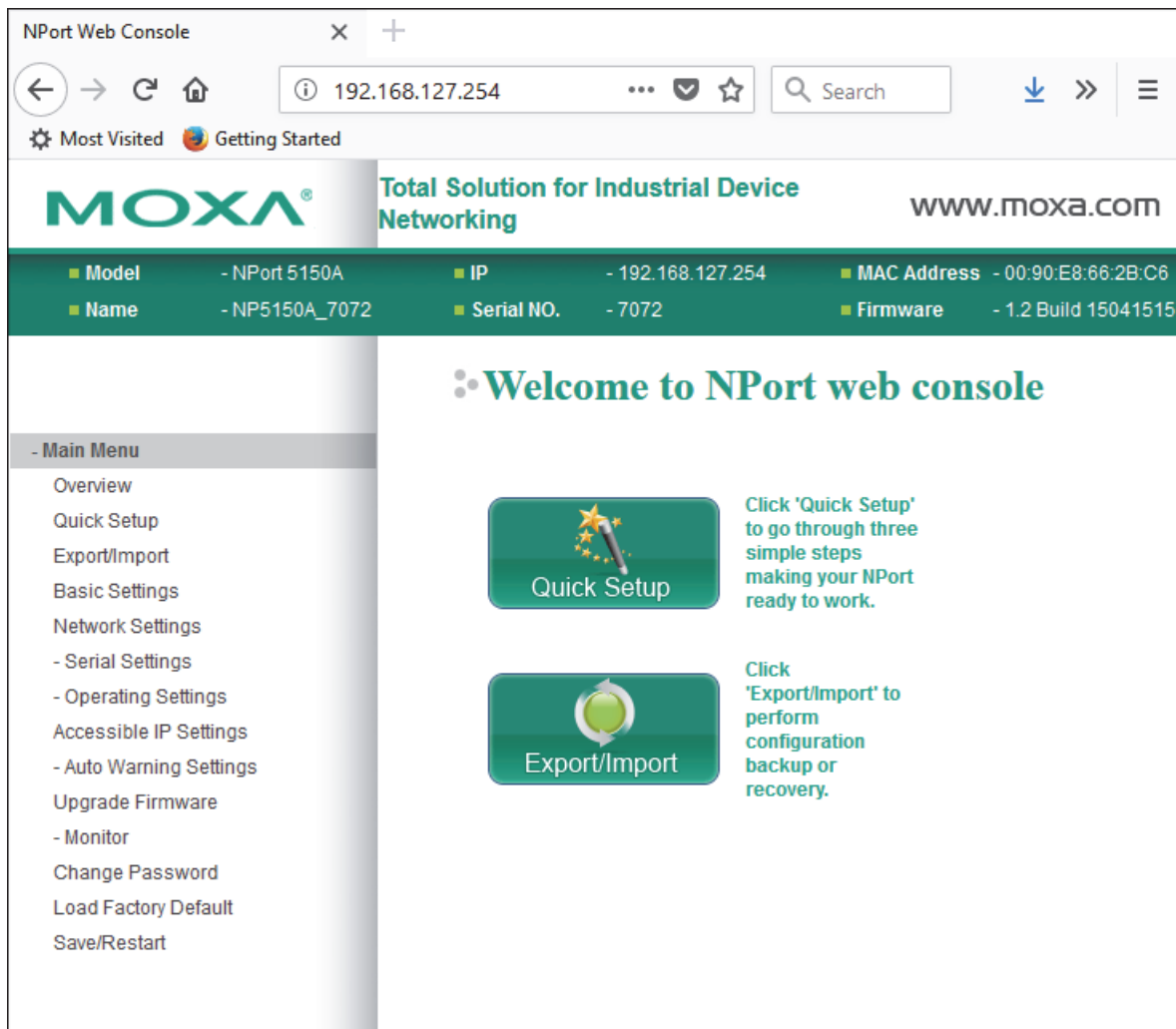

Figure 4.2 - The NPort web console Application

## Setting the IP Address

This section describes how to use the **NPort web console** to set the IP address of the VRzero module.

**Notes:**

- Each device on the network must have a unique IP address. The default IP address of the VRzero module is 192.168.127.254. We recommend you change the IP address to avoid problems if you later add another VRzero module later.
- IP addresses of the VRzero module and all destination systems must have identical first octets. The first octet consists of the digits before the first dot. For example, in the IP address 192.168.127.254, the first octet is 192.
- The **Main Menu** of the **NPort web console** application includes a **Load Factory Default** option. Do **NOT** use this option. It does not restore the VRzero module to Ross Video factory settings. If you need to restore the VRzero module to its original state, see “**Restoring the Ross Video Default Configuration**” on page 31.

**To set the IP address of the VRzero module:**

1. Access the **NPort web console** application on the VRzero module.  
For more information, see “**Accessing the Configuration Application**” on page 21.
2. On the **Main Menu**, click **Network Settings** (shown with yellow background in **Figure 4.3**).  
The **Network Settings** page appears.

**MOXA** Total Solution for Industrial Device Networking www.moxa.com

■ Model	- NPort 5150A	■ IP	- 192.168.127.254	■ MAC Address	- 00:90:E8:66:2B:C6
■ Name	- NP5150A_7072	■ Serial NO.	- 7072	■ Firmware	- 1.2 Build 15041515

## Network Settings

### Network Settings

**IP address**   
**Netmask**   
**Gateway**   
**IP configuration**   
**DNS server 1**   
**DNS server 2**

### SNMP Settings

**SNMP**  Enable  Disable  
**Community name**   
**Contact**   
**Location**

### IP Address Report

**Auto report to IP**   
**Auto report to UDP port**   
**Auto report period**  seconds

**- Main Menu**

- Overview
- Quick Setup
- Export/Import
- Basic Settings
- Network Settings
- Serial Settings
- Operating Settings
- Accessible IP Settings
- Auto Warning Settings
- Upgrade Firmware
- Monitor
- Change Password
- Load Factory Default
- Save/Restart

**Figure 4.3** - Setting the IP Address of the VRzero Module

3. In the **IP address** box, type the IP address you want to assign to the VRzero module.
4. Scroll to the bottom of the page, and then click **Submit**.  
The **Network Settings OK!** message appears.
5. Click **Save/Restart**.  
The VRzero module restarts. This takes approximately ten seconds.
6. Click **Home** to return to the **Main Menu** of the **NPort** web console.
7. On the back of the VRzero module, record the IP address you configured.

**Note:** The label on the back of the VRzero module has a blank area intended for recording the IP address (see **Figure 4.4**). Write the new IP address on the label, and obscure the old IP address (if present).



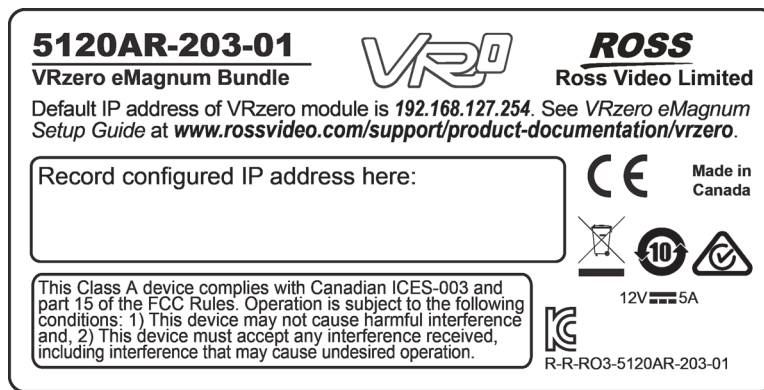

**Figure 4.4** - Label on the Back of the VRzero Module, with Space to Record the IP Address

## Specifying Data Destination Addresses

The VRzero module delivers encoder data to up to four specified destinations (IP addresses).

**Note:** The **Main Menu** of the **NPort web console** application includes a **Load Factory Default** option. Do **NOT** use this option. It does not restore the VRzero module to Ross Video factory settings. If you need to restore the VRzero module to its original state, see “**Restoring the Ross Video Default Configuration**” on page 31.

### To specify data destination addresses:

1. Access the **NPort web console** application on the VRzero module.  
For more information, see “**Accessing the Configuration Application**” on page 21.
2. On the **Main Menu**, navigate to **Operating Settings > Port 1** (shown with yellow background in **Figure 4.5**)  
The **Operation Modes** page appears.

**MOXA** Total Solution for Industrial Device Networking www.moxa.com

■ Model - NPort 5150A    ■ IP - 192.168.127.254    ■ MAC Address - 00:90:E8:66:2B:C6  
 ■ Name - NP5150A\_7072    ■ Serial NO. - 7072    ■ Firmware - 1.2 Build 15041515

### Operation Modes

**Port 1**

Operation mode:

	Begin	End	Port
Destination IP address 1	<input type="text"/>	<input type="text"/>	<input type="text" value="4001"/>
Destination IP address 2	<input type="text"/>	<input type="text"/>	<input type="text" value="4001"/>
Destination IP address 3	<input type="text"/>	<input type="text"/>	<input type="text" value="4001"/>
Destination IP address 4	<input type="text"/>	<input type="text"/>	<input type="text" value="4001"/>

Local listen port:

**Data Packing**

Packing length:  (0 - 1024)

Delimiter 1:  (Hex)  Enable

**Figure 4.5** - Specifying Destination IP Addresses

3. Set the **Operation mode** to **UDP**.
4. Specify one or more **Destination IP addresses** (numbered 1 - 4, starting at number 1):
  - a. In the **Begin** column, type the IP address.
  - b. In the **Port** box, type the number of the port through which the destination system will receive the data.
 

**Tip:** For Ross Video UX VCC, the default **Port** number is **1100**.
5. Scroll to the bottom of the page, and then click **Submit**.  
The **Operation Modes Settings OK!** message appears.
6. Click **Save/Restart**.  
The VRzero module restarts. This takes approximately ten seconds.
7. Click **Home** to return to the **Main Menu** of the **NPort web console**.

## Configuring Destination Systems

The VRzero module provides real-time position-tracking encoder data that can be used by Ross Video's Virtual Camera Controller (UX VCC) or other external systems.

This section provides information to consider when configuring your external systems to accept and use the data.

### IP Address and Port

When you configured the VRzero module, you specified up to four destinations (IP address and port). The destination systems must accept communication over the ports you specified when you configured the VRzero module. You may need to specify the port number in your VCC application.

### Data Channels

The data is transmitted using Kuper protocol over IP. There are 12 data channels, 4 of which carry encoder data. Configure your VCC system to receive data on the following channels:

- Channel 9 — Focus data
- Channel 10 — Zoom data
- Channel 11 — Tilt data
- Channel 12 — Pan data

### Setting the Encoder Scale Value for Pan and Tilt Axes

The eMagnum fluid head has 22-bit encoders on its pan and tilt axes. Your Virtual Camera Control (VCC) application must convert the raw encoder data to a format that is useful to the application.

Like many similar applications, Ross UX VCC applies a scale value to convert the raw encoder data to degrees. You must configure the application to apply the correct scale for each axis.

The required scale value is equal to 360 divided by the number of counts per revolution.

The pan and tilt encoders register 4,194,304 encoder counts per 360-degree revolution.

360 divided by 4,194,304 yields an encoder scale value of **0.0000858306884765625**.

For Ross Video UX VCC, set the pan and tilt encoder scale value to **0.00008583069**.

### Reversing Axis Orientation

By default, the orientation of the pan and/or tilt axis may be reversed compared to what your VCC application expects.

For example, the VCC application may expect the pan encoder count to decrease as the eMagnum fluid head pans clockwise, but the count actually increases instead.

You can effectively reverse the axis orientation by modifying the scale value in your VCC application. Multiply the scale by minus 1, by placing a negative symbol (-) before the scale value for that axis.

### Calibrating the Tilt Axis by Applying an Offset Value

By default, the tilt axis encoder on the eMagnum fluid head may not necessarily report a value of zero when its camera mount surface is horizontal. In VCC applications, a tilt value of zero indicates that the camera is horizontal.

To ensure that the tilt axis for your virtual camera is properly calibrated to reflect real camera tilt motion, the VCC application must be configured to compensate for the tilt encoder's non-zero value.

You can calculate and apply a tilt offset value in the VCC application to calibrate the virtual camera tilt axis with real camera tilt motion.

A high-quality level is required for accurate calibration. We recommend using a digital level.

**IMPORTANT:** Ensure that the encoder scale for the tilt axis is configured in your VCC application before you try to calibrate the tilt axis. For more information, see “**Setting the Encoder Scale Value for Pan and Tilt Axes**” on page 27.

**To calculate and apply the tilt offset value:**

1. Ensure that the body of the eMagnum is level.

**Tip:** The body of the eMagnum has a built-in bubble level.

2. Place a high-quality level on the camera mount surface (top) of the eMagnum fluid head, and then tilt the fluid head to achieve level.

**Tip:** If the top of the fluid head is perfectly level, panning it and/or repositioning the level should not affect the level reading. The top of the fluid head should remain level.

3. Lock the tilt axis and then check again to confirm that the top of the eMagnum fluid head is still level.
4. With the fluid head level, check the VCC tilt axis value. It should read as **0**.

If the VCC tilt value is not **0**, apply an offset value to the VCC’s virtual tilt axis to compensate.

# Troubleshooting

Topics in this section include:

- “**Symptoms and Possible Causes**” on page 29
- “**Finding the IP Address of a VRzero Module**” on page 30
- “**Restoring the Ross Video Default Configuration**” on page 31

## Symptoms and Possible Causes

This section describes common problems and possible solutions. If you encounter a problem that is not listed, or your require help, please contact Ross Video Technical Support (see “**Contacting Technical Support**” on page 7).

### No Tracking Data, or Intermittent Data

If your VCC application receives no tracking data, or receives data intermittently, check the following:

- Does the VRzero module have power? Check the Power LED on the module. It should be green.
- Is there network connectivity between the VRzero module and the computer running your VCC application?
  - › Is the Ethernet cable between the VRzero module and the network connected properly?
  - › Are the subnet mask and gateway configured properly? This does not apply if the system worked previously and the network settings have not changed.

### No Pan and/or Tilt Data

Check the data cables between the VRzero module and the eMagnum fluid head.

### No Lens Data (no zoom or focus data)

This topic assumes you already checked that the data cable between the lens and the VRzero module is connected.

When you use the VRzero module, you must turn on the camera and lens before applying power to the module. If the camera and lens are not powered first, the system may not be able to relay lens encoder data (zoom and focus).

To fix this problem, disconnect power from the VRzero module, wait a few seconds, and then reconnect power. After the module initializes, it should relay data.

### Virtual Elements Move in the Wrong Direction (inverted pan and/or tilt axis)

By default, the orientation of the pan and/or tilt axis may be reversed compared to what your VCC application expects.

For example, the VCC application may expect the pan encoder count to decrease as the eMagnum fluid head pans clockwise, but the count actually increases instead.

You can effectively reverse the axis orientation by modifying the scale value in your VCC application. Multiply the scale by minus 1, by placing a negative symbol (-) before the scale value for that axis.

### Jittering, Rough Motion, or Delayed Response

If your virtual elements experience jittering, rough motion, or delayed response, try the following:

- Check that the video reference (genlock/sync) data cable is properly connected and that the SYNC LED on the VRzero module is green.
- Ensure the following are synchronized:
  - › Position data from every encoded axis (pan, tilt, zoom, focus)

The VRzero module assembles encoder count data from each axis into a single data stream consisting of one data channel per axis. The data channels from the VRzero may not be synchronized to the same video frame. For example, some lenses take longer to process encoder data so their data may be delayed by a frame or two. To synchronize the data channels, adjust delay settings in your VCC application.

› Camera video

The camera video signal must be delayed by the correct number of frames to account for processing time required by the lens, the VRzero module, the VCC application, and the rendering engine.

Video delay is typically performed by a hardware device applied to the camera video output.

- If jittering and rough motion persist, check the performance of the actual scene to make sure it is running in real time.

## Finding the IP Address of a VRzero Module

This section describes how to discover the IP address of a VRzero module. This is required only if you do not know the IP address.

You can use the MOXA NPort Search Utility to detect a VRzero module on the network, and to find its IP address. The NPort Search Utility is available as a free download from the MOXA website.

**Note:** The steps in this section were accurate at the time they were written. Ross Video does not control the MOXA website, so the steps to find and download the MOXA NPort Search Utility may not work perfectly.

**To find the IP address of a VRzero module:**

1. Power **ON** the VRzero module.
2. Connect an Ethernet cable between the VRzero module and your computer.
3. Download and install the **NPort Search Utility** from the **MOXA** website:
  - a. In a web browser with Internet connectivity, navigate to <http://www.moxa.com>.
  - b. Using the **Search** tool on the MOXA website, search for **NPort 5150A**.
  - c. Follow the link to the **MOXA Device Servers** product page, and then click **Drivers & Software**.
  - d. In the **Software** list, click **Utilities**.
  - e. Download the **NPort Search Utility**, and save it locally.

A zip file with a name similar to *nploc\_setup\_Ver1.15\_Build\_14063019.zip* is downloaded. By default, it is saved in the **Downloads** folder.

- f. Unzip the file and then run the executable file (\*.exe) to launch the application's installer.
- g. During the installation process, accept all the defaults by clicking **Next** or **Finish** on each dialog.

The installation proceeds, and then the **NPort Search Utility** opens (see **Figure 5.1**).

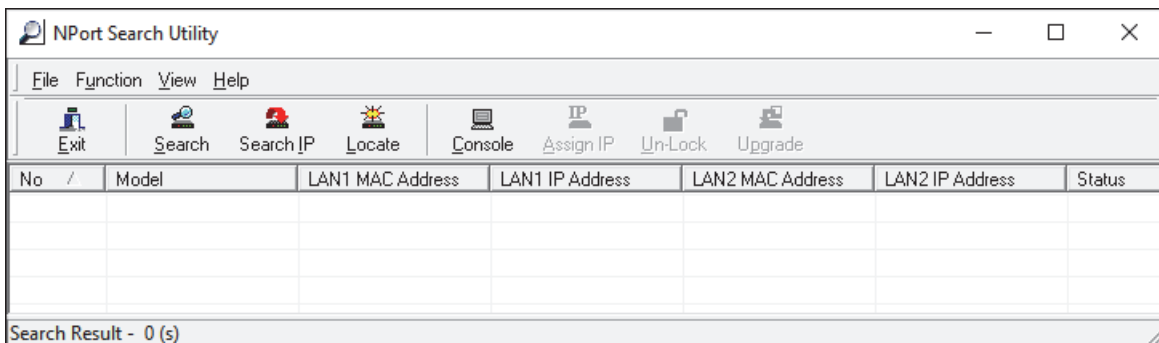

**Figure 5.1** - The NPort Search Utility

4. In the **NPort Search Utility**, click **Search**.  
The **Searching** window appears.
5. After a few seconds, an entry for the connected VRzero module appears (see **Figure 5.2**).

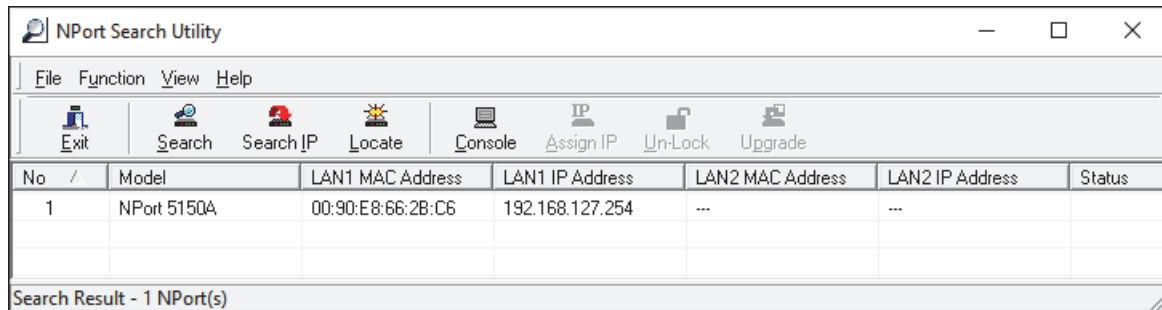

**Figure 5.2** - The NPort Search Utility Detects a VRzero Module

6. Record the IP address.

## Restoring the Ross Video Default Configuration

The VRzero module is shipped partially configured by Ross Video.

When setting up the VRzero module, you use the **MOXA NPort web console** application to configure specific properties to suit your specific application. While configuring the VRzero module, you may make a mistake and accidentally change settings, causing undesired behavior.

This section describes how to restore the VRzero module to the original Ross Video factory settings.

### To restore the VRzero module to Ross Video factory settings:

1. Access the **MOXA NPort web console** application on the VRzero module.  
For more information, see “**Accessing the Configuration Application**” on page 21.
2. If you want to later configure the VRzero module to have the current IP address and/or data destination(s), find and record the customized values:
  - a. On the **Main Menu**, click **Network Settings**.  
The **Network Settings** page appears.
  - b. Note the **IP address**.
  - c. On the **Main Menu**, navigate to **Operating settings > Port 1**.
  - d. Note each **Destination IP address** and corresponding **Port** number.
3. On the **Main Menu**, click **Load Factory Default**.  
The **Load Factory Default** page appears (see **Figure 5.3**).



**Figure 5.3** - The Load Factory Default Page

4. Scroll to the bottom of the page, and then click **Submit**.  
The **Network Settings OK!** message appears.
5. Click **Save/Restart**.  
The VRzero module restarts. This takes approximately ten seconds.
6. Click **Home** to return to the **Main Menu** of the **NPort web console**.  
**Note:** The IP address of the VRzero module is now the factory default, which is 192.168.127.254.
7. On the **Main Menu**, navigate to **Basic Settings**, and then configure the settings to match those in **Figure 5.4**.  
**Tip:** The **Basic Settings** menu item is shown with yellow background in **Figure 5.4**.

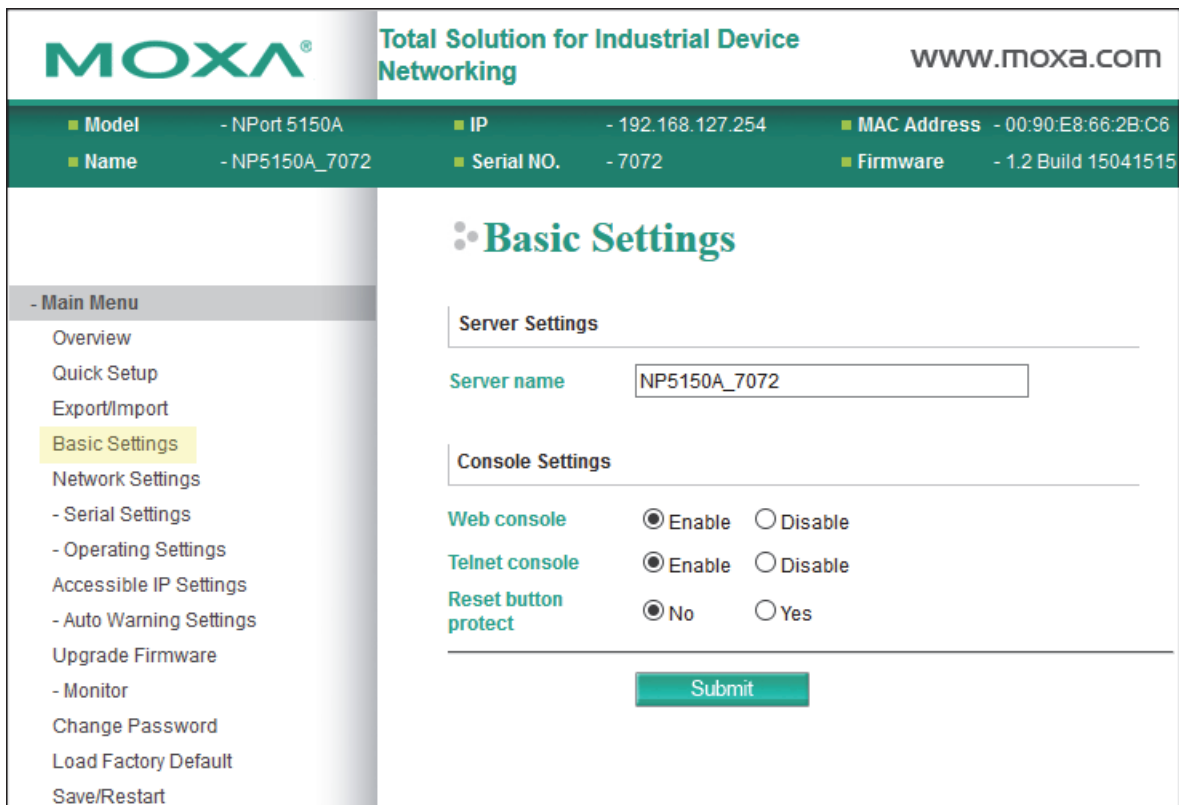

**Figure 5.4** - Ross Factory Values for the Basic Settings Page



- On the **Main Menu**, navigate to **Network Settings**, and then configure the settings to match those in **Figure 5.5**.

**Tip:** The **Network Settings** menu item is shown with yellow background in **Figure 5.5**.

**MOXA** Total Solution for Industrial Device Networking [www.moxa.com](http://www.moxa.com)

■ Model - NP5150A    ■ IP - 192.168.127.254    ■ MAC Address - 00:90:E8:66:2B:C6  
 ■ Name - NP5150A\_7072    ■ Serial NO. - 7072    ■ Firmware - 1.2 Build 15041515

**Network Settings**

**Network Settings**  
 IP address: 192.168.127.254  
 Netmask: 255.255.255.0  
 Gateway:   
 IP configuration: Static  
 DNS server 1:   
 DNS server 2:

**SNMP Settings**

SNMP:  Enable  Disable  
 Community name: public  
 Contact:   
 Location:

**IP Address Report**

Auto report to IP:   
 Auto report to UDP port: 4002  
 Auto report period: 10 seconds

**Figure 5.5** - Ross Factory Values for the Network Settings Page

- On the **Main Menu**, navigate to **Serial Settings > Port 1** and then configure the settings to match those in **Figure 5.6**.

**Tip:** The **Serial Settings > Port 1** menu item is shown with yellow background in **Figure 5.6**.

**MOXA** Total Solution for Industrial Device Networking www.moxa.com

■ Model - NP5150A    ■ IP - 192.168.127.254    ■ MAC Address - 00:90:E8:66:2B:C6  
 ■ Name - NP5150A\_7072    ■ Serial NO. - 7072    ■ Firmware - 1.2 Build 15041515

### Serial Settings

**Port 1**

Port alias

**Serial Settings**

Baud rate   
 Data bits   
 Stop bits   
 Parity   
 Flow control   
 FIFO  Enable  Disable  
 Interface

**- Main Menu**

- Overview
- Quick Setup
- Export/Import
- Basic Settings
- Network Settings
- Serial Settings**
  - Port 1**
  - Operating Settings
- Accessible IP Settings
- Auto Warning Settings
- Upgrade Firmware
- Monitor
- Change Password
- Load Factory Default
- Save/Restart

*Figure 5.6 - Ross Factory Settings for the Serial Settings > Port 1 Page*

**10.** On the **Main Menu**, navigate to **Operating Settings > Port 1** and then configure the settings to match those in **Figure 5.7**.

**Tip:** The **Operating Settings > Port 1** menu item is shown with yellow background in **Figure 5.7**.



**Total Solution for Industrial Device  
Networking**

www.moxa.com

---

■ Model - NP5150A

■ Name - NP5150A\_7072

■ IP - 192.168.127.254

■ Serial NO. - 7072

■ MAC Address - 00:90:E8:66:2B:C6

■ Firmware - 1.2 Build 15041515

---

**- Main Menu**

- Overview
- Quick Setup
- Export/Import
- Basic Settings
- Network Settings
- Serial Settings
  - Port 1
  - Operating Settings
    - Port 1
  - Accessible IP Settings
  - Auto Warning Settings
  - Upgrade Firmware
  - Monitor
  - Change Password
  - Load Factory Default
  - Save/Restart

## Operation Modes

---

**Port 1**

Operation mode:

	Begin	End	Port
Destination IP address 1	<input type="text"/>	<input type="text"/>	: 4001
Destination IP address 2	<input type="text"/>	<input type="text"/>	: 4001
Destination IP address 3	<input type="text"/>	<input type="text"/>	: 4001
Destination IP address 4	<input type="text"/>	<input type="text"/>	: 4001
Local listen port	<input type="text" value="4001"/>		

---

**Data Packing**

Packing length:  (0 - 1024)

Delimiter 1:  (Hex)  Enable

Delimiter 2:  (Hex)  Enable

Delimiter process:  (Processed only when packing length is 0)

Force transmit:  (0 - 65535 ms)

---

*Figure 5.7 - Ross Factory Settings for the Operating Settings > Port 1 Page*

11. Before you can use the VRzero module, you must configure it to suit your specific application. For more information, see “Setting the IP Address” on page 22, and “Specifying Data Destination Addresses” on page 25.



# Technical Specifications

The following table lists technical specifications for the VRzero eMagnum Bundle.

Property	Details
<b>VRzero Module</b>	
<b>Power Supply</b>	<p>Comes with power supply unit and line cord suitable for the country to which the system is shipped.</p> <p>The power supply unit accepts 100-240VAC at 50/60 Hz, and draws 1.4A current. Power supply unit output is 12VDC (5.0A, 60W maximum).</p>
<b>Tracking Data Output</b>	<p>Tracking data is transmitted using Kuper protocol over IP. There are 12 data channels, 4 of which carry encoder data.</p> <p>Configure your system to receive data on the following channels:</p> <ul style="list-style-type: none"> <li>• Channel 9 — Focus data</li> <li>• Channel 10 — Zoom data</li> <li>• Channel 11 — Tilt data</li> <li>• Channel 12 — Pan data</li> </ul>
<b>Video Reference (genlock/sync)</b>	<p>Video reference (genlock/sync) signal is input through a standard BNC connector. Tri-level and black burst formats are supported.</p> <p>The VRzero module receives video reference signal only; it does not generate the signal.</p>
<b>Inputs / Outputs</b>	<p>POWER — Power input: 12VDC, 5A</p> <p>SYNC — Video reference (genlock/sync) input</p> <p>PAN — Pan axis encoder data input from fluid head.</p> <p>TILT — Tilt axis encoder input from fluid head.</p> <p>LENS — Lens encoder data (zoom, focus) from lens.</p> <p>ETHERNET — Ethernet network connection (RJ-45). Use CAT5e cable (or better).</p>
<b>Pan and Tilt Encoding</b>	<p>22-bit encoders on pan and tilt axes yield 4,194,304 encoder counts per 360-degree revolution.</p> <p>Scale factor to convert encoder counts to degrees is 0.0000858306884765625.</p> <p>For Ross Video UX VCC, set the pan and tilt encoder scale value to 0.00008583069.</p>
<b>LED Indicators</b>	<p><b>POWER LED:</b></p> <ul style="list-style-type: none"> <li>• Solid Red — VRzero module is initializing</li> <li>• Solid Green — Module is ready.</li> <li>• Flashing Red — Networking conflict</li> <li>• Flashing Green — Occurs when module is found by NPort Search Utility's locate function.</li> </ul> <p><b>SYNC LED:</b></p> <ul style="list-style-type: none"> <li>• Solid Green — Video reference (genlock/sync) data is being received.</li> </ul>
<b>Default IP Address</b>	192.168.127.254

Property	Details
<b>Supported Lenses</b>	<p>The VRzero module has a digital lens interface with auto-detection of Canon and Fujinon lenses. No lens configuration by the user is required.</p> <p>Fully digital lenses with the following types of data ports are supported:</p> <ul style="list-style-type: none"> <li>• Fujinon 20-pin virtual port</li> <li>• Canon 20-pin virtual port</li> </ul>
<b>Compliance Statement</b>	<p>This Class A device complies with Canadian ICES-003 and part 15 of the FCC Rules. Operation is subject to the following conditions: 1) This device may not cause harmful interference and, 2) This device must accept any interference received, including interference that may cause undesired operation.</p>
<b>Encoded Fluid Head</b>	<p>Cartoni eMagnum fluid head with encoded pan and tilt axes.</p> <p>The fluid head can mount to any Mitchell flat base heavy duty tripod.</p>
<b>Cables</b>	
<b>Pan / Tilt Data Cables</b>	<p>Connect between the VRzero module and the eMagnum fluid head.</p> <p>Two identical cables, approximately 25" (64cm) long, part number <b>5120CR-305-xx</b>.</p>
<b>Lens Data Cable</b>	<p>Connects between the VRzero module and the lens.</p> <p>Two cable assemblies are included:</p> <ul style="list-style-type: none"> <li>• For Canon lenses, use Ross Video cable number <b>900-212-xx</b>.</li> <li>• For Fujinon lenses, use Ross Video cable number <b>5100CR-029-xx</b>.</li> </ul>
<b>Tripod</b> (not included, but sold separately by Ross Video)	<p>Ross video recommends and sells a Cartoni tripod for use with the eMagnum fluid head. The order code is <b>RRB-VR0-EMAG-TRI</b>.</p>