

FURIO

SkyDolly System

Technical Manual

Thank You for Choosing Ross

You've made a great choice. We expect you will be very happy with your purchase of Ross Technology. Our mission is to:

1. Provide a Superior Customer Experience
 - offer the best product quality and support
2. Make Cool Practical Technology
 - develop great products that customers love

Ross has become well known for the Ross Video Code of Ethics. It guides our interactions and empowers our employees. I hope you enjoy reading it below.

If anything at all with your Ross experience does not live up to your expectations be sure to reach out to us at solutions@rossvideo.com.



David Ross
CEO, Ross Video
dross@rossvideo.com

Ross Video Code of Ethics

Any company is the sum total of the people that make things happen. At Ross, our employees are a special group. Our employees truly care about doing a great job and delivering a high quality customer experience every day. This code of ethics hangs on the wall of all Ross Video locations to guide our behavior:

1. We will always act in our customers' best interest.
2. We will do our best to understand our customers' requirements.
3. We will not ship crap.
4. We will be great to work with.
5. We will do something extra for our customers, as an apology, when something big goes wrong and it's our fault.
6. We will keep our promises.
7. We will treat the competition with respect.
8. We will cooperate with and help other friendly companies.
9. We will go above and beyond in times of crisis. *If there's no one to authorize the required action in times of company or customer crisis - do what you know in your heart is right. (You may rent helicopters if necessary.)*

Technical Manual for Furio SkyDolly

- Ross Part Number: **5100DR-074-02**
- Release Date: February 5, 2025.

The information contained in this manual is subject to change without notice or obligation.

Copyright

©2025 Ross Video Limited. Ross® and any related marks are trademarks or registered trademarks of Ross Video Limited. All other trademarks are the property of their respective companies. PATENTS ISSUED and PENDING. All rights reserved. No part of this publication may be reproduced, stored in a retrieval system, or transmitted in any form or by any means, mechanical, photocopying, recording, or otherwise, without the prior written permission of Ross Video. While every precaution has been taken in the preparation of this document, Ross Video assumes no responsibility for errors or omissions. Neither is any liability assumed for damages resulting from the use of the information contained herein.

Patents

Ross Video products are protected by patent numbers US 7,034,886; US 7,508,455; US 7,602,446; US 7,802,802 B2; US 7,834,886; US 7,914,332; US 8,307,284; US 8,407,374 B2; US 8,499,019 B2; US 8,519,949 B2; US 8,743,292 B2; GB 2,419,119 B; GB 2,447,380 B. Other patents may apply or be pending.

Company Address and Contact Information



Ross Video Limited
8 John Street
Iroquois, Ontario
Canada, K0E 1K0

Ross Video Incorporated
P.O. Box 880
Ogdensburg, New York
USA 13669-0880

General Business Office: (+1) 613 • 652 • 4886

Fax: (+1) 613 • 652 • 4425

Toll Free Technical Support: 1-844-652-0645 (North America)
+800 1005 0100 (International)

Technical Support: (+1) 613 • 652 • 4886

E-mail for Technical Support: techsupport@rossvideo.com

ROSS VIDEO | HELP CENTER: <https://support.rossvideo.com/hc/en-us>

E-mail for General Information: solutions@rossvideo.com

Ross Video Website: <http://www.rossvideo.com>

Contents

| | |
|--|-----------|
| Welcome | 5 |
| Text Formatting Conventions | 5 |
| Contacting Technical Support | 6 |
| Safety Instructions | 7 |
| System Components | 9 |
| SkyDolly Robot Product Packages | 10 |
| Furio SkyDolly Robotic Dolly | 11 |
| SkyDolly Track Components | 15 |
| X350 Robotic Pan and Tilt Head | 22 |
| Furio VR600 Robotic Pan and Tilt Head | 24 |
| Furio S2 Two-Stage Robotic Lift | 25 |
| SmartShell Control Application | 29 |
| Accessories | 30 |
| Inspection and Maintenance | 33 |
| Robot General Inspection and Cleaning | 33 |
| Replacing the Main FRU | 34 |
| Track Inspection and Maintenance Schedule | 37 |
| Technical Specifications | 52 |
| FRO-SKY-X350-DLY Product Package | 53 |
| FRO-SKY-X350-FULL-S2 Product Package | 54 |
| FRO-SKY-VR600-DLY Product Package | 55 |
| FRO-SKY-VR600-FULL-S2 Product Package | 56 |
| SkyDolly Track, BPS, and Wiredraw Components | 57 |
| Electrical and Environmental Specifications | 58 |

Welcome

Welcome to the Technical Manual for Furio SkyDolly systems.

This manual provides a general overview of the system, technical specifications, basic maintenance procedures, and safety information.

For information about operating the system, see the ***SmartShell User Guide (5100DR-002-xx)***.

IMPORTANT: This manual provides general product information and describes how to perform selected maintenance tasks. It is not a comprehensive service manual and is not a replacement for product commissioning or formal training.

IMPORTANT: Initial setup and commissioning must be performed by Ross Video personnel only. Unauthorized attempts by customers or third parties to unpack, assemble, or commission any portion of the robotics system may result in equipment damage and/or serious injury. Any such attempts may void product warranties.

Text Formatting Conventions

Special text formats are used in this Technical Manual to identify parts of the user interface, text that a user must enter, or a sequence of menus and sub-menus that must be followed to reach a particular command.

| Text Format | Meaning |
|---------------------------|--|
| Bold text | Bold text is used to identify a user interface element such as a dialog box, menu item, or button. For example: In the Presets panel, tap ADD . |
| <code>Courier text</code> | Courier text is used to identify text that a user must type. For example: In the address bar, type <code>localhost</code> and press Enter . |
| <i>Italic text</i> | Italic text is used to identify the titles of referenced guides, manuals, or documents. For example: For more information, refer to the <i>SmartShell User Guide (5100DR-002-xx)</i> . |
| > | Menu arrows are used in procedures to identify a sequence of menu items that you must follow. For example, if a step reads " Display > Widgets ," you would tap the Display menu and then tap Widgets . |

Contacting Technical Support

At Ross Video, we take pride in the quality of our products, but if problems occur, help is as close as the nearest telephone.

Our 24-hour Hot Line service ensures you have access to technical expertise around the clock. After-sales service and technical support is provided directly by Ross Video personnel.

During business hours (Eastern time), technical support personnel are available by telephone any time. Emergency after hours calls are answered by an answering service (live person) who will patch your call to the on-call support specialist. In the event that the on-call person is assisting another customer, the answering service will contact the back-up support specialist.

Our team of highly trained staff is available to react to any problem and to do whatever is necessary to ensure customer satisfaction.









- **Toll Free Technical Support 24/7:** 1-844-652-0645 (North America), or +800 1005 0100 (International)
- **Technical Support:** (+1) 613-652-4886
- **E-mail for Technical Support:** techsupport@rossvideo.com
- **ROSS VIDEO | HELP CENTER:** <https://support.rossvideo.com/hc/en-us>
- **E-mail for General Information:** solutions@rossvideo.com
- **Ross Video Website:** <http://www.rossvideo.com>











Safety Instructions

[Table 1](#) contains important safety instructions and notices. Before using this product and any associated equipment, read and keep these instructions and notices. Heed all warnings and follow all safety instructions

Important: Before operating or servicing any Furio system, please refer to and carefully read the *Furio Safety Guide (5100DR-304-02)* to ensure safe handling and operation.

Table 1 - Safety Instructions and Notices

| | |
|--|--|
|  Caution | <p>This equipment must be operated by trained personnel only. This equipment must be operated in a controlled and restricted-access environment only.</p> |
|  Warning | <p>The safe operation of this product requires that a protective earth connection be provided. A grounding conductor in the equipment's supply cord provides this protective earth. To reduce the risk of electrical shock to the operator and service personnel, this ground conductor must be connected to an earthed ground. Use only power cords specified for this product and certified for the country of use. Do not defeat safety purpose of the grounding-type plug. A grounding type plug has two blades and a third grounding prong. The third prong is provided for your safety. If the provided plug does not fit in to your outlet, consult an electrician for replacement of the obsolete outlet. Protect power cord from being walked on or pinched, particularly at plugs, convenience receptacles, and points where they exit from the apparatus.</p> |
|  ESD | <p>ESD Susceptibility — This symbol on the equipment or within the equipment manual indicates that an electrical or electronic device or assembly is susceptible to damage from an ESD event.</p> |
|  Warning | <p>Hazardous Voltages — This symbol on the equipment or within the equipment manual indicates the presence of uninsulated “dangerous voltage” within the product enclosure that may be of sufficient magnitude to constitute a risk of shock to persons.</p> |
|  Warning | <p>WARNING – TO REDUCE THE RISK OF FIRE OR ELECTRIC SHOCK, DO NOT EXPOSE THIS APPARATUS TO RAIN OR MOISTURE Do not use this apparatus near water. Do not block any ventilation openings. Install in accordance with manufacturer's instructions. Do not install near heat sources such as radiators, heat registers, stoves, or other apparatus (including amplifiers) that produce heat. Only use attachments/accessories specified by the manufacturer. Unplug this apparatus during lightning storms to avoid damaging power surges. Clean only with a dry cloth.</p> |
|  Warning | <p>Refer all servicing to qualified personnel. Servicing is required when the apparatus has been damaged in any way, such as power-supply cord or plug damage, liquid has been spilled or objects have fallen into the apparatus, the apparatus has been exposed to rain or moisture, does not operate normally, or has been dropped.</p> |
|  Warning | <p>To reduce the risk of fire, replacement fuses must be the same type and rating.</p> |
|  Warning | <p>This product contains safety critical parts, which if incorrectly replaced may present a risk of fire or electrical shock. Components contained within the product's power supplies and power supply area are not customer-serviceable and should be returned to the factory for repair.</p> |

| | | |
|---|----------------|---|
|  | Caution | Ensure that proper cable management techniques are used at all times. Bundle and wrap cables neatly, and provide adequate strain relief and slack where necessary. Test your cable installation by slowly moving the robotic units through their entire range of motion and observing the cables, to ensure that they do not become taut, or snag on anything. Inspect cables periodically for damage, and to ensure that proper cable management is maintained. |
|  | Warning | Damaged or improper cables may cause electric shock and/or fire. Ensure that all cables and connectors are of suitable type for their purpose, and that all power cable conductors are of adequate gauge for the voltage and current required. Inspect all cables periodically to check for damage. If a cable becomes damaged, turn off power to the system immediately, and then replace the damaged cable. |
|  | Warning | Serious injury can result from collisions between people and robots. If a robot or payload hangs low enough that it can collide with people in the studio, special precautions should be taken to prevent such collisions. Methods of reducing the risk of such collisions and injuries include, but are not limited to, the following: <ul style="list-style-type: none"> • Erecting signs at studio entrances to remind people about the presence of moving robots and other studio hazards. • Training personnel about safety procedures. • Showing personnel and guests the location of equipment, and explaining that robotic camera systems and cables attached to them may move at any time. • Escorting guests at all times while in the studio. • Erecting safety barriers to keep personnel away from the path of the robot(s). • Ensuring adequate lighting when working in the studio. • Marking safe paths and/or restricted areas, to keep people away from moving robots. • Ensuring that the Operator has a good view of the entire track and that they visually monitor the movement of robots and people to ensure they do not collide. |
|  | Caution | Loose or overtightened bolts may cause equipment damage. When servicing, tighten bolts to specified torque. |
|  | Warning | Moving parts may present a pinching hazard. Keep all personnel away from robots when they are operational. When a robotic head, dolly, or lift moves, fingers touching or near the unit, payload, or cable trolleys may become pinched. When installing or adjusting the payload, ensure that power to the system is turned off. |
|  | Warning | When servicing or moving equipment, always observe safe handling practices. Get help to move heavy items. Use safe lifting techniques. If working at heights, use proper equipment and techniques. Follow all safety rules of your workplace. |
|  | Caution | Loose payloads may slip, causing equipment damage and injury. Periodically check all bolts that fasten the payload, to ensure that they are tightened to specified torque. If the payload is loose or slips, ensure that it is properly balanced and fastened before operating the robot. |
|  | Caution | Imbalanced payloads may cause equipment damage. Ensure payloads are properly balanced. If you adjust a payload, always rebalance it. |
|  | Caution | Failure to inspect and maintain equipment may result in equipment damage and loose parts falling. Ensure that qualified personnel conduct all scheduled inspection and maintenance tasks described in this manual. If the system malfunctions, discontinue use until it has been repaired and deemed safe. |
|  | Warning | Do not move, modify, or remove any safety features, including track reflectors, safety bumpers, safety warning labels, and emergency stop (E-STOP) buttons. |
|  | Warning | Ensure that the Operator has a good view of the entire track at all times. Ensure there is an emergency stop box (E-STOP button) for each dolly within easy reach of the Operator, and that they know how to use it. |

System Components

The Furio SkyDolly system features one or two robotic dollies riding on a suspended track mounted to a dedicated truss assembly.

Components of the SkyDolly robotic camera dolly ([Figure 1](#)) are designed to be modular.

Each dolly includes:

- One of two truss types (ladder or box)
- A dolly head (X350, VR600)
- A BPS unit (and previously wiredraw unit)
- Either a fixed-height column (various lengths available) or a two-stage Furio S2 robotic lift

Note: The VR100 pan tilt has been End of Production since June 16th 2023. Product support is available for 7 years following the EOP date. Hardware maintenance is available to purchase but cannot exceed the EOP date. To learn more about upgrading your Furio Robot Package, contact your regional sales manager.

The dolly's electronic controls are contained within a field-replaceable unit (Main FRU). Each dolly features four auxiliary power outlets (IEC C13 female) for powering the camera and accessories.

Two-robot systems may also include a Furio Collision Avoidance module, which helps prevent robotic dollies from colliding with each other (see "**Furio Collision Avoidance System**" on [page 30](#)).

The Furio SkyDolly robots are operated from a SmartShell control station, which can also control all other Ross Video robotic camera systems.

Figure 1 - Furio SkyDolly with Fixed-Height Column (left), and with S2 Lift (right)

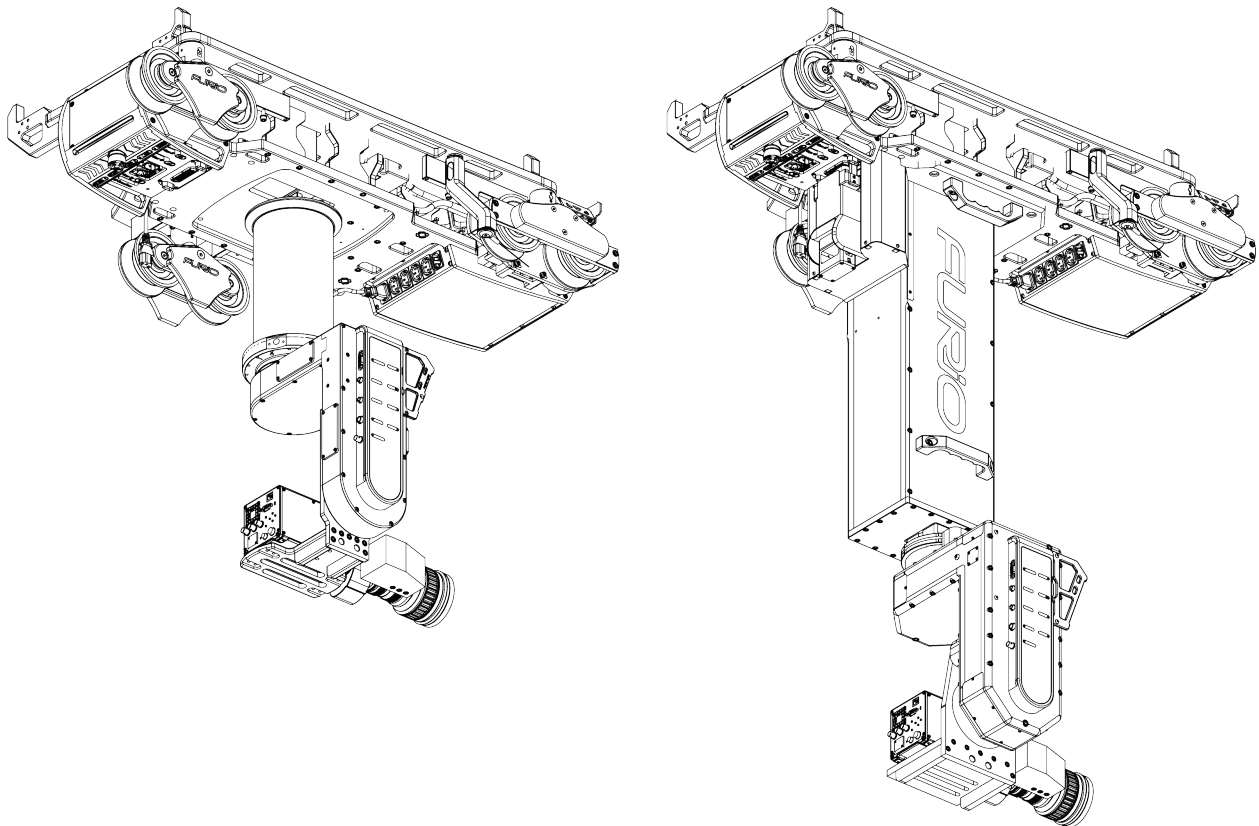

This section provides information about components of the Furio Sky Dolly system, and includes the following topics:

- “**SkyDolly Robot Product Packages**” on [page 10](#)
- “**Furio SkyDolly Robotic Dolly**” on [page 11](#)
- “**SkyDolly Track Components**” on [page 15](#)
- “**X350 Robotic Pan and Tilt Head**” on [page 22](#)
- “**Furio VR600 Robotic Pan and Tilt Head**” on [page 24](#)
- “**Furio S2 Two-Stage Robotic Lift**” on [page 25](#)
- “**SmartShell Control Application**” on [page 29](#)
- “**Accessories**” on [page 30](#)

SkyDolly Robot Product Packages

This section lists the available SkyDolly robot packages, and the main components included in each.

Each SkyDolly robot package includes one or more robotic components (dolly, lift, head) and may also include a fixed-height column. All other system components and accessories are sold separately. Truss and track layouts are custom-designed for each installation.

Full robot packages include a SkyDolly, a robotic pan/tilt head, and either a robotic lift or a fixed-height column (various lengths are available; see “**Fixed-Height Columns**” on [page 31](#)).

Upgrade packages include one or more supplemental robotic components that enable customers to enhance an existing robot. Once upgraded, the robot consists of the same components as one of the full robot packages.

SkyDolly robot packages are as follows:

- **FRO-SKY-X350-DLY** — Full robot package consisting of an X350 pan/tilt head attached to a Furio SkyDolly via a fixed-height column.
- **FRO-SKY-X350-FULL-S2** — Full robot package consisting of an X350 pan/tilt head attached to a Furio SkyDolly via a Furio S2 two-stage robotic lift.
- **FRO-SKY-VR600-DLY** — Full robot package consisting of a Furio VR600 pan/tilt head attached to a Furio SkyDolly via a fixed-height column.
- **FRO-SKY-VR600-FULL-S2** — Full robot package consisting of a Furio VR600 pan/tilt head attached to a Furio SkyDolly via a Furio S2 two-stage robotic lift.
- **FRO-SKY-DLY-UPG** — Upgrade package consisting of a Furio SkyDolly plus fixed-height column, without a robotic head. This package is suitable for customers who already own a Furio VR100 or VR600 robotic head and want to upgrade to a full suspended-track SkyDolly system.
- **FRO-SKY-FULL-S2-UPG** — Upgrade package consisting of a Furio SkyDolly plus Furio S2 two-stage lift, without a robotic head. This package is suitable for customers who already own a Furio VR100 or VR600 robotic head and want to upgrade to a full suspended-track SkyDolly system.
- **FRO-SKY-S2-UPG** — Upgrade package consisting of a Furio S2 two-stage lift only. This package is suitable for customers who already own a Furio SkyDolly system and want to add a robotic lift to a dolly.

For more information about each product package, see “**Technical Specifications**” on [page 52](#).

Furio SkyDolly Robotic Dolly

The heart of the Furio SkyDolly system is the track-based dolly, also referred to as a SkyDolly.

SkyDolly features include the following:

- Dual-switched DC power supplies that automatically accept voltages between 90 VAC and 250 VAC (at 50/60Hz), offering global compatibility without reconfiguration.
- An internal DC power converter for the pan & tilt head, which eliminates the need for an external power brick.
- Integrated power bar that provides mains power for cameras, prompters, clocks, and more. All electrical connections feature self-recovering over-current detection to protect electrical circuits, and a complete array of status LEDs accelerate fault detection and diagnosis.
- Three wheel sets, each made up of two split-wheels to eliminate vibration around curves. The wheels are made of pliable silicone to minimize rolling noise.
- Connection for a remote emergency stop module, which enables the Operator to quickly halt the dolly.
- When the **EMERGENCY STOP** button is pushed, the lift stays in its current position, the head becomes free-wheeling, and the dolly comes to a rapid controlled stop thanks to its constant current regenerative braking technology.

For more information, see “**Remote Emergency Stop Module**” on [page 15](#).

- Safety guide posts that work in conjunction with the track’s safety rails, making it impossible for the SkyDolly to fall.
- On-board optical sensor arrays that detect warning reflectors to prevent the dolly from reaching the end of the track, in case track limits are not properly set in the control application.
- A manual lift control switch that enables you to raise or lower the lift locally without a network connection or control system. The manual lift control switch can lower the lift to its absolute bottom position. This may help provide a better working height for servicing the robotic head, or make the overall size of the lift smaller to facilitate shipping.

Figure 2 - Furio SkyDolly (shown without lift or head)

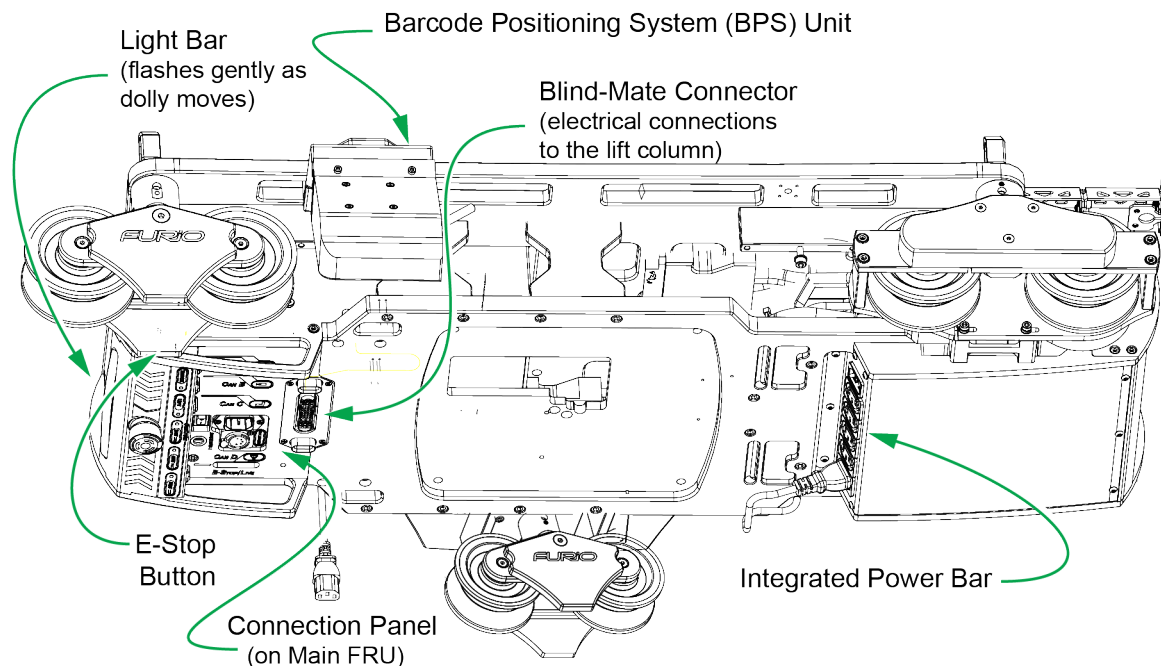

To turn the SkyDolly ON or OFF, do one of the following:

- Flip the power switch on the Main FRU (**Figure 3** on [page 12](#)).

The power switch controls power to the Main FRU, which powers the dolly, robotic lift (if present), and the robotic head. The power switch does not control the power bar on the other end of the dolly. Because the power switch is located on the dolly, it may be difficult to access. Customers typically leave dollies powered **ON** for long periods of time.

IMPORTANT: Always turn the dolly power switch **OFF** before connecting or disconnecting any cables.

- Connect or disconnect power from the AC mains.

Tip: When you reconnect to the AC mains, the dolly takes approximately one minute to initialize before it can be operated.

Tip: We recommend using a dedicated power supply circuit for each dolly.

IMPORTANT: Always disconnect power from the AC mains before servicing the dolly or any other powered SkyDolly components.

Main FRU (Field Replaceable Unit)

The **Main FRU** contains all the control electronics. All network and power connections for the dolly, lift, and head are through blind-mate connectors on the top or end of the Main FRU, or through cable connections on the Main FRU's connection panel (Figure 3 and Figure 4).

The Main FRU can be quickly replaced with the removal of just four screws. For more information, see "Replacing the Main FRU" on page 34.

Figure 3 - SkyDolly Main FRU Connection Panel

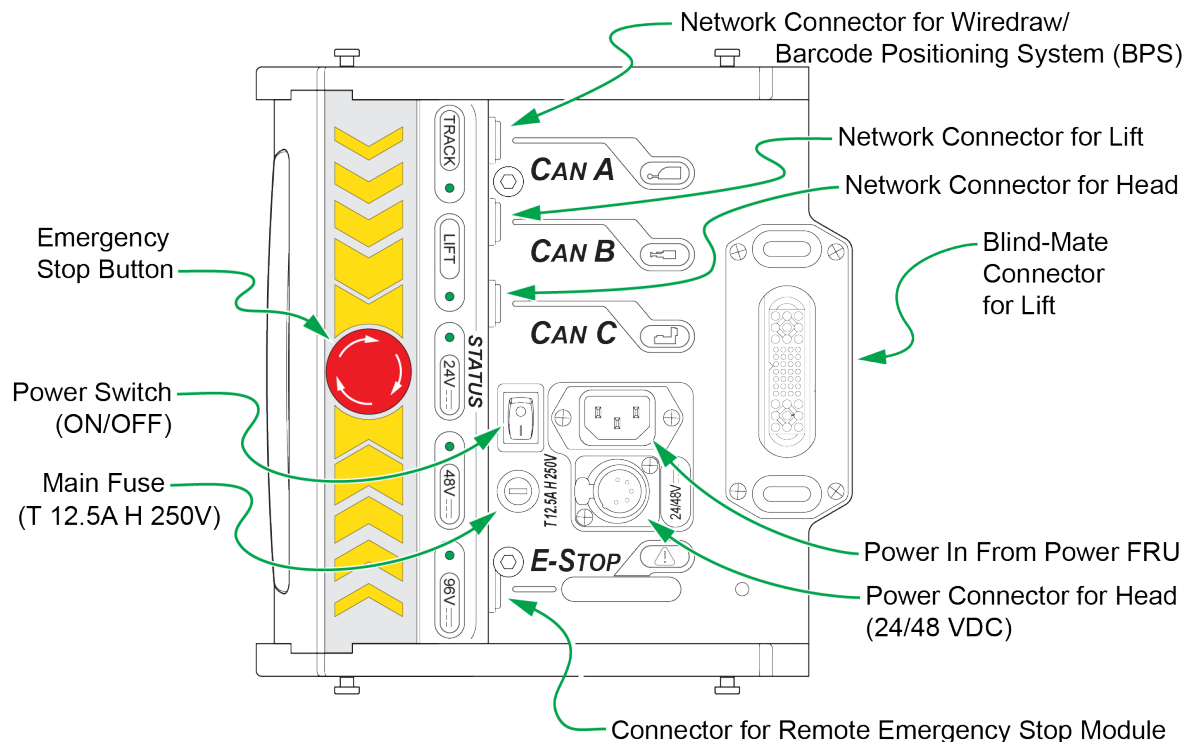

Figure 4 - CAN connectors and LEDs on the Main FRU Connection Panel

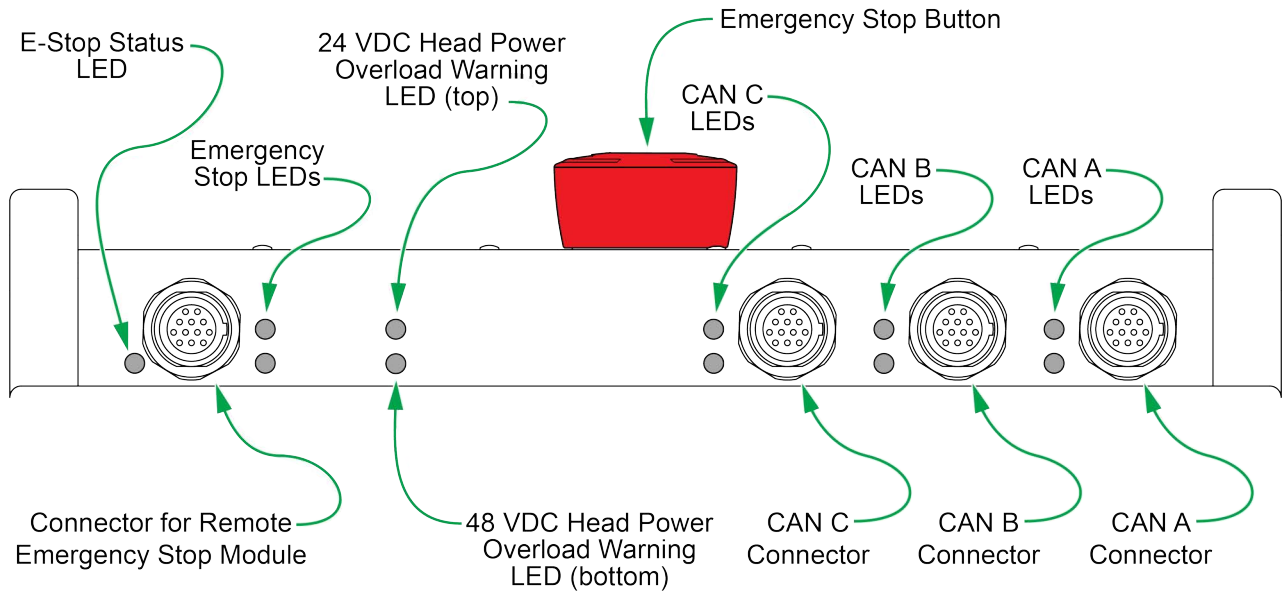

Table 2 lists and describes LEDs on the Main FRU connection panel (as shown in Figure 3 and Figure 4).

Table 2 - Descriptions of LEDs on the Main FRU Connection Panel

| LED | Description / Meaning |
|---|---|
| TRACK | Track axis status: <ul style="list-style-type: none"> • green: operational • red: disabled or faulty See also Note 1 , after this table. |
| LIFT | Lift axis status: <ul style="list-style-type: none"> • green: operational • red: disabled or faulty See also Note 1 , after this table. |
| 24 V | 24 VDC power supply status: <ul style="list-style-type: none"> • green: good • off: undervoltage or no power |
| 48 V | 48 VDC power supply status: <ul style="list-style-type: none"> • green: good • off: undervoltage or no power |
| 96 V | 96 VDC power supply status: <ul style="list-style-type: none"> • green: good • off: undervoltage or no power |
| CAN A — 24 VDC overload warning (top LED beside CAN A connector) | 24 VDC overload warning for wiredraw encoder CAN connection: <ul style="list-style-type: none"> • off: no overload • red: overload or short-circuit |
| CAN A — 48 VDC overload warning (bottom LED beside CAN A connector) | Not used. Reserved for future use. |

| LED | Description / Meaning |
|---|---|
| CAN B — 24 VDC overload warning (top LED beside CAN B connector) | 24 VDC overload warning for lift encoder CAN connection: <ul style="list-style-type: none"> • off: no overload • red: overload or short-circuit |
| CAN B — 48 VDC overload warning (bottom LED beside CAN B connector) | Not used. Reserved for future use. |
| CAN C — 24 VDC overload warning (top LED beside CAN C connector) | 24 VDC overload warning for robotic head: CAN connection: <ul style="list-style-type: none"> • off: no overload • red: overload or short-circuit |
| CAN C — 48 VDC overload warning (bottom LED beside CAN C connector) | Not used in Furio SkyDolly studio systems. Reserved for use in Furio SE remote (SE Live) systems. |
| 24 VDC head power overload warning (top LED adjacent to the main fuse) | Overload warning for VR100 head: <ul style="list-style-type: none"> • off: no overload • red: overload or short-circuit See also Note 2 , after this table. |
| 48 VDC head power overload warning (bottom LED adjacent to the main fuse) | Overload warning for VR600/X350 head: <ul style="list-style-type: none"> • off: no overload • red: overload or short-circuit See also Note 2 , after this table. |
| E-STOP — 24 VDC overload warning (top LED right of E-STOP CAN connector) | 24 VDC overload warning for E-STOP box/dongle CAN connection: <ul style="list-style-type: none"> • off: no overload • red: overload or short-circuit |
| E-STOP — 48 VDC overload warning (bottom LED right of E-STOP CAN connector) | Not used. Reserved for future use. |
| Emergency Stop status warning (left of the Emergency Stop CAN connector) | Operations status for E-STOP safety: <ul style="list-style-type: none"> • off: operational • red: E-STOP activated, and must be reset before operation can resume. Note: If there is no E-STOP box, an E-STOP dongle must be inserted for normal operation. |

Additional NOTES about LEDs described in [Table 2](#):

- The **TRACK** axis and **LIFT** axis status LEDs turn red under any of the following conditions:
 - Amplifier fault
 - Amplifier over temperature
 - Motor phasing error
 - Motor over temperature
 - Under voltage
 - Over voltage
 - Short circuit
 - Phase not initialized
 - Command input fault
- The power connector for the head (24 VDC / 48 VDC) is protected against overcurrent by resettable fuses. Each of the associated LEDs (adjacent to the main fuse) turns red when its fuse trips (top LED for 24 VDC VR100 supply, bottom LED for 48 VDC VR600/X300 supply).

When the faulty cable or device is unplugged, the associated LED turns off but the fuse may take up to one minute to cool completely and reset.

Remote Emergency Stop Module

The remote emergency stop module ([Figure 5](#)) enables an operator to remotely stop the robot to which the module is connected.

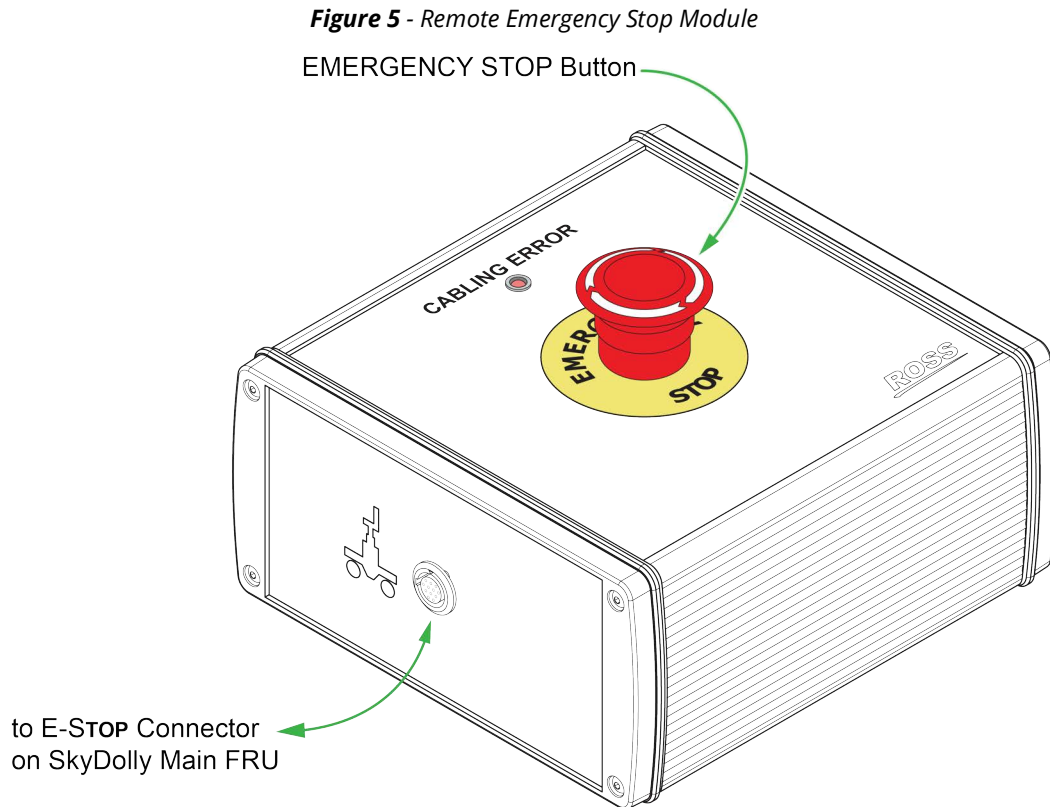

When the red **EMERGENCY STOP** button is pushed, the lift stays in its current position, the head becomes free-wheeling, and the dolly comes to a rapid controlled stop thanks to its constant current regenerative braking technology.

To disengage the emergency stop, gently twist the red **EMERGENCY STOP (E-Stop)** button clockwise. The button pops up. When an E-Stop is triggered, SmartShell requires a software reset to resume normal operation after the physical E-Stop is resolved.

On the dolly, the remote emergency stop module connects to the Main FRU's connection panel (see [Figure 3](#) on [page 12](#)).

SkyDolly Track Components

The Furio SkyDolly system features one or two robotic dollies riding on a suspended track mounted to a dedicated truss assembly. The position of each dolly along the track is monitored via a Barcode Positioning System (BPS).

This section describes components of the SkyDolly track, and includes the following topics:

- “**SkyDolly Truss and Track**” on [page 16](#)
- “**Barcode Positioning System (BPS)**” on [page 18](#)

- “Safety Bumpers” on [page 19](#)
- “Track Limit Reflector Brackets” on [page 20](#)
- “Cable Trolleys” on [page 21](#)

SkyDolly Truss and Track

SkyDolly truss and track layouts are custom-designed for each installation.

Rail support frames are mounted to the SkyDolly truss to support dolly rails and safety rails (see [Figure 6](#), [Figure 7](#), and [Figure 8](#)).

Note: There are two kinds of trusses attached to the rails, a setup can either have a box truss ([Figure 7](#)) or a ladder truss ([Figure 8](#)).

The dolly rides on the dolly rails. The safety rails prevent the dolly from derailing and make it impossible for the dolly to fall. They also support rolling cable trolleys, which carry all cables that run to the dolly.

Figure 6 - SkyDolly Box Truss and Track (angled view)

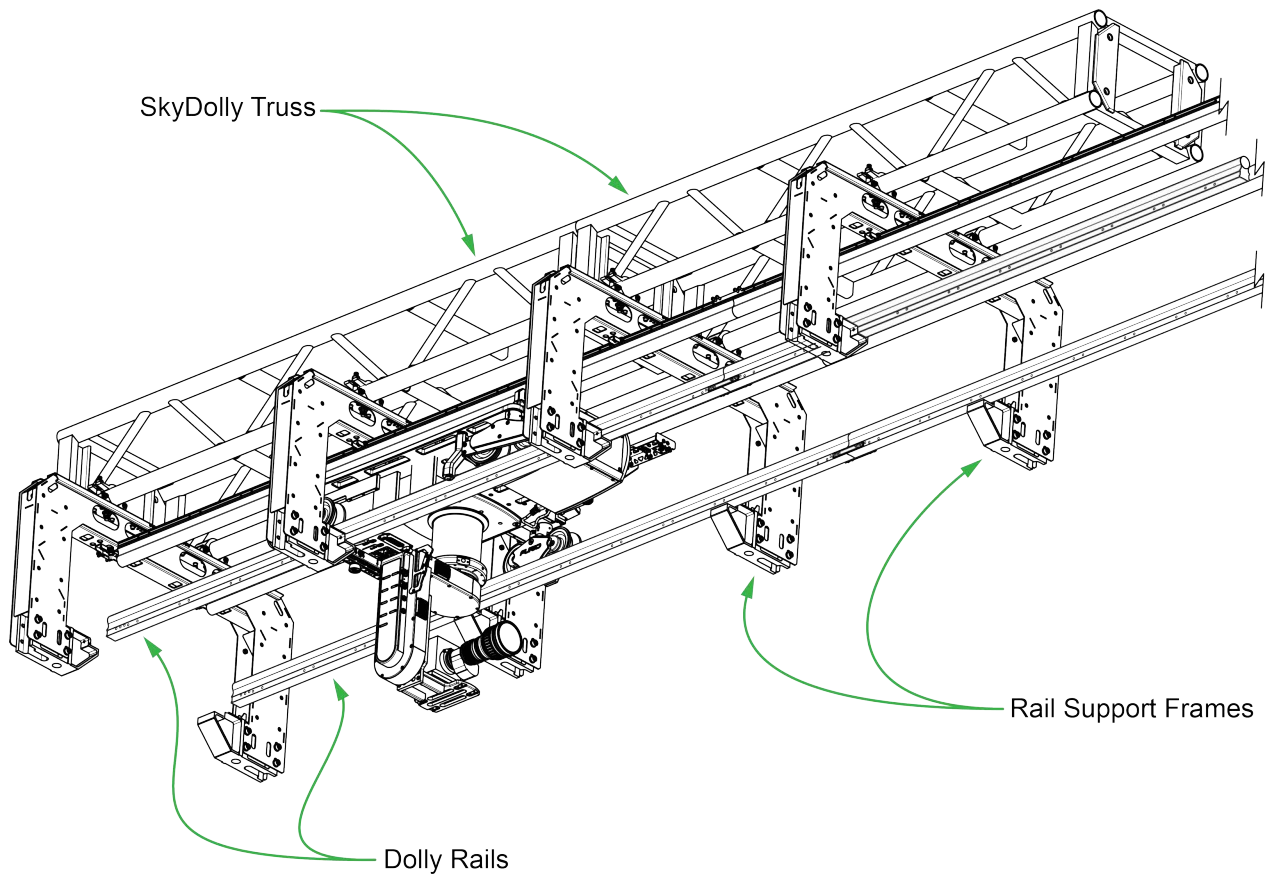

Figure 7 - Furio SkyDolly Suspended Track (end view) - Box Truss

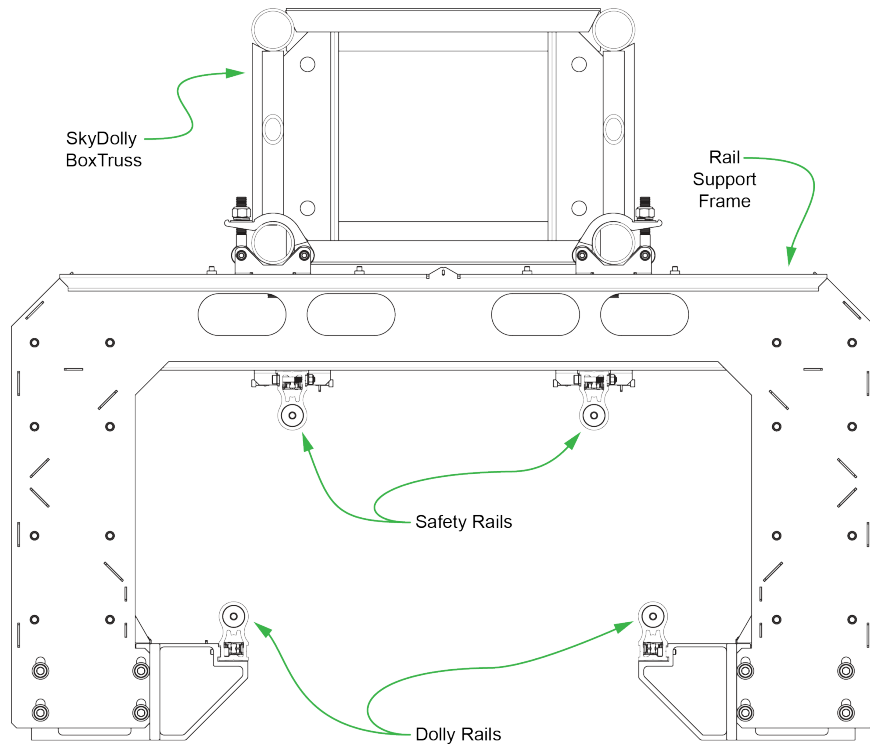
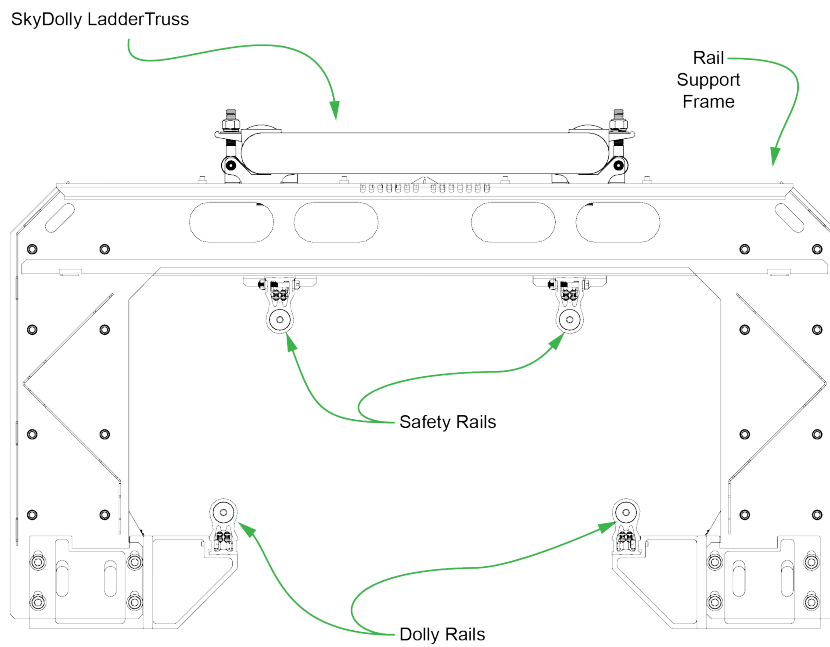

Figure 8 - Furio SkyDolly Suspended Track (end view) - Ladder Truss



Barcode Positioning System (BPS)

The Barcode Positioning System (BPS) replaces traditional wiredraw encoders in all SkyDolly models effective July 2024. This transition enhances the precision, reliability, and maintenance of the system.

Operating BPS on a Furio SkyDolly System requires **SmartShell v7.0b** or higher with template files properly configured.

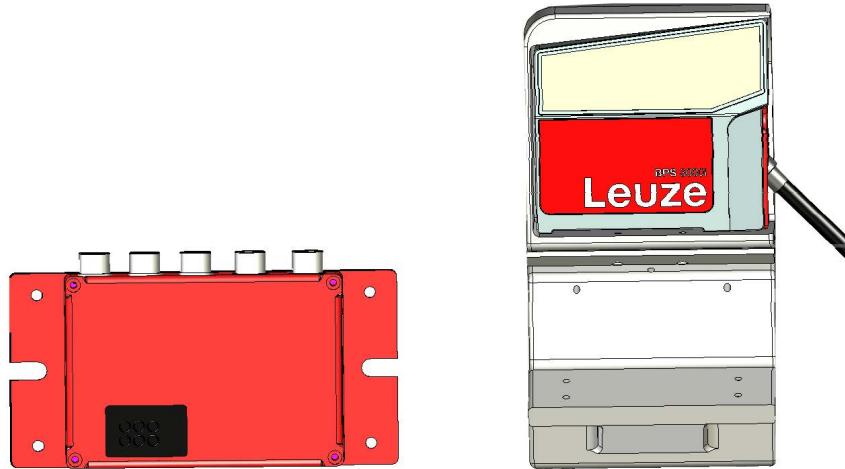

Figure 9 Gateway, BPS Unit, BPS Bracket, and CAN Cable (not all kit components shown)

For BPS upgrade installation instructions, refer to the **SkyDolly BPS Upgrade Guide (5100DR-383-01)**.

Note: Depending on the setup, BPS Upgrade Kits are available to support either inner or outer rail scanning. Ensure you use the correct one for the SkyDolly setup. Refer to [Figure 10](#).

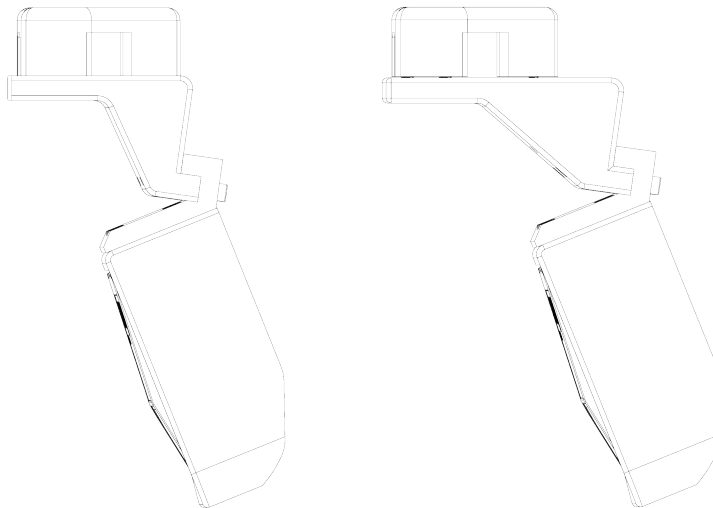

Figure 10 - BPS for Inner Rail Scanning (Left) vs. Outer Rail Scanning (Right)

Key Specifications

- **Accuracy:** Submillimeter positioning accuracy from 0 to 10,000 meters.
- **Speed:** Control at traverse rates up to 5 millimeters per second.
- **Measurement:** Simultaneous position and speed measurement.

Environmental Requirements

- **Operating Temperature:** -35°C to 50°C (with heating).
- **Humidity:** 0% to 90% relative humidity, non-condensing.
- **Lighting:** Avoid direct exposure to intense, direct lighting; ensure consistent lighting conditions.
- **Cleanliness:** Maintain a clean environment; regular cleaning of barcode tape and sensors with a soft cloth and commercial glass cleaner.

Installation and Mounting

When mounting the BPS unit and installing barcode tape:

- Ensure barcode tape is free of wrinkles and mechanical tension.
- Barcode tapes are available in the following lengths:
 - › 10 meters (Product Code FRO-BPS-TAPE-10)
 - › 20 meters (Product Code FRO-BPS-TAPE-20)
 - › 30 meters (Product Code FRO-BPS-TAPE-30)
 - › 40 meters (Product Code FRO-BPS-TAPE-40)
 - › 50 meters (Product Code FRO-BPS-TAPE-50)
 - › 70 meters (Product Code FRO-BPS-TAPE-70)

Maintenance

Routine checks include:

- Regularly inspect barcode tape for wear or damage.
- Clean optical sensors and barcode tape to ensure accurate readings.
- Perform firmware updates as needed via Ross Video customer service.

Safety Bumpers

Spring-loaded safety bumpers physically stop a dolly if it reaches the end of the track.

The bumpers are a backup safety measure designed to prevent serious damage to equipment. Track limits and dolly speed limits must be configured on the robotic head to prevent the dolly from ever reaching the safety bumpers. Track limit reflectors must be installed as an additional safety measure.

When a safety bumper unit is installed at the same end of the track as a wiredraw unit, space between the units acts as a stackup zone for cable trolleys ([Figure 11](#)).

Figure 11 - Side View of Track Components, featuring Reflector Bracket, Bumper Unit, and Wiredraw Unit

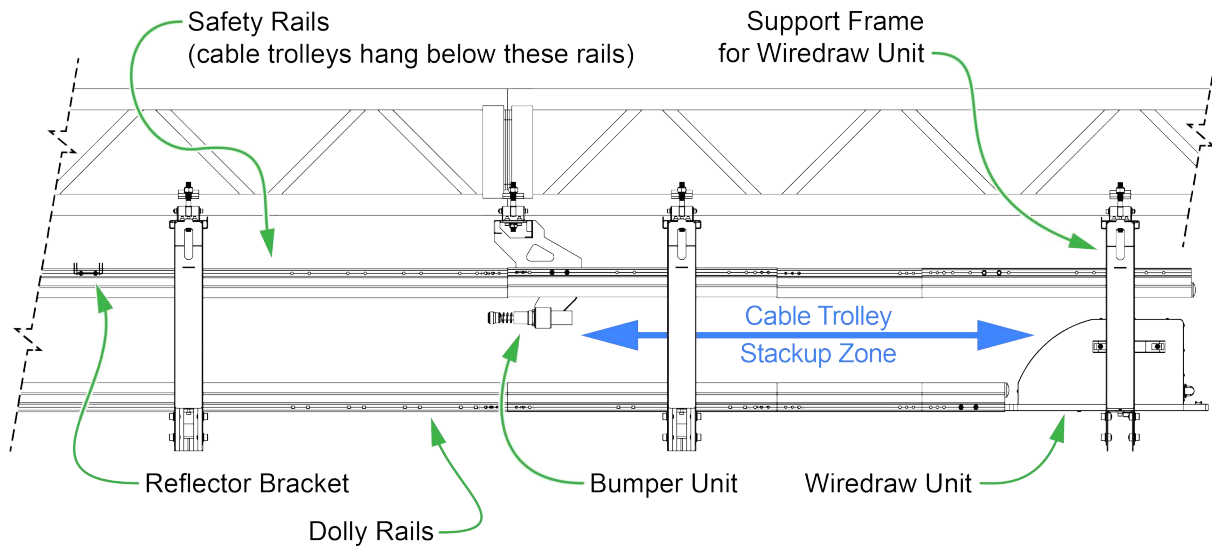

IMPORTANT: If a dolly collides forcefully with a bumper, equipment damage may occur. Immediately inspect the dolly, lift or column, head, and payload carefully to ensure that all components are intact and undamaged.

Track Limit Reflector Brackets

Track limit reflectors act as a backup safety measure to help prevent dollies from hitting the safety bumpers at the ends of the track.

Each end of the dolly has an on-board optical sensor array to detect reflectors and prevent the dolly from reaching the end of the track, in case track limits and/or dolly speed limits are not properly configured on the robotic head.

One reflector bracket ([Figure 12](#)) is installed near each end of the track, with allowance for ample stopping distance between the reflector bracket and the safety bumper. The reflector is fastened to the bracket in one of four positions so it aligns with the optical sensor array on the nearest end of the closest dolly.

Each safety bumper kit comes with one reflector bracket and a reflector. The reflector bracket and reflector can also be ordered (FRO-SKY-RFLT-BRK).

Figure 12 - SkyDolly Track Limit Reflector Bracket (FRO-SKY-RFLT-BRK)

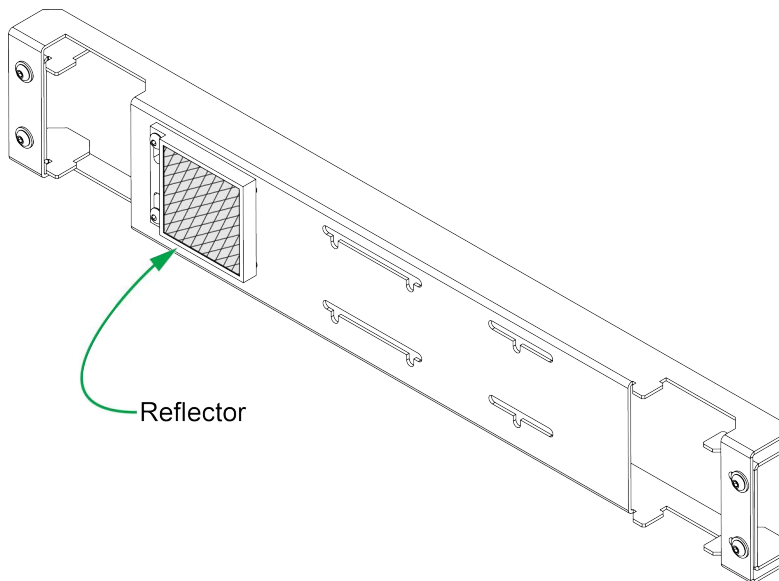

Cable Trolleys

A bundle of power and data cables runs between each dolly and the end of the track. The cable bundle is wrapped in a cable sock and includes a power cable, a network (Ethernet) cable, one or more video cables, plus any other cables required to support the payload.

A series of six-wheeled cable trolleys (Figure 13) travel along the safety rails and suspend the cable bundle, enabling it to be extended and contracted as required. The cable bundle is fastened to the trolleys by breakaway tabs, which may release if the cable becomes snagged. A steel tow cable, which also features breakaway tabs, runs between each pair of cable trolleys to help prevent the cable bundle from being pulled taut.

Figure 13 - Cable Trolley and Tow Cable Breakaway Tab

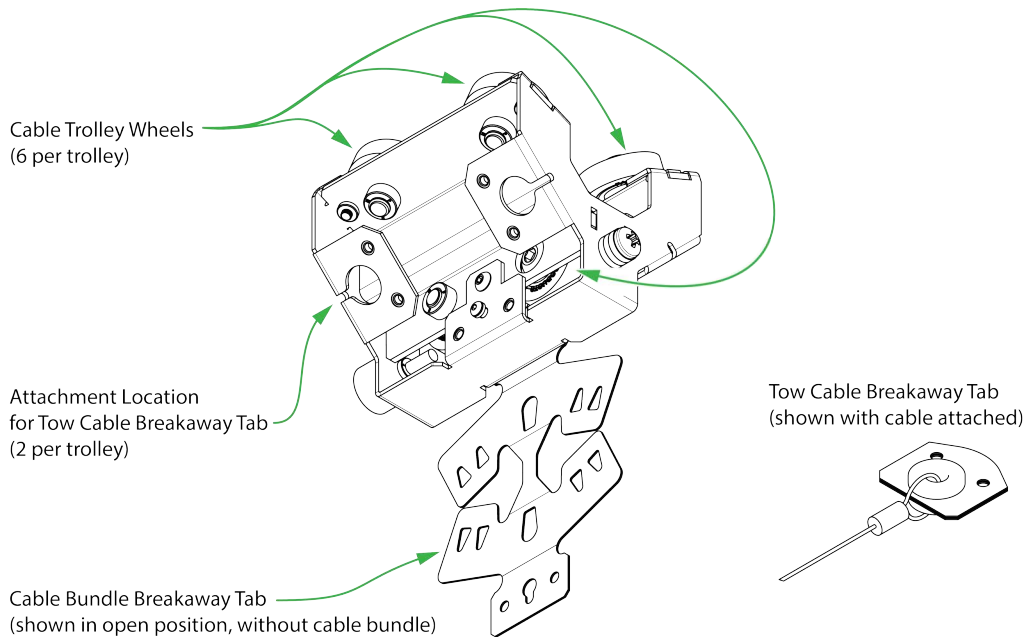

X350 Robotic Pan and Tilt Head

The X350 robotic pan and tilt head (Figure 16) accepts a net payload of up to 15 lbs (6.8 kg) and has a 5 full-color touch screen. The pan and tilt motors have high-resolution encoders, as well as anti-backlash gearing that eliminates play, making the X350 ideal for Virtual Set and Augmented Reality (VS/AR) applications.

Figure 14 - X350 Robotic Head

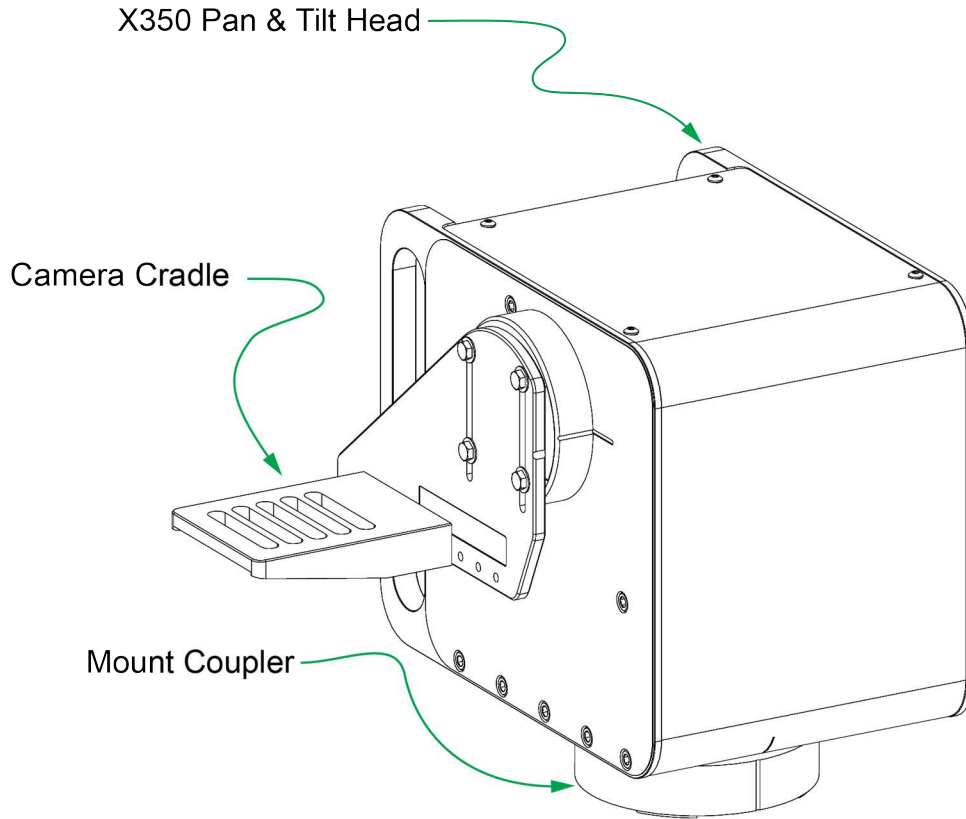
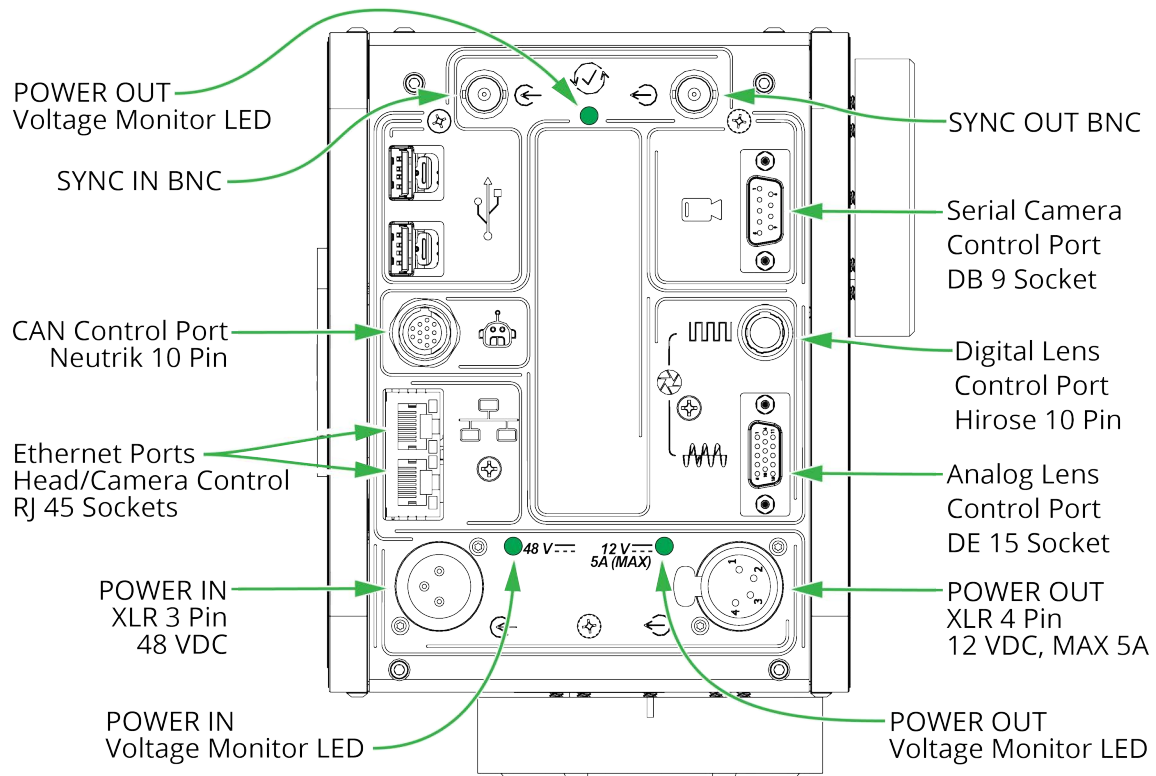

Figure 17 shows the X350 connection panel.

Figure 15 - X350 Pan & Tilt Head - Connection Panel



Furio VR600 Robotic Pan and Tilt Head

The VR600 robotic pan and tilt head ([Figure 16](#)) accepts a net payload of up to 66 lbs (30 kg). The pan and tilt motors have high-resolution encoders, as well as anti-backlash gearing that eliminates play, making the VR600 ideal for Virtual Set and Augmented Reality (VS/AR) applications.

Figure 16 - Furio VR600 Robotic Head

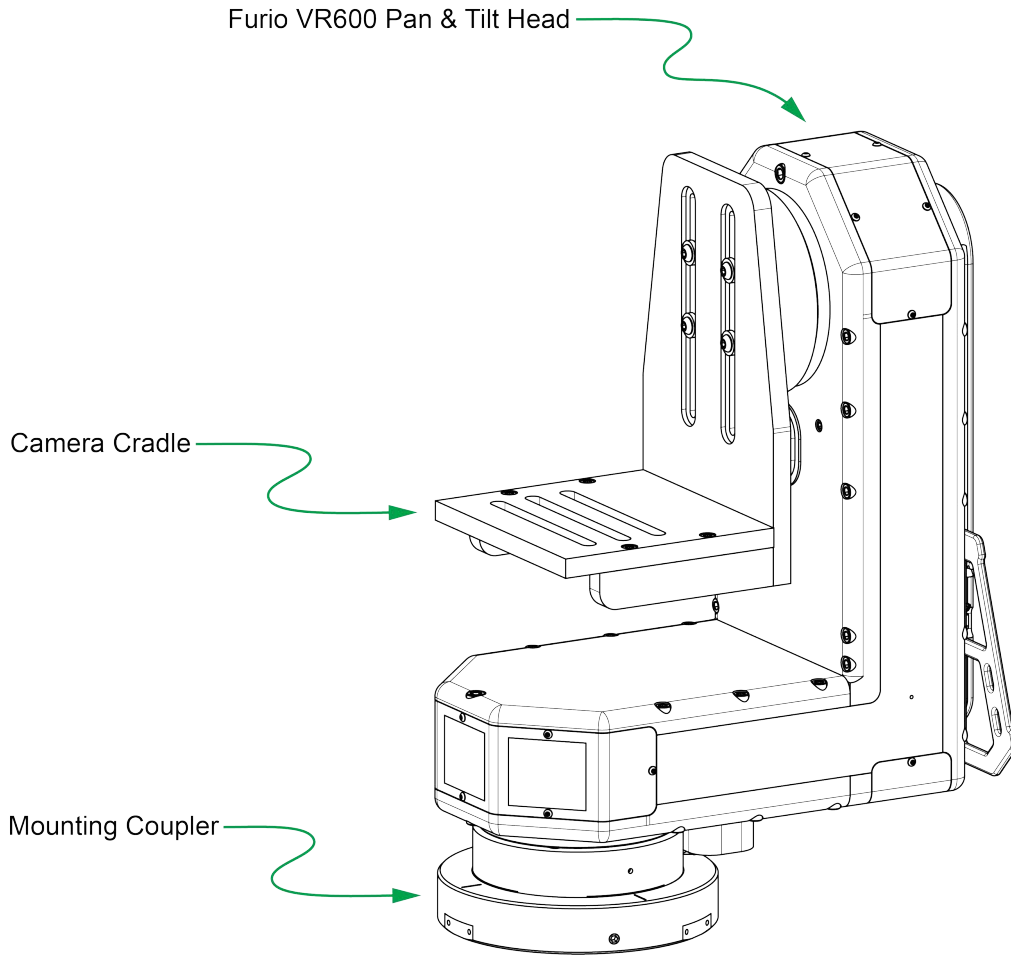

[Figure 17](#) shows the Furio VR600 connection panel.

Figure 17 - Furio VR600 Pan & Tilt Head - Connection Panel

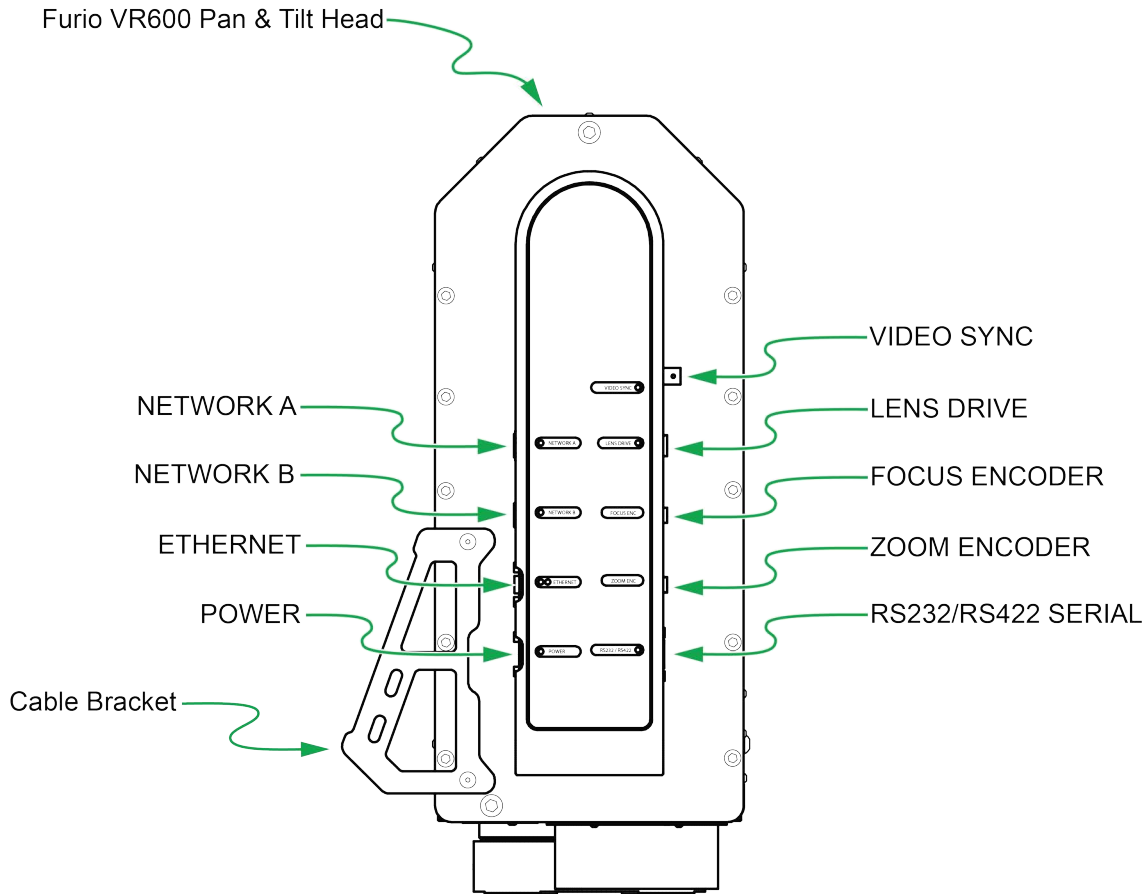

Furio S2 Two-Stage Robotic Lift

The Furio S2 two-stage robotic lift achieves a vertical range of 48.3 cm (19.0"). [Table 3](#) shows the minimum and maximum downward extension, when mounted on a Furio SkyDolly and equipped with either a Furio VR100 or Furio VR600 robotic pan and tilt head:

Table 3 - Minimum and Maximum Downward Extension, with Furio S2 Lift

| Robotic Head | Minimum/Maximum Downward Extension |
|--------------|---|
| Furio X300 | Downward Extension from the top of the dolly rails to the center of the tilt axis: <ul style="list-style-type: none"> • Minimum: 98.4cm (+/- 0.5cm)/38.7" (+/- 0.25") • Maximum: 146.7cm (+/- 0.5cm)/57.7" (+/- 0.25") |
| Furio VR600 | Downward Extension from the top of the dolly rails to the center of the tilt axis: <ul style="list-style-type: none"> • Minimum: 107.5 cm (+/- 0.5 cm) or 42.3" (+/- 0.25") • Maximum: 155.8 cm (+/- 0.5 cm) or 61.3" (+/- 0.25") |

[Figure 18](#) shows the maximum downward extension from the top of the SkyDolly truss to the tilt axis, and to the bottom of the camera cradle, when the Furio S2 Lift is mounted on a Furio SkyDolly and equipped with a Furio VR600 robotic pan and tilt head. For similar drawings and information about other SkyDolly component configurations, see **Furio SkyDolly Site Requirements (5100DR-066-xx)**.

Figure 18 - Furio SkyDolly, showing Maximum Downward Extension with S2_Lift and VR600 Head

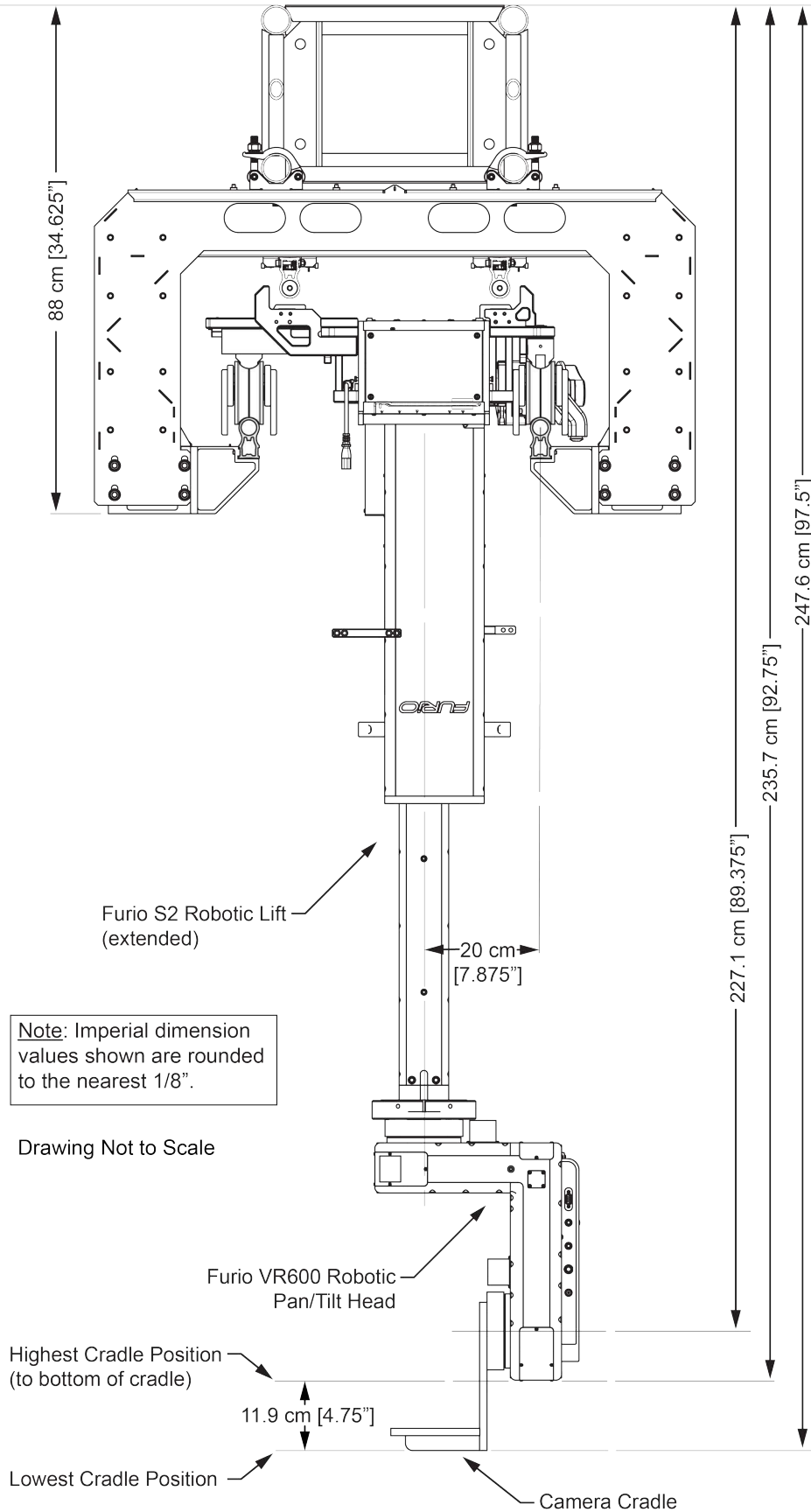

[Figure 19](#) shows the Furio S2 Lift only, highlighting the Blind-Mate Connector, which attaches to a corresponding connector on the SkyDolly Main FRU.

Figure 19 - Furio S2 Lift (fully retracted)

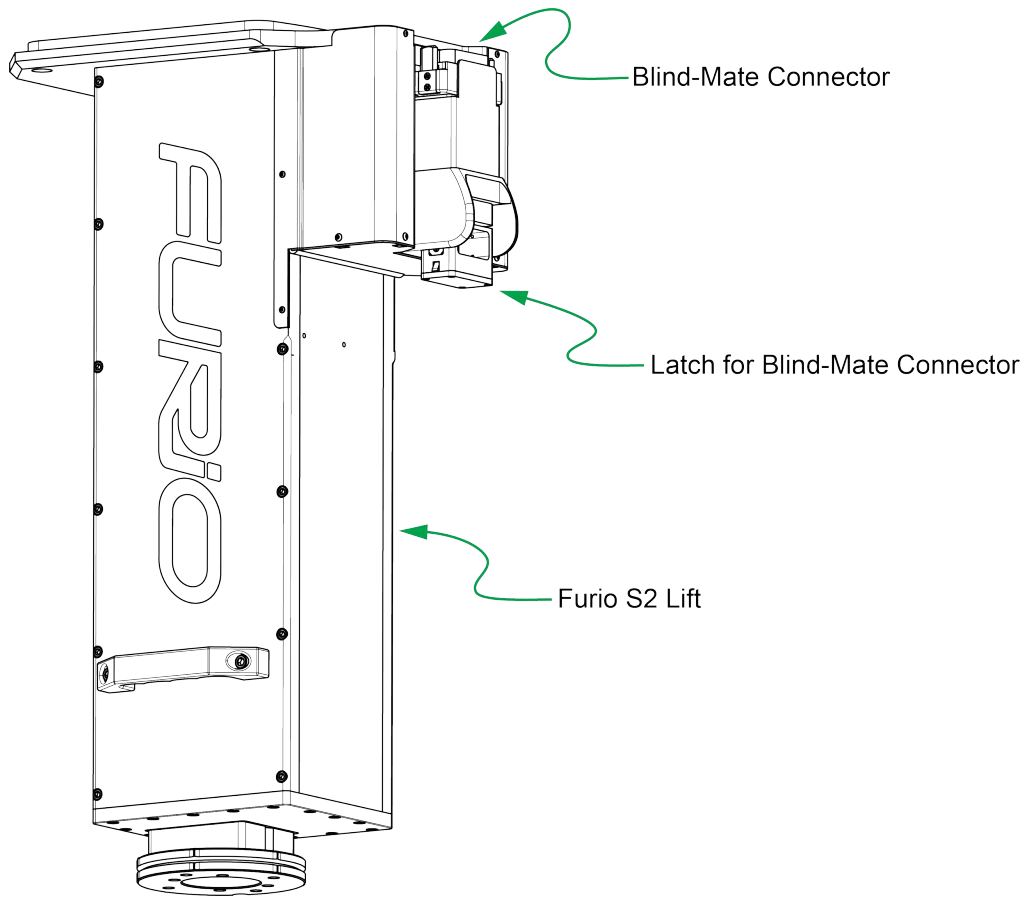

The Main FRU on the dolly is equipped with a manual lift control switch (Figure 20) that enables you to raise or lower the lift locally without a network connection or control system (the network connector for the head, **CAN B**, must be disconnected). The manual lift control switch can lower the lift to its absolute bottom position. This may help provide a better working height for servicing the robotic head, or make the overall size of the lift smaller to facilitate shipping.

Figure 20 - SkyDolly, showing location of the Manual Lift Control Switch

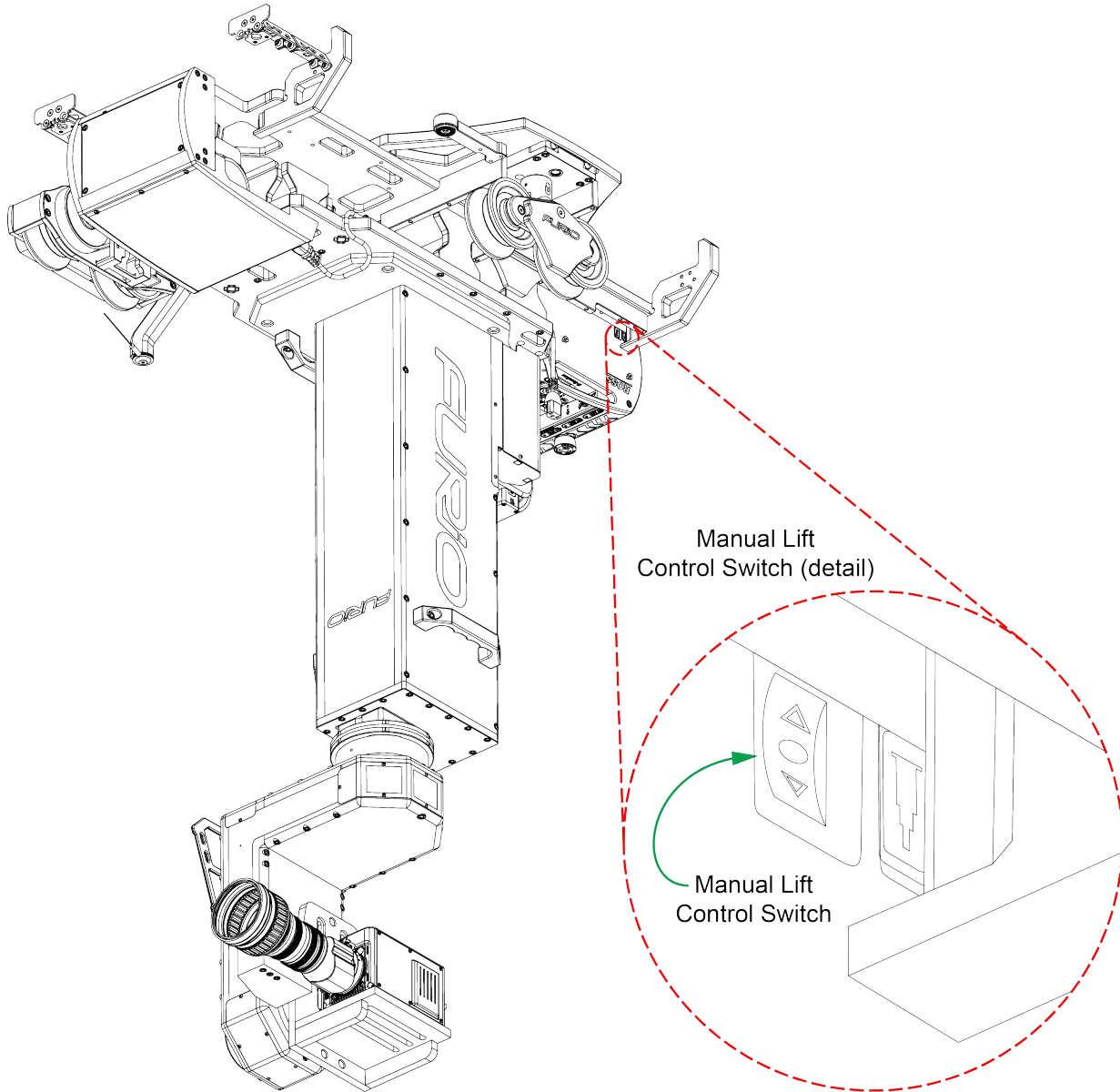

SmartShell Control Application

Furio robots use an open API that allows them to be controlled via a variety of technologies, including Ross Video's SmartShell control application and joystick panel, production switchers such as Ross Video Carbonite, and broadcast automation systems such as Ross Video OverDrive.

The main interface for controlling Ross Video CamBot and Furio robots is SmartShell (Figure 21), an easy-to-use touch-screen application that enables you to control camera systems automatically using stored presets, and manually using a joystick panel and/or buttons in the user interface.

The SmartShell computer comes with a touch screen monitor. You can also use the provided mouse and keyboard.

For detailed information about SmartShell, see the **SmartShell User Guide (5100DR-002-xx)**.

Figure 21 - The SmartShell Control Application (in Matrix Mode), Controlling CamBot and Furio Robots



Ross Video Joystick Panel

You can control Furio camera systems manually using the joystick panel (see [Figure 22](#)). The joystick panel enables you to move multiple axes of a camera system simultaneously, for smooth camera operation.

Figure 22 - Joystick Panel (may not appear exactly as shown)

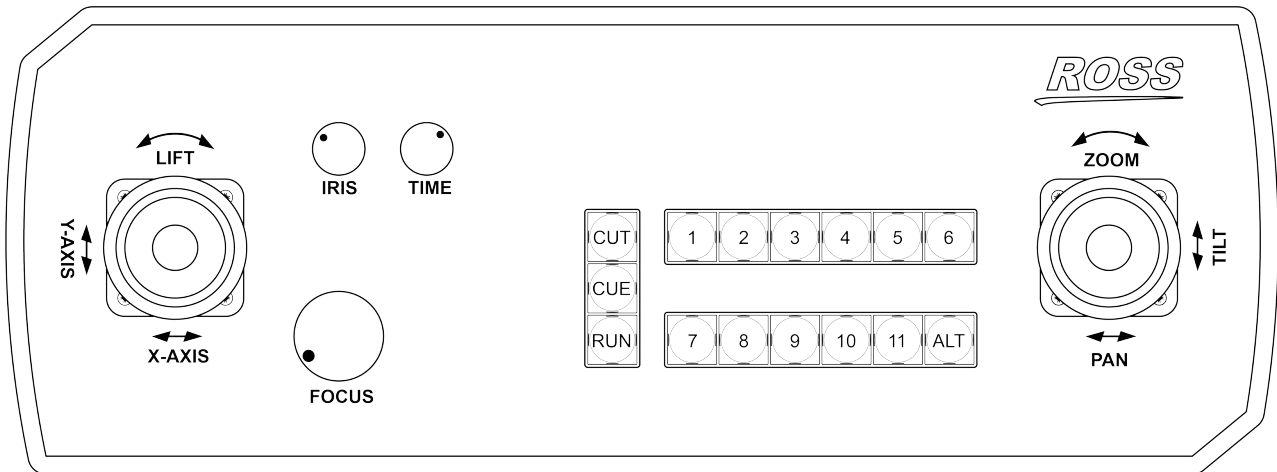

During a show, operators typically use the joystick panel in conjunction with the matrix view in SmartShell. Alternatively, you can use the **Axis Control** panel in SmartShell to control camera systems manually. For more information, see the **SmartShell User Guide (5100DR-002-xx)**.

Accessories

This section describes optional accessories available for your Furio SkyDolly system:

- “**Furio Collision Avoidance System**” on [page 30](#)
- “**Fixed-Height Columns**” on [page 31](#)
- “**CueScript Prompters**” on [page 32](#)
- “**Spare Parts Kits**” on [page 32](#)

Furio Collision Avoidance System

The Furio Collision Avoidance kit is an optional accessory that prevents two SkyDolly dollies on a single track from colliding with each other. It enables the dollies to exchange data about their positions.

Each dolly is configured to slow down and/or stop moving if it is at risk of colliding with another dolly:

- If one dolly is moving towards a stationary dolly, it slows to a stop to avoid colliding.
- If two dollies are moving towards each other, both dollies will slow to a stop to avoid colliding.
- If two dollies are moving the same direction and they get too close, the faster dolly slows down to match the slower dolly's pace.
- If a dolly is performing a move or preset and the collision avoidance features slow or stop it, the move or preset resumes as soon as the way is clear. The dolly moves to the final position but because of the interruption, the move or preset may not perform exactly as expected. You can cancel the rest of the move or preset by stopping the camera system. For information about executing and stopping moves and presets, see the **SmartShell User Guide (5100DR-002)**.

The Furio Collision Avoidance kit (FRO-CA) includes a collision avoidance module ([Figure 23](#)) and associated cables. The module enables the robotic dollies to exchange positional data. If necessary, the dollies automatically limit their movement to prevent collisions.

Collision avoidance requires additional cabling and conformance to specific track layout requirements. For more information about collision avoidance, contact Ross Video.

Figure 23 - Collision Avoidance Module



Fixed-Height Columns

Furio Fixed-Height Columns ([Figure 24](#)) provide elevation between the dolly and the robotic head.

Available heights are as follows:

- 17.8 cm (7") — FRO-FCO-7-SE (not compatible with use of teleprompter)
- 30 cm (12") — FRO-FCO-12-SE
- 76 cm (30") — FRO-FCO-30-SE
- 122 cm (48") — FRO-FCO-48-SE

Figure 24 - 30 cm (12") Fixed-Height Column (FRO-FCO-12-SE)

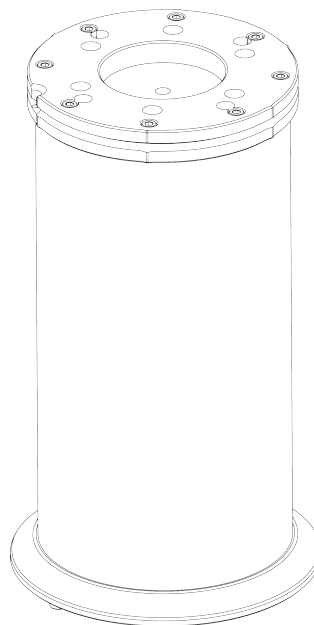

CueScript Prompters

Ross Video sells CueScript™ teleprompters that are fully compatible with our robotic heads. Contact us for more information.

SkyDolly can accommodate teleprompters, but talent monitors are not recommended. This is because teleprompters tend to be mounted closer to the overall payload's center of gravity than talent monitors. Keeping payload weight close to the payload's center of gravity reduces swaying, and results in better shot stability.

Spare Parts Kits

You can order spare parts kits to have readily available in case repairs are required. Having spare parts on hand may eliminate shipping delays when a problem arises, and therefore facilitate faster repairs.

User spare parts kits contain parts that enable an experienced technician to fix basic issues on-site.

Expert spare parts kits contain parts that enable Ross-trained service personnel to fix more serious issues on-site.

Available spare parts kits include the following:

- FRO-SKY-MSP-DLY — Expert Spare Parts Kit for Furio SkyDolly Dolly
- FRO-SKY-MSP-LFT-S2 – Expert Spare Parts Kit for Furio S2 Inverted Lift
- FRO-SKY-USP-DLY – User Spare Parts Kit for Furio SkyDolly Dolly
- FRO-SKY-USP-LFT-S2 – User Spare Parts Kit for Inverted Furio S2 Lift

For more information about spare parts kits for your Furio SkyDolly system, contact Ross Video.

Inspection and Maintenance

This section describes basic cleaning and maintenance procedures for Furio SkyDolly systems. It also provides an inspection and maintenance schedule.

Read each procedure carefully and be certain you understand the steps before you perform them. Please contact Ross Video Technical Support if you have any questions or problems.

IMPORTANT: When servicing or moving equipment, always observe safe handling practices. Get help to move heavy items. Use safe lifting techniques. If working at heights, use proper equipment and techniques. Follow all safety rules of your workplace.

IMPORTANT: This section provides general product information and describes how to perform selected maintenance tasks. It is not a comprehensive service manual and is not a replacement for product commissioning or formal training.

IMPORTANT: Initial setup and commissioning must be performed by Ross Video personnel only. Unauthorized attempts by customers or third parties to unpack, assemble, or commission any portion of the robotics system may result in equipment damage and/or serious injury. Any such attempts may void product warranties.

This section includes the following topics:

- “**Robot General Inspection and Cleaning**” on [page 33](#)
- “**Replacing the Main FRU**” on [page 34](#)
- “**Track Inspection and Maintenance Schedule**” on [page 37](#)

Robot General Inspection and Cleaning

This section describes maintenance tasks for the SkyDolly robot.

IMPORTANT: Always disconnect the power supply before servicing the dolly or any other powered SkyDolly components.

We suggest you periodically perform the following general inspection and cleaning tasks:

- Clean the wheels using a dry foam brush to remove any debris from the soft wheel material, and then wipe with a water-dampened cloth to remove any remaining dirt, dust, or grime.
- Inspect the wheels for excessive wear.
Furio dolly wheels are made of pliable silicone rubber, which wears over time.
If replacement is required, contact Ross Video Technical Support.
- Wipe dust off of external surfaces of the dolly, lift, and head using a slightly damp cloth only. Use only clean water to dampen the cloth. Do not use cleaning agents. Do not wipe near electrical connectors. Do not allow water to penetrate any components.
- Inspect the payload to ensure that no components have shifted and that all fasteners are tightened appropriately.
- Check that all electrical connectors are properly secured.
- Inspect the cable bundle to detect signs of wear. Replace any damaged cables, and replace the cable sock if there are signs of excessive wear.
- Check that cables running to the head and payload are properly dressed. Slowly move the robot through its full range of motion to verify that cables are never pulled taut.

Replacing the Main FRU

The **Main FRU** contains all the control electronics. All network and power connections for the dolly, lift, and head are through the Main FRU's connection panel ([Figure 25](#)).

If the Main FRU malfunctions, you can easily replace it with a different one. This section describes how to remove and replace the Main FRU.

Removing and replacing the Main FRU takes approximately 20 minutes.

Figure 25 - Furio SkyDolly Main FRU Connection Panel

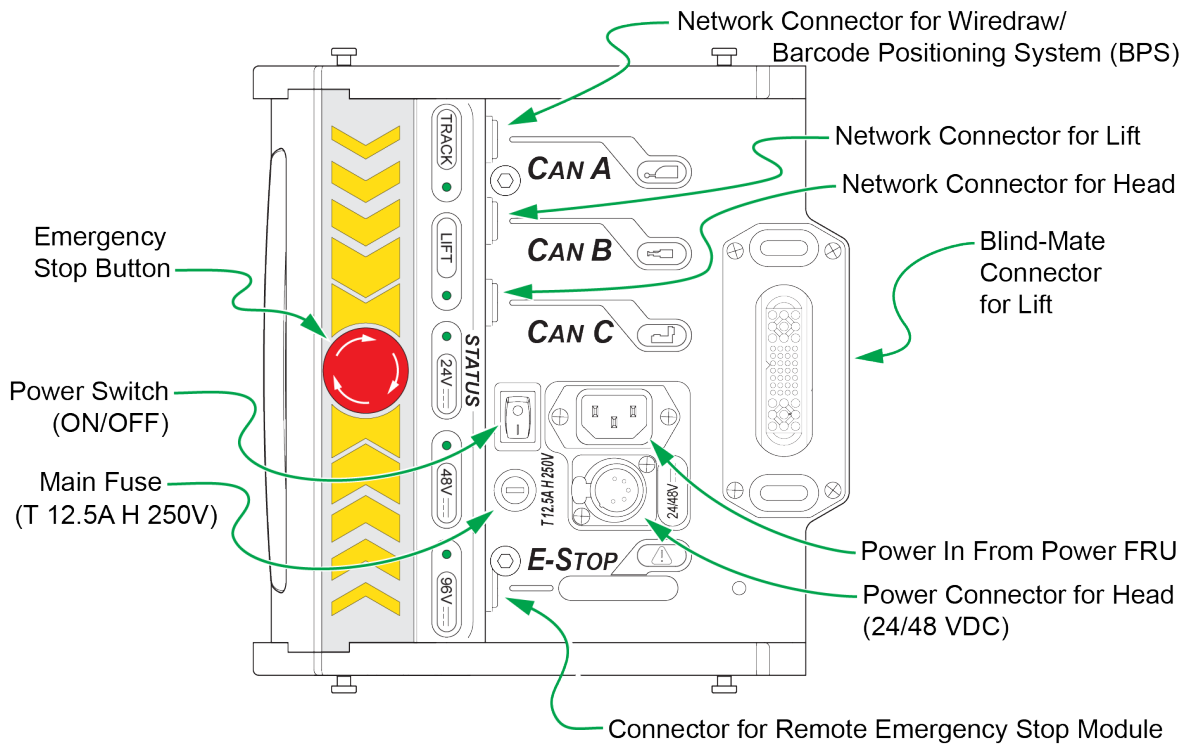

Before you begin:

1. Read all steps and ensure that you understand them.
If you have any questions, contact Ross Video Technical Support.
2. Have the following tools and materials available:
 - 3 mm hex key (also known as an Allen key or hexagonal key wrench)
 - Replacement Main FRU, with appropriate configuration files installed. For more information, contact Ross Video Technical Support.
3. Move the dolly to a location on the track that allows ample space to work.

To remove and replace the Main FRU:

1. Turn off the dolly, and then disconnect the Main FRU's **Power In** cable ([Figure 25](#)).
2. Disconnect all other cables from the Main FRU.
Tip: Ensure that each cable is labeled, so they're easy to reconnect later.
3. If the dolly has a robotic lift, disengage the lift lock connector ([Figure 26](#)).

Figure 26 - Furio SkyDolly with S2 Lift, showing Lift Lock Connector Detail

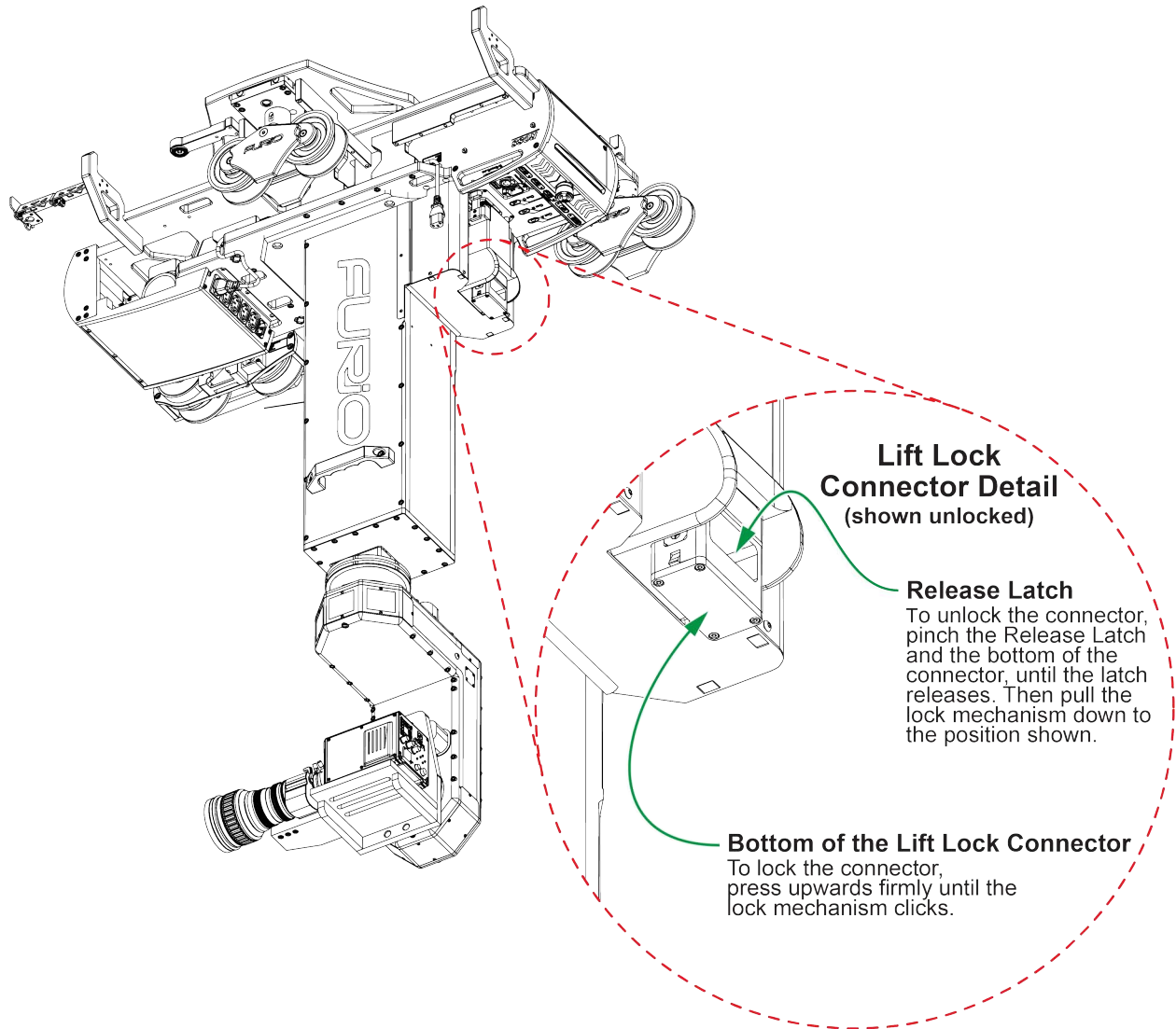

4. Use a 3 mm hex key to remove the four screws that secure the Main FRU to the dolly.
[Figure 27](#) shows the four mounting screws (colored blue in the drawing for illustrative purposes).

Figure 27 - Furio SkyDolly, showing the Four Mounting Screws that Secure the Main FRU

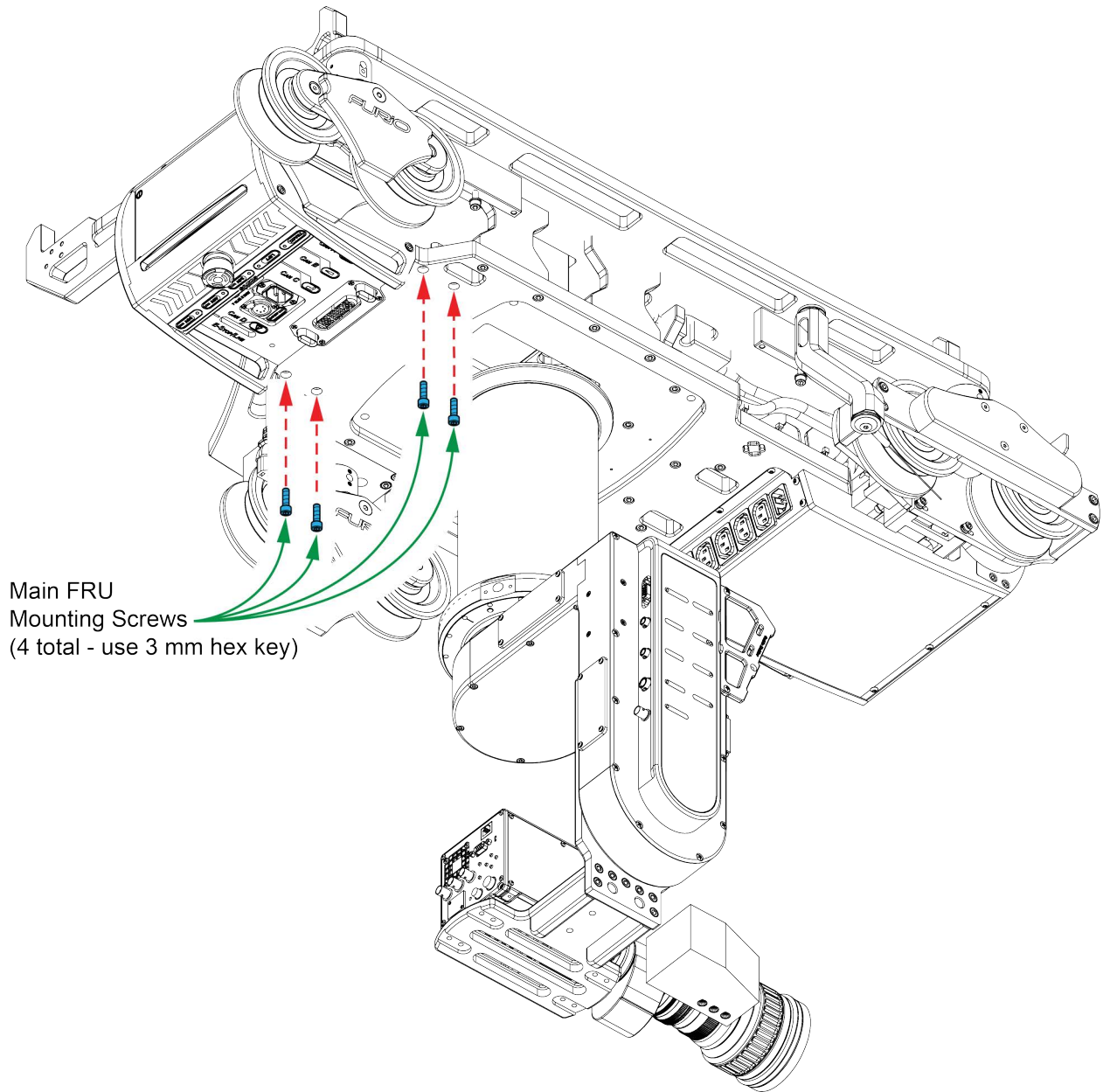

5. Grasp the handles on the Main FRU, and then slowly slide it out from the body of the dolly ([Figure 28](#)).
Tip: Be prepared to catch the Main FRU as it disengages from the body of the dolly.
IMPORTANT: Store the removed Main FRU in a safe location, away from moisture and extreme temperatures.

Figure 28 - Removing the Main FRU from the Furio SkyDolly

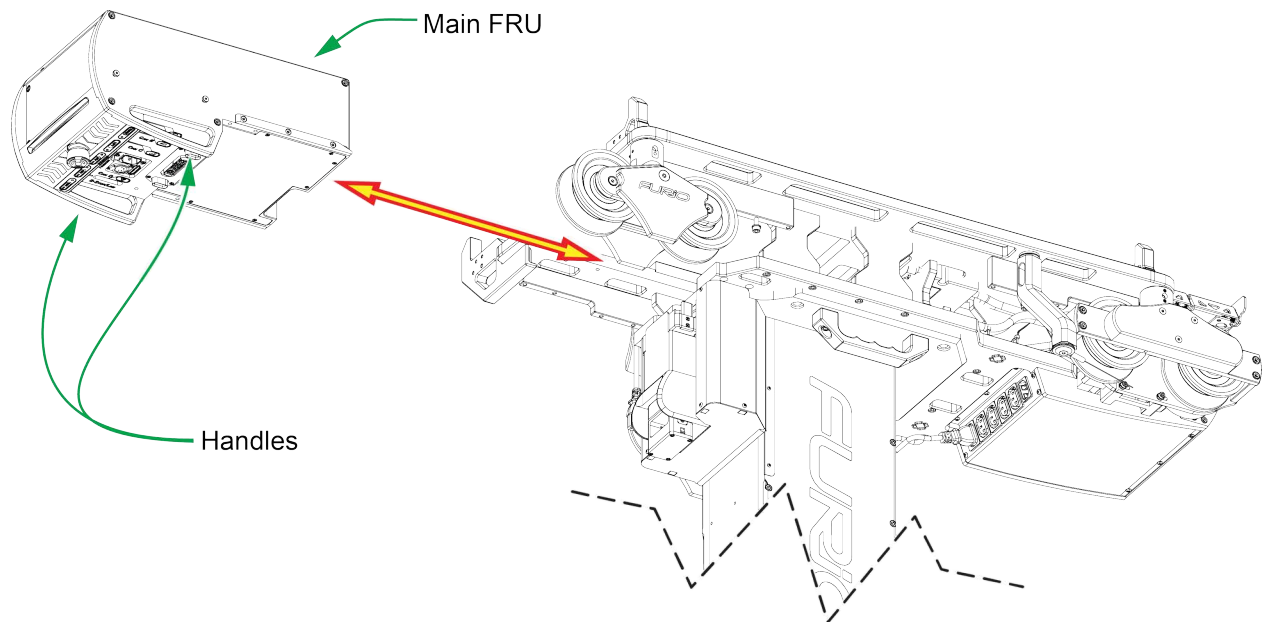

6. Align the new Main FRU with the body of the dolly, and then slowly slide the Main FRU into place. Continue until the Main FRU is fully inserted.
Tip: When the main FRU is fully inserted, the four mounting holes on the top of the dolly base align perfectly with the mounting holes on the Main FRU.
7. Insert and tighten the four mounting screws you removed in **step 4** on **page 36**, using a 3 mm hex key.
8. If the dolly has a robotic lift, engage the lift lock connector (see **Figure 26** on [page 35](#)).
9. Reconnect all cables to the Main FRU.
IMPORTANT: Ensure that all cables are reconnected to their original positions.
10. Turn on the Main FRU and then test the robot's operation.

Track Inspection and Maintenance Schedule

To ensure optimal performance and safety, periodic inspection and maintenance of SkyDolly truss and track components is required.

This section describes inspection and maintenance tasks, and specifies how often to perform them. Some tasks are to be performed monthly. Others are to be performed annually or biennially (every two years). We recommend you maintain an ongoing record of all inspection and maintenance activities.

Ross Video can provide inspection and maintenance services that include the annual and biennial tasks described in this section. For more information, contact Ross Video Technical Support.

WARNING: Failure to perform periodic inspection and maintenance tasks as described in this document may adversely affect the safety of your SkyDolly system and may void product warranties. For more information about customer responsibilities, see the document, "ROSS VIDEO WORLDWIDE TERMS AND CONDITIONS OF SALE", including "ADDENDUM FOR OVERHEAD CAMERA MOTION SYSTEMS".

IMPORTANT: The procedures in this section do not describe inspection of the attachment and/or anchoring of the SkyDolly truss to the structure. The customer is responsible for ensuring that the SkyDolly truss installation remains in compliance with all requirements specified in the document, **Furio SkyDolly Site Requirements (5100DR-066-xx)**.

WARNING: Parts used in the manufacture and assembly of the SkyDolly system were carefully designed and selected to ensure durability and safety. If you replace any fasteners or other parts, be sure to use only genuine parts supplied or approved by Ross Video.

We're Here to Help!

If you have any questions about the Furio SkyDolly system or about the inspection and maintenance tasks described in this section, contact Ross Video Technical Support.

This section includes the following topics:

- "Monthly Inspection and Maintenance" on [page 38](#)
- "Annual Inspection and Maintenance" on [page 39](#)
- "Biennial Inspection and Maintenance" on [page 40](#)
- "Reference Drawings" on [page 42](#)

Note: Drawings in this section are not to scale.

Monthly Inspection and Maintenance

[Table 4](#) describes inspection and maintenance tasks that are to be performed monthly (once per month).

Table 4 - Monthly Inspection and Maintenance Tasks

| Task | Reference and Figure | Description |
|--------------------|---|---|
| Clean dolly rails | Ref 2 in Figure 29 on page 42 | Use a slightly water-dampened cloth to remove dirt, dust, and grime from the dolly rails. |
| Clean dolly wheels | Ref 3 in Figure 30 on page 43 | Use a dry foam brush to remove any debris from the soft wheel material, and then wipe with a water-dampened cloth to remove any remaining dirt, dust, or grime. |

Annual Inspection and Maintenance

[Table 5](#) section describes inspection and maintenance tasks that are to be performed annually (once per year).

Where torque values are specified, use a click-torque wrench that is set to an appropriate range for the torque value.

Table 5 - Annual Inspection and Maintenance Tasks

| Task | Reference and Figure | Description |
|-------------------------------------|--|--|
| Clean safety rails | Ref 1 in Figure 29 on page 42 | Use a slightly water-dampened cloth to remove dirt, dust, and grime from the safety rails. These are the rails upon which the cable trolleys ride. |
| Inspect tow cable breakaway tabs | Ref 5 in Figure 31 on page 44 | Check for cracks, or stressed surface markings Figure 31 on page 44 shows a breakaway tab, shows where breakaway tabs attach to the dolly, and shows where breakaway tabs attach to the ends of cable trolleys. |
| Inspect cable bundle breakaway tabs | Ref 7 in Figure 31 on page 44 | Check for cracks, or stressed surface markings. |
| Inspect lift/column base fasteners | Ref 4 in Figure 31 on page 44 | Re-torque all four screws that secure the lift/column to the dolly base. Fastener type: M10 X 1.5P FHCS Fastener torque: 46 N·m (36 ft-lbs) |
| Inspect head collar fasteners | Ref 6 in Figure 32 on page 45 | Re-torque all three set screws in the side of the collar. Fastener type: M8 X 1.25P Set Screw Fastener torque: 20 N·m (14.8 ft-lbs) |
| Inspect safety tethers | See Description | <p>Safety tethers help prevent equipment from falling. Inspect all safety tether components carefully to ensure that they are fastened securely, do not impede robotic motion, and do not show excessive signs of wear. If you think any component of the safety tether system may be damaged, contact Ross Video Technical Support.</p> <p>Inspect the safety tether components that secure the robotic head to the fixed column, as shown in Figure 34 on page 47. Components to be inspected are as follows:</p> <ul style="list-style-type: none"> • 5110FR-699-xx (SAFETY TETHER, COLUMN TO HEAD) • 85-0040 (CARIBINER, TRIPLE-LOCK) • 5110FR-698-xx (SAFETY TETHER, HEAD LOOP) <p>Inspect the two Payload Safety Tethers that secure the camera cradle and the payload (cameras and lens) to the Column to Head Safety Tether:</p> <ul style="list-style-type: none"> • Figure 35 on page 48 shows how one PAYLOAD SAFETY TETHER (5110FR-695-xx) secures the camera lens to the COLUMN TO HEAD SAFETY TETHER (5110FR-699-xx). • Figure 36 on page 49 shows how a second PAYLOAD SAFETY TETHER (5110FR-695-xx) is attached to the camera cradle secures the camera lens to the COLUMN TO HEAD SAFETY TETHER (5110FR-699-xx). <p>Nylon cable ties are used to dress the Payload Safety Tethers. Do not fasten/bundle any other cables to the Safety Tethers.</p> |

| Task | Reference and Figure | Description |
|---|--|---|
| Inspect head collar safety plate screws | Ref 8 in Figure 33 on page 46 | There are two head collar safety plates. Each has three screws. Re-torque the screws. Fastener type: M5 X 0.8P BHCS Fastener torque: 3.6 N·m (2.7 ft-lbs or 31.7 in-lbs) |
| Inspect dolly wheels | Ref 3 in Figure 30 on page 43 | Check for wear and deterioration. |
| Inspect cable trolley wheels | Ref 6, Figure 31 on page 44 | Check that wheel bearings are free-running, and that rubber tires are not damaged. |

Biennial Inspection and Maintenance

This section describes inspection and maintenance tasks that are to be performed biennially (once every two years).

The biennial tasks are split into two groups, to be performed in alternating years. The first group, described in [Table 6](#), would be performed after years 1, 3, 5, etc. The second group, described in [Table 7](#), would be performed after years 2, 4, 6, etc.

Where torque values are specified, use a click-torque wrench that is set to an appropriate range for the torque value.

Table 6 - Biennial Inspection and Maintenance Tasks to be Performed After Years 1, 3, 5, etc.

| Task | Reference and Figure | Description |
|---|---|---|
| Inspect rail fastening screws After years 1, 3, 5, etc | Ref 11, Figure 37 on page 50 | Wherever a dolly rail meets a rail support frame, two M6 screws fasten the rail to the foot of the bracket. Re-torque the screws. Fastener type: M6 X 1P SHCS Fastener torque: 5.2 N·m (3.8 ft-lbs) |
| Inspect rail foot screws After years 1, 3, 5, etc | Ref 12, Figure 37 on page 50 | Each rail support frame has two adjustable-position feet. Each foot is secured by eight M10 cap screws (four per side). Re-torque the screws. Fastener type: M10 X 1.5 Fastener torque: 16.1 N·m (11.9 ft-lbs) |
| Inspect safety rail coupling screws After years 1, 3, 5, etc | Ref 15, Figure 38 on page 51 | The safety rails, upon which the cable trolleys travel, are joined together by special coupling mechanisms within the rails. At each junction there are metal plates on either side of the rail. Eight M5 screws (four on each side) go through the metal plates and fasten to the coupling mechanism inside the rails. Re-torque the screws to 3.5 N·m (2.6 ft-lbs) |

| Task | Reference and Figure | Description |
|--|---|---|
| Inspect dolly rail coupling screws After years 1, 3, 5, etc | Ref 16, Figure 38 on page 51 | The dolly rails are joined together by special coupling mechanisms within the rails. At each junction there are metal plates on either side of the rail. Eight M5 screws (four on each side) go through the metal plates and fasten to the coupling mechanism inside the rails. Re-torque the screws to 3.5 N·m (2.6 ft-lbs) |

Table 7 - Biennial Inspection and Maintenance Tasks to be Performed After Years 2, 4, 6, etc.

| Task | Reference and Figure | Description |
|---|---|--|
| Inspect safety track bracket screws After years 2, 4, 6, etc. | Ref 9, Figure 37 on page 50 | Safety track brackets secure the safety track rails to the rail support frames. Each side of each safety track bracket has one screw into the rail support frame, and two screws into the rail. Re-torque the screws. Fastener type: M6 X 1P Fastener torque: 14.7 N·m (10.8 ft-lbs) |
| Inspect Truss Connection Bolts After years 2, 4, 6, etc. | Ref 10, Figure 37 on page 50 | Wherever two truss sections meet, four nut and bolt sets fasten them together. Re-torque the nut and bolt sets. Fastener type: M16 X 2 P Fastener torque: 305 N·m (225 ft-lbs) |
| Inspect rail support frame truss clamp top and bottom nuts After years 2, 4, 6, etc. | Ref 13, Figure 38 on page 51 | Each of the clamps that fasten the rail support frame to the truss have a top nut that closes the clamp around the truss pipe, and a bottom bolt and nut that secure the clamp to the rail support frame. Re-torque the top nut and the bottom nut: <ul style="list-style-type: none"> • Top M12 nut torque: 33.9 N·m (25 ft-lbs). <p>WARNING: Do NOT over-torque the top nut! Doing so may compromise the structural integrity of the clamp and/or truss.</p> <ul style="list-style-type: none"> • Bottom M10 nut torque: 29.3 N·m (21.6 ft-lbs) |
| Inspect rail support frame truss clamp body bolts/nuts After years 2, 4, 6, etc. | Ref 14, Figure 38 on page 51 | Each of the clamps that fasten the rail support frames to the truss have two nut and bolt sets that form the hinge pins of the clamp. Re-torque the clamp body nut and bolt sets. Fastener type: M6 X 1P Fastener torque: 9.5 N·m (7.0 ft-lbs) |

Reference Drawings

This section contains drawings and photos to help you locate components that require inspection and maintenance. Task descriptions in [Table 4](#), [Table 5](#), [Table 6](#), and [Table 7](#) refer to these drawings.

Drawings and photos are as follows:

- [Figure 29](#) — “SkyDolly (Box) Truss, Rail Support Frame, and Rails (end view)” on [page 42](#)
- [Figure 30](#) — “SkyDolly (from below)” on [page 43](#)
- [Figure 31](#) — “Cable Trolley Components” on [page 44](#)
- [Figure 32](#) — “Dolly, Column, and Head” on [page 45](#)
- [Figure 33](#) — “Head Collar Safety Plate” on [page 46](#)
- [Figure 34](#) — “Safety Tether Components Securing the Robotic Head to the Column” on [page 47](#)
- [Figure 35](#) — “Payload Safety Tether Secures the Camera and Lens” on [page 48](#)
- [Figure 36](#) — “Payload Safety Tether Secures the Camera Cradle” on [page 49](#)
- [Figure 37](#) — “Box Truss Connection and Rail Fastening” on [page 50](#)
- [Figure 38](#) — “Rail Support Frame Clamps and Rail Couplings” on [page 51](#)

Figure 29 SkyDolly (Box) Truss, Rail Support Frame, and Rails (end view)

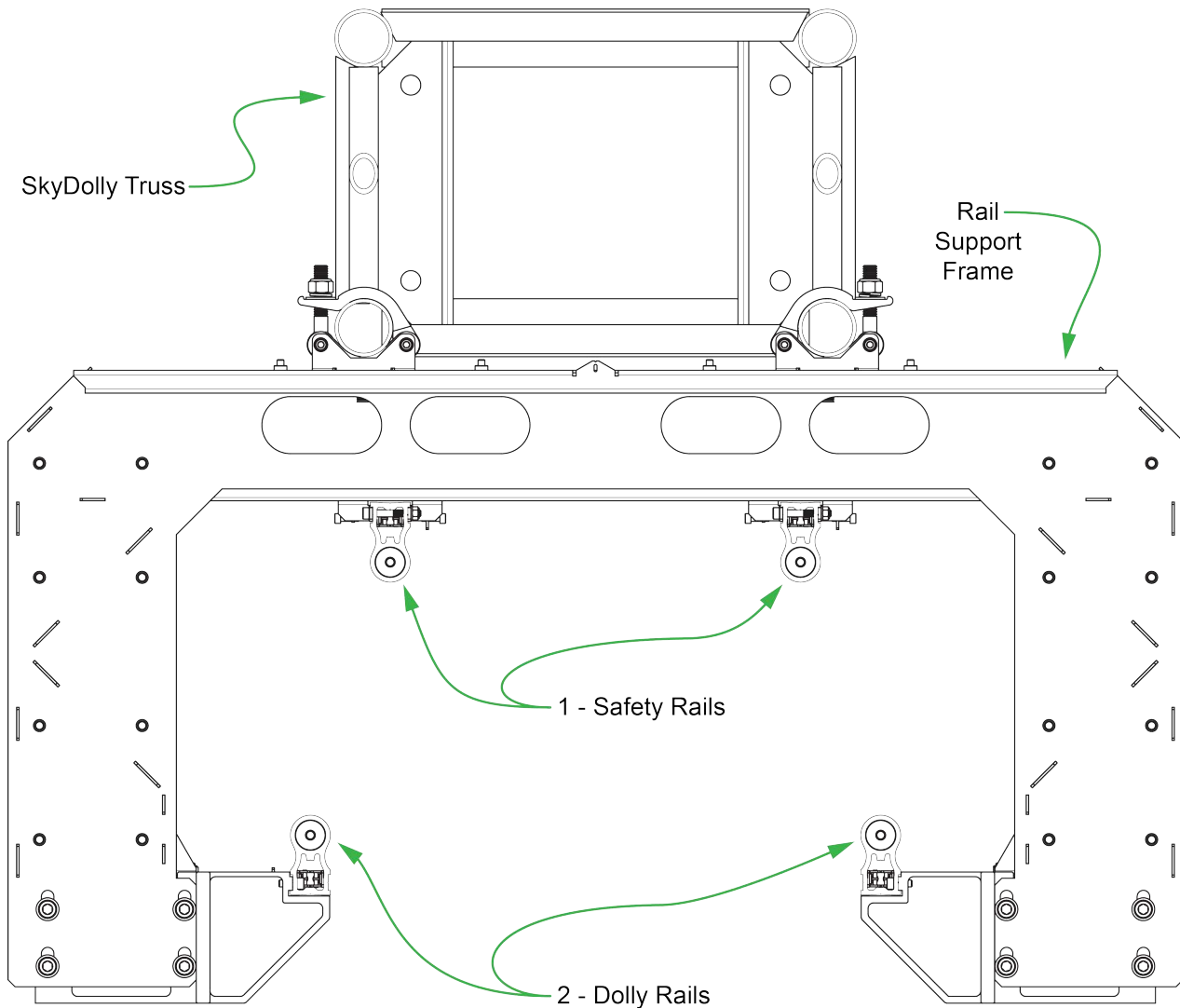

Figure 30 SkyDolly (from below)

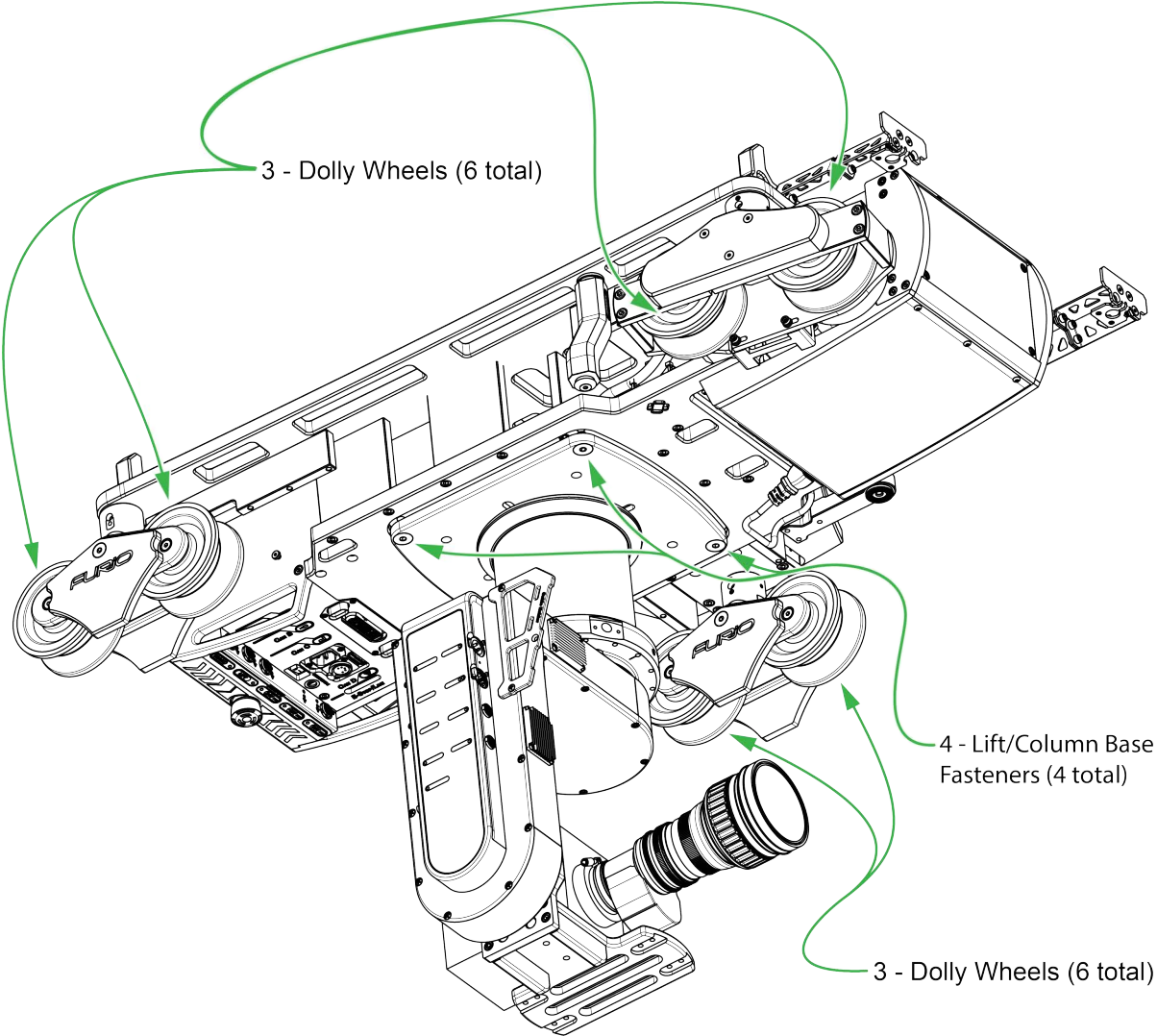

Figure 31 Cable Trolley Components

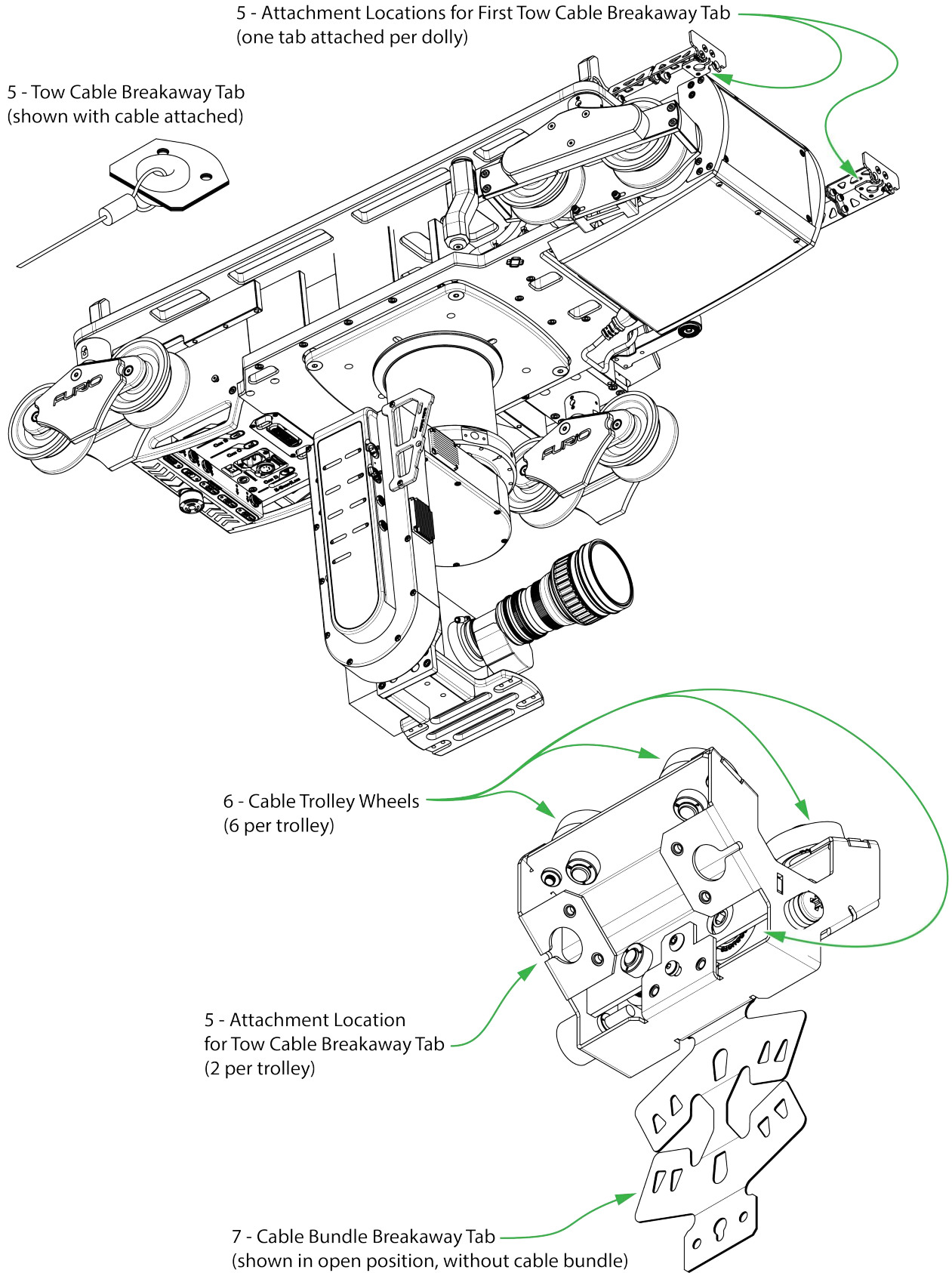
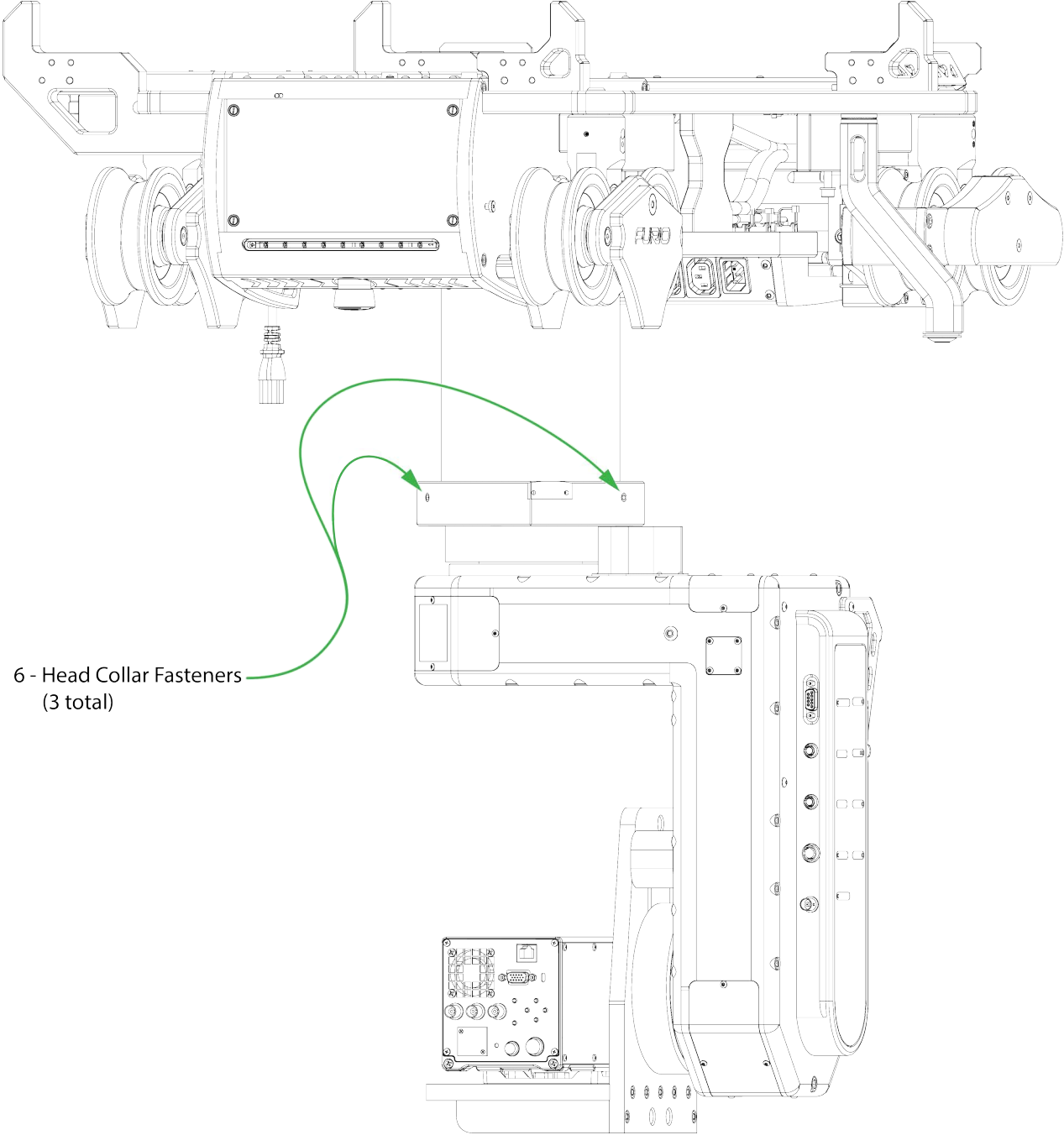
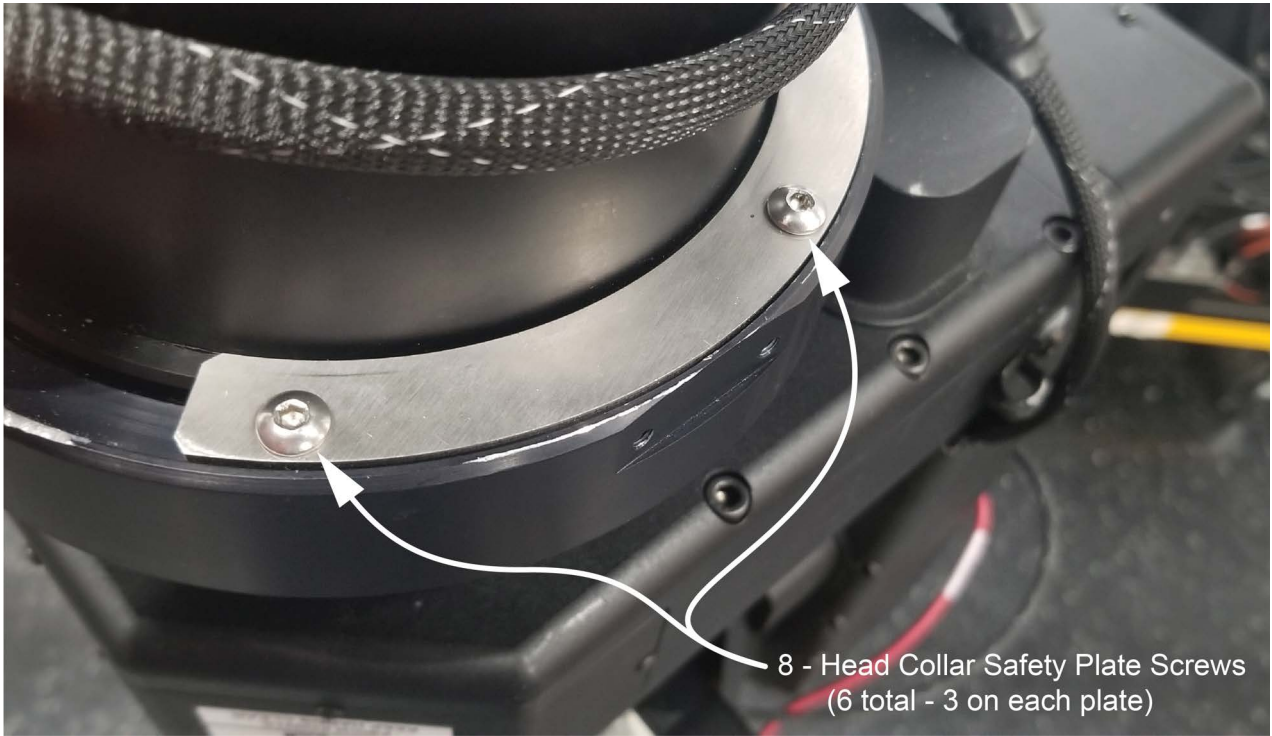

Figure 32 Dolly, Column, and Head



6 - Head Collar Fasteners
(3 total)

Figure 33 Head Collar Safety Plate



8 - Head Collar Safety Plate Screws
(6 total - 3 on each plate)

Figure 34 Safety Tether Components Securing the Robotic Head to the Column

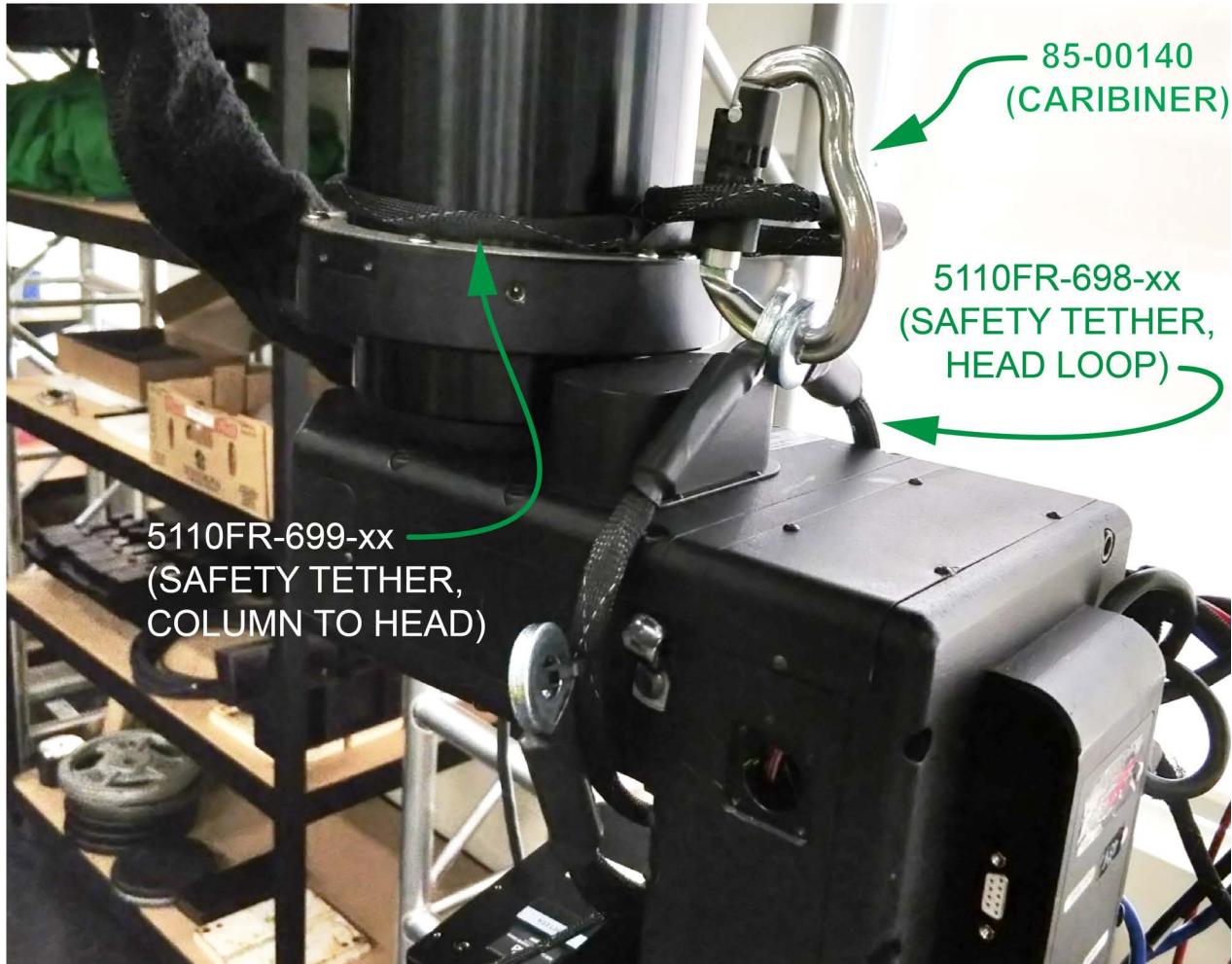

Figure 35 Payload Safety Tether Secures the Camera and Lens

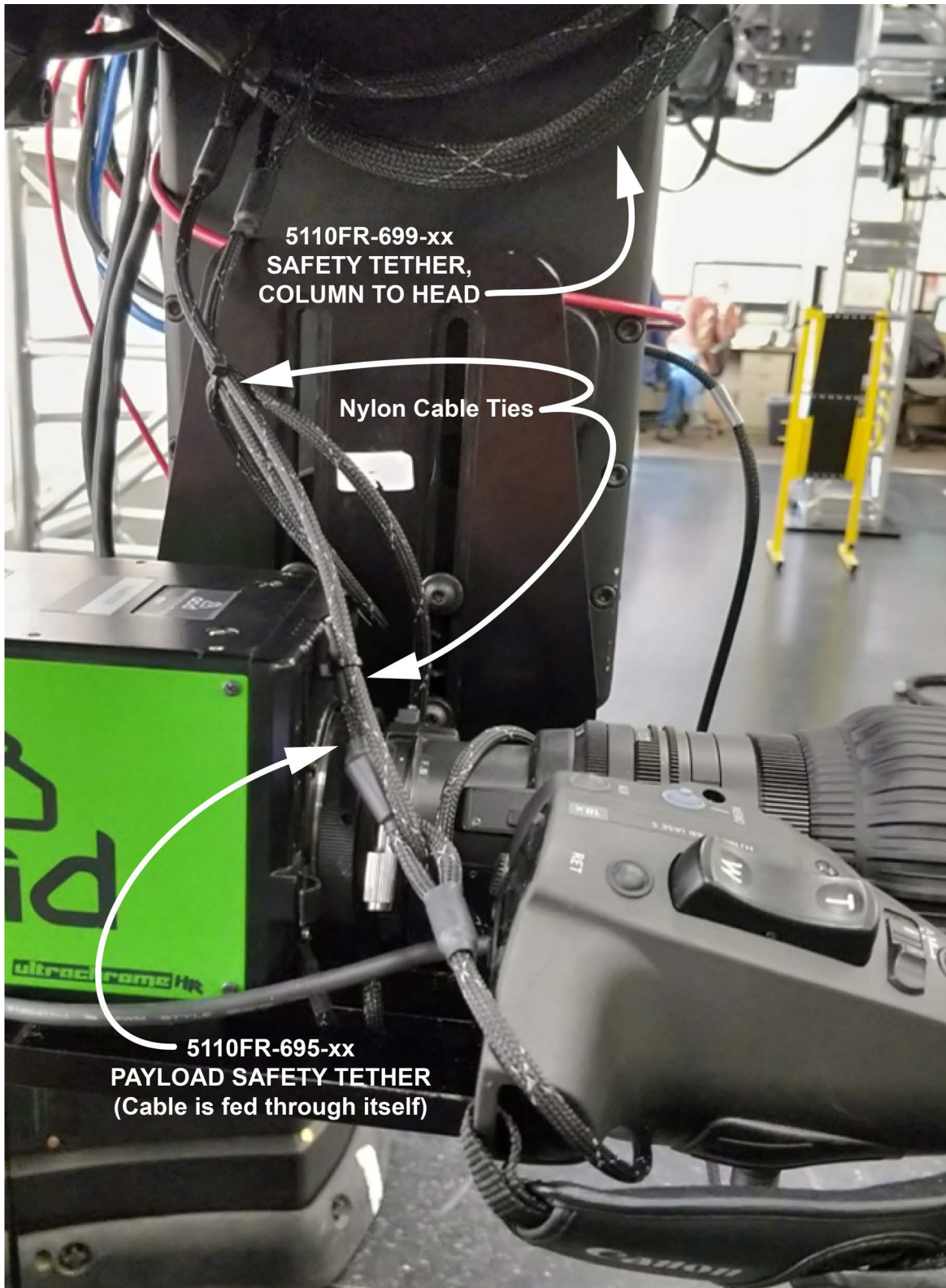

Figure 36 Payload Safety Tether Secures the Camera Cradle



Figure 37 Box Truss Connection and Rail Fastening

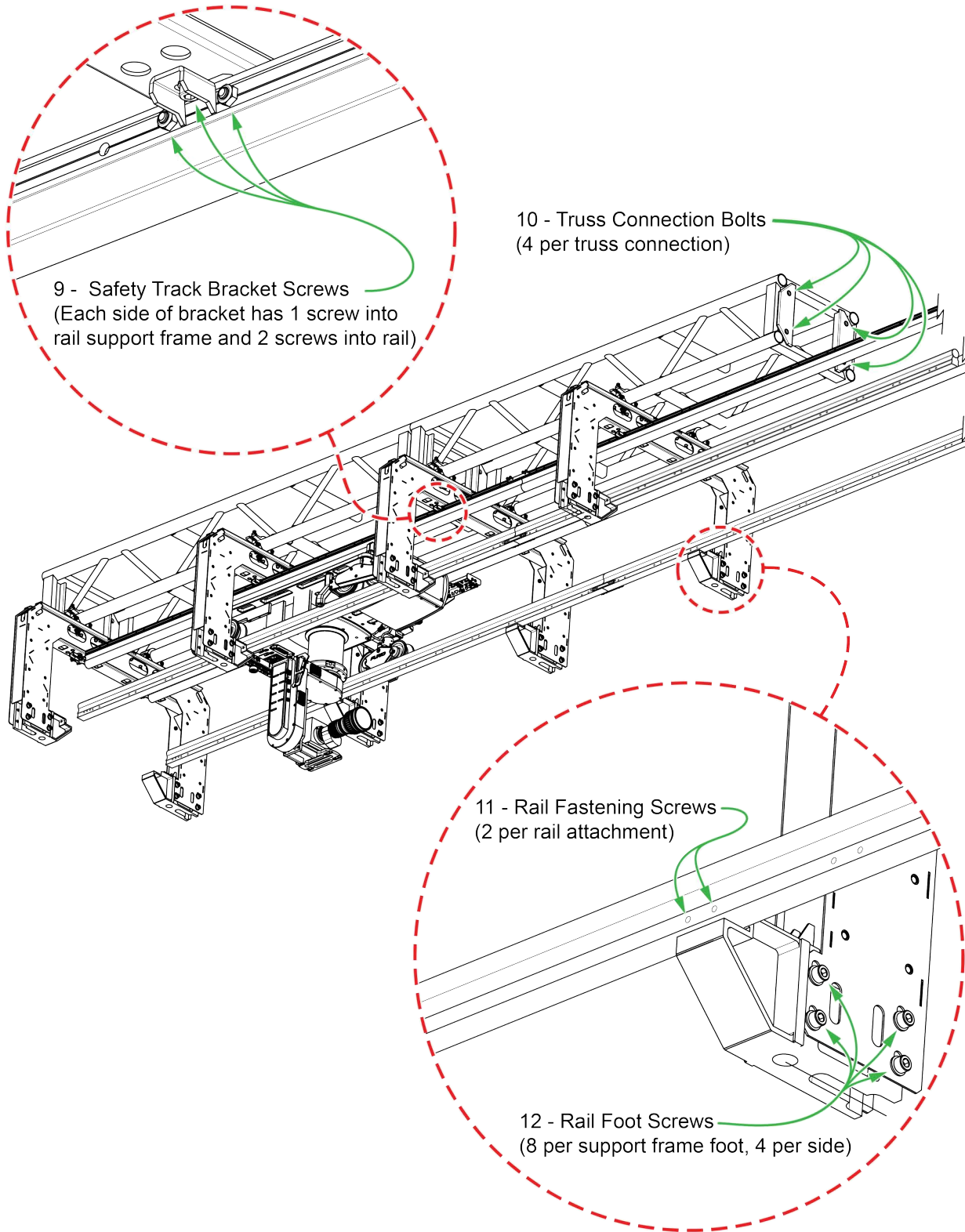
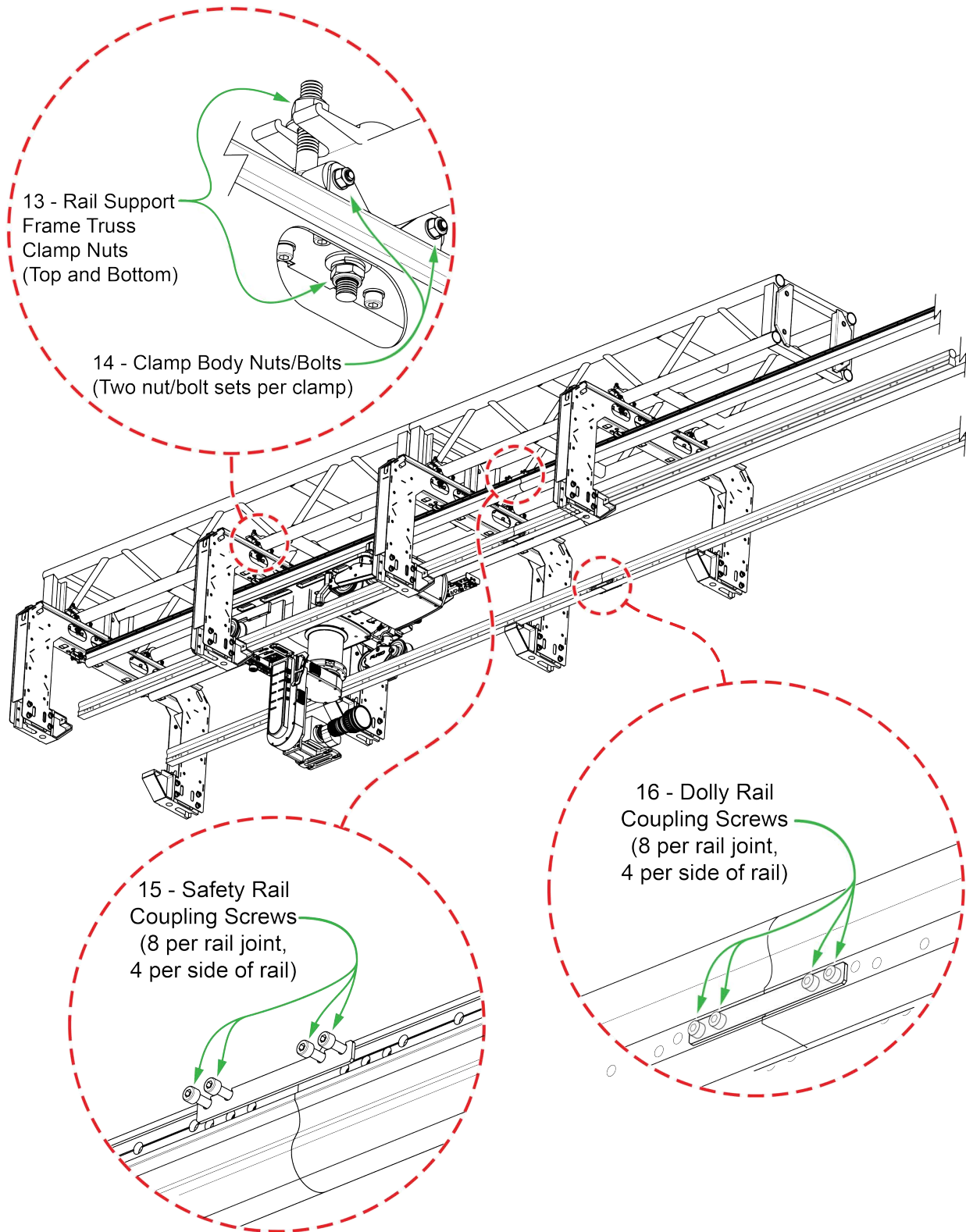

Figure 38 Rail Support Frame Clamps and Rail Couplings



Technical Specifications

Each SkyDolly robot package includes one or more robotic components (dolly, lift, head) and may also include a fixed-height column. All other system components and accessories are sold separately. Truss and track layouts are custom-designed for each installation.

Full robot packages include a SkyDolly, a robotic pan/tilt head, and either a robotic lift or a fixed-height column.

Upgrade packages include one or more supplemental robotic components that enable customers to enhance an existing robot. Once upgraded, the robot consists of the same components as one of the full robot packages.

SkyDolly robot packages are as follows:

- **FRO-SKY-X350-DLY** — Full robot package consisting of an X350 pan/tilt head attached to a Furio SkyDolly via a fixed-height column.
- **FRO-SKY-X350-FULL-S2** — Full robot package consisting of an X350 pan/tilt head attached to a Furio SkyDolly via a Furio S2 two-stage robotic lift.
- **FRO-SKY-VR600-DLY** — Full robot package consisting of a Furio VR600 pan/tilt head attached to a Furio SkyDolly via a fixed-height column.
- **FRO-SKY-VR600-FULL-S2** — Full robot package consisting of a Furio VR600 pan/tilt head attached to a Furio SkyDolly via a Furio S2 two-stage robotic lift.
- **FRO-SKY-DLY-UPG** — Upgrade package consisting of a Furio SkyDolly plus fixed-height column, without a robotic head. This package is suitable for customers who already own a Furio VR100 or VR600 robotic head and want to upgrade to a full suspended-track SkyDolly system.
- **FRO-SKY-FULL-S2-UPG** — Upgrade package consisting of a Furio SkyDolly plus Furio S2 two-stage lift, without a robotic head. This package is suitable for customers who already own a Furio VR100 or VR600 robotic head and want to upgrade to a full suspended-track SkyDolly system.
- **FRO-SKY-S2-UPG** — Upgrade package consisting of a Furio S2 two-stage lift only. This package is suitable for customers who already own a Furio SkyDolly system and want to add a robotic lift to a dolly.

This section provides technical specifications for each of the full SkyDolly robot packages, as well as SkyDolly track and wiredraw components:

- “**FRO-SKY-X350-DLY Product Package**” on [page 53](#)
- “**FRO-SKY-X350-FULL-S2 Product Package**” on [page 54](#)
- “**FRO-SKY-X350-FULL-S2 Product Package**” on [page 54](#)
- “**FRO-SKY-VR600-DLY Product Package**” on [page 55](#)

FRO-SKY-X350-DLY Product Package

This packages features an X350 pan/tilt head attached to a Furio SkyDolly via a fixed-height column.

Table 8 - Technical Specifications for the FRO-SKY-X350-DLY Product Package

| Component | Property | Description / Value |
|----------------|--|--|
| Robotic Head | Robotic Head Type | X350 robotic pan and tilt head |
| | Maximum Net Payload | 6.8 kg (15 lbs) |
| | Minimum/Maximum Pan Speed | 0.001 - 45 degrees per second |
| | Minimum/Maximum Tilt Speed | 0.001 - 45 degrees per second |
| | Pan/Tilt Repeatability | <0.02 degrees |
| | Pan/Tilt Angular Range | ±179° pan range and ±90° tilt range |
| Dolly/Head | Maximum vertical distance from top of dolly rails to center of tilt axis. Dolly + X350 Head | Varies by fixed-column height: <ul style="list-style-type: none"> • 17.8 cm (7") column: 54.5 cm (21.5") • 30.5 cm (12") column: 67.2 cm (26.5") • 76.2 cm (30") column: 112.9 cm (44.5") • 121.9 cm (48") column: 158.6 cm (62.5") Values include 11 mm (0.43") rail height adjustment range on rail frames. |
| | Position Tracking for VS/AR | Yes |
| Furio SkyDolly | Track Repeatability | <1 cm (absolute positioning) |
| | Dolly Dimensions (Length x Width x Height) | Length: 103.7 cm Width: <ul style="list-style-type: none"> • Wiredraw 65.4 cm if wiredraw post is on same side as drive wheels, or 63.4 cm if wiredraw post is on opposite side. • BPS BPS (Inner Rail) 65.9 cm, BPS (Outer Rail) 68cm Height (dolly only, no column, lift, or head): 23.9 cm. |
| | Maximum Track Speed | Speed depends on payload and track length: <ul style="list-style-type: none"> • 1 - 2.5 m/s (36 - 96 in/s) on straight track • 0.5 - 1 m/s (18 - 39 in/s) on curved track |

FRO-SKY-X350-FULL-S2 Product Package

This package features an X350 pan/tilt head attached to a Furio SkyDolly via a Furio S2 two-stage robotic lift.

Table 9 - Technical Specifications for the FRO-SKY-X350-FULL-S2 Product Package

| Component | Property | Description / Value |
|-----------------|--|--|
| Robotic Head | Robotic Head Type | Furio VR100 robotic pan and tilt head |
| | Maximum Net Payload | 20 kg (44 lbs) |
| | Maximum Prompter Size | 38 cm (15") |
| | Minimum/Maximum Pan Speed | 0.001 - 60 degrees per second |
| | Minimum/Maximum Tilt Speed | 0.001 - 60 degrees per second |
| | Pan/Tilt Repeatability | <0.02 degrees |
| | Pan/Tilt Angular Range | ±179° pan range and ±90° tilt range |
| Furio S2 Lift | Lift Type | Two-stage |
| | Lift Total Range | 48.3 cm (19") |
| Dolly/Lift/Head | Vertical distance from top of dolly rails to center of tilt axis. SkyDolly + S2 Lift + X350 Head | Maximum: 152.1 cm (59.9") Minimum: 103.8 cm (40.5") Values include 11 mm (0.43") rail height adjustment range on rail frames. |
| | Position Tracking for VS/AR | Yes |
| Furio SkyDolly | Track Repeatability | <1 cm (absolute positioning) |
| | Dolly Dimensions (Length x Width x Height) | Length: 103.7 cm Width: • Wiredraw 65.4 cm if wiredraw post is on same side as drive wheels, or 63.4 cm if wiredraw post is on opposite side. • BPS BPS (Inner Rail) 65.9 cm, BPS (Outer Rail) 68cm Height (dolly only, no column, lift, or head): 23.9 cm without. |
| | Maximum Track Speed | Speed depends on payload and track length: • 1 - 2.5 m/s (36 - 96 in/s) on straight track • 0.5 - 1 m/s (18 - 39 in/s) on curved track |

FRO-SKY-VR600-DLY Product Package

This package features a Furio VR600 pan/tilt head attached to a Furio SkyDolly via a fixed-height column.

Table 10 - Technical Specifications for the FRO-SKY-VR600-DLY Product Package

| Component | Property | Description / Value |
|----------------|---|--|
| Robotic Head | Robotic Head Type | Furio VR600 robotic pan and tilt head |
| | Maximum Net Payload | 30 kg (66 lbs) |
| | Maximum Prompter Size | 48 cm (19") |
| | Minimum/Maximum Pan Speed | 0.001 - 90 degrees per second |
| | Minimum/Maximum Tilt Speed | 0.001 - 90 degrees per second |
| | Pan/Tilt Repeatability | <0.02 degrees |
| | Pan/Tilt Angular Range | ±358° pan range and ±90° tilt range |
| Dolly/Head | Maximum vertical distance from top of dolly rails to center of tilt axis. Dolly + VR600 Head | Varies by fixed-column height: <ul style="list-style-type: none"> • 17.8 cm (7") column: 54.5 cm (21.5") • 30.5 cm (12") column: 67.2 cm (26.5") • 76.2 cm (30") column: 112.9 cm (44.5") • 121.9 cm (48") column: 158.6 cm (62.5") Values include 11 mm (0.43") rail height adjustment range on rail frames. |
| | Position Tracking for VS/AR | Yes |
| Furio SkyDolly | Track Repeatability | <1 cm (absolute positioning) |
| | Dolly Dimensions (Length x Width x Height) | Length: 103.7 cm Width: <ul style="list-style-type: none"> • Wiredraw 65.4 cm if wiredraw post is on same side as drive wheels, or 63.4 cm if wiredraw post is on opposite side. • BPS BPS (Inner Rail) 65.9 cm, BPS (Outer Rail) 68cm Height (dolly only, no column, lift, or head): 26.6 cm with wiredraw post, or 23.9 cm without. |
| | Maximum Track Speed | Speed depends on payload and track length: <ul style="list-style-type: none"> • 1 - 2.5 m/s (36 - 96 in/s) on straight track • 0.5 - 1 m/s (18 - 39 in/s) on curved track |

FRO-SKY-VR600-FULL-S2 Product Package

This package features a Furio VR600 pan/tilt head attached to a Furio SkyDolly via a Furio S2 two-stage robotic lift.

Table 11 - Technical Specifications for the FRO-SKY-VR600-FULL-S2 Product Package

| Component | Property | Description / Value |
|-----------------|---|--|
| Robotic Head | Robotic Head Type | Furio VR600 robotic pan and tilt head |
| | Maximum Net Payload | 30 kg (66 lbs) |
| | Maximum Prompter Size | 48 cm (19") |
| | Minimum/Maximum Pan Speed | 0.001 - 90 degrees per second |
| | Minimum/Maximum Tilt Speed | 0.001 - 90 degrees per second |
| | Pan/Tilt Repeatability | <0.02 degrees |
| | Pan/Tilt Angular Range | ±358° pan range and ±90° tilt range |
| Furio S2 Lift | Lift Type | Two-stage |
| | Lift Total Range | 48.3 cm (19") |
| Dolly/Lift/Head | Vertical distance from top of dolly rails to center of tilt axis. SkyDolly + S2 Lift + VR600 Head | Maximum: 156.3 cm (61.5") Minimum: 106.9 cm (42.1") Values include 11 mm (0.43") rail height adjustment range on rail frames. |
| | Position Tracking for VS/AR | Yes |
| Furio SkyDolly | Track Repeatability | <1 cm (absolute positioning) |
| | Dolly Dimensions (Length x Width x Height) | Length: 103.7 cm Width: • Wiredraw 65.4 cm if wiredraw post is on same side as drive wheels, or 63.4 cm if wiredraw post is on opposite side. • BPS BPS (Inner Rail) 65.9 cm, BPS (Outer Rail) 68cm Height (dolly only, no column, lift, or head): 26.6 cm with wiredraw post, or 23.9 cm without. |
| | Maximum Track Speed | Speed depends on payload and track length: • 1 - 2.5 m/s (36 - 96 in/s) on straight track • 0.5 - 1 m/s (18 - 39 in/s) on curved track |

SkyDolly Track, BPS, and Wiredraw Components



This section lists technical specifications for SkyDolly track and wiredraw components. It includes only specifications that are useful to users of SkyDolly systems that are already installed. For detailed site requirements and measurements related to the installation of SkyDolly truss, track, and wiredraw components, see **Furio SkyDolly Site Requirements (5100DR-066-xx)**.

Table 12 - Technical Specifications for Furio Track and BPS Components

| Component | Property | Description / Value |
|-----------------------------|----------------------|---|
| Track | Maximum Track Length | 30m (98') |
| | Dolly Track Width | 50 cm (14.7") between center of each rail. |
| BPS Unit | BPS Tape Lengths | Barcode tapes are available in the following lengths: <ul style="list-style-type: none"> › 10 meters (Product Code FRO-BPS-TAPE-10) › 20 meters (Product Code FRO-BPS-TAPE-20) › 30 meters (Product Code FRO-BPS-TAPE-30) › 40 meters (Product Code FRO-BPS-TAPE-40) › 50 meters (Product Code FRO-BPS-TAPE-50) › 70 meters (Product Code FRO-BPS-TAPE-70) <p>Ensure barcode tape is free of wrinkles and mechanical tension.</p> |
| | Power Requirements | Voltage rating: 18 to 30Vdc Current rating: 300mA Max |
| 15 m SkyDolly Wiredraw Unit | Wiredraw range | Maximum 15 m (49.2') from wiredraw spool to attachment point on dolly. WARNING: The wiredraw unit may become permanently damaged if the wiredraw cable reaches the end of its range. |
| | Power Requirements | Wiredraw units are powered by the Controller Area Network (CAN bus). No additional power supply is required. |
| 30 m SkyDolly Wiredraw Unit | Wiredraw range | Maximum 30 m (98.4') from wiredraw spool to attachment point on dolly. WARNING: The wiredraw unit may become permanently damaged if the wiredraw cable reaches the end of its range. |
| | Power Requirements | Wiredraw units are powered by the Controller Area Network (CAN bus). No additional power supply is required. |

Electrical and Environmental Specifications

The Furio Camera Motion Systems series includes three systems—Furio Floor-Mount, Furio BlackBird, and Furio SkyDolly—designed to carry and control camera and teleprompter payloads, offering precise pan, tilt, zoom, and path-following capabilities for dynamic shots in various environments like film production, live events, and TV studios. All systems share common components, with the primary difference being the dolly's mechanical design.

| | Furio Floor-Mount Rail System | Furio SkyDolly Ceiling-Mounted Rail System | Furio BlackBird Elevation System |
|---|---|--|--|
| Full system view |  <p>For more information on Furio SkyDolly Systems, refer to the Technical Manual for Furio Dolly Systems (5100DR-043-04).</p> |  |  <p>For more information on Furio SkyDolly Systems, refer to the Technical Manual for BlackBird C2 Pedestal (5100DR-095-01).</p> |
| Remote controlled movements (by an operator) | <ol style="list-style-type: none"> 1) X axes through traction motor on the Dolly 2) Z axes through a motor on the Lift 3) Pan & Tilt through the Head where the payload is mounted. | | <ol style="list-style-type: none"> 1) Z axes through a motor on the Lift 2) Pan & Tilt through the Head where the payload is mounted. |
| Manual controlled movements (by an operator) | None | | XY Axes |
| Differences | Floor-Mounted Rail motorized dolly | Ceiling-Mounted Rail motorized dolly | Non-motorized floor dolly |

| | Furio Floor-Mount Rail System | Furio SkyDolly Ceiling-Mounted Rail System | Furio BlackBird Elevation System |
|------------------------|--|--|----------------------------------|
| Product ratings | <p>Electrical Input rating: 12.5A, 100-240Vac, 50/60Hz</p> <p>Electrical Output rating (Power bar): 5A max, 100-240Vac, 50/60Hz</p> <p>Mechanical rating:</p> <ul style="list-style-type: none"> • X350: 5.3Kg Max Payload • VR600: 25Kg Max Payload <p>System Speed Rating:</p> <ul style="list-style-type: none"> • S2 Lift: 127mm/sec • SE Lift: 152mm/sec • X350 Pan & Tilt: 0.001 - 45 deg /sec. • VR600 Pan & Tilt: 0.001 -90 deg /sec. <p>Environmental ratings: 0°C to +40°C, 0% to 90% RH (non-condensing)</p> | | |
| Input Ports | <p>Dollies: 1x Main AC input, 1x Remote E-Stop</p> <p>X350 Head: 1x 48Vdc input power, 2x Ethernet Ports, 1x Sync In Port, 1x CAN Control Port</p> <p>VR600 Head: 1x 48Vdc input power, 1x Ethernet Ports, 1x Sync In Port, 2x CAN Control Port</p> | | |
| Output Ports | <p>Dollies: 5x AC Main power bar, 1x Can (wiredraw),</p> <p>X350 Head: 1x 12Vdc output, 1x Serial Port, , 1x Sync Out Port, 2x Lens control ports</p> <p>VR600 Head: 1x Serial Port, , 3x Lens/Cam control ports</p> | | |