

FURIO

Robotic Dolly Systems

Technical Manual

Thank You for Choosing Ross

You've made a great choice. We expect you will be very happy with your purchase of Ross Technology. Our mission is to:

1. Provide a Superior Customer Experience
 - offer the best product quality and support
2. Make Cool Practical Technology
 - develop great products that customers love

Ross has become well known for the Ross Video Code of Ethics. It guides our interactions and empowers our employees. I hope you enjoy reading it below.

If anything at all with your Ross experience does not live up to your expectations be sure to reach out to us at solutions@rossvideo.com.



David Ross
CEO, Ross Video
dross@rossvideo.com

Ross Video Code of Ethics

Any company is the sum total of the people that make things happen. At Ross, our employees are a special group. Our employees truly care about doing a great job and delivering a high quality customer experience every day. This code of ethics hangs on the wall of all Ross Video locations to guide our behavior:

1. We will always act in our customers' best interest.
2. We will do our best to understand our customers' requirements.
3. We will not ship crap.
4. We will be great to work with.
5. We will do something extra for our customers, as an apology, when something big goes wrong and it's our fault.
6. We will keep our promises.
7. We will treat the competition with respect.
8. We will cooperate with and help other friendly companies.
9. We will go above and beyond in times of crisis. *If there's no one to authorize the required action in times of company or customer crisis - do what you know in your heart is right. (You may rent helicopters if necessary.)*

Technical Manual for Furio Robotic Dolly Systems

- Ross Part Number: **5100DR-043-04**
- Release Date: May 20, 2025.

The information contained in this manual is subject to change without notice or obligation.

Copyright

© 2025 Ross Video Limited. Ross® and any related marks are trademarks or registered trademarks of Ross Video Limited. All other trademarks are the property of their respective companies. PATENTS ISSUED and PENDING. All rights reserved. No part of this publication may be reproduced, stored in a retrieval system, or transmitted in any form or by any means, mechanical, photocopying, recording, or otherwise, without the prior written permission of Ross Video. While every precaution has been taken in the preparation of this document, Ross Video assumes no responsibility for errors or omissions. Neither is any liability assumed for damages resulting from the use of the information contained herein.

Patents

Ross Video products are protected by patent numbers US 7,034,886; US 7,508,455; US 7,602,446; US 7,802,802 B2; US 7,834,886; US 7,914,332; US 8,307,284; US 8,407,374 B2; US 8,499,019 B2; US 8,519,949 B2; US 8,743,292 B2; GB 2,419,119 B; GB 2,447,380 B. Other patents may apply or be pending.

Company Address and Contact Information



Ross Video Limited

8 John Street
Iroquois, Ontario
Canada, K0E 1K0

Ross Video Incorporated

P.O. Box 880
Ogdensburg, New York
USA 13669-0880

General Business Office: (+1) 613 • 652 • 4886

Fax: (+1) 613 • 652 • 4425

Toll Free Technical Support: 1-844-652-0645 (North America)

+800 1005 0100 (International)

Technical Support: (+1) 613 • 652 • 4886

After Hours Emergency: (+1) 613 • 349 • 0006

E-mail (Technical Support): techsupport@rossvideo.com

E-mail (General Information): solutions@rossvideo.com

Website: <http://www.rossvideo.com>

Contents

Welcome	6
Text Formatting Conventions	6
Contacting Technical Support	6
Safety Instructions	8
Safe Handling Techniques	10
System Components	11
Product Packages	12
Furio SE Robotic Dolly	12
..... Perform firmware updates as needed via Ross Video customer service.	19
Furio Track	19
Anti-Tipping System Assembly Procedure	20
Furio VR600 Robotic Pan and Tilt Head	23
Furio SE Three-Stage Robotic Lift	24
Furio S2 Two-Stage Robotic Lift	25
SmartShell Control Application	26
Accessories	27
Maintenance	31
General Inspection and Cleaning	31
Disassembling the Dolly	32
Reassembling the Dolly	36
Replacing the Main FRU	39
Replacing the Drive Wheel Units	43
Replacing the Passive Wheel Units	43
Technical Specifications	44
Product Packages	45
Legacy Components and Accessories	50
Electrical and Environmental Specifications	51

Welcome

Welcome to the Technical Manual for Furio Dolly systems.

This manual provides a general overview of the system, technical specifications, basic maintenance procedures, and safety information.

For information about operating the system, see the *SmartShell User Guide (5100DR-002-xx)*.

Important: Before operating or servicing any Furio system, please refer to and carefully read the *Furio Safety Guide (5100DR-304-02)* to ensure safe handling and operation.

IMPORTANT: This manual provides general product information and describes how to perform selected maintenance tasks. It is not a comprehensive service manual and is not a replacement for product commissioning or formal training.

IMPORTANT: Initial setup and commissioning must be performed by Ross Video personnel only. Unauthorized attempts by customers or third parties to unpack, assemble, or commission any portion of the robotics system may result in equipment damage and/or serious injury. Any such attempts may void product warranties.

Text Formatting Conventions

Special text formats are used in this Technical Manual to identify parts of the user interface, text that a user must enter, or a sequence of menus and sub-menus that must be followed to reach a particular command.

Text Format	Meaning
Bold text	Bold text is used to identify a user interface element such as a dialog box, menu item, or button. For example: In the Presets panel, tap ADD .
Courier text	Courier text is used to identify text that a user must type. For example: In the address bar, type <code>localhost</code> and press Enter .
<i>Italic text</i>	Italic text is used to identify the titles of referenced guides, manuals, or documents. For example: For more information, refer to the <i>SmartShell User Guide (5100DR-002-xx)</i> .
>	Menu arrows are used in procedures to identify a sequence of menu items that you must follow. For example, if a step reads “ Display > Widgets ,” you would tap the Display menu and then tap Widgets .

Contacting Technical Support







At Ross Video, we take pride in the quality of our products, but if problems occur, help is as close as the nearest telephone.









Our 24-hour Hot Line service ensures you have access to technical expertise around the clock. After-sales service and technical support is provided directly by Ross Video personnel. During business hours (Eastern time), technical support personnel are available by telephone any time. After hours and on weekends, a direct emergency technical support phone line is available. If the technical support person who is on call does not answer this line immediately, a voice message can be left and the call will be returned shortly. This team of highly trained staff is available to react to any problem and to do whatever is necessary to ensure customer satisfaction.

- **Toll Free Technical Support:** 1-844-652-0645 (North America), or +800 1005 0100 (International)
- **Technical Support:** (+1) 613-652-4886
- **After Hours Emergency:** (+1) 613-349-0006
- **E-mail for Technical Support:** techsupport@rossvideo.com
- **E-mail for General Information:** solutions@rossvideo.com
- **Website:** <http://www.rossvideo.com>

Safety Instructions

The following table contains important safety instructions and notices. Before using this product and any associated equipment, read and keep these instructions and notices. Heed all warnings and follow all safety instructions.

 Caution	<p>This equipment must be operated by trained personnel only.</p> <p>This equipment must be operated in a controlled and restricted-access environment only.</p>
 Warning	<p>The safe operation of this product requires that a protective earth connection be provided. A grounding conductor in the equipment's supply cord provides this protective earth. To reduce the risk of electrical shock to the operator and service personnel, this ground conductor must be connected to an earthed ground.</p> <p>Use only power cords specified for this product and certified for the country of use.</p> <p>Do not defeat safety purpose of the grounding-type plug. A grounding type plug has two blades and a third grounding prong. The third prong is provided for your safety. If the provided plug does not fit in to your outlet, consult an electrician for replacement of the obsolete outlet.</p> <p>Protect power cord from being walked on or pinched, particularly at plugs, convenience receptacles, and points where they exit from the apparatus.</p>
 ESD	<p>ESD Susceptibility — This symbol on the equipment or within the equipment manual indicates that an electrical or electronic device or assembly is susceptible to damage from an ESD event.</p>
 Warning	<p>Hazardous Voltages — This symbol on the equipment or within the equipment manual indicates the presence of uninsulated “dangerous voltage” within the product enclosure that may be of sufficient magnitude to constitute a risk of shock to persons.</p>
 Warning	<p>Indoor Use: “WARNING – TO REDUCE THE RISK OF FIRE OR ELECTRIC SHOCK, DO NOT EXPOSE THIS APPARATUS TO RAIN OR MOISTURE”</p> <p>Do not use this apparatus near water.</p> <p>Do not block any ventilation openings. Install in accordance with manufacturer’s instructions.</p> <p>Do not install near heat sources such as radiators, heat registers, stoves, or other apparatus (including amplifiers) that produce heat.</p> <p>Only use attachments/accessories specified by the manufacturer.</p> <p>Unplug this apparatus during lightning storms or when unused for long periods of time.</p> <p>Clean only with a dry cloth.</p>
 Warning	<p>Refer all servicing to qualified personnel. Servicing is required when the apparatus has been damaged in any way, such as power-supply cord or plug damage, liquid has been spilled or objects have fallen into the apparatus, the apparatus has been exposed to rain or moisture, does not operate normally, or has been dropped.</p>
 Warning	<p>To reduce the risk of fire, replacement fuses must be the same type and rating.</p>

	Warning	This product contains safety critical parts, which if incorrectly replaced may present a risk of fire or electrical shock. Components contained within the product's power supplies and power supply area are not customer-serviceable and should be returned to the factory for repair.
	Caution	Ensure that proper cable management techniques are used at all times. Bundle and wrap cables neatly, and provide adequate strain relief and slack where necessary. Test your cable installation by slowly moving the robotic units through their entire range of motion and observing the cables, to ensure that they do not become taut, or snag on anything. Avoid running cables along floors in places where they may present a tripping hazard. Clearly mark areas where cables may present a tripping hazard, and keep personnel away from such areas. Inspect cables periodically for damage, and to ensure that proper cable management is maintained.
	Warning	Damaged or improper cables may cause electric shock and/or fire. Ensure that all cables and connectors are of suitable type for their purpose, and that all power cable conductors are of adequate gauge for the voltage and current required. Inspect all cables periodically to check for damage. If a cable becomes damaged, turn off power to the system immediately, and then replace the damaged cable.
	Warning	Serious injuries can result from people tripping over equipment, such as cables. Methods of reducing such risks include, but are not limited to, the following: <ul style="list-style-type: none"> • Erecting signs at studio entrances to remind people about tripping hazards and other studio hazards. • Training personnel about safety procedures and proper cable management techniques. • Showing personnel and guests the locations of cables equipment, and explaining that robotic cameras and cables attached to them may move at any time. • Escorting guests at all times while in the studio. • Ensuring adequate lighting when working in the studio. • Marking safe paths and/or restricted areas, to keep people away from moving robots and potential tripping hazards.
	Caution	Loose or overtightened bolts may cause equipment damage. When servicing, tighten bolts to specified torque.
	Warning	Moving parts may present a pinching hazard. Keep all personnel away from robots when they are operational. When a robotic head, dolly, or lift moves, fingers touching or near the unit or the payload may become pinched. When installing or adjusting the payload, ensure that power to the system is turned off.
	Warning	When servicing or moving equipment, always observe safe handling practices. Get help to move heavy items. Use safe lifting techniques. Follow all safety rules of your workplace.
	Caution	Loose payloads may slip, causing equipment damage and injury. Periodically check all bolts that fasten the payload, to ensure that they are tightened to specified torque. If the payload is loose or slips, ensure that it is properly balanced and fastened before operating the robot.
	Caution	Imbalanced payloads may cause equipment damage and may present a tipping hazard. Ensure payloads are properly balanced. If you adjust a payload, always rebalance it.

Safe Handling Techniques

When manually handling the Furio dolly, it's important to follow these guidelines to ensure operator safety and prevent equipment damage:

- **Use the Designated Handles**
Always push the dolly from the designated handles or lift points to avoid strain and prevent damage to sensitive components such as the lift column or robotic head.
- **Check the Track**
Ensure the track is free of obstacles and debris to maintain smooth movement. Clean and well-maintained tracks are essential for safe operation.
- **Maintain Control**
Maintain control of the dolly at all times, especially when navigating turns or tight spaces. Avoid sudden movements that could destabilize the dolly.
- **Work in Teams**
Always move the dolly with assistance. Having at least one other person help when navigating uneven or tight spaces will reduce the risk of tipping or equipment damage.
- **Pushing on Inclines**
Use extra caution when pushing the dolly on slopes or inclines. Ensure that the dolly is fully under control to prevent runaway movement.
- **Balance the Load**
Ensure the dolly's payload is properly balanced before pushing. An imbalanced payload increases the risk of tipping or excessive strain on one side of the dolly. Regularly check the balance and adjust as necessary.
- **Floor and Track Conditions**
Keep the floor and track clear of debris to prevent the dolly from snagging or jamming during movement. Check that all wheels are properly seated on the track.

System Components

Furio track-based studio dolly systems are used in top productions around the world to deliver dramatic and compelling moving shots, while also providing industry-leading accuracy and repeatability for automated and/or virtual productions.

Furio Dolly systems are designed to be modular. Each dolly system includes a Furio SE robotic dolly and one VR600 or X350 robotic pan & tilt heads. The system may also include one of two robotic elevation columns (three-stage SE lift or two-stage S2 lift). Depending on the studio layout, a single track may accommodate up to four dollies.

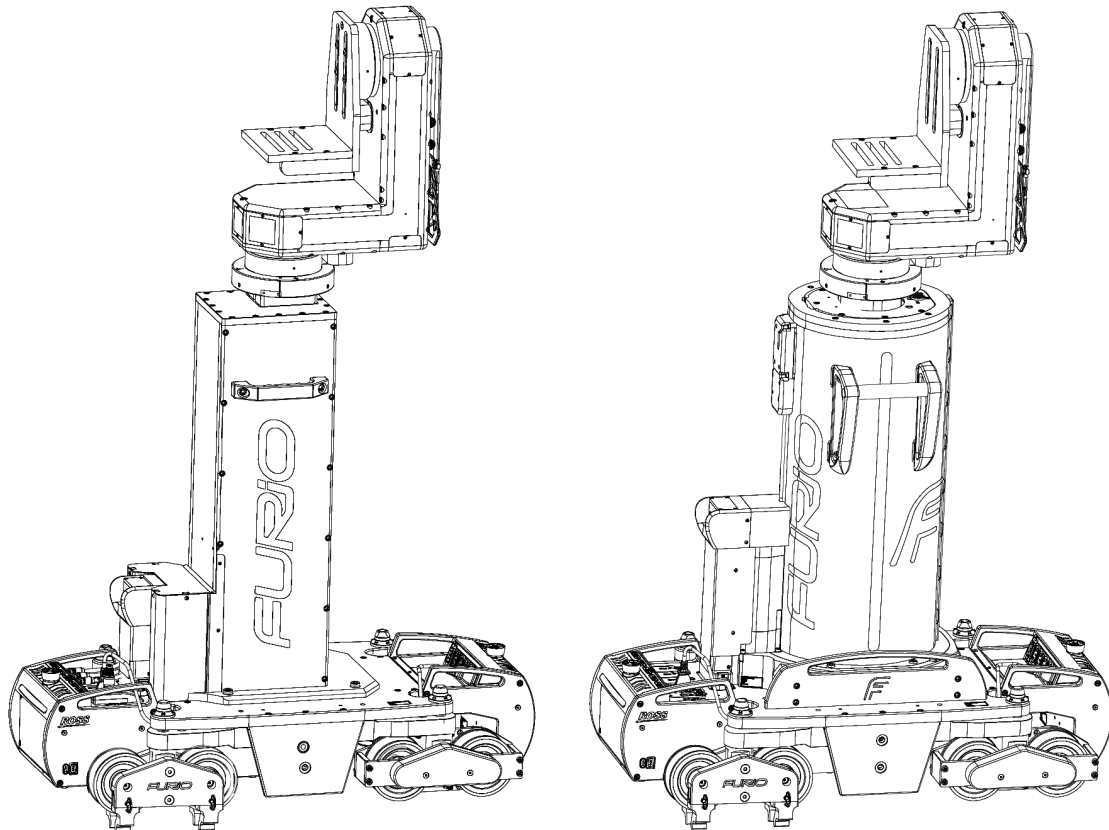

Figure 1 Furio SE Dolly with S2 Lift (left) and SE Lift (right), each with the VR600 Head

This section provides information about components of Furio Dolly systems, and includes the following topics:

- **“Product Packages”**
- **“Furio SE Robotic Dolly”**
- **“Barcode Positioning System (BPS)”**
- **“Furio Track”**
- **“Furio VR600 Robotic Pan and Tilt Head”**
- **“Furio SE Three-Stage Robotic Lift”**
- **“Furio S2 Two-Stage Robotic Lift”**
- **“SmartShell Control Application”**
- **“Accessories”**

Product Packages

Each Furio Dolly system consists of a floor-mounted track, a Furio SE robotic dolly, and a Furio robotic pan & tilt head. The system may also include a robotic lift or a fixed-height column (optional accessory).

Track layouts are custom-designed for each installation. Track and BPS components are sold separately from the Furio Dolly packages.

The Furio Dolly packages are as follows:

- **FRO-X350-ST-DLY-SE** — Furio X350 pan and tilt head mounted on a Furio SE robotic dolly. The head mounts to the dolly via a mounting adapter (included), or via a fixed-height column (optional accessory).
- **FRO-X350-ST-FULL-SE** — Furio X350 pan/tilt head atop a Furio SE three-stage robotic lift, all mounted on a Furio SE robotic dolly.
- **FRO-X350-ST-FULL-S2** — Furio X350 pan/tilt head atop a S2 two-stage robotic lift, all mounted on a Furio SE robotic dolly.
- **FRO-VR600-ST-DLY-SE** — Furio VR600 pan and tilt head mounted on a Furio SE robotic dolly. The head mounts to the dolly via a mounting adapter (included), or via a fixed-height column (optional accessory).
- **FRO-VR600-ST-FULL-SE** — Furio VR600 pan/tilt head atop a Furio SE three-stage robotic lift, all mounted on a Furio SE robotic dolly.
- **FRO-VR600-ST-FULL-S2** — Furio VR600 pan/tilt head atop a S2 two-stage robotic lift, all mounted on a Furio SE robotic dolly.

For more information about each product package, see “**Technical Specifications**”.

Furio SE Robotic Dolly

Packed with clever design ideas, the Furio SE Dolly combines smooth, precise movement with rugged reliability.

Dual-switched DC power supplies automatically detect and switch between 110V and 220V, offering global compatibility without reconfiguration.

An internal DC power converter for the pan & tilt head eliminates the need for an external power brick. The integrated power bar provides mains power for cameras, prompters, monitors, clocks, and more. All electrical connections feature self-recovering over-current detection to protect electrical circuits, and a complete array of status LEDs accelerate fault detection and diagnosis.

Safety is designed into all aspects of the Furio SE Dolly:

- E-Stop buttons on each end of the dolly immediately command the dolly, lift, and head to stop, ensuring maximum safety. When an E-stop is activated, the lift stays in its current position, the head becomes free-wheeling, and the dolly comes to a rapid controlled stop thanks to its constant current regenerative braking technology.

An optional remote E-Stop button is also available. For more information, see “**Remote Emergency Stop Module**”.

- The Furio SE Dolly has enhanced anti-tip stability arms that hug the track if the dolly starts to lean due to excessive speed in a turn. These silent wheel units prevent the dolly from tipping without introducing additional rolling resistance or noise during normal operation.
- Gently flashing front and rear light bars provide a visible indication that system is in motion.

- On-board optical sensor arrays detect warning reflectors to prevent the dolly from reaching the end of the track, in case track limits are not properly set in the control application.

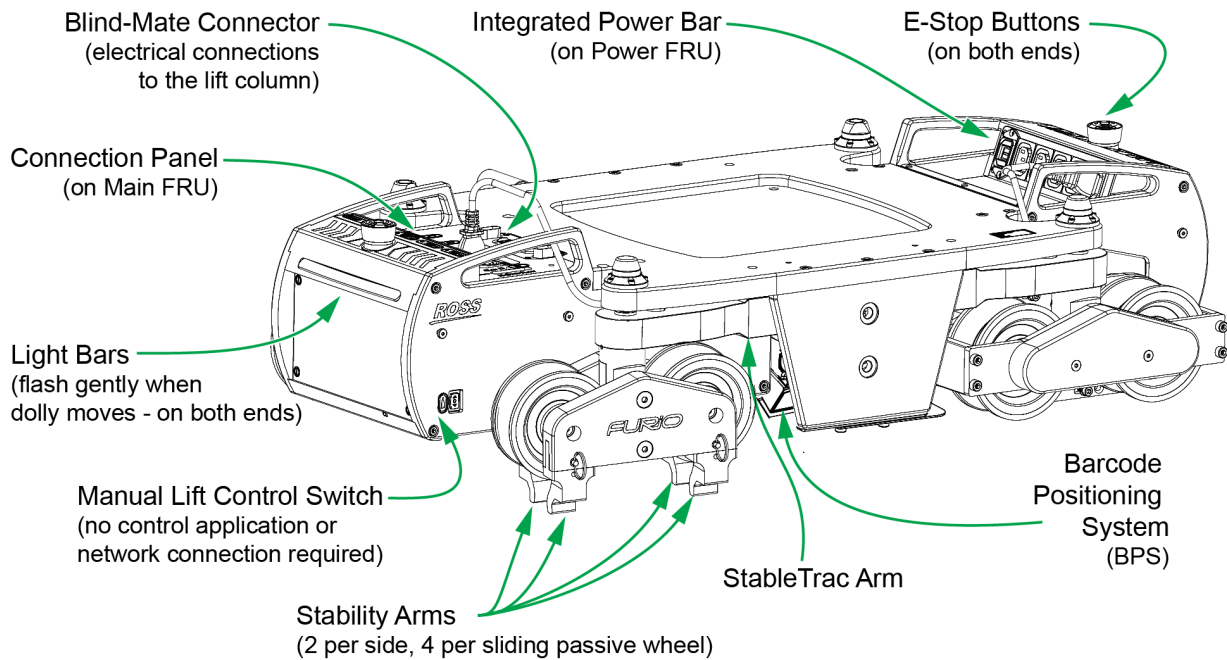

Figure 2 - Furio SE Dolly components

Field Replaceable Units (FRUs)

All electrical circuits are contained in two Field Replaceable Units (FRUs), featuring blind mate connections. Either FRU can be quickly replaced with the removal of just four screws.

The **Power FRU** receives power from the mains, and includes an integrated power bar for all accessories such as cameras, prompters, monitors, and clocks.

The **Main FRU** contains all the control electronics. All network and power connections for the dolly, lift, and head are through the Main FRU's connection panel (**Figure 3**).

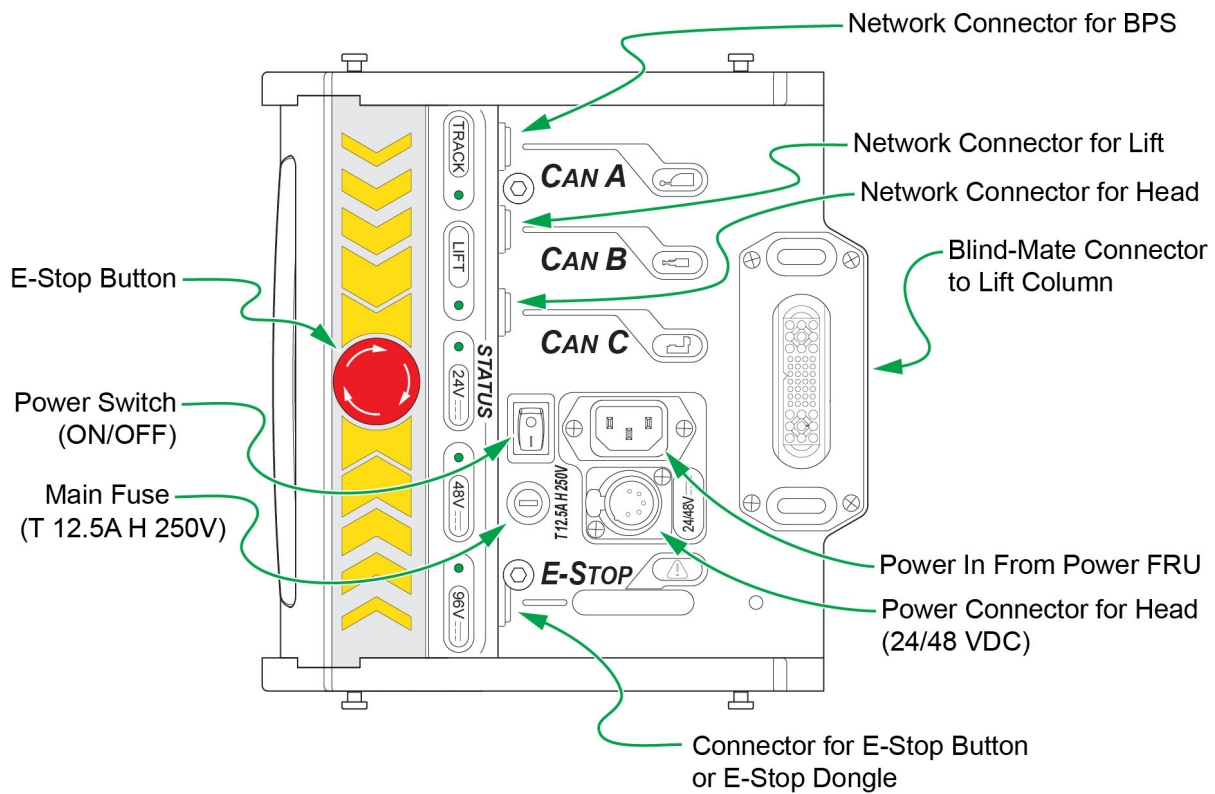

Figure 3 - Furio SE Dolly Main FRU Connection Panel

Figure 4 shows the Blind-Mate Connector to the Track Motor, which is not visible in (**Figure 3**).

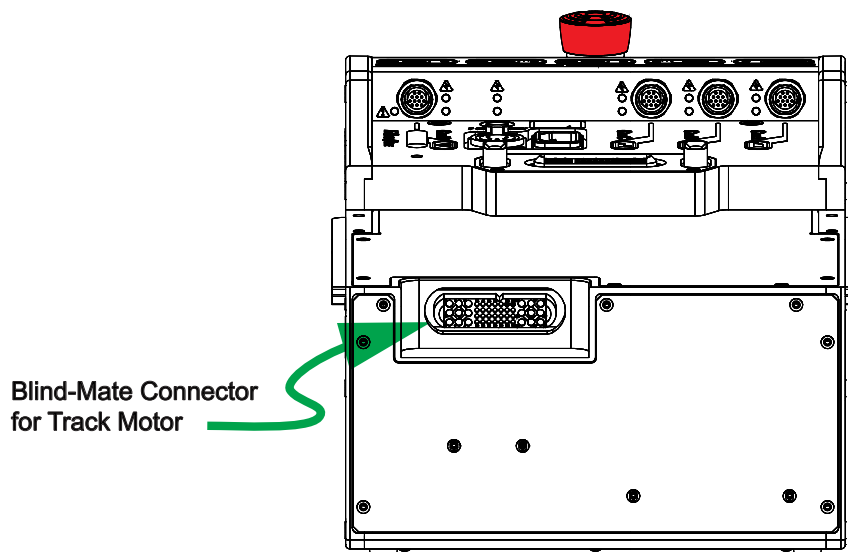

Figure 4 - Furio SE Dolly Blind Mate Connection to Track Motor

Figure 5 shows CAN and E-STOP connectors, and LEDs that are not visible in (**Figure 3**).

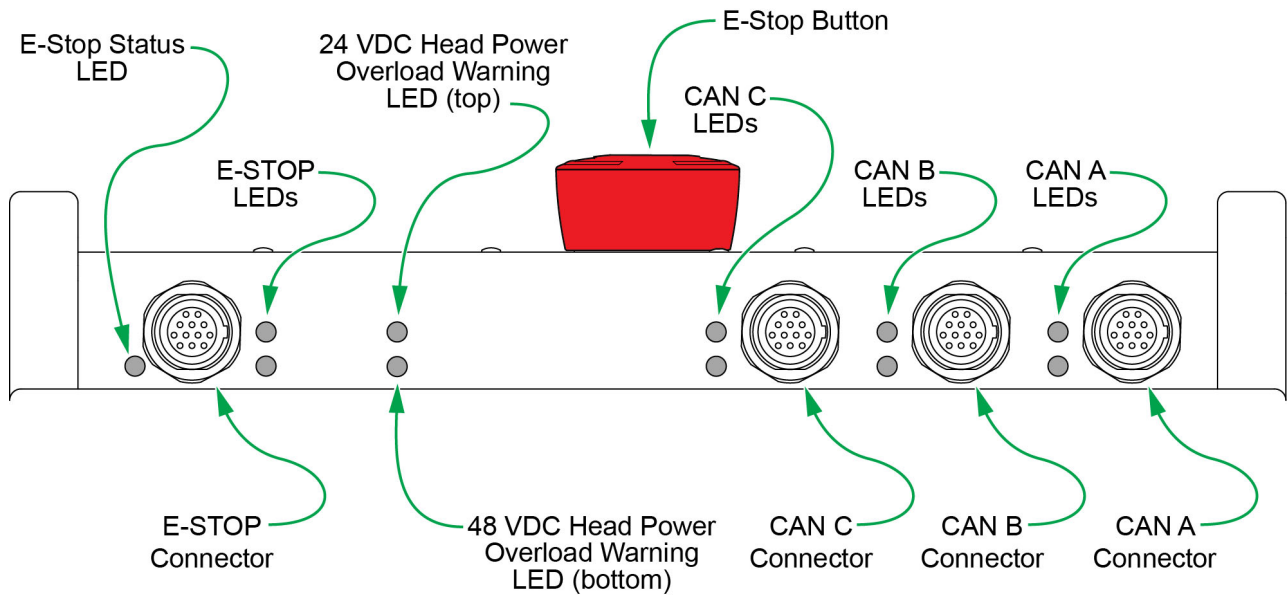

Figure 5 - CAN connectors and LEDs on the Main FRU Connection Panel

The following table describes LEDs on the Main FRU connection panel (**Figure 3** and **Figure 5**).

LED	Description / Meaning
TRACK	Track axis status: <ul style="list-style-type: none"> • green: operational • red: disabled or faulty See also Note 1 , after this table.
LIFT	Lift axis status: <ul style="list-style-type: none"> • green: operational • red: disabled or faulty See also Note 1 , after this table.
24 V	24 VDC power supply status: <ul style="list-style-type: none"> • green: good • off: undervoltage or no power
48 V	48 VDC power supply status: <ul style="list-style-type: none"> • green: good • off: undervoltage or no power
96 V	96 VDC power supply status: <ul style="list-style-type: none"> • green: good • off: undervoltage or no power
CAN A — 24 VDC overload warning (top LED beside CAN A connector)	24 VDC overload warning for BPS CAN connection: <ul style="list-style-type: none"> • off: no overload • red: overload or short-circuit
CAN A — 48 VDC overload warning (bottom LED beside CAN A connector)	Not used. Reserved for future use.

LED	Description / Meaning
CAN B — 24 VDC overload warning (top LED beside CAN B connector)	24 VDC overload warning for lift encoder CAN connection: <ul style="list-style-type: none"> • off: no overload • red: overload or short-circuit
CAN B — 48 VDC overload warning (bottom LED beside CAN B connector)	Not used. Reserved for future use.
CAN C — 24 VDC overload warning (top LED beside CAN C connector)	24 VDC overload warning for robotic head: CAN connection: <ul style="list-style-type: none"> • off: no overload • red: overload or short-circuit
CAN C — 48 VDC overload warning (bottom LED beside CAN C connector)	Not used in Furio SE studio systems. Reserved for use in Furio SE remote (SE Live) systems.
24 VDC head power overload warning (top LED adjacent to the main fuse)	Overload warning for VR100 head: <ul style="list-style-type: none"> • off: no overload • red: overload or short-circuit See also Note 2 , after this table.
48 VDC head power overload warning (bottom LED adjacent to the main fuse)	Overload warning for VR600 head: <ul style="list-style-type: none"> • off: no overload • red: overload or short-circuit See also Note 2 , after this table.
E-STOP — 24 VDC overload warning (top LED right of E-STOP CAN connector)	24 VDC overload warning for E-STOP box/dongle CAN connection: <ul style="list-style-type: none"> • off: no overload • red: overload or short-circuit
E-STOP — 48 VDC overload warning (bottom LED right of E-STOP CAN connector)	Not used. Reserved for future use.
E-STOP status warning (left of the E-STOP CAN connector)	Operations status for E-STOP safety: <ul style="list-style-type: none"> • off: operational • red: E-STOP activated, and must be reset before operation can resume. Note: If there is no E-STOP box, an E-STOP dongle must be inserted for normal operation.

Additional notes about LEDs described in the preceding table:

1. The **TRACK** axis and **LIFT** axis status LEDs turn red under any of the following conditions:
 - Amplifier fault
 - Amplifier over temperature
 - Motor phasing error
 - Motor over temperature
 - Under voltage
 - Over voltage

- Short circuit
 - Phase not initialized
 - Command input fault
2. The power connector for the head (24 VDC / 48 VDC) is protected against overcurrent by resettable fuses. Each of the associated LEDs (adjacent to the main fuse) turns red when its fuse trips (top LED for 24 VDC VR100 supply, bottom LED for 48 VDC VR600 supply).

When the faulty cable or device is unplugged, the associated LED turns off but the fuse may take up to one minute to cool completely and reset.

Barcode Positioning System (BPS)

The Barcode Positioning System (BPS) replaces traditional wiredraw encoders in all Furio models effective July 2024. This transition enhances the precision, reliability, and maintenance of the system.

Operating BPS on a Furio Dolly System requires **SmartShell v7.0b** or higher with template files properly configured.

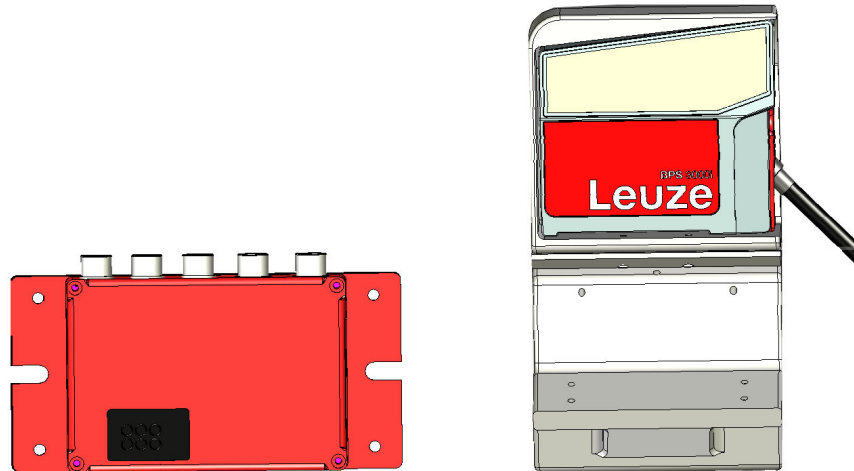

Figure 6 Gateway, BPS Unit, BPS Bracket, and CAN Cable (not all kit components shown)

For BPS upgrade installation instructions, refer to the **BPS Upgrade Guide (5100DR-383-02)**.

Key Specifications

- **Accuracy:** Submillimeter positioning accuracy from 0 to 10,000 meters.
- **Speed:** Control at traverse rates up to 5 millimeters per second.
- **Measurement:** Simultaneous position and speed measurement.

Environmental Requirements

- **Operating Temperature:** -35°C to 50°C (with heating).
- **Humidity:** 0% to 90% relative humidity, non-condensing.
- **Lighting:** Avoid direct exposure to intense, direct lighting; ensure consistent lighting conditions.
- **Cleanliness:** Maintain a clean environment; regular cleaning of barcode tape and sensors with a soft cloth and commercial glass cleaner.

Installation and Mounting

When mounting the BPS unit and installing barcode tape:

- Ensure barcode tape is free of wrinkles and mechanical tension.
- Barcode tapes are available in the following lengths:
 - › 10 meters (Product Code FRO-BPS-TAPE-10)
 - › 20 meters (Product Code FRO-BPS-TAPE-20)
 - › 30 meters (Product Code FRO-BPS-TAPE-30)
 - › 40 meters (Product Code FRO-BPS-TAPE-40)
 - › 50 meters (Product Code FRO-BPS-TAPE-50)
 - › 70 meters (Product Code FRO-BPS-TAPE-70)

Maintenance

Routine checks include:

- Regularly inspect barcode tape for wear or damage.
- Clean optical sensors and barcode tape to ensure accurate readings.

Perform firmware updates as needed via Ross Video customer service.

Furio Track

The Furio SE dolly rides on a track made up of straight and/or curved sections. Ross Video can produce straight tracks in a variety of lengths, and curved tracks of various radii. Tracks are black by default, but can be manufactured in any RAL-standard color.

Track layouts are custom-designed for each installation. Track sections are sold separately from the Furio Dolly packages.

For added safety, spring-loaded bumpers are installed at both ends of the track. Ideally the bumpers never come into contact with a dolly because there are two other methods of limiting dolly range. Track limits are set in the control application. As a backup safety precaution, reflectors placed between the rails are detected by optical sensor arrays on the dolly, which then stops rapidly.

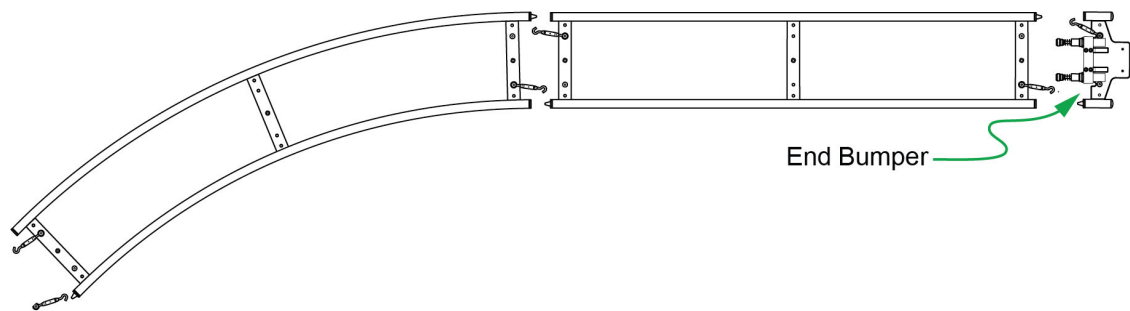

Figure 7 - Furio Dolly Track, showing Curved and Straight Track, with Bumpers

Up to four dollies can occupy a single track.

The BPS enables the system to determine the exact track position of the dolly at all times, which is essential for VS/AR applications.

If there are multiple dollies on the track (4 maximum), we highly recommend installing a Furio Collision Avoidance System. This system enables dollies to exchange position data so they can avoid colliding. For more information, see "**Furio Collision Avoidance System**".

Anti-Tipping System Assembly Procedure

The Furio dolly's anti-tipping system must be installed according to the track type used in your system. This section outlines the assembly steps and safety measures required to install the anti-tipping features effectively.

Anti-Tipping Safety Features

The Furio dolly is equipped with several anti-tipping mechanisms to ensure safe operation:

- **Stability Arms**

Used for curved and straight tracks.

Stability arms are included with every Furio dolly and are designed for use on standard tracks. The dolly includes enhanced stability arms, located on the sliding passive wheels, are installed after the dolly is placed on the track and are designed to grip the rail, preventing the dolly from tipping during movement, especially at higher speeds or in turns. Refer to **Figure 11** below.

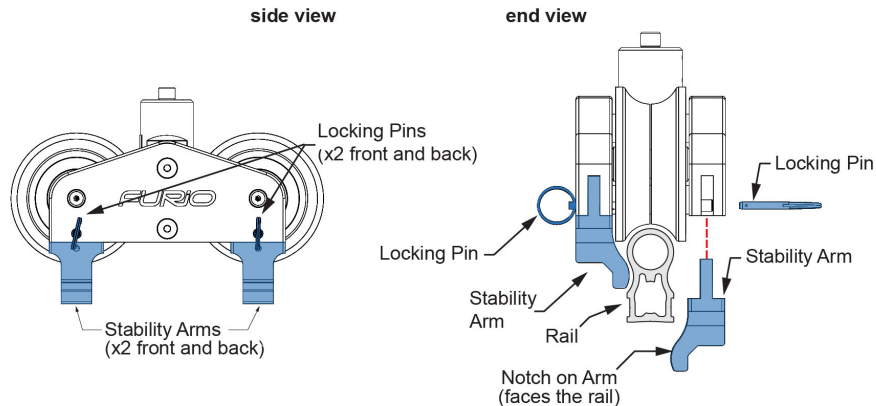

Figure 8 - Stability Arms

These arms provide extra stability in turns or when the dolly starts to lean due to excessive speed. It's essential to ensure that the stability wheels are properly attached and functioning after any maintenance or servicing.

Note: Stability arms have replaced the older stability wheels, which were previously used in older legacy Furio systems.

IMPORTANT: Stability arms cannot be used with flush-mounted rails due to clearance requirements with the floor. They are a standalone solution and are not used in conjunction with stability bars.

- **Stability Bars**

Used for integrated rails.

Stability bars are used in installations where a flush-mounted sub-floor. Stability bars replace the stability arms for these track types.

These extended stability bars are longer than the mid-mount bars, providing additional coverage to prevent tipping in any direction (forward, rearward, or lateral).

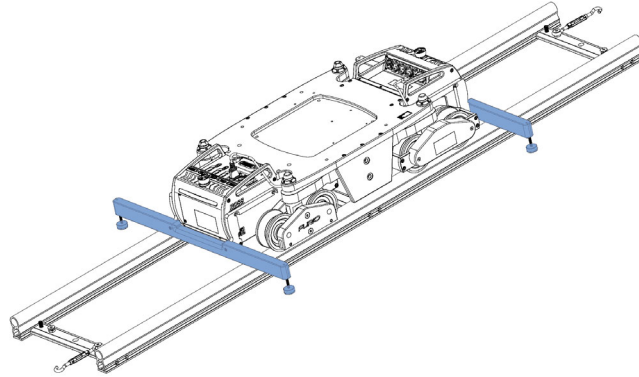

Figure 9 - Stability Bars (Integrated Rails Only)

- **Balanced Payload**

To maintain system stability, always ensure that the payload is balanced both vertically and horizontally. An imbalanced payload may lead to tipping hazards and negatively affect the smooth operation of the dolly. Regularly inspect the balance and adjust as needed before operating the system.

- **Clean and Well-Maintained Tracks**

Maintaining clean tracks is crucial for smooth dolly movement and preventing wobbling or instability. Periodically clean the dolly wheels using a dry foam brush and the tracks with a water-dampened cloth to remove dirt and debris

Caution: Do not operate the Furio system without the anti-tipping safety features described in this manual.

Anti-Tipping Components Maintenance Instructions

Position the dolly on the track and verify that the stability wheel or arms are properly seated on both the straight and curved sections.

Check that all bolts, screws and fasteners are tightened to the recommended torque settings.

Furio VR600 Robotic Pan and Tilt Head

The VR600 robotic pan and tilt head accepts a net payload of up to 66 lbs (30 kg). The pan and tilt motors have high-resolution encoders, making the VR600 ideal for Virtual Set and Augmented Reality (VS/AR) applications.

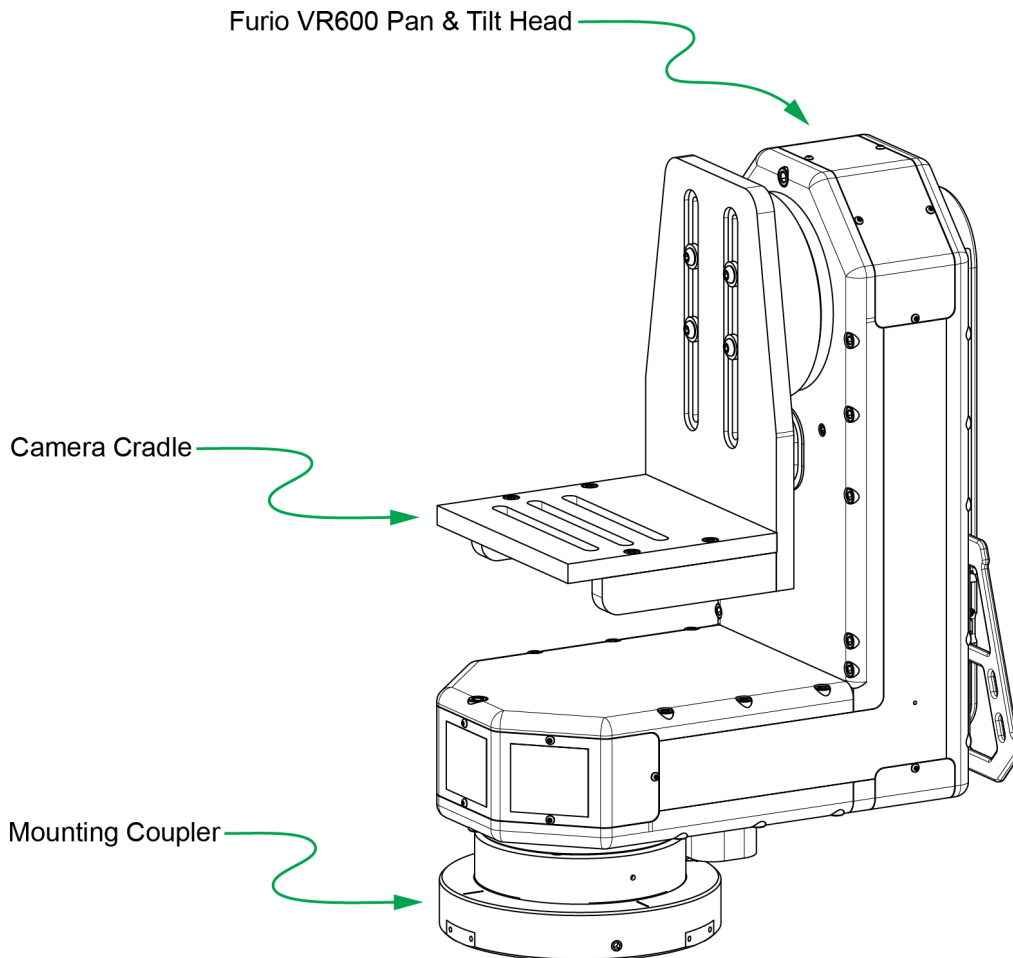

Figure 10 - Furio VR600 Robotic Head

Figure 12 shows the Furio VR600 connection panel.

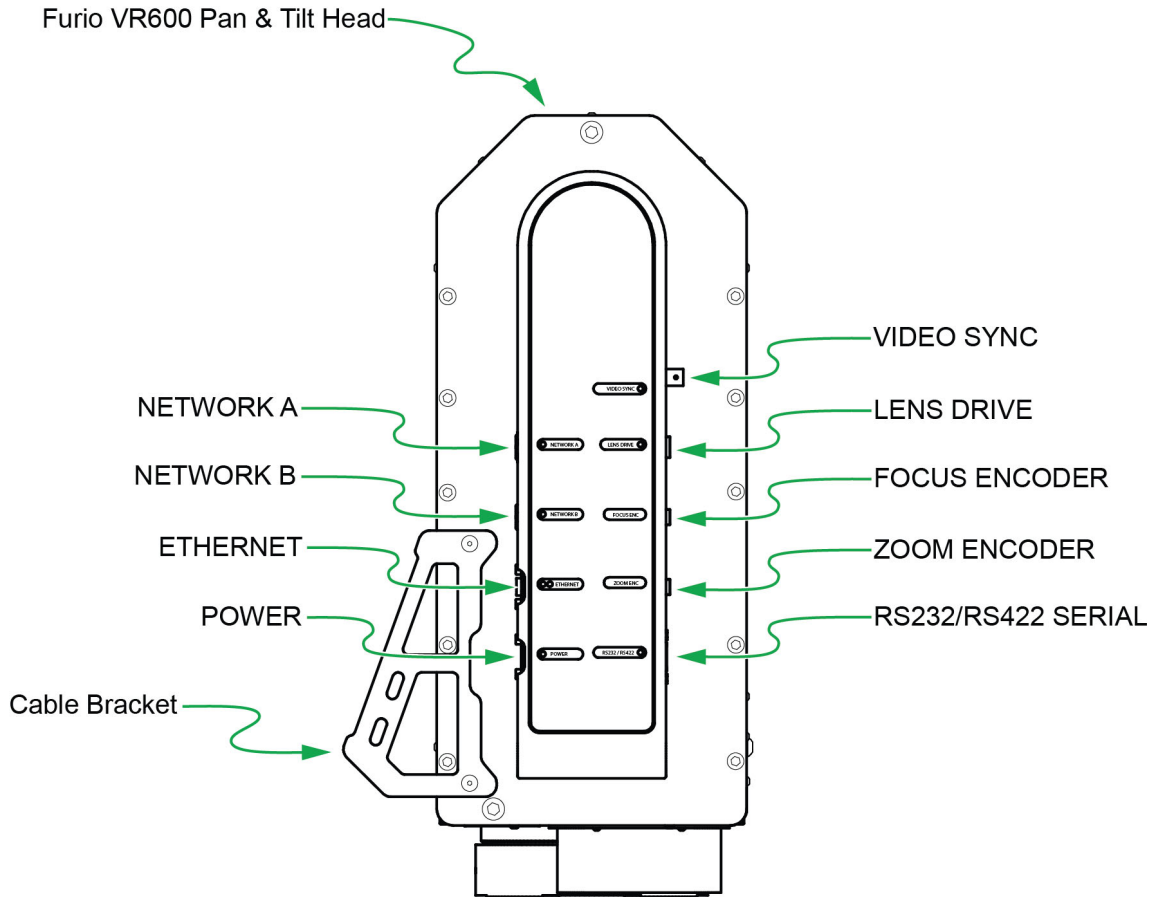

Figure 11 - Furio VR600 Pan & Tilt Head - Connection Panel

Furio SE Three-Stage Robotic Lift

The Furio SE three-stage robotic lift has an impressive vertical range of 865 mm (34.1"), allowing for a maximum height of 2228 mm (87.7") to optical center when mounted on a Furio SE dolly and using VR600 head, or 2024 mm (79.7") with an X350 head.

The sleek carbon-fiber body of the Furio SE lift has been carefully sculpted to ensure that cables never snag as the head or lift are repositioned. Internal linear guides maintain superior column alignment over the life of the system, with zero maintenance required.

Integrated cable management features permit cables to be neatly and safely secured to the lift, and a blind-mate electrical connection between the lift and the dolly further reduces cable clutter.

A failsafe brake mechanism keeps the lift in position during power loss (or when an e-Stop is triggered), ensuring the camera does not drop if on-air.

The Main FRU on the dolly is equipped with a manual lift control switch (**Figure 2** on **page 13**) that enables you to raise or lower the lift locally without a network connection or control system (the network connector for the head, CAN B, must be disconnected). The manual lift control switch enables you to lower the lift to its absolute bottom position so you can engage the lift lock for shipping or storage.

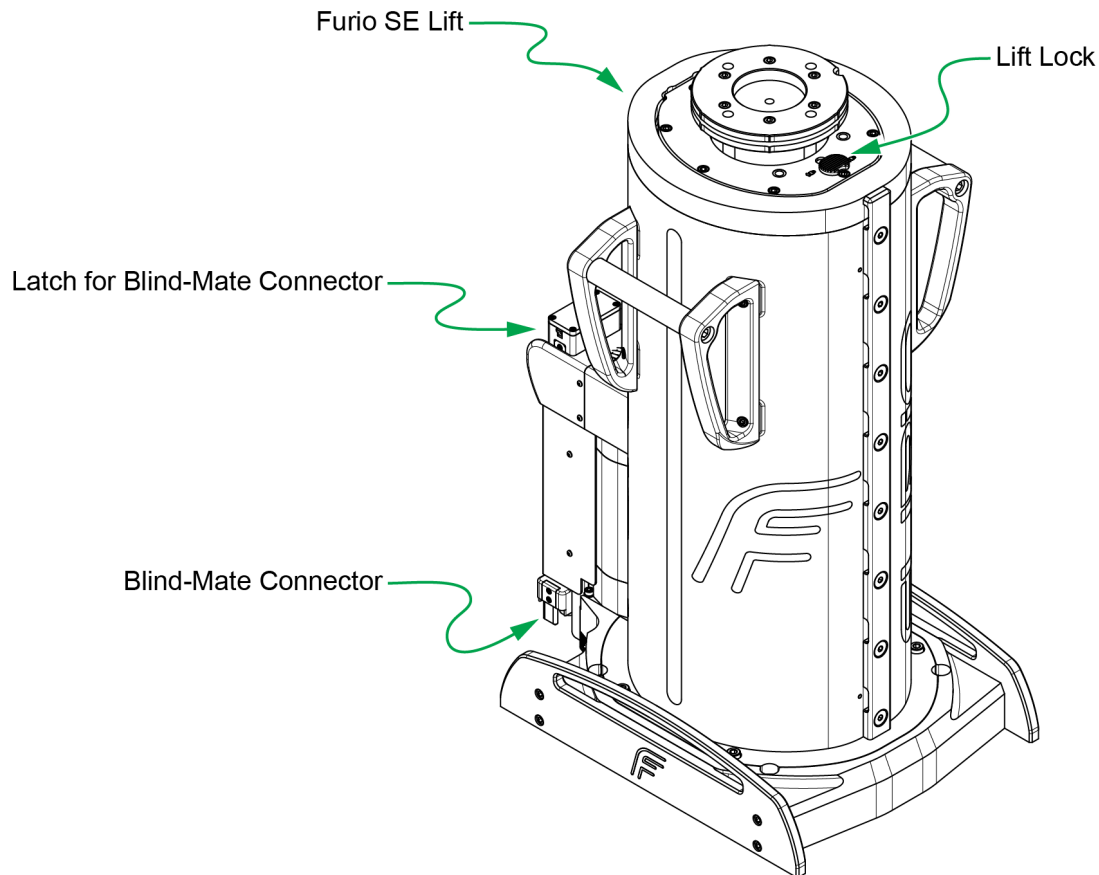

Figure 12 - Furio SE Lift (fully retracted)

Furio S2 Two-Stage Robotic Lift

The Furio S2 two-stage robotic lift achieves a vertical range of 483 mm (19.0"). When mounted on a Furio SE dolly, the Furio S2 lift has a maximum height of 1808mm (71.2") to optical center with a Furio VR600 head, or 1619 mm (63.7") with an X350 head.

The Furio S2 lift is based on the same core technologies used in the Furio SE lift, but with a simpler, more cost-effective design. This enables a more affordable option for applications where the higher performance Furio SE lift is not required, or where budgets are more constrained.

- Two-stage design uses the same linear guide technology and non-pneumatic design as the Furio SE lift for superior linearity with high reliability and zero maintenance
- Slip-free drive train eliminates need for external encoders while still providing accurate, repeatable positioning, and delivering reliable tracking data for virtual and augmented reality

The Main FRU on the dolly is equipped with a manual lift control switch (**Figure 2** on **page 13**) that enables you to raise or lower the lift locally without a network connection or control system (the network connector for the head, CAN B, must be disconnected). The manual lift control switch enables you to lower the lift to its absolute bottom position. This can help provide a better working height for servicing the robotic head, or make the overall size of the lift smaller to facilitate shipping.

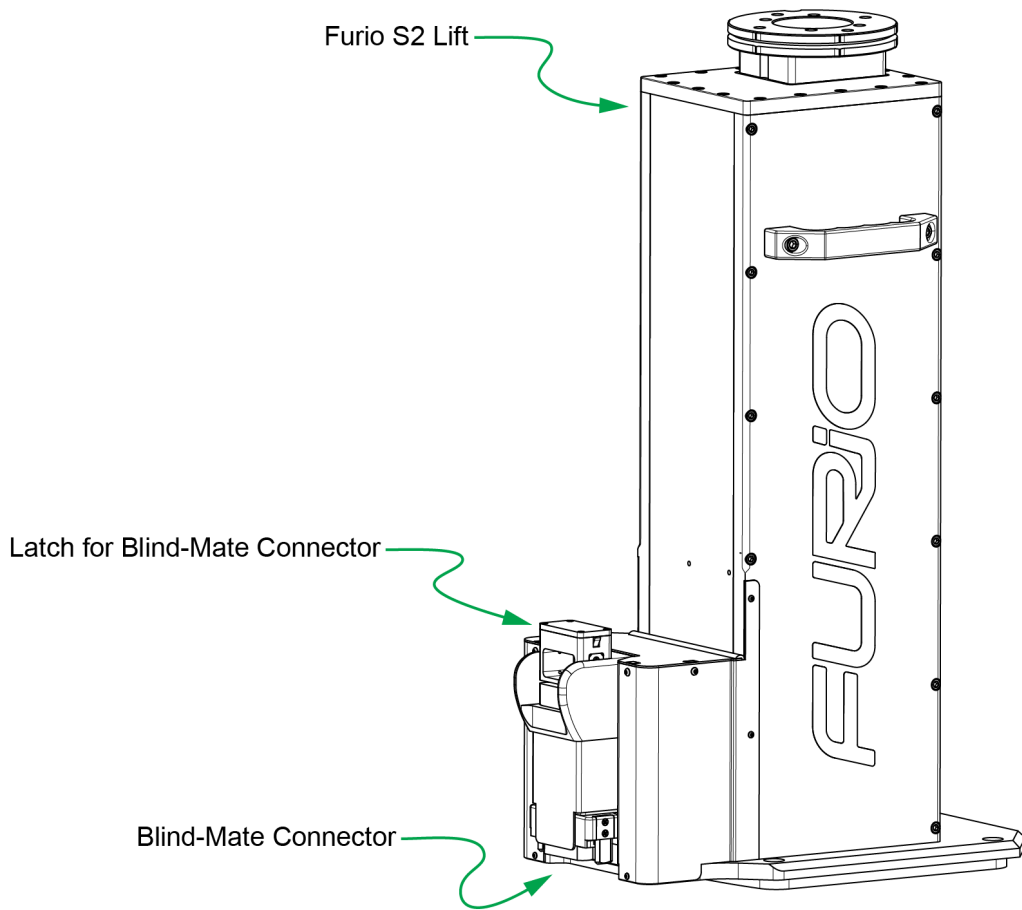

Figure 13 - Furio S2 Lift (fully retracted)

SmartShell Control Application

Furio robots use an open API that allows them to be controlled via a variety of technologies, including Ross Video's SmartShell control application and joystick panel, production switchers such as Ross Video Carbonite, and broadcast automation systems such as Ross Video OverDrive.

The main interface for controlling Ross Video CamBot and Furio robots is SmartShell, an easy-to-use touch-screen application that enables you to control camera systems automatically using stored presets, and manually using a joystick panel and/or buttons in the user interface.

The SmartShell computer comes with a touch screen monitor. You can also use the provided mouse and keyboard.

For detailed information about SmartShell, see the ***SmartShell User Guide (5100DR-002-xx)***.



Figure 14 - The SmartShell Control Application (in Matrix Mode), Controlling CamBot and Furio Robots

Ross Video Joystick Panel

You can control Furio camera systems manually using the joystick panel (see **Figure 16**). The joystick panel enables you to move multiple axes of a camera system simultaneously, for smooth camera operation.

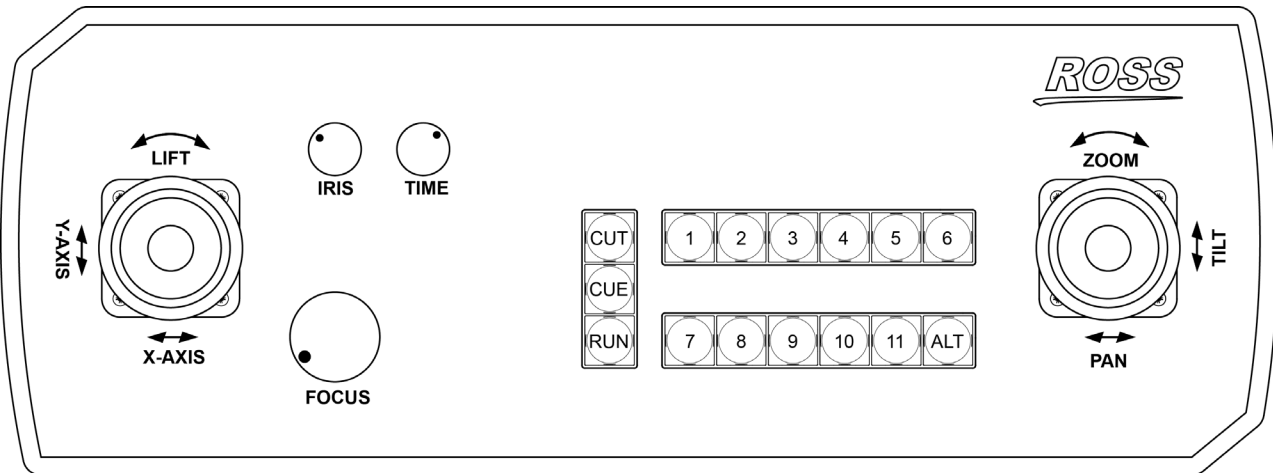

Figure 15 - Joystick Panel (may not appear exactly as shown)

During a show, operators typically use the joystick panel in conjunction with the matrix view in SmartShell. Alternatively, you can use the **Axis Control** panel in SmartShell to control camera systems manually. For more information, see the **SmartShell User Guide (5100DR-002-xx)**.

Accessories

This section describes optional accessories available for your Furio system:

- "Furio Collision Avoidance System"
- "Remote Emergency Stop Module"

- “Track Limit Reflector Brackets”
- “Fixed-Height Columns”
- “Furio Cable Guard”
- “CueScript Prompters”

Furio Collision Avoidance System

Ethernet-based Collision Avoidance — Starting with **SmartShell 7.0a**, the legacy Collision Avoidance System has been replaced by an Ethernet-based Collision Avoidance feature, which is now included by default.

Unlike the Controller Area Network (CAN) based Collision Avoidance, the Ethernet-based system requires no hardware accessories or extra cables, and there are no restrictions on the number of dollies on a track or track length.

The Ethernet-based system allows robotic dollies to exchange positional data and automatically manage their movement to prevent collisions. For more information on setting up and utilizing the Ethernet-based Collision Avoidance, consult with our Program Managers and see the latest ***Furio Collision Avoidance Setup Guide (5100DR-012)***.

Collision Avoidance System (Legacy) — The Collision Avoidance System, now considered a legacy accessory as of SmartShell 7.0a, enabled up to four Furio SE robotic dollies to operate on a single track without risk of colliding.

To protect two dollies, one FRO-CA kit was required. For three dollies, two FRO-CA kits were required. For four dollies, three FRO-CA kits were required. No more than four dollies could occupy a single track.

Each kit included one collision avoidance module and associated cables. The system allowed the robotic dollies to exchange positional data. If necessary, the dollies automatically limited their movement to prevent collisions.

Collision avoidance required additional cabling and conformance to specific track layout requirements. For more information about designing your layout to include collision avoidance, consult with our Program Managers and see the ***Furio Collision Avoidance Setup Guide (5100DR-012)***.

Remote Emergency Stop Module

An optional accessory for Furio Dolly systems, the remote emergency stop module (**FRO-ESTP-REM**) enables an operator to remotely stop the robot to which the module is connected. Each module comes with a 20 m (65.6') cable that connects the module to a single dolly or pedestal. Other available cable lengths include 30 m (98.4'), 40 m (131.2'), and 50 m (164').

Track Limit Reflector Brackets

Track limit reflectors act as a backup safety measure to help prevent the Furio SE Dolly from hitting the safety bumpers at the end of the track.

Each end of the Furio SE Dolly has on-board optical sensor arrays to detect reflectors and prevent the dolly from reaching the end of the track, in case track limits are not properly set in the control application.

Each Furio Dolly system comes with two loose reflectors that can be taped or screwed down to the studio floor.

As an optional accessory, Ross Video offers repositionable track limit reflector brackets (**FRO-RFLT-BRK**), which are easily installed between the rails of the track with no tools required. Each bracket includes a built-in reflector (**Figure 17**).

Install one reflector near each end of the track, allowing for ample stopping distance between the reflector and the safety bumpers. Be sure to position the each reflector such that its reflective surface is aligned with the optical sensor array on the near end of the closest dolly.

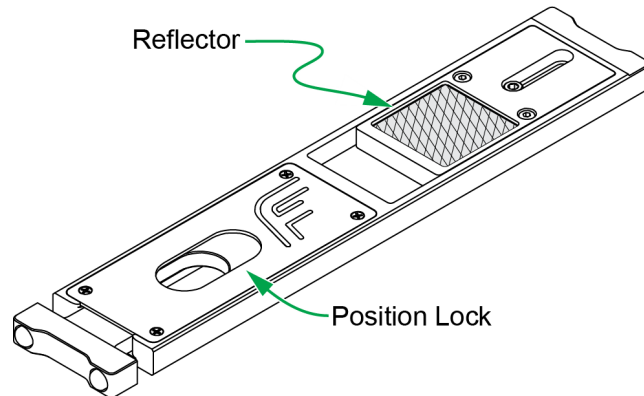

Figure 16 - Furio Track Limit Reflector Bracket (FRO-RFLT-BRK)

Fixed-Height Columns

Furio SE Fixed-Height Columns (**Figure 18**) provide elevation between the dolly and the robotic head.

Available heights are as follows:

- 30 cm (12") — FRO-FCO-12-SE
- 76 cm (30") — FRO-FCO-30-SE
- 122 cm (48") — FRO-FCO-48-SE

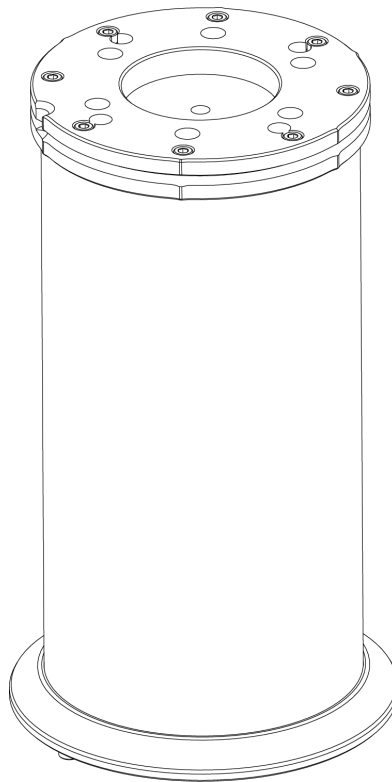

Figure 17 - 30 cm (12") Fixed-Height Column (FRO-FCO-12-SE)

Furio Cable Guard

Each Furio SE dolly has a bundle of cables that runs alongside the track as the dolly rolls from one end to the other. The cable bundle includes power and data cables for the dolly, camera, and accessories.

The Furio Cable Guard (**Figure 19**) is a barrier that keeps cable bundles off the track. For curved tracks, it runs along the outside edge of the curve. For best results, we recommend installing cable guard along the full length of track.

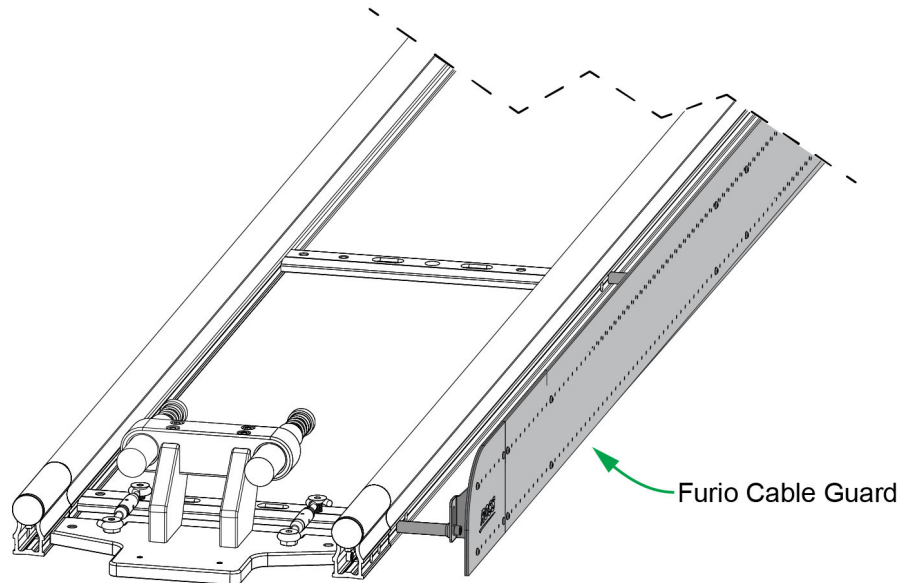

Figure 18 - Furio Cable Guard

CueScript Prompters

Ross Video sells CueScript™ teleprompters that are fully compatible with our robotic heads. Contact us for more information.

StableTrac Arm

Furio dollies include a Ross Video StableTrac™ arm which enhances stability during movement. For previous dolly models, the StableTrac Retrofit Kit **#FRO-DLY-ST-UPG** is available for purchase.

Maintenance

This section describes basic maintenance procedures for Furio Dolly systems. Read each procedure carefully and be certain you understand the steps before you perform them. Please contact Ross Video Technical Support if you have any questions or problems.

IMPORTANT: This manual provides general product information and describes how to perform selected maintenance tasks. It is not a comprehensive service manual and is not a replacement for product commissioning or formal training.

IMPORTANT: Initial setup and commissioning must be performed by Ross Video personnel only. Unauthorized attempts by customers or third parties to unpack, assemble, or commission any portion of the robotics system may result in equipment damage and/or serious injury. Any such attempts may void product warranties.

This section includes the following procedures:

- **“General Inspection and Cleaning”**
- **“Disassembling the Dolly”**
- **“Reassembling the Dolly”**
- **“Replacing the Main FRU”**
- **“Replacing the Drive Wheel Units”**
- **“Replacing the Passive Wheel Units”**

General Inspection and Cleaning

Furio Dolly systems are designed to be virtually maintenance free.

We suggest you periodically perform the following general inspection and cleaning tasks:

- Clean the wheels using a dry foam brush to remove any debris from the soft wheel material, and then wipe with a water-dampened cloth to remove any remaining dirt, dust, or grime.
- Inspect the wheels for wear, and replace wheel sets if required.
Furio dolly wheels are made of pliable silicone rubber, which wears over time.
- Use a slightly water-dampened cloth to remove dirt, dust, and grime from the rails.
- Wipe dust off the dolly, lift, and head using a slightly damp cloth only. Use only clean water to dampen the cloth. Do not use cleaning agents.
- Inspect the payload to ensure no components have shifted and that all fasteners are tightened appropriately.
- Check that all electrical connectors are secured properly.
- Inspect the cable bundle to detect signs of wear. Replace any damaged cables, and replace the cable sock if there are signs of excessive wear.
- Check that cables running to the head and payload are properly dressed. Slowly move the robot through its full range of motion to verify that cables are never pulled taut.

Disassembling the Dolly

Before You Begin:

- Move the dolly to a location that allows easy access to the drive wheel side.
- Ensure the dolly is on a straight portion of the track that allows ample space to work.
- Lower the lift completely, turn the dolly off, and disconnect the dolly power cable.
Note: Record the position of each cable as you remove it so you can later restore them to their original positions.
Tip: Don't forget to reconnect the power cable when you are finished servicing the dolly.

Step 1: Removing the Wiredraw Cable (If Applicable)

Remove the Wiredraw Cable

1. Move the dolly as close to the wiredraw as possible before detaching the cable.
2. Use a 6 mm hexagonal wrench to remove the bolt that secures the wiredraw cable to the dolly while holding the wiredraw.
Note: Grasp the cable end tightly, but do not wrap it around your hand or bend it.
IMPORTANT: Handle the wiredraw cable with care to avoid permanently damaging the cable and wiredraw unit. NEVER allow the cable to snap back into the wiredraw unit. If you release the cable and it snaps back into the wiredraw unit, the unit may be irreparably damaged.
3. Hold the cable close to the floor and parallel to the track to avoid rubbing of the steel cable against the wiredraw enclosure box, protecting the cable from damage.
4. Slowly walk the cable back to the wiredraw unit. Do not allow it to snag or rub against anything, except the part of the rail it normally contacts (curved tracks only).

Step 2: Removing the Robotic Head and Payload

Remove the Payload

1. Disconnect all cables from the payload and the robotic head, noting the position of each cable as you remove it so you can later restore them to their original positions.
2. Use the grease pencil to mark the position of the payload on the camera cradle (refer to **Figure 20**), and then remove the payload. Marking the payload position enables you to return it to its exact original position, which is especially important if it is part of a Virtual Studio / Augmented Reality (VS/AR) solution.

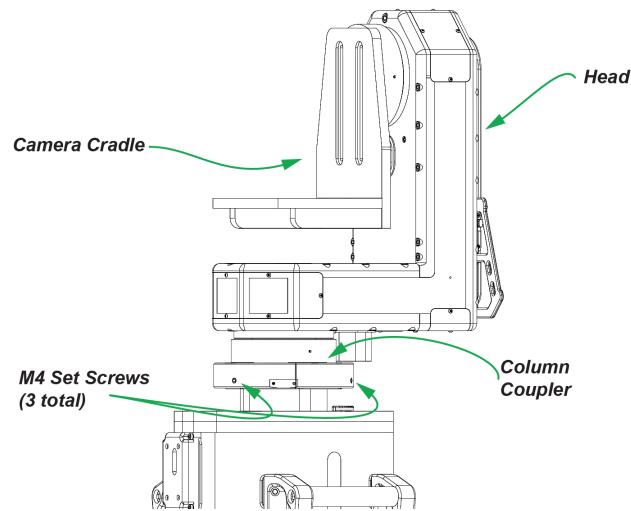

Figure 20 - Robotic Head

Remove the Robotic Head

1. Use the grease pencil to mark where the head/column coupler meets the top of the lift column so you can later realign them.
2. While another person holds the head steady, use the 4 mm hexagonal wrench to loosen the three M4 set screws along the edge of the head/column coupler, until the head is loose enough to remove from the lift column. Refer to **Figure 20** above.
3. Remove the head by lifting it straight up.

Step 3: Removing the Robotic Lift Column

Remove the Lift Column

1. **For a Robotic Lift Column:** Using the 8 mm hexagonal wrench, remove the four M10 base plate bolts that fasten the lift to the dolly base, as shown in **Figure 21**.
2. **For a Fixed Column:** Using the 6 mm hexagonal wrench for the fixed column, remove the M10 Flat Head base plate bolts.
3. Using the handles, lift the robotic lift column straight up until all of it is above the dolly, and then move the lift column aside and lay it down gently on its side.

CAUTION: The lift column is heavy. Get help when handling heavy items.

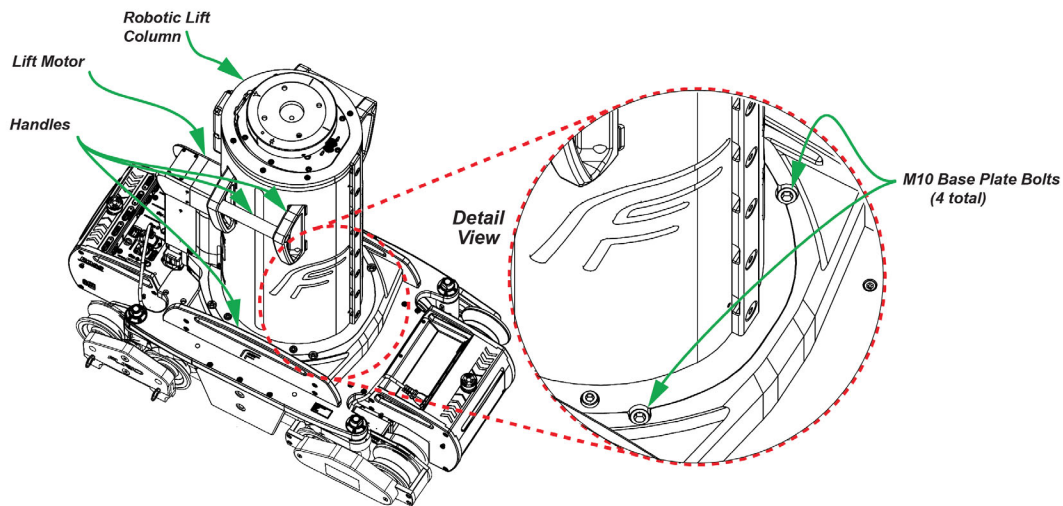

Figure 21 - M10 Base Plate Bolts Connecting the Lift to the Dolly

Step 4: Removing the Stability Arms or Wheels

There are two sliding passive wheel sets on the dolly, each containing either stability arms or wheels, depending on your Furio configuration, which ensure the wheels are securely fixed to the track. Refer to **Figure 22**.

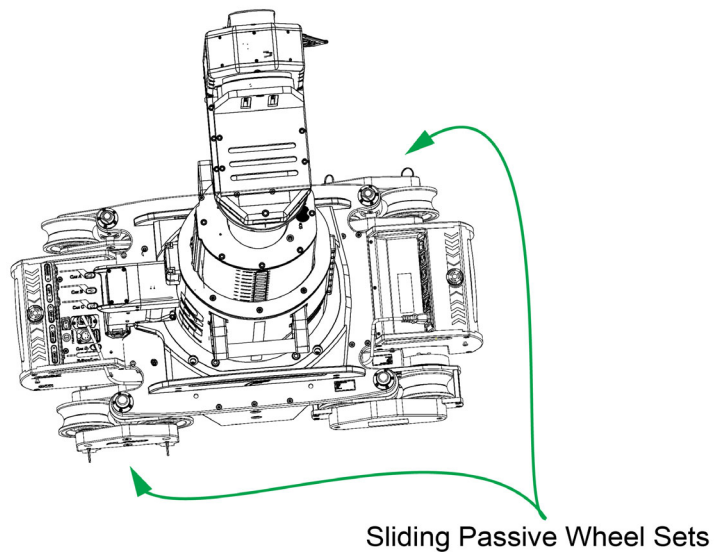

Figure 22 - Sliding Passive Wheels with Stability Wheels

Removing these arms or wheels allows the dolly to be lifted from the track.

For stability arm removal, proceed to "**Remove the Stability Arms**".

For stability wheel removal, proceed to "**Remove the Stability Wheels**".

Remove the Stability Arms

For the two sliding passive wheel sets, complete the following:

1. Locate the stability arms.
2. Remove all locking pins and stability arms on the passive sliding wheel sets.
Refer to **Figure 23**.

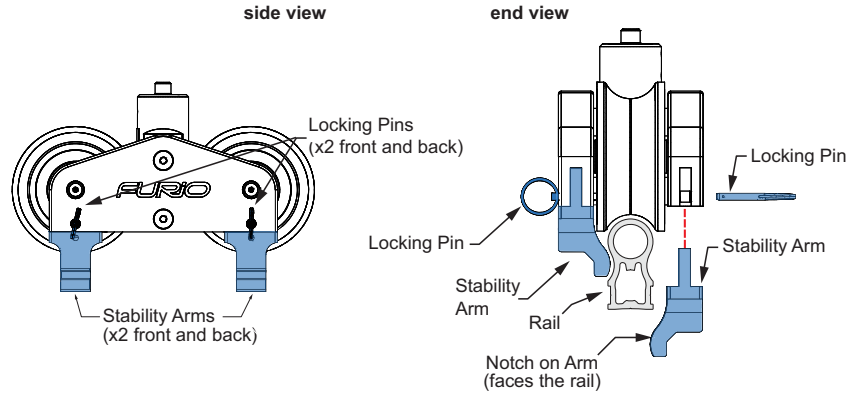

Figure 23 - Removing Stability Wheels

Remove the Stability Wheels

For the two sliding passive wheel sets, complete the following:

1. Locate the stability wheel.
2. Remove the locking pin by pressing and holding the pin lock button while sliding the locking pin out.
Refer to **Figure 24**.

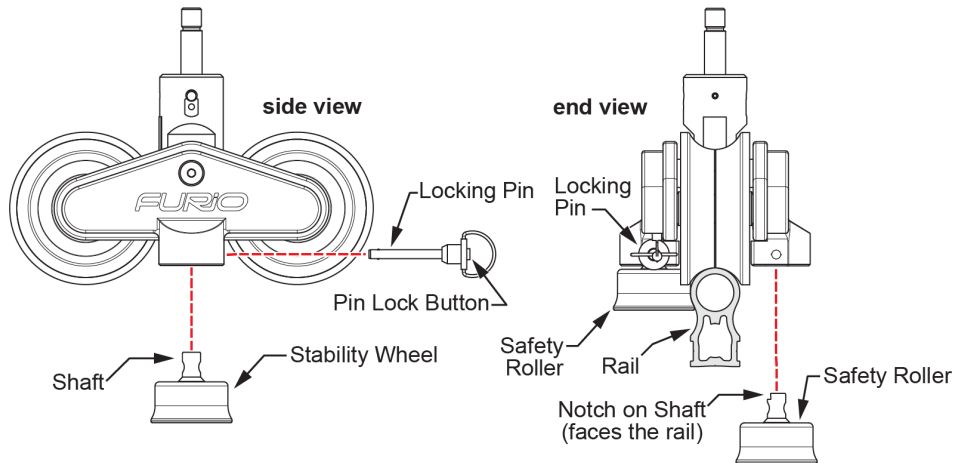

Figure 24 - Removing Stability Wheels

Reassembling the Dolly

Step 1: Reattaching the Stability Arms or Wheels

With the drive wheel set successfully installed and the dolly secured on the track, you can now reattach the stability arms or wheels, depending on your Furio system configuration. Note that only the two sliding passive wheels have stability wheels. Refer to **Figure 22** above.

Attach the Stability Arms

For the two sliding passive wheel sets, complete the following:

1. Insert the shaft of the stability arm into its hole.
2. Ensure the notch on the shaft faces the rail.
3. Slide the locking pins into their holes.

Refer to **Figure 25**.

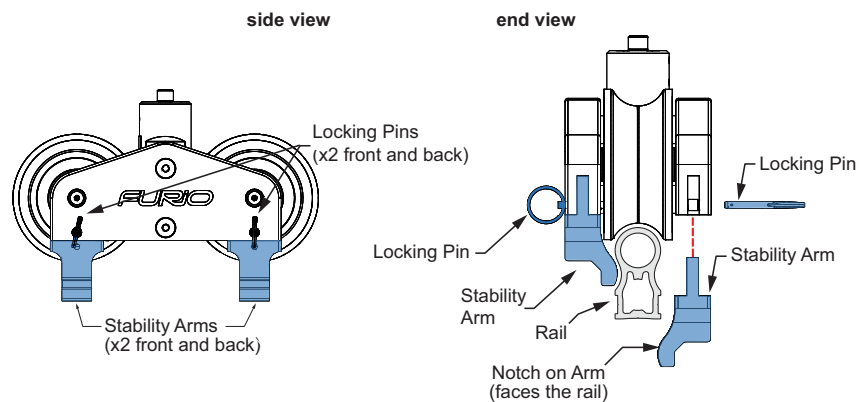

Figure 25 - Attaching Stability Wheels

Attach the Stability Wheels

For the two sliding passive wheel sets, complete the following:

1. Insert the shaft of the stability wheel into its hole.
2. Rotate the stability wheel shaft so the notch on the shaft faces the drive wheel set.
3. Pull and hold the pin lock button, then slide the locking pin into its hole.

Refer to **Figure 26**.

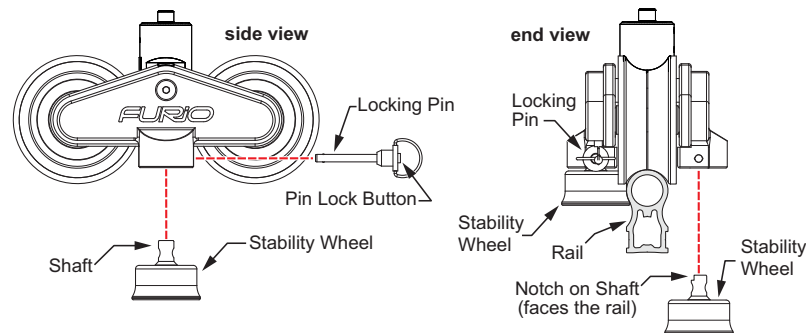

Figure 26 Attaching Stability Wheels

Step 2: Installing the Main FRU

Install the Main FRU

1. Align the runners of the new Main FRU with the guide rails within the body of the dolly, and then slowly slide the Main FRU into place. Continue until the Main FRU is fully inserted.

Tip: When the main FRU is fully inserted, the four mounting holes on the top of the dolly base align perfectly with the mounting holes on the Main FRU.

2. Insert and tighten the four mounting screws you removed using a 5 mm hexagonal wrench, as shown in **Figure 27**.

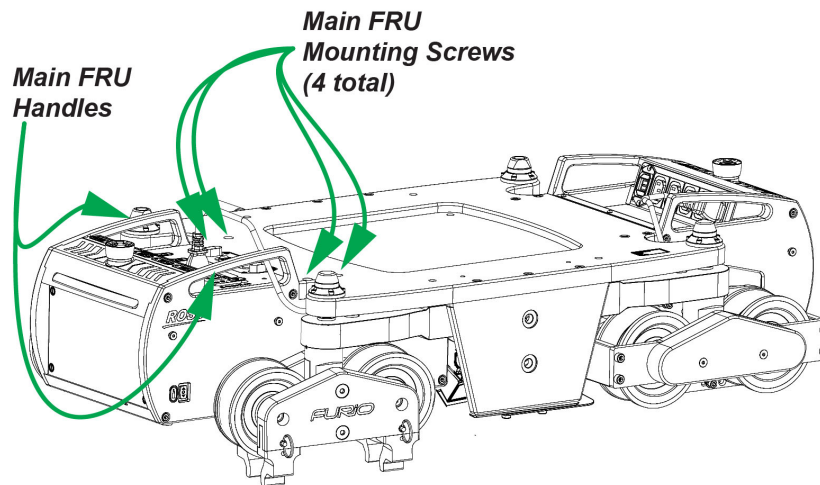

Figure 27 - Furio SE Dolly Base, showing Four Mounting Screws that Secure the Main FRU

3. Reconnect all cables to the Main FRU.

IMPORTANT: Ensure that all cables are reconnected to their original positions.

Step 3: Attaching the Wiredraw Cable

Attach the Wiredraw Cable

1. Obtain the wiredraw cable from the wiredraw unit and hold it.

Note: Grasp the cable end tightly, but do not wrap it around your hand or bend it.

IMPORTANT: Handle the wiredraw cable with care to avoid permanently damaging the cable and wiredraw unit. NEVER allow the cable to snap back into the wiredraw unit. If you release the cable and it snaps back into the wiredraw unit, the unit may be irreparably damaged.

2. Hold the cable close to the floor and parallel to the track to avoid rubbing of the steel cable against the wiredraw enclosure box, protecting the cable from damage.
3. Slowly feed the cable into the wiredraw mount. Do not allow it to snag or rub against anything, except the part of the rail it normally contacts (curved tracks only).
4. Use 6 mm hexagonal wrench and associated bolt to attach wire draw to the bracket.

Step 4: Installing the Lift

Install the Lift

1. Using the handles, lift the robotic lift column straight up until all of it is above the dolly.

CAUTION: The lift column is heavy. Get help when handling heavy items.

2. **For a Fixed Column:** Using the 6 mm hexagonal wrench for the fixed column, tighten the M10 Flat Head base plate bolts.
3. **For a Robotic Lift:** Using the 8 mm hexagonal wrench for the lift, tighten the four M10 base plate bolts (shown in **Figure 28**).

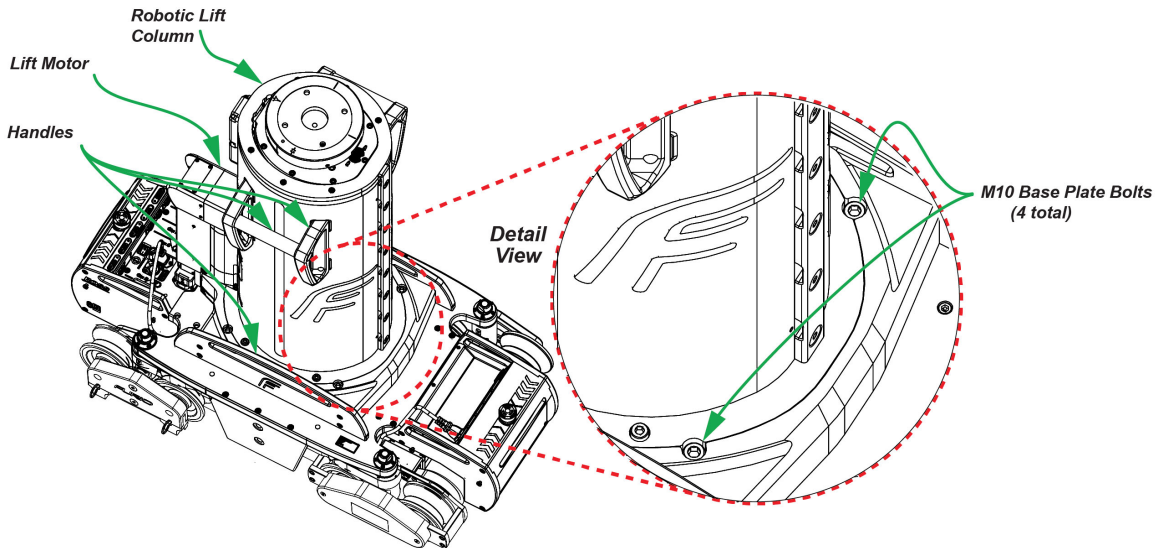

Figure 28 - M10 Base Plate Bolts Connecting the Lift to the Dolly

Step 5: Installing the Robotic Head and Payload

Install the robotic head

1. Use the mark made in "**Remove the Robotic Head**" as a guide for where the head/column coupler meets the top of the lift column to align them.
2. While another person holds the head steady, use the 4 mm hexagonal wrench to tighten the three M8 set screws along the edge of the head/column coupler, until the head is secure, as shown in **Figure 29**.
3. Attach the payload components.
4. Connect all cables from the payload and the robotic head, noting the position of each cable as you remove it so you can later restore them to their original positions.

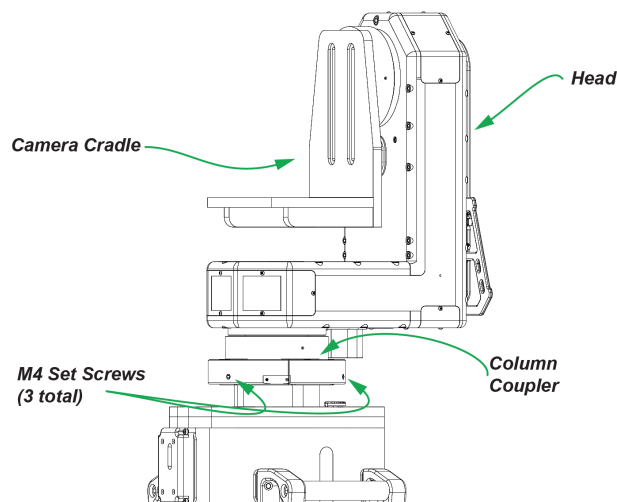

Figure 29 - Robotic Head

Install the payload

1. Move the dolly to a location that allows easy access to all sides of the dolly.
2. Use the grease pencil mark from **"Remove the Payload"** as a position marker for the payload and then add the payload, as shown in **Figure 29**.

Note: Using the marked payload position enables you to return it to its exact original position, which is especially important if it is part of a Virtual Studio / Augmented Reality (VS/AR) solution.

3. Connect all cables from the dolly's connection panel, noting the position of each cable as you've added and referring to their original positions documented from **"Remove the Payload"**.

Replacing the Main FRU

The **Main FRU** contains all the control electronics. All network and power connections for the dolly, lift, and head are through the Main FRU's connection panel (**Figure 30**).

If the Main FRU malfunctions, you can easily replace it with a different one. This section describes how to remove and replace the Main FRU.

Removing and replacing the Main FRU takes approximately 20 minutes.

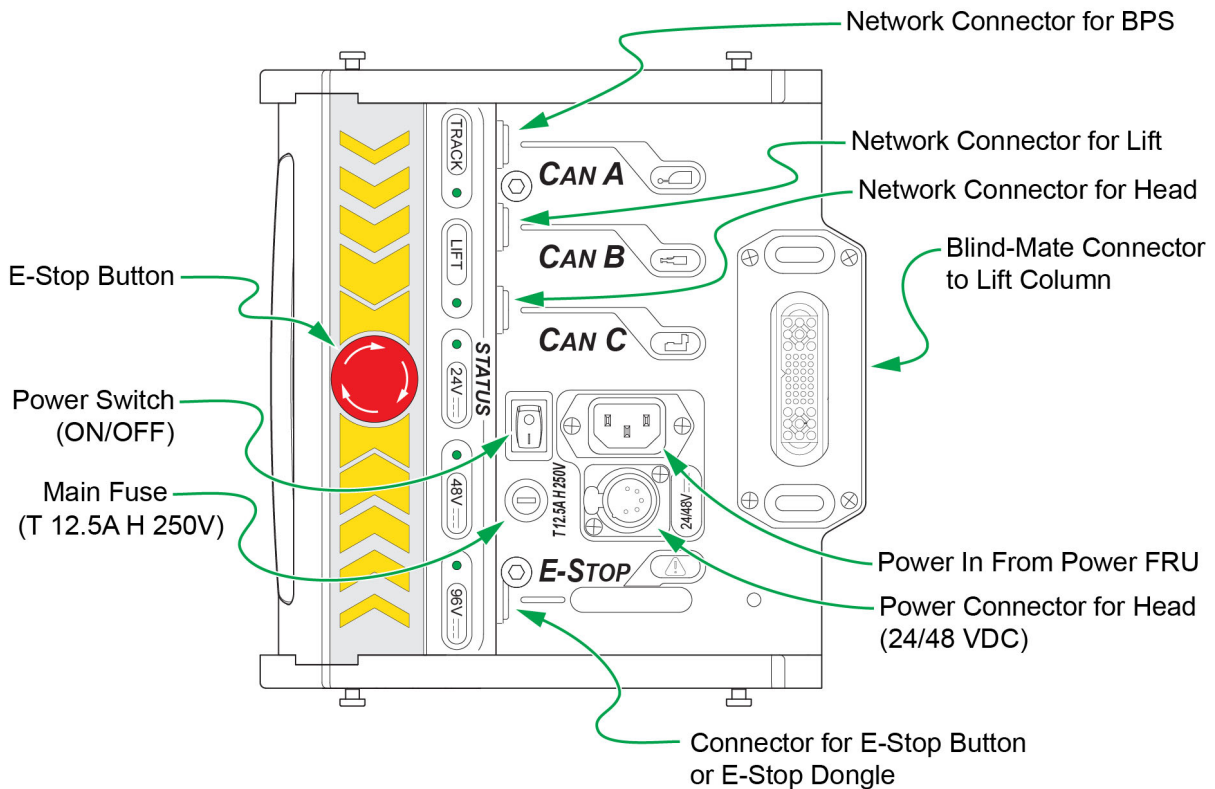

Figure 30 - Furio SE Dolly Main FRU Connection Panel

Before you begin:

1. Read all steps and ensure that you understand them.
If you have any questions, contact Ross Video Technical Support.
2. Have the following tools and materials available:
 - 3 mm hex key (also known as an Allen key or hexagonal key wrench)

- Replacement Main FRU, with appropriate configuration files installed.
For more information, contact Technical Support.
3. Move the dolly to a location on the track that allows ample space to work.

To remove and replace the Main FRU:

1. Turn off the dolly, and then disconnect the Main FRU's Power In cable (**Figure 30**).
2. Disconnect all other cables from the Main FRU.

Tip: Ensure that each cable is labeled, so they're easy to reconnect later.

3. If the dolly has a robotic lift, disengage the lift lock connector (**Figure 31**).

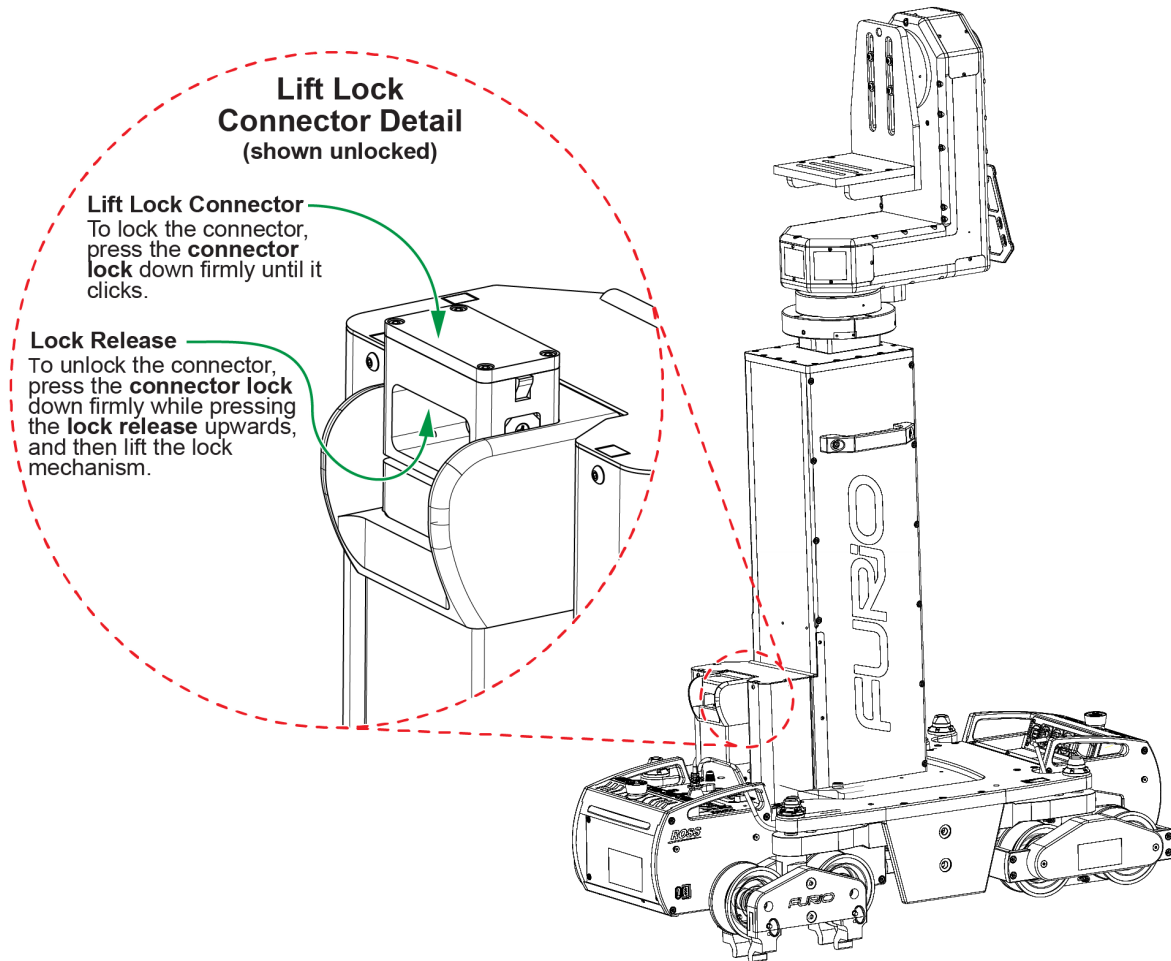

Figure 31 - Furio SE Dolly with S2 Lift, showing Lift Lock Connector Detail

4. Use a 3 mm hex key to remove the four screws that secure the Main FRU to the dolly.

Figure 32 shows the four mounting screws (colored blue in the drawing for illustrative purposes).

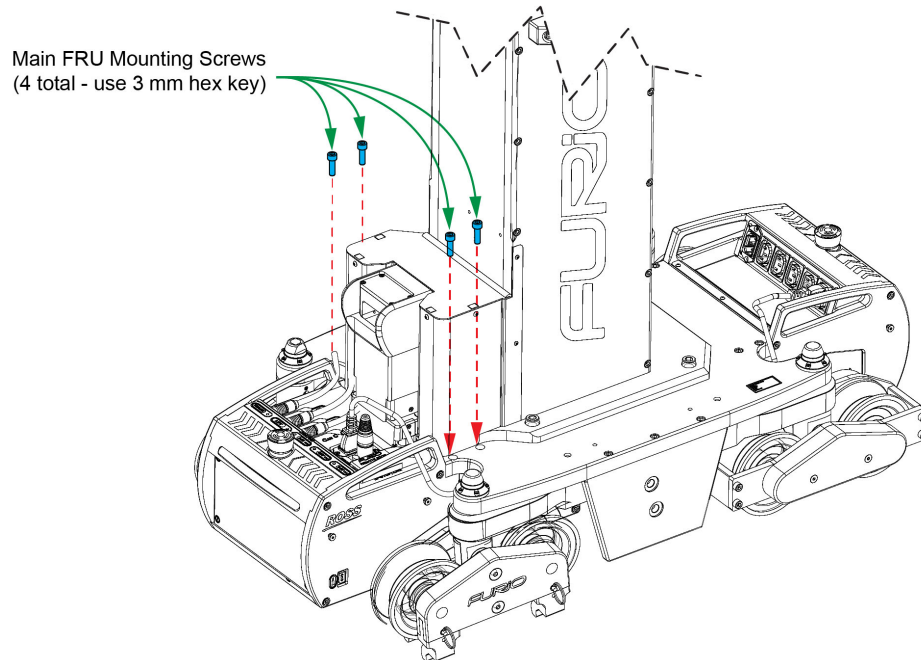

Figure 32 - Furio SE Dolly, showing Four Mounting Screws that Secure the Main FRU

5. Grasp the handles on the Main FRU, and then slowly slide it out from the body of the dolly.

Tip: The Main FRU has two runners that ride on guide ledges within the body of the dolly. Be prepared to catch the Main FRU as it disengages from the body of the dolly.

IMPORTANT: Store the removed Main FRU in a safe location, away from moisture and extreme temperatures.

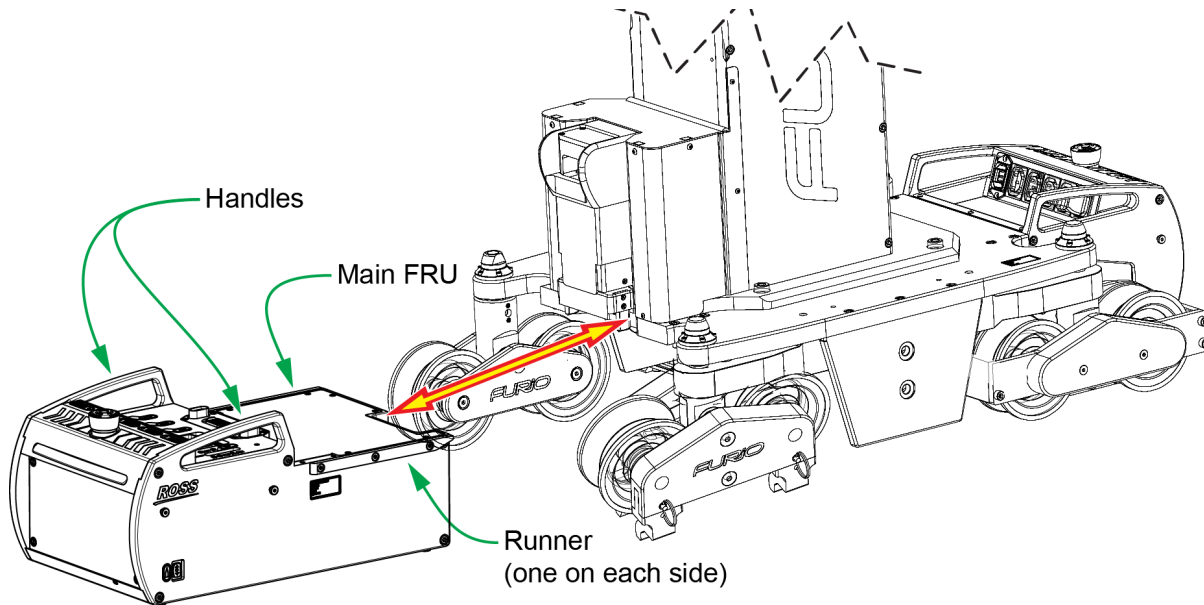

Figure 33 - Removing the Main FRU from the Furio SE Dolly

6. Align the runners of the new Main FRU with the guide ledges within the body of the dolly, and then slowly slide the Main FRU into place. Continue until the Main FRU is fully inserted.

Tip: When the main FRU is fully inserted, the four mounting holes on the top of the dolly base align perfectly with the mounting holes on the Main FRU.

7. Insert and tighten the four mounting screws you removed in **step 4** on **page 41**, using a 3 mm hex key.
8. If the dolly has a robotic lift, engage the lift lock connector (see **Figure 31** on **page 40**).
9. Reconnect all cables to the Main FRU.

IMPORTANT: Ensure that all cables are reconnected to their original positions.

10. Turn on the Main FRU and then test the robot's operation.

Replacing the Drive Wheel Units

Replacing the drive wheel unit on the Furio dolly involves removing the stability solution, detaching the drive wheel set, and transferring the motor unit to the new drive wheel.

This process takes approximately 30 minutes and requires two people. It's essential to follow the correct safety procedures, such as turning off the dolly and using proper lifting techniques to prevent injury or damage to the equipment.

For detailed, step-by-step instructions, refer to the appropriate guide for your system configuration:

- ***Furio Drive Wheel Replacement with StableTrac (5100DR-015-04)*** for dollies with StableTrac
- ***Furio Drive Wheel Replacement (5100DR-099-01)*** for dollies without StableTrac

Replacing the Passive Wheel Units

Replacing the passive wheel units on the Furio SE dolly is a necessary maintenance task that involves safely removing and reinstalling the passive wheels on both the fixed and StableTrac sides of the dolly.

This process requires careful disassembly of the stability solution, the removal of the passive wheel units, and their replacement using appropriate tools and procedures.

The operation takes approximately one hour per dolly, and it's important to follow all safety guidelines, including lifting the dolly correctly and handling heavy components with assistance.

For detailed, step-by-step instructions, refer to the appropriate guide for your system configuration:

- ***Furio Passive Wheel Replacement (5100DR-016-02)*** for dollies with StableTrac
- ***Furio Passive Wheel Replacement (5100DR-016-01)*** for dollies without StableTrac

Technical Specifications

Each Furio Dolly system is sold as a product package that includes a Furio SE Dolly and a Furio robotic pan and tilt head. The product package may also include a robotic lift.

Furio Dolly product packages are as follows:

- **FRO-X350-ST-DLY-SE** — Furio X350 pan and tilt head mounted on a Furio SE robotic dolly. The head mounts to the dolly via a mounting adapter (included), or via a fixed-height column (optional accessory).
- **FRO-X350-ST-FULL-SE** — Furio X350 pan/tilt head atop a Furio SE three-stage robotic lift, all mounted on a Furio SE robotic dolly.
- **FRO-X350-ST-FULL-S2** — Furio X350 pan/tilt head atop a S2 two-stage robotic lift, all mounted on a Furio SE robotic dolly.
- **FRO-VR600-DLY-SE** — Furio VR600 pan and tilt head mounted on a Furio SE robotic dolly. The head mounts to the dolly via a mounting adapter (included).
- **FRO-VR600-FULL-SE** — Furio VR600 pan/tilt head atop a Furio SE three-stage robotic lift, all mounted on a Furio SE robotic dolly.
- **FRO-VR600-FULL-S2** — Furio VR600 pan/tilt head atop a S2 two-stage robotic lift, all mounted on a Furio SE robotic dolly.

Track layouts are custom-designed for each installation. Track and BPS components are sold separately from the Furio Dolly product packages.

This section provides technical specifications for each product package, and for track and BPS components:

- **"FRO-X350-DLY-SE Product Package"**
- **"FRO-X350-FULL-SE Product Package"**
- **"FRO-X350-FULL-S2 Product Package"**
- **"FRO-VR600-DLY-SE Product Package"**
- **"FRO-V600-FULL-S2 Product Package"**
- **"FRO-V600-FULL-S2 Product Package"**
- **"Furio Track and BPS Components"**
- **"Legacy Components and Accessories"**

For information on **Electrical and Environmental Specifications**, refer to

Product Packages

FRO-X350-DLY-SE Product Package

The following table lists technical specifications for the X350 product package.

Component	Property	Description / Value
Robotic Head	Robotic Head Type	Furio X350 robotic pan and tilt head
	Maximum Net Payload	6.8 kg (15 lbs)
	Maximum Prompter Size	N/A
	Minimum/Maximum Pan Speed	0.01 - 45 degrees per second
	Minimum/Maximum Tilt Speed	0.01 - 45 degrees per second
	Pan/Tilt Repeatability	+/- 0.05 degrees
	Pan/Tilt Angular Range	±179° pan range and ±90° tilt range
Dolly/Head	Height to Center of Tilt Axis Dolly + X350 Head	52.8 cm (20.8")
	Position Tracking for VS/AR	Yes
Furio SE Dolly	Track Repeatability	<1 cm (absolute positioning)
	Dolly/Base Size (Length x Width x Height)	89 cm x 46 cm x 23 cm (34.9" x 18" x 9") (Furio SE dolly only, without lift or head)
	Maximum Track Speed	Speed depends on payload and track length: <ul style="list-style-type: none"> • 1 - 2.5 m/s (36 - 96 in/s) on straight track • 0.5 - 1 m/s (18 - 39 in/s) on curved track

FRO-X350-FULL-SE Product Package

The following table lists technical specifications for the FRO-X350-FULL-SE product package.

Component	Property	Description / Value
Robotic Head	Robotic Head Type	Furio X350 robotic pan and tilt head
	Maximum Net Payload	6.8 kg (15 lbs)
	Maximum Prompter Size	N/A
	Minimum/Maximum Pan Speed	0.01 - 45 degrees per second
	Minimum/Maximum Tilt Speed	0.01 - 45 degrees per second
	Pan/Tilt Repeatability	+/- 0.05 degrees
	Pan/Tilt Angular Range	±179° pan range and ±90° tilt range
Furio SE Lift	Lift Type	Three-stage
	Lift Total Range	86.5 cm (34.1")

Component	Property	Description / Value
Dolly/Lift/Head	Height to Center of Tilt Axis Dolly + SE Lift + X350 Head	Maximum: 202.4 cm (79.7") Minimum: 115.9 cm (45.7")
	Position Tracking for VS/AR	Yes
Furio SE Dolly	Track Repeatability	< 1cm (absolute positioning)
	Dolly/Base Size (Length x Width x Height)	89 cm x 46 cm x 23 cm (34.9" x 18" x 9") (Furio SE dolly only, without lift or head)
	Maximum Track Speed	Speed depends on payload and track length: • 1 - 2.5 m/s (36 - 96 in/s) on straight track • 0.5 - 1 m/s (18 - 39 in/s) on curved track

FRO-X350-FULL-S2 Product Package

The following table lists technical specifications for the FRO-X350-FULL-S2 product package.

Component	Property	Description / Value
Robotic Head	Robotic Head Type	Furio X350 robotic pan and tilt head
	Maximum Net Payload	6.8 kg (15 lbs)
	Maximum Prompter Size	N/A
	Minimum/Maximum Pan Speed	0.01 - 45 degrees per second
	Minimum/Maximum Tilt Speed	0.01 - 45 degrees per second
	Pan/Tilt Repeatability	+/- 0.05 degrees
	Pan/Tilt Angular Range	±179° pan range and ±90° tilt range
Furio S2 Lift	Lift Type	Two-stage
	Lift Total Range	48.3 cm (19")
Dolly/Lift/Head	Maximum Height to Optical Camera Center Dolly + S2 Lift + X350 Head	Maximum: 161.9cm (63.7") Minimum: 113.7cm (44.8")
	Position Tracking for VS/AR	Yes
Furio SE Dolly	Track Repeatability	<1cm (absolute positioning)
	Dolly/Base Size (Length x Width x Height)	89 cm x 46 cm x 23 cm (34.9" x 18" x 9") (Furio SE dolly only, without lift or head)
	Maximum Track Speed	Speed depends on payload and track length: • 1 - 2.5 m/s (36 - 96 in/s) on straight track • 0.5 - 1 m/s (18 - 39 in/s) on curved track

FRO-VR600-DLY-SE Product Package

The following table lists technical specifications for the FRO-VR600-DLY-SE product package.

Component	Property	Description / Value
Robotic Head	Robotic Head Type	Furio VR600 robotic pan and tilt head
	Maximum Net Payload	30 kg (66 lbs)
	Maximum Prompter Size	48 cm (19")
	Minimum/Maximum Pan Speed	0.001 - 90 degrees per second
	Minimum/Maximum Tilt Speed	0.001 - 90 degrees per second
	Pan/Tilt Repeatability	<0.02 degrees
	Pan/Tilt Angular Range	±358° pan range and ±90° tilt range
Dolly/Head	Height to Center of Tilt Axis Dolly + VR600 Head	63.3 cm (24.9")
	Position Tracking for VS/AR	Yes
Furio SE Dolly	Track Repeatability	<1 cm (absolute positioning)
	Dolly/Base Size (Length x Width x Height)	89 cm x 46 cm x 23 cm (34.9" x 18" x 9") (Furio SE dolly only, without lift or head)
	Maximum Track Speed	Speed depends on payload and track length: <ul style="list-style-type: none"> • 1 - 2.5 m/s (36 - 96 in/s) on straight track • 0.5 - 1 m/s (18 - 39 in/s) on curved track

FRO-V600-FULL-S2 Product Package

The following table lists technical specifications for the FRO-VR600-FULL-S2 product package.

Component	Property	Description / Value
Robotic Head	Robotic Head Type	Furio VR600 robotic pan and tilt head
	Maximum Net Payload	30 kg (66 lbs)
	Maximum Prompter Size	48 cm (19")
	Minimum/Maximum Pan Speed	0.001 - 90 degrees per second
	Minimum/Maximum Tilt Speed	0.001 - 90 degrees per second
	Pan/Tilt Repeatability	<0.02 degrees
	Pan/Tilt Angular Range	±358° pan range and ±90° tilt range
Furio S2 Lift	Lift Type	Two-stage
	Lift Total Range	48.3 cm (19")

Component	Property	Description / Value
Dolly/Lift/Head	Maximum Height to Optical Camera Center Dolly + S2 Lift + VR600 Head	Maximum: 223cm (87.8") Minimum: 136.5cm (53.7")
	Position Tracking for VS/AR	Yes
Furio SE Dolly	Track Repeatability	<1cm (absolute positioning)
	Dolly/Base Size (Length x Width x Height)	89 cm x 46 cm x 23 cm (34.9" x 18" x 9") (Furio SE dolly only, without lift or head)
	Maximum Track Speed	Speed depends on payload and track length: • 1 - 2.5 m/s (36 - 96 in/s) on straight track • 0.5 - 1 m/s (18 - 39 in/s) on curved track

FRO-V600-FULL-S2 Product Package

The following table lists technical specifications for the FRO-VR600-FULL-S2 product package.

Component	Property	Description / Value
Robotic Head	Robotic Head Type	Furio VR600 robotic pan and tilt head
	Maximum Net Payload	30 kg (66 lbs)
	Maximum Prompter Size	48 cm (19")
	Minimum/Maximum Pan Speed	0.001 - 90 degrees per second
	Minimum/Maximum Tilt Speed	0.001 - 90 degrees per second
	Pan/Tilt Repeatability	<0.02 degrees
	Pan/Tilt Angular Range	±358° pan range and ±90° tilt range
Furio S2 Lift	Lift Type	Two-stage
	Lift Total Range	48.3 cm (19")
Dolly/Lift/Head	Maximum Height to Optical Camera Center Dolly + S2 Lift + VR600 Head	Maximum: 182.6cm (71.9") Minimum: 134.4cm (52.9")
	Position Tracking for VS/AR	Yes
Furio SE Dolly	Track Repeatability	<1cm (absolute positioning)
	Dolly/Base Size (Length x Width x Height)	89 cm x 46 cm x 23 cm (34.9" x 18" x 9") (Furio SE dolly only, without lift or head)
	Maximum Track Speed	Speed depends on payload and track length: • 1 - 2.5 m/s (36 - 96 in/s) on straight track • 0.5 - 1 m/s (18 - 39 in/s) on curved track

Furio Track and BPS Components

Track layouts are custom-designed for each installation. Track and BPS components are sold separately from Furio SE Dolly product packages.

The following table lists technical specifications for Furio track and BPS components:

Component	Property	Description / Value
Furio Track	Maximum Track Length	30m (98')
	Minimum/Maximum Radius for Curved Track	Minimum 3 m (9.8 ft) to centerline of outside rail, which corresponds to 2.64 m (8.6 ft) to centerline of inside rail. Maximum radius is unlimited. Any radius or track section can be custom built.
	Dolly Track Width	36 cm (14.17") Note: Allow for cable bundle running alongside track, and Furio Cable Fence (if equipped - optional accessory).
Barcode Tape	Barcode Tape Length	Barcode tapes are available to order in the following lengths: <ul style="list-style-type: none"> • 10 meters (FRO-BPS-TAPE-10) • 20 meters (FRO-BPS-TAPE-20) • 30 meters (FRO-BPS-TAPE-30) • 40 meters (FRO-BPS-TAPE-40) • 50 meters (FRO-BPS-TAPE-50) • 70 meters (FRO-BPS-TAPE-70)
	Barcode Tape Proximity to Bumper	The barcode tape does not need to start immediately after the bumper. You can leave a gap of a few barcodes in length (approximately 50 to 170 mm from the BPS). However, ensure that the BPS scanner can still read the barcodes when the dolly is positioned as far back on the track as possible.

Legacy Components and Accessories

Track layouts are custom-designed for each installation. Track and BPS components are sold separately from Furio SE Dolly product packages.

The following components and accessories, while still compatible with existing Furio systems, have been replaced by newer models. Customers may continue to use them in their current setups or choose to upgrade to the latest versions for improved performance and functionality.

Legacy components and accessories include:

- **Stability Wheels**

Stability wheels were used on earlier Furio systems to grip the track and prevent tipping during movement. These wheels were part of the passive sliding wheel sets but have since been replaced by stability arms, which ship by default with all Furio dollies.

- **Wiredraw**

The wiredraw was previously used to track the position of the dolly along the track. As of July 2024, it has been replaced by the Barcode Positioning System (BPS), which offers enhanced precision, reliability, and easier maintenance.

- **VR100 Robotic Head**

The VR100 robotic pan and tilt head was used for lighter payloads, with a maximum payload capacity of 20 kg. This head is compatible with virtual sets and augmented reality applications, but newer models such as the VR600 provide higher payload capacity and improved performance for more demanding setups.



- **Talent Monitor Mounting Bracket for Dolly**

This bracket was used to mount monitors onto Furio SE dollies and is only compatible with systems that include a lift or a tall fixed-height column. It is no longer supported for new installations.

For information on these parts, refer to the previous technical manual, ***Technical Manual for Robotic Dolly Systems 510DR-043-02***.

Electrical and Environmental Specifications

The Furio Camera Motion Systems series includes three systems—Furio Floor-Mount Rail, Furio BlackBird, and Furio SkyDolly—designed to carry and control camera and teleprompter payloads, offering precise pan, tilt, zoom, and path-following capabilities for dynamic shots in various environments like film production, live events, and TV studios. All systems share common components, with the primary difference being the dolly’s mechanical design.

	Furio Floor-Mount Rail System	Furio SkyDolly Ceiling-Mounted Rail System	Furio BlackBird Elevation System
Full system view		 For more information on Furio SkyDolly Systems, refer to the <i>Technical Manual for Furio SkyDolly (5100DR-074-03)</i> .	 For more information on Furio SkyDolly Systems, refer to the <i>Technical Manual for BlackBird SE/S2 Pedestal (5100DR-101-01)</i> .
Remote controlled movements (by an operator)	1) X axes through traction motor on the Dolly 2) Z axes through a motor on the Lift 3) Pan & Tilt through the Head where the payload is mounted.		1) Z axes through a motor on the Lift 2) Pan & Tilt through the Head where the payload is mounted.
Manual controlled movements (by an operator)	None		XY Axes
Differences	Floor-Mounted Rail motorized dolly	Ceiling-Mounted Rail motorized dolly	Non-motorized floor dolly

	Furio Floor-Mount Rail System	Furio SkyDolly Ceiling-Mounted Rail System	Furio BlackBird Elevation System
Product ratings	<p>Electrical Input rating: 12.5A, 100-240Vac, 50/60Hz</p> <p>Electrical Output rating (Power bar): 5A max, 100-240Vac, 50/60Hz</p> <p>Mechanical rating:</p> <ul style="list-style-type: none"> • X350: 5.3Kg Max Payload • VR600: 25Kg Max Payload <p>System Speed Rating:</p> <ul style="list-style-type: none"> • S2 Lift: 127mm/sec • SE Lift: 152mm/sec • X350 Pan & Tilt: 0.001 - 45 deg /sec. • VR600 Pan & Tilt: 0.001 -90 deg /sec. <p>Environmental ratings: 0°C to +40°C, 0% to 90% RH (non-condensing)</p>		
Input Ports	<p>Dollies: 1x Main AC input, 1x Remote E-Stop</p> <p>X350 Head: 1x 48Vdc input power, 2x Ethernet Ports, 1x Sync In Port, 1x CAN Control Port</p> <p>VR600 Head: 1x 48Vdc input power, 1x Ethernet Ports, 1x Sync In Port, 2x CAN Control Port</p> <p>Lidar System: 1x 12Cdc input power</p>		
Output Ports	<p>Dollies: 5x AC Main power bar, 1x Can (wiredraw),</p> <p>X350 Head: 1x 12Vdc output, 1x Serial Port, , 1x Sync Out Port, 2x Lens control ports</p> <p>VR600 Head: 1x Serial Port, , 3x Lens/Cam control ports</p>		

