



ARTIMO

Technical Manual

ROSS[®]

ART IN MOTION.

About Us

Thank You for Choosing Ross

You've made a great choice. We expect you will be very happy with your purchase of Ross Technology.

Our mission is to:

1. Provide a Superior Customer Experience
 - offer the best product quality and support
2. Make Cool Practical Technology
 - develop great products that customers love

Ross has become well known for the Ross Video Code of Ethics. It guides our interactions and empowers our employees. I hope you enjoy reading it below.

If anything at all with your Ross experience does not live up to your expectations be sure to reach out to us at solutions@rossvideo.com.



David Ross

CEO, Ross Video

dross@rossvideo.com

OPERATING GUIDELINES





Any company is the sum total of the people that make things happen. At Ross, our employees are a special group. Our employees truly care about doing a great job and delivering a high quality customer experience every day. This code of ethics hangs on the wall of all Ross Video locations to guide our behavior:

1. We will always act in our customers' best interest.
2. We will do our best to understand our customers' requirements.
3. We will not ship crap.
4. We will be great to work with.
5. We will do something extra for our customers, as an apology, when something big goes wrong and it's our fault.
6. We will keep our promises.
7. We will treat the competition with respect.
8. We will cooperate with and help other friendly companies.
9. We will go above and beyond in times of crisis. If there's no one to authorize the required action in times of company or customer crisis - do what you know in your heart is right. (You may rent helicopters if necessary.)

SAFETY







Important Notices

SYMBOL NOTICES

-  **Protective Earth:** This symbol identifies a Protective Earth (PE) terminal, which is provided for connection of the supply system's protective earth (green or green/yellow) conductor.
-  **Important:** This symbol on the equipment refers you to important operating and maintenance (servicing) instructions within the Product Manual Documentation. Failure to heed this information may present a major risk of damage or injury to persons or equipment
-  **Warning:** The symbol with the word "Warning" within the equipment manual indicates a potentially hazardous situation which, if not avoided, could result in death or serious injury
-  **CAUTION:** The symbol with the word "Caution" within the equipment manual indicates a potentially hazardous situation which, if not avoided, may result in minor or moderate injury. It may also be used to alert against unsafe practices.
-  **Warning Hazardous Voltages:** This symbol is intended to alert the user to the presence of uninsulated "Dangerous voltage" within the product enclosure that may be of sufficient magnitude to constitute a risk of shock to persons.

IMPORTANT REGULATORY AND SAFETY NOTICES TO USER AND SERVICE PERSONNEL

Before using this product and any associated equipment, refer to the "Important Safety Instructions" listed in this document to avoid personnel injury and to prevent product damage. Product may require specific equipment, and/or installation procedures to be carried out to satisfy certain regulatory compliance requirements. Notices have been included in this publication to call attention to these specific requirements.

-  **ESD Susceptibility:** This symbol is used to alert the user that an electrical or electronic device or assembly is susceptible to damage from an ESD event.
-  **Warning Hazardous Moving Parts:** This symbol is intended to alert the user to the presence of hazardous mechanical moving parts that can cut and crush. User shall not remove cover and shall keep hands/objects clear at all times during operation to avoid serious injuries.
-  **Warning Hazardous Belt Drive:** This symbol is intended to alert the user to the presence of hazardous Belt Drive motion that can nip, snag, crush. User shall not remove cover and shall keep hands/objects clear at all times during operation to avoid serious injuries.
-  **Warning Impact Hazard:** This symbol is intended to alert the user to the presence of a collision/impact hazard from a descending platform and parts. Lift shall not be disassembled without being completely lowered and locked in place with the safety mechanical interlock Pin.
-  **Warning Laser Hazard:** This symbol is intended to alert the user to the presence of a hazardous laser beam that can cause skin and vision damage. User shall not remove Laser cover and shall not look directly at the laser component during operation to avoid serious injuries.
-  **Warning Hazardous Robot motion:** This symbol is intended to alert the user to the presence of impact, crush and collision hazards that can occur when a safety distance is not maintained during system operation or servicing

Contents

INTRODUCING ARTIMO

OVERVIEW	1
FEATURES	2
ARTIMO ANATOMY	3
CONNECTION PANELS	4

CONTROL SYSTEMS

SMARTSHELL	6
CX-3R PANEL	7
LOCAL CONTROL	8

TECHNICAL DETAILS

SPECIFICATIONS	9
DIMENSIONS	10
SITE REQUIREMENTS	11
NAVIGATION SYSTEMS	12

MAINTENANCE

INSPECTION & CLEANING	13
MARKER INSTALLATION	14
WHEEL MAINTENANCE	15

SAFETY

HANDLING & OPERATING	16
EMERGENCY STOP	18
SAFETY FEATURES	19
IMPORTANT SAFETY NOTICES	20

SUPPORT

CONTACT	27
MANUAL DETAILS	28



Hello and welcome
to the show!

We have great
things planned for
you today



INTRODUCING ARTIMO

Overview

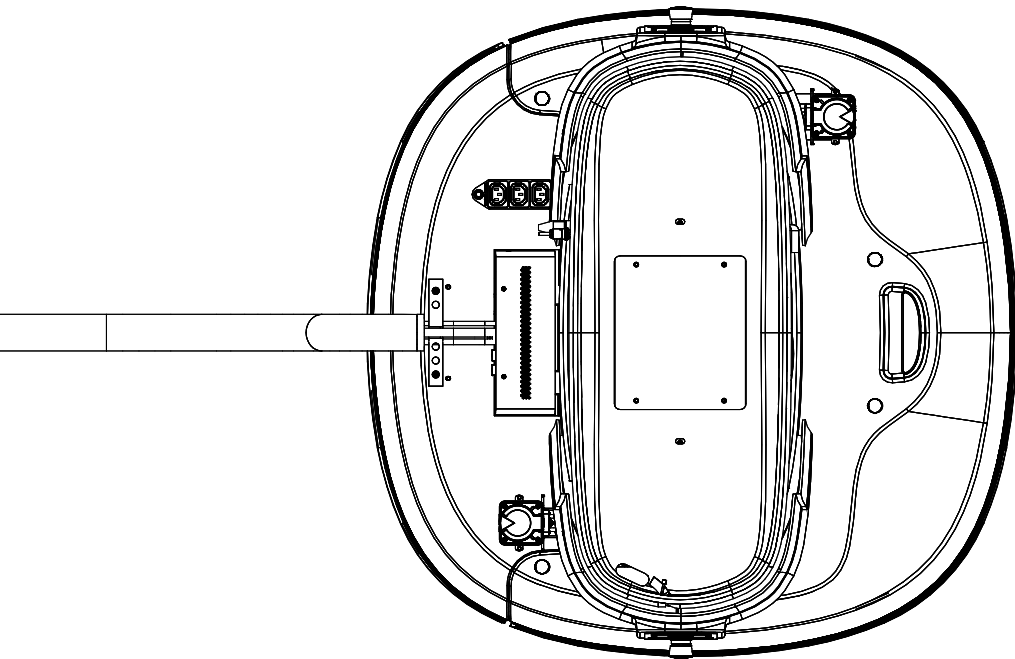

ABOUT ARTIMO

Artimo is a cutting-edge, free-roaming camera pedestal designed to deliver unparalleled flexibility and precision in live production environments.

Leveraging advanced lidar technology, Artimo navigates complex studio setups with ease, providing smooth, stable camera movements across a wide range of motion.

With a robust payload capacity and integrated tally light for live status indication, and seamless integration into existing control systems, Artimo sets a new standard for dynamic on-air camera operations.

INTRODUCING ARTIMO

Key Features

Dynamic Movement

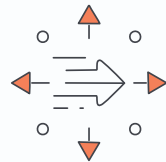

Extends from floor level to above head height, allowing a wide range of camera angles and creative shots without additional equipment.

Advanced Navigation



Utilizes geofencing and lidar for precise and intelligent navigation within the studio.

Smooth Operation

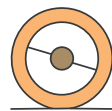

Engineered to move smoothly across various floor types, ensuring stable and jitter-free camera movements.

Payload Capacity



Supports up to 40 kg (88 lbs), accommodating cameras, lenses, teleprompters, and monitors.

User-Friendly Design



Includes a built-in touchscreen display, tally lights, and monitor brackets for ease of use and integration into studio workflows.

Cable Management

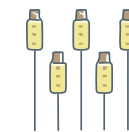

Features integrated cable management to maintain a clean and professional studio environment.

INTRODUCING ARTIMO

Anatomy

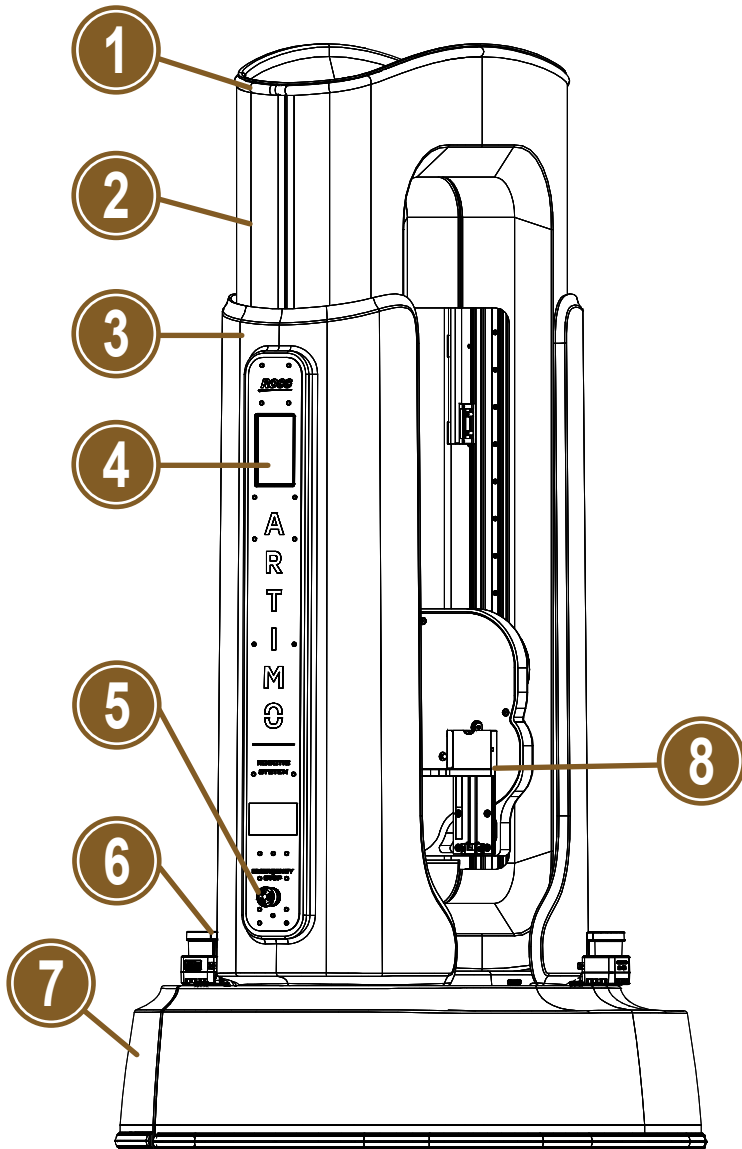

- ① INTEGRATED TALLY LIGHT
- ② DYNAMIC LIFT
- ③ STATIC LIFT
- ④ TOUCHSCREEN
- ⑤ EMERGENCY STOP (E-STOP)
- ⑥ LIDAR SENSOR
- ⑦ REMOVABLE BASE COWLING
- ⑧ CAMERA CRADLE

INTRODUCING ARTIMO

Connection Panels

Top Panels

- 1** ANALOG
(Analog Lens Control Port)
- 2** DIGITAL
(Digital Lens Control Port)
- 3** USB 2.0
- 4** SYNC IN/OUT
(Virtual Sets)
- 5** ETHERNET
(Accessories, ex. Camera)
- 6** CAMERA POWER
(12V CD, 6.25A MAX)

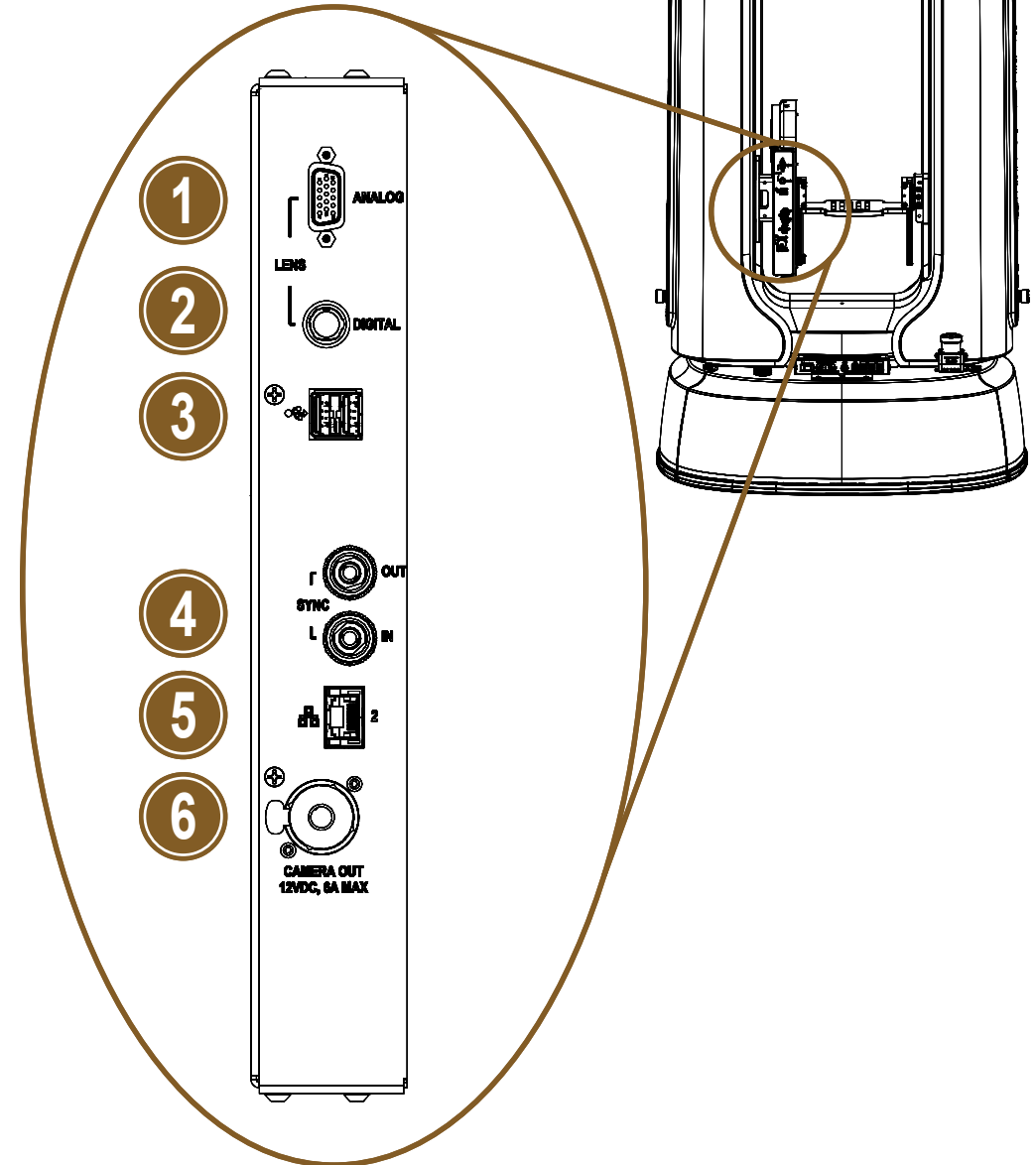

INTRODUCING ARTIMO

Connection Panels

Cowling Panels

- 1** MAINS POWER ON/OFF SWITCH
- 2** AC MAINS INPUT
(100-230V, 50/60Hz, 4A Max Power Bar)
- 3** SYNC IN
(Connects through IGUS chain to SYNC IN on head)
- 4** ETHERNET
(House Network)
- 5** ETHERNET
(Free Hole)
- 6** FREE HOLE
- 7** FREE HOLE

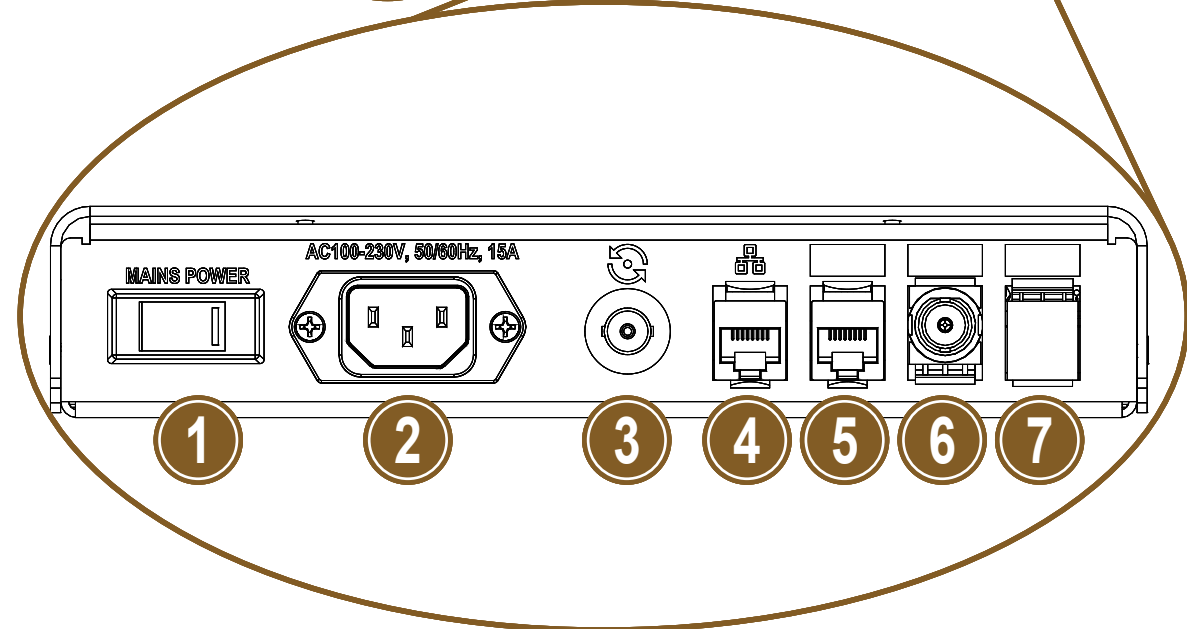
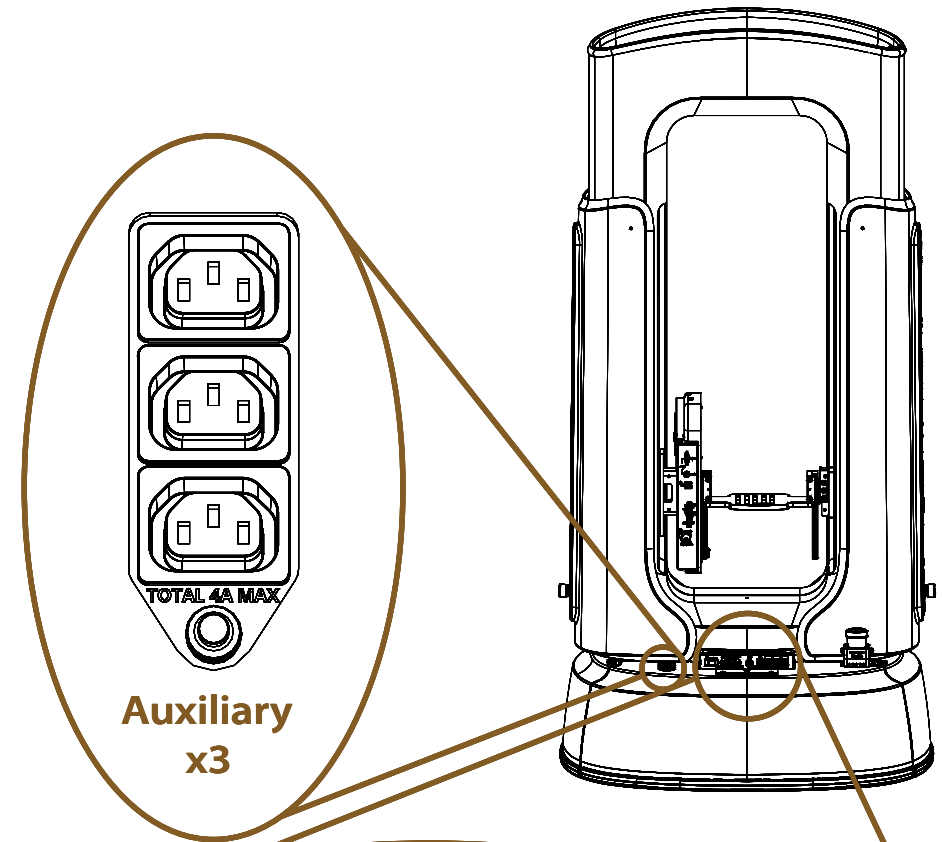

CONTROL SYSTEMS

SmartShell

SMARTSHELL CONTROL APPLICATION

The main interface for controlling Ross Video Artimo and Furio robots is SmartShell, an easy-to-use touch-screen interface that enables you to control camera systems automatically using stored presets, and manually using a CX Panel and/or buttons in the user interface.

The SmartShell computer comes with a touch screen monitor. You can also use the provided mouse and keyboard. For detailed information about SmartShell, refer to the SmartShell User Guide (5100DR-002-xx).



SmartShell Integration Requirements

Sync Format Compatibility

Artimo supports interlaced analog video reference signals such as NTSC (480i), PAL (576i), and interlaced Tri-Level sync video reference signals such as 720i and 1080i. Progressive formats are not supported.

Reserved Internal IP Address Range

Artimo's internal components, including lidar sensors, operate on the reserved subnet 192.168.108.x/24.

Do not assign IP addresses in this range to external equipment, SmartShell PCs, joystick panels, or tracking systems.

Doing so may cause IP conflicts or loss of communication.

CONTROL SYSTEMS

CX-3R Panel

CX-3R Panel Controls

The CX-3R Panel controls Artimo's pan, tilt, zoom, lift, XY, and iris functions with precision, supporting real-time adjustments and preset management.

For detailed setup instructions, refer to: the ***CX Panel Hardware Start Guide (4902DR-001-01)***.

The following image shows the CX-3R.

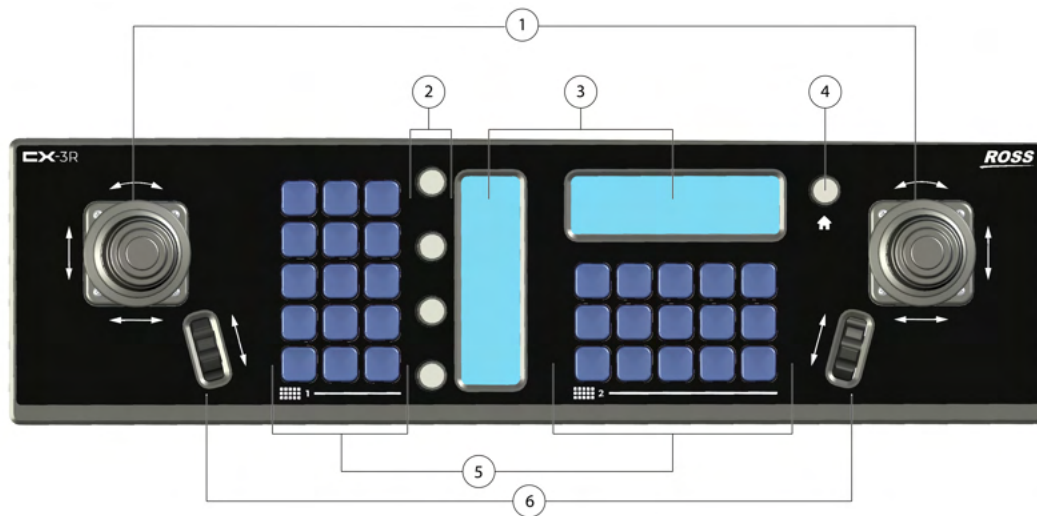

- 1 Joysticks**
Controls X and Y movement, lift height of the robotic pedestal, pan, tilt, and zoom.
- 2 Control Knobs**
Adjustments like iris settings in SmartShell to control lens brightness, or the execution time of a preset or movement.
- 3 Display Screens**
Used for network setup, panel connectivity status, and knob assignments and display of information during operation.
- 4 Home Knob**
Currently used as a button to switch between configuration mode and operation mode.
- 5 Button Panels**
Camera selection, preset and move execution, and other robotic commands (e.g., Cue, Cut, and Run).
- 6 Rollers**
Adjustments like image sharpness and duration of a move after execution.

Local Control



TOUCHSCREEN CONTROLS

Artimo's touchscreen interface enables local control of the system, allowing for manual robot movement along a single axis, including lift, pan, tilt, and drive functions, with additional lens control. The Artimo IP address and Furio firmware version are also displayed.

JOG - The jog controls on the touchscreen facilitate precise movements, enabling operators to position the camera system accurately.

Available controls include:

- **Select Axis:** Use the touchscreen to select the axis you wish to control (lift, pan, or drive).
- **Adjust Position:** Use the jog controls on the touch screen to make precise adjustments. Only one axis can be controlled at a time to ensure smooth and accurate movements.

NETWORK - The Network option allows for viewing and altering network settings, ensuring proper connectivity and integration with other systems.

SCREEN OFF - Turns off the display, which can be reactivated by touch.

TECHNICAL DETAILS

Specifications

General Specifications

Property	Value
Max. Net Payload	40 kg (88 lbs) Total, 32 kg (70.4 lbs) on Tilt Cradle
Optical Height (Floor to Tilt Axis)	Min: 70 cm, Max: 200 cm, Range: 130 cm
Max. System Height	258 cm
System Weight	< 180 kg
System Footprint	Max. Width: 94.0 cm with cowlings, 84.8 cm without

Environmental Specifications

Property	Value
Operating Temperature	0°C to +45°C
Humidity	0% to 90% RH, non-condensing
Storage Temperature	-30°C to +70°C (-22°F to +158°F)

Motion & Speed

Property	Value
Pan Axis Range	±200° (total 400°)
Tilt Axis Range	With Prompter: ±25° (50° total), Without Prompter: ±36.5° (73° total), Limited Range: ±85° (170° total)
Pan Speed	Min: 0.01°/sec, Max: 90°/sec
Tilt Speed	Min: 0.01°/sec, Max: 60°/sec
Floor Speed (XY Travel)	Min: 0.01 cm/sec, Max: 50 cm/sec
Lift Speed	Min: 0.01 cm/sec, Max: 15 cm/sec

Power Specifications

Property	Value
Total Input Power	100-230V AC, 50/60Hz, 15A
Auxiliary Output Power	100-230V AC, 50/60Hz, 4A Max Power Bar
Camera Output Power	12V DC, 6.25A Max

TECHNICAL DETAILS

Dimensions

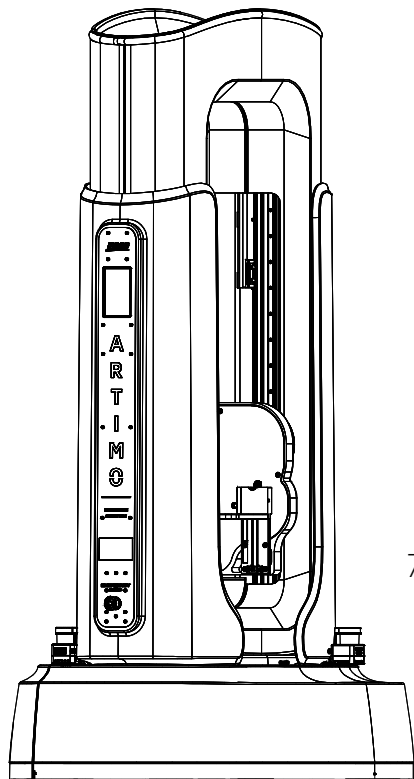

**Dynamic Lift
& Cradle Lowered**

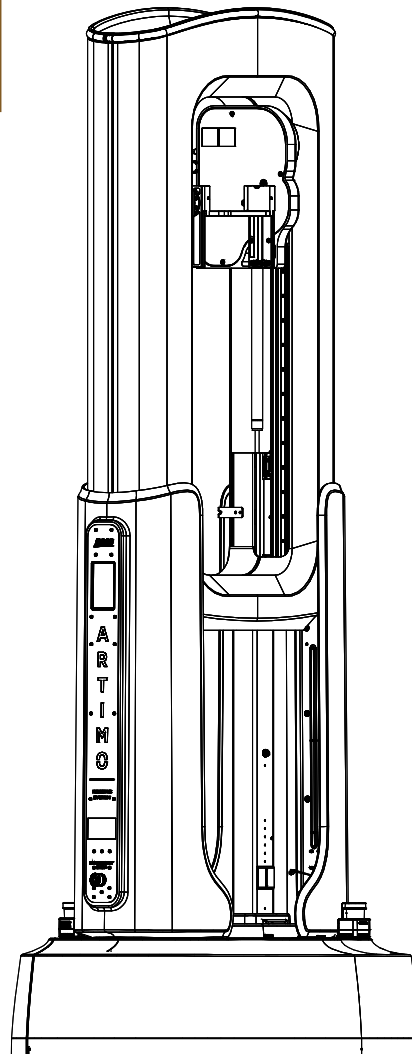

**Dynamic Lift
& Cradle Raised**

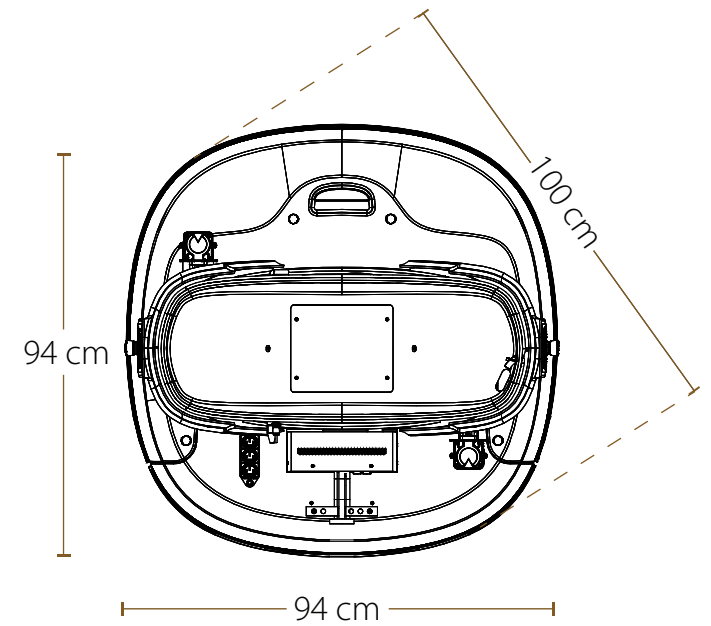

System Footprint

Site Requirements



The following documents provide information about site requirements for installing Artimo Systems and compatible control systems:

- **Artimo Site Requirements (5100DR-022-xx)**
Applies to all Artimo Systems.
- **Control Room Site Requirements for Standard Control Station (5100DR-021-xx)**
Applies to Ross Robotics systems that use a Standard SmartShell Control Station (RRB-CTL-3 or RRB-CTL-6).
- **Control Room Site Requirements for Standalone Control Station with Integrated Server (5100DR-032-xx)**
Applies to Ross Robotics systems that use a Standalone SmartShell Control Station with Integrated Server (RRB-CTL-3-SRV or RRB-CTL-6-SRV).

 **Caution:** It is recommended to get the final installation inspected by a structural engineer to make sure the building can support the system weight.

Navigation Systems

Lidar

Lidar in Artimo provides 360-degree scanning, enabling the creation of a detailed 3D map of the studio environment. This technology compares the current surroundings with stored maps to ensure precise navigation and static obstacle avoidance. For effective operation, it's crucial to keep the environment clear of temporary obstructions and ensure that key landmarks remain stable.

Creating a Room Map

Mapping is enabled via SmartShell, by moving Artimo around a room as the lidar system scans the environment, generating and saving a 3D map for precise future navigation.

Targeting

Targeting allows the robot to locate its position in the room by comparing lidar scans with a stored map. The (0,0) point in the studio is determined by the position of the wall marker used when the map was being created. It is essential that the marker is repositioned in the same spot if re-mapping of the studio is required, to preserve presets and moves.

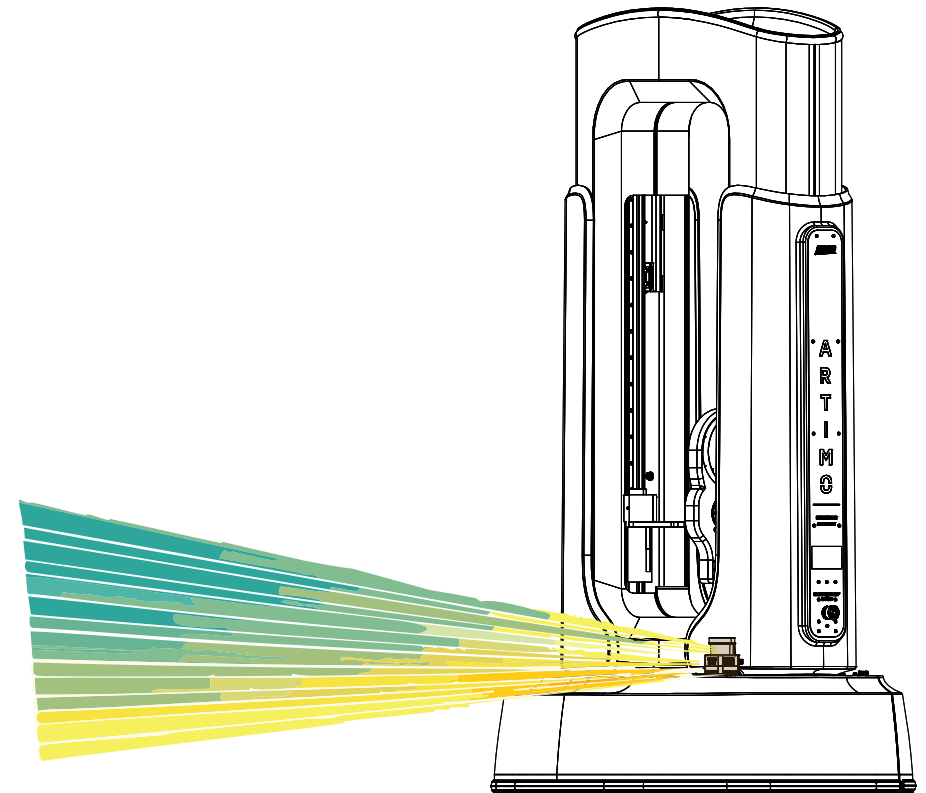

Laser beams are exaggerated for demonstration purposes.

Geofencing

Geofencing in SmartShell establishes virtual boundaries to restrict Artimo's movement to designated areas within the studio. This feature works in tandem with Artimo's navigation systems, using location data to enforce these boundaries. Geofencing helps ensure that Artimo operates within safe zones, preventing entry into restricted areas, and maintaining controlled, precise operation throughout its workspace.

General Inspection and Cleaning

Artimo requires light maintenance regularly. Periodically perform the following tasks:

- **Clean Artimo**

Turn off Artimo. Use a slightly water-dampened rag with mild liquid detergent to clean the pedestal and head. Avoid abrasive cleaners or solvents, and do not get connectors wet. Ensure the robot is completely dry before powering it on.

- **Inspect cables for damage**

Check the cable bundle for wear. If the sleeve is damaged, inspect the cables for exposed or damaged conductors. Replace any damaged components. Do not operate the robot with exposed conductors. Ensure all cable connections are secure and that cables are properly dressed with adequate slack.

- **Check mounting bolts**

Periodically ensure that all mounting bolts are tight, especially after initial installation.

- **Cable management and protection**

Ensure safe operation by incorporating a foam sleeve into the cable sock to prevent Artimo from rolling over cables. Include the sleeve in routine inspections as part of regular maintenance.

- **Inspect wheels for debris**

Visually inspect wheels for dirt and debris, which can affect smooth motion. If cleaning is needed, refer to the "Cleaning Artimo System Wheels" section.

- **Clean and inspect the Artimo marker**

Use a slightly water-dampened rag with mild liquid detergent to clean the marker.

- **Lidar sensor inspection**

Regularly inspect lidar sensors for damage and clean the surfaces to ensure accurate performance before operation. Exercise extreme caution, as even a minor lidar misalignment (such as 1°) can disrupt positioning.

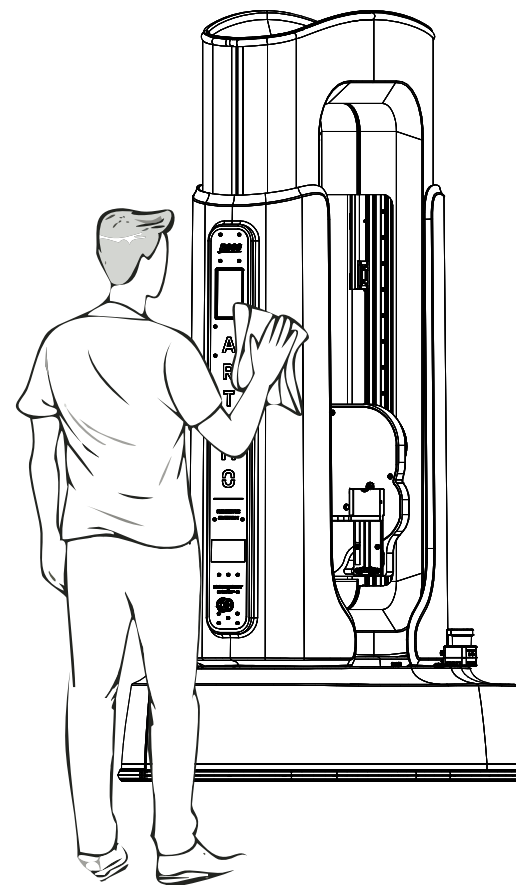

Marker Installation

The Artimo wall marker, a plastic sheet with markings, enables robotic pedestals to confirm their position with millimeter accuracy. While the lidar system can auto-target using room reference points if a map is stored, the marker helps align the system's 0,0 coordinates with geofencing and preset origins.

Alternatively, refer to the ***Floor Marker Stand Assembly Guide (5100DR-604-xx)*** if there is no suitable wall surface available.

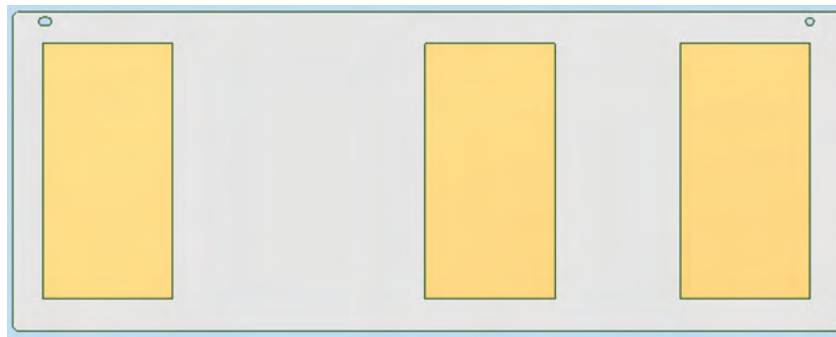

Installation Procedure

1. Select Location

Choose a spot on the studio wall with space around it for Artimo's movement. Avoid areas within the camera's view during live operation.

The chosen wall must be completely flat without curves.

2. Clean Marker Location

Ensure the wall is clean and dry before installation.

3. Position Marker

Ensure the center of the marker is approximately 350 mm from the ground.

4. Mark the Installation

Determine and mark the exact location where the drywall anchors should go before installing them. Ensure the marker will be perfectly level once installed.

5. Marker Installation

Install the drywall anchors in the marked locations. Hang the marker from the drywall anchors.

MAINTENANCE

Wheel Maintenance

As wheels move across the studio floor, they gather dirt and debris, requiring periodic cleaning to maintain smooth motion and accuracy.

Cleaning Procedure

1. Prepare Artimo

Move Artimo to a clean, spacious area away from obstacles and check the payload is balanced. Ensure that the system is in a safe state before proceeding: engage the E-Stop, power down the unit, and disable all axes. Verify that the castor axis and all other axes are free to turn.

2. Remove the Front Base Cowling

Remove the **four** thumb screws and lift off the cowling to expose the wheels. Disconnect the bumper connector.

3. Clean the Wheels

Wearing gloves, clean all wheels with a mild detergent. Check the castor assemblies for debris. Vacuum and wipe the base, then clean the surrounding floor.

Note: To access and clean the rear castors, rotate the pan stage 90 degrees.

4. Reassemble Artimo

Reconnect the bumper connector and reposition the cowling, align and secure the screw.

Note: If the bumper cable is not properly connected, or if the front cowling is not attached, an E-Stop condition will be in place.

Important: The use of a shielded Ethernet cable is required for conducted emissions regulatory compliance.

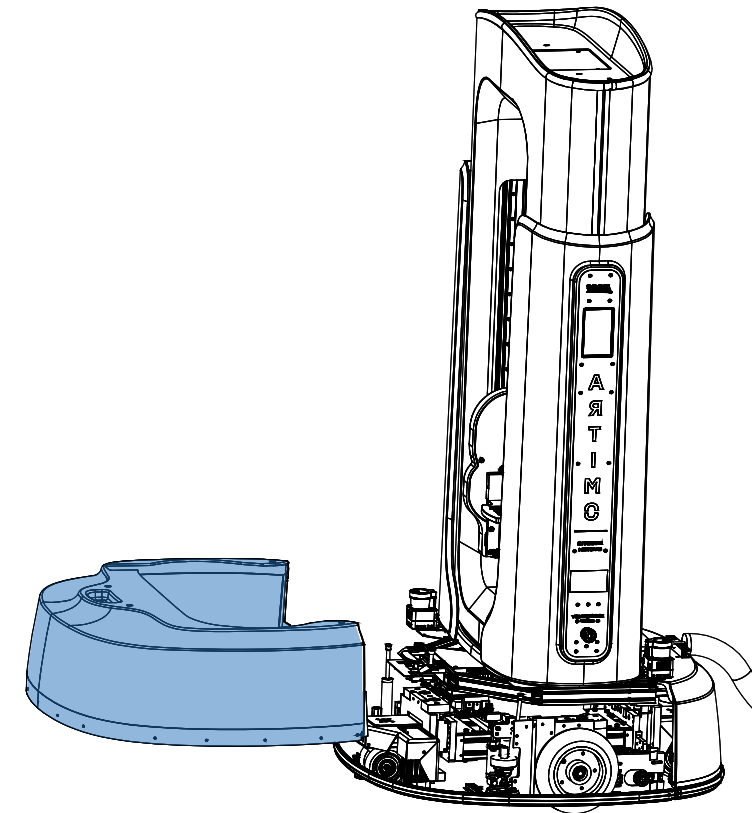
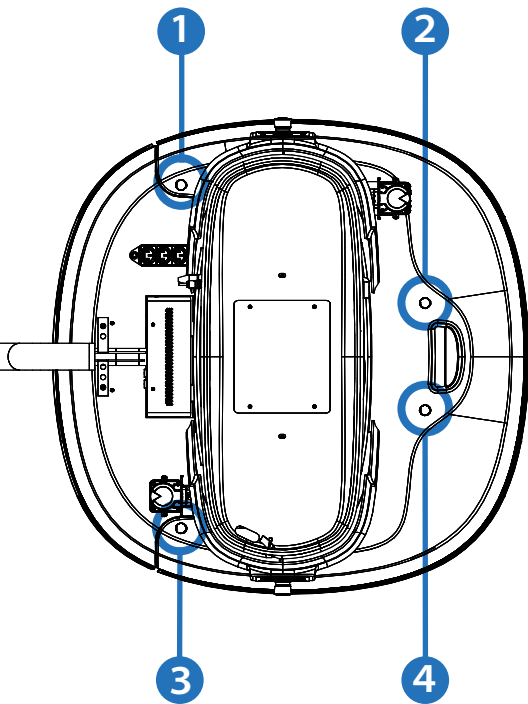

Handling & Operating

Best Practices

Operational Environment

Maintaining a Clean Space: Operate Artimo in a clean environment to ensure optimal performance and reduce the risk of obstructions or hazards that could affect movement or stability.

Restricting Area Access: Ensure that the operating environment is limited to trained professionals. This environment should be free of children, pets, and any unqualified personnel, minimizing the risk of accidental injury or interference with the system's operation.

Before powering up, position PAN and cabling as follows: With Artimo powered off, verify cabling is uncoiled around the base. If coiled, rotate PAN by hand to unwrap cabling. Ensure PAN points towards studio 0. Power up Artimo. Launch SmartShell application, select Artimo, select OPERATE, select TARGET. Allow the Artimo to position itself in the room. Select PAN axis. Verify position of PAN axis is accurate.

Tilt Lock and Rotation: To control the tilt axis movement by locking and unlocking, use a 4 mm hexagonal wrench. To control the tilt axis rotation range, use a 5 mm hexagonal wrench as shown.

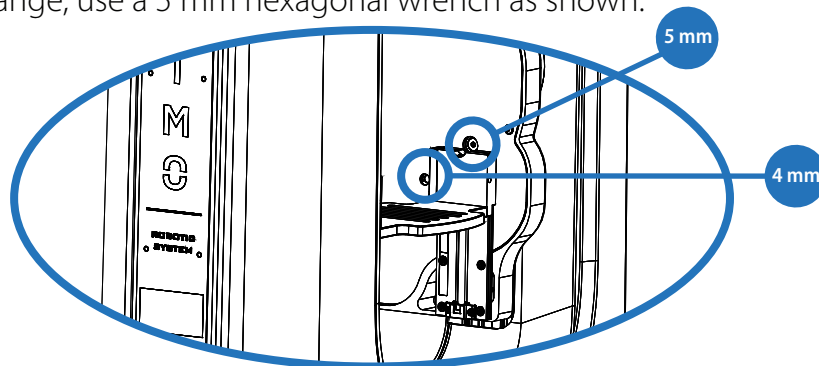

Safe Handling Techniques

Moving Artimo: To move Artimo unpowered, remove the front cowling, align the castor wheels and attach the tethers to the metal loops of the castors, as shown.

Note: There are two castors, one on either side of the lift, beneath the front cowling.

When pulling, apply even force to prevent tipping. Two people should move Artimo; one pulls the tether, while the other maintains stability of the lift. Avoid sudden stops or changes in direction to ensure steady movement.

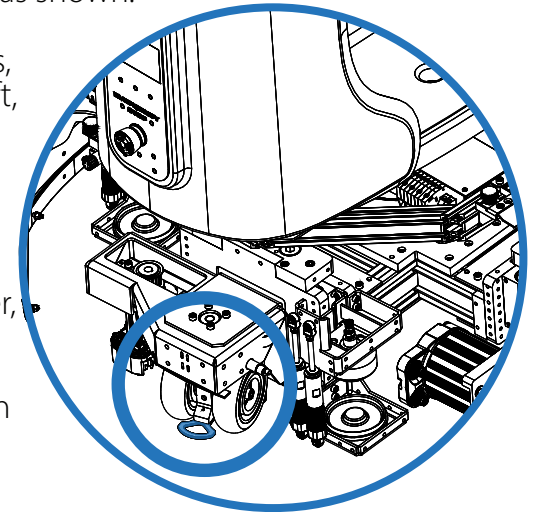

Lifting and Handling Payloads: Always lift from designated points, using your legs to prevent strain. Lock the tilt before adjusting the payload. Ensure the payload is balanced or removed to avoid instability and potential injury. Maintain a straight back and lift with your legs. Never operate the unit with the payload removed.

SAFETY

Handling & Operating

OPERATIONAL DISTANCE

Maintain a distance of 2 m from Artimo when it's running presets.

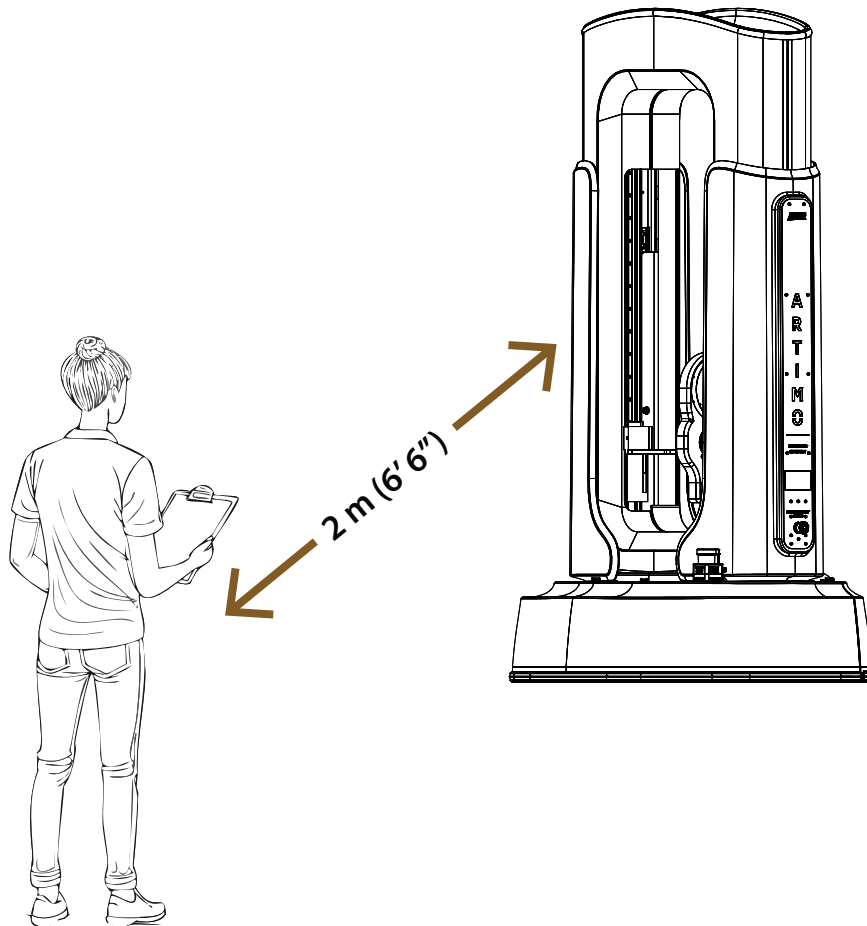

PINCH & CRUSH POINTS

Pinch and crush points in an Artimo system are located where the static and dynamic lift mechanisms move, particularly between the lift column and payload, creating potential hazards if hands or objects are near these moving parts during operation.

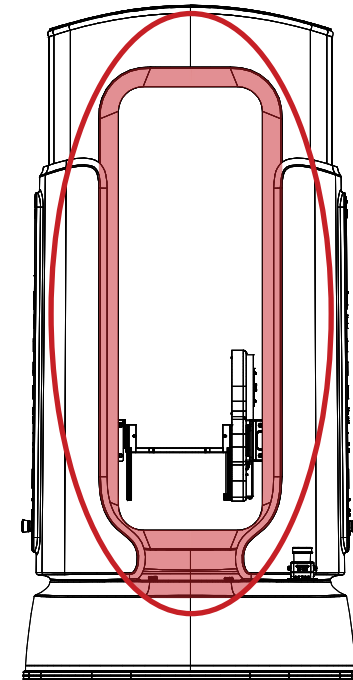

Emergency Stop

Overview

Two emergency stops (e-stops) are critical safety devices located on either side of Artimo that immediately halt all system operations in the event of an emergency.

Resetting

After pressing an e-stop, the system requires a reset.

E-stops are rotational and must be rotated anti-clockwise for release. Before resuming operations, perform safety checks to ensure the issue that triggered the e-stop is resolved.

Scenarios for Use

E-stops should be used in situations such as mechanical malfunctions, obstacles in the path, or any immediate safety threat. Engage the e-stop whenever the system is powered on during setup, troubleshooting, servicing, or when working within the recommended safety distance.

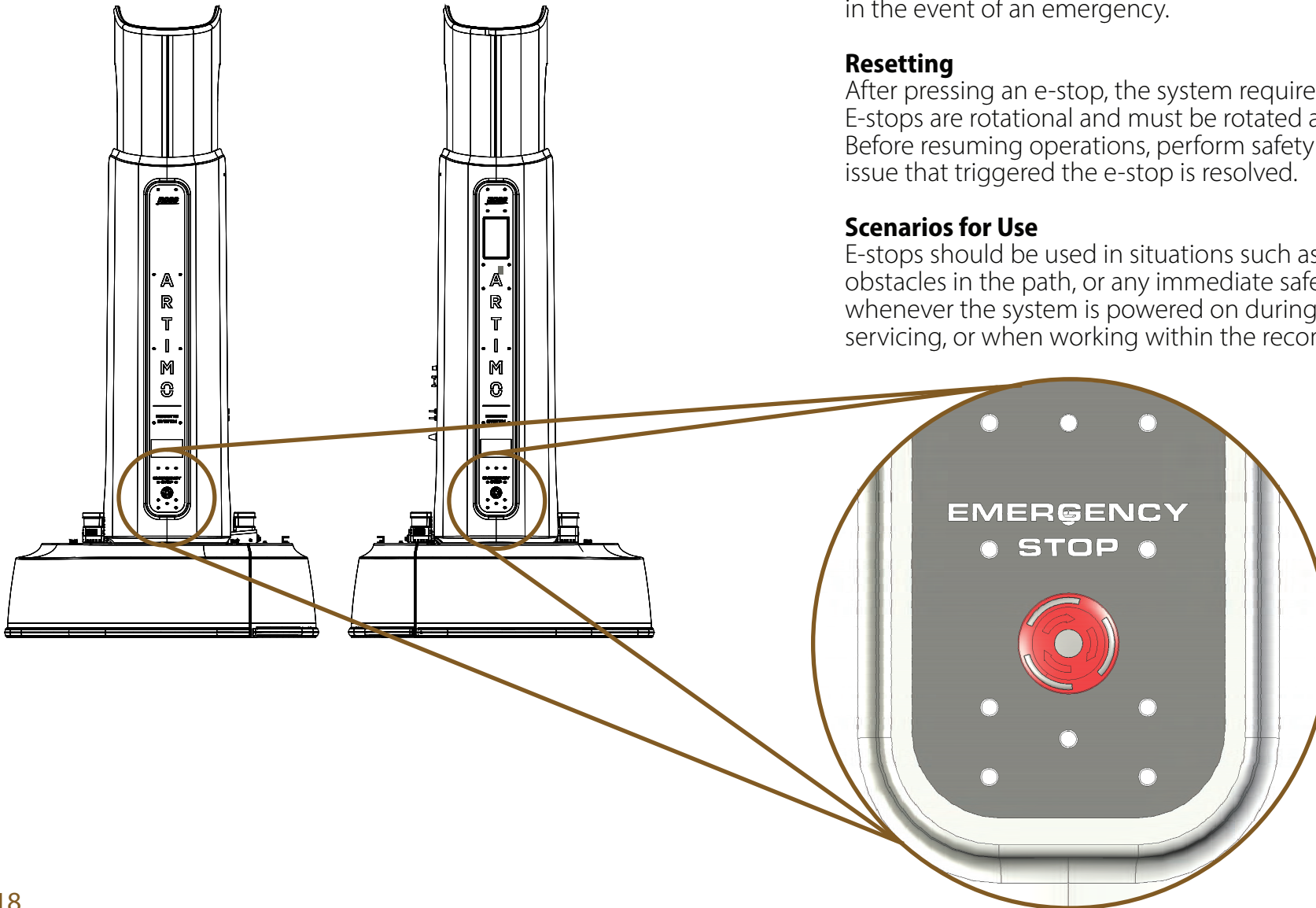

Safety Features

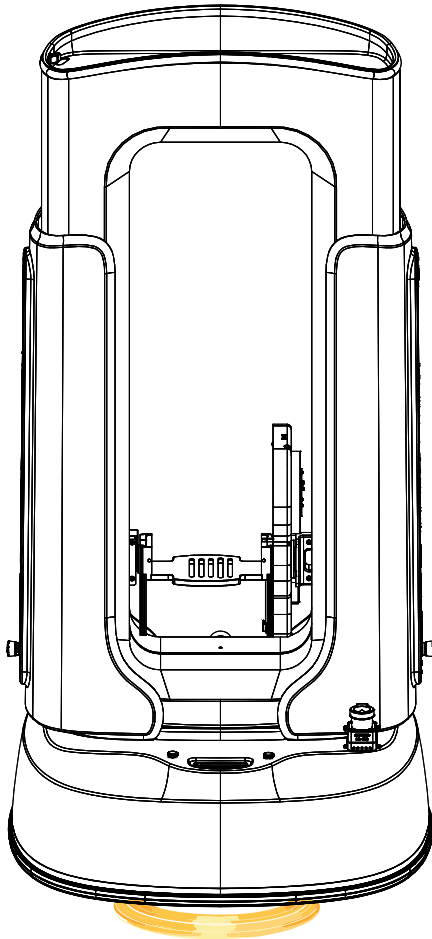

Emergency Stops (E-Stops) x2

Located on each side of the lift column, these stops immediately halt all system movements in an emergency.

360° LED Lights

Motion LED lights at the bottom of the dolly and tally lights at the top of the lift column provide visual status indicators, using color coding to signal the system's state.

Color indicators include:

- **Amber:** Indicates forward motion.
- **Blue:** Indicates the trailing side during forward motion.

360° Pressure Bumpers

Upon detecting an impact of 11 N or more, these bumpers stop the robot, cancel any active movement, and remove joystick control. Follow-up actions are detailed in the *SmartShell User Guide*.

LiDAR Sensors x2

Provide 360-degree scanning for Geofencing to avoid collisions with known static obstacles.

Remote E-Stop

Available at the operator's workstation for immediate system shutdown from a distance. The E-Stop latches and must be turned to release. Reconnecting via SmartShell or automation triggers a homing sequence and the unit may move after release.







Safety Interlock & Tilt Lock Pins



Secure the lift in place for stability during maintenance or emergencies.

Important Safety Instructions

ROBOTICS SAFETY MEASURES

Impact/Collision Risk management & reduction

-  1. **Warning:** This equipment must be operated by trained personnel only. This equipment must be operated in a controlled and restricted-access environment only.
-  2. **Warning:** This system must only be used by operators with extensive prior knowledge of remote-controlled systems, they must have undergone special training approved by Ross Video Ltd.
-  3. **Warning:** The operator must have control of all people, objects, and structures in the immediate vicinity of the system when using it. A safety clearance distance of at least 2 m is recommended from the maximum extension point of the system in any direction.
-  4. **Warning:** The operator must have carried out an appropriate risk assessment before using the system and be satisfied that all operations can be carried out safely.
-  5. **Caution:** It is recommended to get the final installation inspected by a structural engineer to make sure the building can support the system weight.
-  6. **Caution:** System can tip over if not fully disassemble before transportation.
-  7. **Caution:** Imbalanced payloads may cause equipment damage and may present a tipping hazard. Ensure payloads are properly balanced. If you adjust a payload, always rebalance it.

-  8. **Caution:** Loose payloads may slip, causing equipment damage and injury. Periodically check all bolts that fasten the payload, to ensure that they are tightened to specified torque. If the payload is loose or slips, ensure that it is properly balanced and fastened before operating the robot.
-  9. **Caution:** Risk of impact due to freewheeling head. Keep a safe distance and control of the head during payload setup

Additional Robot Safety Notices

-  10. **Caution:** Serious injuries can result from people tripping over equipment, such as cables.















Methods of reducing such risks include, but are not limited to, the following:

- Inspect and remove restraints on cables regularly so they do not present a tripping hazard.
- Erecting signs at studio entrances to remind people about tripping hazards and other studio hazards.
- Training personnel in safety procedures and proper cable management techniques.
- Showing personnel and guests the locations of cables equipment and explaining that robotic cameras and cables attached to them may move at any time.
- Escorting guests at all times while in the studio.
- Ensuring adequate lighting when working in the studio.
- Marking safe paths and/or restricted areas, to keep people away from moving robots and potential tripping hazards.

SAFETY

Important Safety Instructions

Additional Robot Safety Notices

-  11. Important: Ensure that proper cable management techniques are always used:
- Bundle and wrap cables neatly and provide adequate strain relief and slack where necessary.
 - Test your cable installation by slowly moving the robotic units through their entire range of motion and observing the cables, to ensure that they do not become taut, or snag on anything.
 - Avoid running cables along floors in places where they may present a tripping hazard.
 - Clearly mark areas where cables may present a tripping hazard and keep personnel away from such areas.
 - Inspect cables periodically for damage, and to ensure that proper cable management is maintained.
-   12. Important: Safety Shoes must be worn while working on or near the system (Installation, Setup, Troubleshooting, Servicing, Operation).
-  13. Important: Only qualified and trained servicing personnel are allowed to remove covers and access internal system areas.
-  14. Warning: E-Stop button must be engaged if the system is ON, and performing setup, troubleshooting, servicing, or any other task within the recommended safety distance.
-  15. Warning: System must be powered OFF when servicing motors, belts, high voltage circuits and installing or adjusting the payload.
-   16. Warning: Keep all personnel away from the system when operational.
-  17. Important: When servicing or moving equipment, always observe safe handling practices. Get help to move heavy items. Use safe lifting techniques. Follow all safety rules of your workplace.
-  18. Important: Loose or overtightened bolts may cause equipment damage. When servicing, tighten bolts to specified torque.
-  19. Warning: DO NOT perform maintenance or adjustments without proper precautions, training and without following proper procedures. Lift Gas Struts store potential energy. Uncontrolled release can cause serious injury or damage.
-  20. Warning: DO NOT perform maintenance or adjustments without proper precautions, training and without following proper procedures. Springs in suspension system store potential energy. Uncontrolled release can cause serious injury or damage. Lift, Head and payload must be removed from the system before performing suspension maintenance.
-  21. Warning: The suspension system contains a non-toxic oil. An accidental release of this oil can cause a particular danger of slipping. Follow the safety precautions below in the event of a leak:
-  • Wear protective impermeable gloves to handle contents of damaged or leaking units.
 - Wear safety glasses
 - Do not step on the spilled oil
 - After eye contact: Rinse opened eye for several minutes under running water. Remove contact lenses if worn. Seek medical treatment in case of complaints.
 - After skin contact: Immediately wash with water and soap and rinse thoroughly. If skin irritation is experienced, consult a doctor.

Important Safety Instructions

LASER SAFETY MEASURES

Laser product safety (LIDAR)

22. Before using this product and any associated equipment, refer to the sections below to avoid personnel injury and to prevent product damage. For further safety information when using laser products, consult the following publications:

- IEC 60825-1:2014, Safety of Laser Products - Part 1: Equipment classification and requirements (for use outside of the U.S.A.)
- ANSI Z136.1, Safe Use of Lasers (for use in the U.S.A.)

Products may require specific equipment, and /or installation procedures be carried out to satisfy certain regulatory compliance requirements.



NOTICE — CLASS 1 LASER PRODUCT IEC 60825-1:2014



CAUTION — INVISIBLE LASER RADIATION WHEN OPEN. AVOID EXPOSURE TO THE BEAM



23. **Warning:** Do not open or disassemble the housing/cover of the LIDAR sensor. Opening the housing will not switch off the laser can lead to dangerous exposure to radiation.

24. During normal operation of this product, heed the following safety measures:

- Do not stare at, or into, broken, or damaged, Lidar sensor cover.
- Do not remove the Lidar sensor cover.
- Only properly trained and authorized personnel shall be permitted to operate laser products.
- Ensure that appropriate labels are displayed in plain view and in close proximity to the optical port on the protective housing/access panel of the terminal equipment.



Notice — Before operating or servicing this product, all personnel should be familiar with laser safety.

25. Lidar sensor is not intended to be customer-serviced and should be returned to the factory for replacement.



Warning — Do not use optical equipment, such as a microscope or an eye loupe, to stare at the energized fiber end. Doing so may damage your eyes.

Important Safety Instructions

GENERAL SAFETY INSTRUCTIONS



26. **Warning:** Read these instructions.

27. Keep to these instructions.

28. Heed all warnings.

29. Follow all instructions.

30. Do not use this apparatus near water.

31. Clean only with a dry cloth.

32. Do not block any ventilation openings.
Install in accordance with manufacturer's instructions.

33. Do not install near heat sources such as radiators, heat registers, stoves, or other apparatus (including amplifiers) that produce heat.

34. Do not defeat the safety purpose of the polarized or grounding-type plug. A polarized plug has two blades with one wider than the other. A grounding type plug has two blades and a third grounding prong. The third prong is provided for your safety. If the provided plug does not fit into your outlet, consult an electrician for replacement of the obsolete outlet.

35. Protect the power cord from being walked on or pinched, particularly at plugs, convenience receptacles, and the point where they exit from the apparatus

36. Only use attachments/accessories specified by the manufacturer.

37. Unplug this apparatus during lightning storms or when unused for long periods of time.

38. Refer all servicing to qualified service personnel. Servicing is required when the apparatus has been damaged in any way, such as when the power-supply cord or plug is damaged, liquid has been spilled or objects have fallen into the apparatus, the apparatus has been exposed to rain or moisture, does not operate normally, or has been dropped.

39. Do not expose this apparatus to dripping or splashing, and ensure that no objects filled with liquids, such as vases, are placed on the apparatus.

40. To completely disconnect this apparatus from the AC Mains, disconnect the power supply cord plug from the AC receptacle.

41. The mains plug of the power supply cord shall remain readily operable.



42. **Warning:** Indoor Use Only: To reduce the risk of fire or electric shock, do not expose this apparatus to rain or moisture.





43. The safe operation of this product requires that a protective earth connection be provided. A grounding conductor in the equipment's supply cord provides this protective earth. To reduce the risk of electrical shock to the operator and service personnel, this ground conductor must be connected to an earthed ground.



44. **Warning:** This equipment is not suitable for use in locations where children are likely to be present.

Important Safety Instructions

GENERAL SAFETY INSTRUCTIONS

-  45. **Warning:** This apparatus, when equipped with multiple power supplies, can generate high leakage currents. To reduce the risk of electric shock, ensure that each individual supply cord is connected to its own separate branch circuit with an earth connection.
-  46. **CAUTION:** These service instructions are for use by qualified service personnel only. To reduce the risk of injury, do not perform any servicing other than that contained in the operating instructions unless you are qualified to do so.
47. Service barriers within this product are intended to protect the operator and service personnel from hazardous voltages and moving parts. For continued safety, replace all barriers after servicing.
48. Certain parts of this equipment still present a safety hazard with the power switch in the OFF position. To avoid electrical shock, disconnect all A/C power cords from the chassis' rear appliance connectors before servicing.
49. This product contains safety critical parts, which, if incorrectly replaced, may present a risk of fire or electrical shock. Components contained within the product's power supplies and power supply area are not intended to be customer-serviced and should be returned to the factory for repair.
50. To reduce the risk of fire, replacement fuses must be the same type and rating.
51. Use only power cords specified for this product and certified for the country of use.
52. The safe operation of this equipment requires that the user heed and adhere to all installation and servicing instructions contained within the equipment's Setup Manuals.
-  53. **Warning:** This product includes "Ethernet Ports " which allow this product to be connected to local area networks (LAN). Only connect to networks that remain inside the building. Do not connect to networks that go outside the building
-  54. **CAUTION:** This apparatus contains a Lithium battery, which if replaced incorrectly, or with an incorrect type, may cause an explosion. Replace only with a CR2032 coin type lithium battery. Dispose of used batteries according to the manufacturer's instruction by qualified service personnel.
55. For use at an altitude of 2000m or lower.
56. For use in non-tropical locations.
-  57. **CAUTION:** Do not make mechanical or electrical modifications to the equipment or add metallic items, such as metallic foil labels, to the printed circuit boards. Modifications can impair regulatory compliance, or performance and may void your warranty.

SAFETY

Important Safety Instructions

EMC NOTICES

United States of America — FCC Part 15

This equipment has been tested and found to comply with the limits for a class A Digital device, pursuant to part 15 of the FCC Rules. These limits are designed to provide reasonable protection against harmful interference when the equipment is operated in a commercial environment. This equipment generates, uses, and can radiate radio frequency energy and, if not installed and used in accordance with the instruction manual, may cause harmful interference to radio communications. Operation of this equipment in a residential area is likely to cause harmful interference in which case the user will be required to correct the interference at his own expense.

 **Important:** Changes or modifications to this equipment not approved by Ross Video Limited could void the user's authority to operate this equipment.

Canada

This Class " A " digital apparatus complies with Canadian ICES-003. Cet appareil numérique de la classe " A " est conforme a la norme du Canada.

Europe

This equipment is in compliance with the essential requirements and other relevant provisions of **CE Directive 93/68/EEC**.

Korea - Class A Statement

이 기기는 업무용 환경에서 사용할 목적으로 적합성 평가를 받은 가정용 환경에서 사용하는 경우 전파간섭의 우려가 있습니다. This device has been evaluated for conformity for use in a business environment. When used in a home environment, there is a danger of interference.

Korea - Class A Statement

The following is the Korean Class A Broadcasting and Telecommunication Products for Business Purpose Statement.

이 기기는 업무용(A급) 전자파적합기기로서 판매자 또는 사용자는 이 점을 주의하시기 바라며, 가정외의 지역에서 사용하는 것을 목적으로 합니다.

International

This equipment has been tested to **CISPR32:2015** along with amendment **AMD1:2019** and found to comply with the limits for a Class A Digital device.

 **Important:** This is a Class A product. In domestic environments, this product may cause radio interference, in which case the user may have to take adequate measures.

Important Safety Instructions

ENVIRONMENTAL INFORMATION

Waste Electrical and Electronic Equipment Directive (WEEE Directive)

The equipment that you purchased required the extraction and use of natural resources for its production. It may contain hazardous substances that could impact health and the environment.

To avoid the potential release of those substances into the environment and to diminish the need for the extraction of natural resources, Ross Video encourages you to use the appropriate take-back systems. These systems will reuse or recycle most of the materials from your end-of-life equipment in an environmentally friendly and health-conscious manner.

The crossed-out wheeled bin symbol invites you to use these systems.



If you need more information on the collection, reuse, and recycling systems, please contact your local or regional waste administration. You can also contact Ross Video for more information on the environmental performances of our products.

Use of Hazardous Substances in Electrical and Electronic Products (China RoHS)

Ross Video Limited has reviewed all components and processes for compliance to: "Management Methods for the Restriction of the Use of Hazardous Substances in Electrical and Electronic Products" also known as China RoHS. The "Environmentally Friendly Use Period" (EFUP) and Hazardous Substance Tables have been established for all products. We are currently updating all of our Product Manuals.

The Hazardous substances tables are available on our website at: <http://www.rossvideo.com/about-ross/company-profile/green-practices/china-rohs.html>

电器电子产品中有毒物质的使用

Ross Video Limited 按照以下的标准对所有组件和流程进行了审查：

"电器电子产品有害物质限制使用管理办法" 也被称为中国RoHS。

所有产品都具有"环保使用期限"(EFUP)和有害物质表。目前，我们正在更新我们所有的产品手册。

有害物质表在我们的网站：

<http://www.rossvideo.com/about-ross/company-profile/green-practices/china-rohs.html>

Contact

GENERAL INFORMATION

General Business Office: (+1) 613 • 652 • 4886

Fax: (+1) 613 • 652 • 4425

E-mail for General Information: solutions@rossvideo.com

Ross Video Website: <http://www.rossvideo.com>

ADDRESS

Ross Video Limited
8 John Street
Iroquois, Ontario
Canada, K0E 1K0

Ross Video Incorporated
P.O. Box 880
Ogdensburg, New York
USA 13669-0880

TECHNICAL SUPPORT

Toll Free Technical Support: 1-844-652-0645 (North America)
+800 1005 0100 (International)

Technical Support: (+1) 613 • 652 • 4886

E-mail for Technical Support: techsupport@rossvideo.com

ROSS VIDEO HELP CENTER: <https://support.rossvideo.com/hc/en-us>

Technical Manual

TECHNICAL MANUAL FOR ARTIMO

- Ross Part Number: 5100DR-600-02
- Publication Date: May 31, 2025.
- Published in Canada.

PATENTS

Ross Video products are protected by patent numbers US 7,034,886; US 7,508,455; US 7,602,446; US 7,802,802 B2; US 7,834,886; US 7,914,332; US 8,307,284; US 8,407,374 B2; US 8,499,019 B2; US 8,519,949 B2; US 8,743,292 B2; GB 2,419,119 B; GB 2,447,380 B. Other patents pending.

COPYRIGHT

©2025 Ross Video Limited, Ross®, and any related marks are trademarks or registered trademarks of Ross Video Limited. All other trademarks are the property of their respective companies. PATENTS ISSUED and PENDING. All rights reserved. No part of this publication may be reproduced, stored in a retrieval system, or transmitted in any form or by any means, mechanical, photocopying, recording or otherwise, without the prior written permission of Ross Video. While every precaution has been taken in the preparation of this document, Ross Video assumes no responsibility for errors or omissions. Neither is any liability assumed for damages resulting from the use of the information contained herein.

ROSS[®]

