

Ports and Pinouts

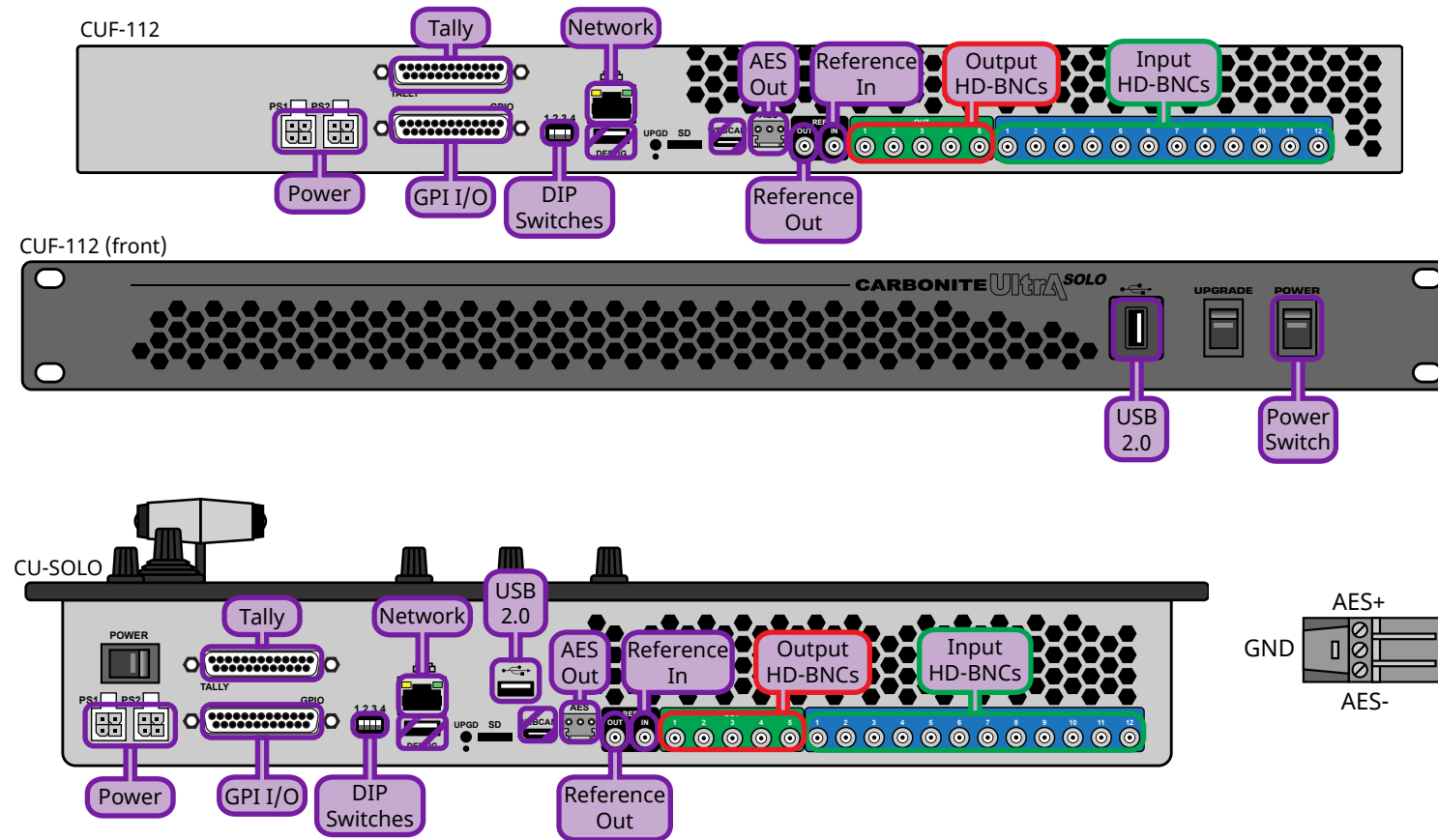

Not Used at this time.

Tally
(female DB25)

Pin	Tally	Pin	Tally
1	1	14	14
2	2	15	15
3	3	16	16
4	4	17	17
5	5	18	18
6	6	19	19
7	7	20	20
8	8	21	21
9	9	22	22
10	10	23	23
11	11	24	24
12	12	25	Common
13	13		

GPI I/O
(female DB25)

Pin	GPI	Pin	Signal
1	I/O 1	14	I/O 14
2	I/O 2	15	I/O 15
3	I/O 3	16	I/O 16
4	I/O 4	17	I/O 17
5	I/O 5	18	I/O 18
6	I/O 6	19	I/O 19
7	I/O 7	20	I/O 20
8	I/O 8	21	I/O 21
9	I/O 9	22	I/O 22
10	I/O 10	23	I/O 23
11	I/O 11	24	I/O 24
12	I/O 12	25	Ground
13	I/O 13		

Control Cabling

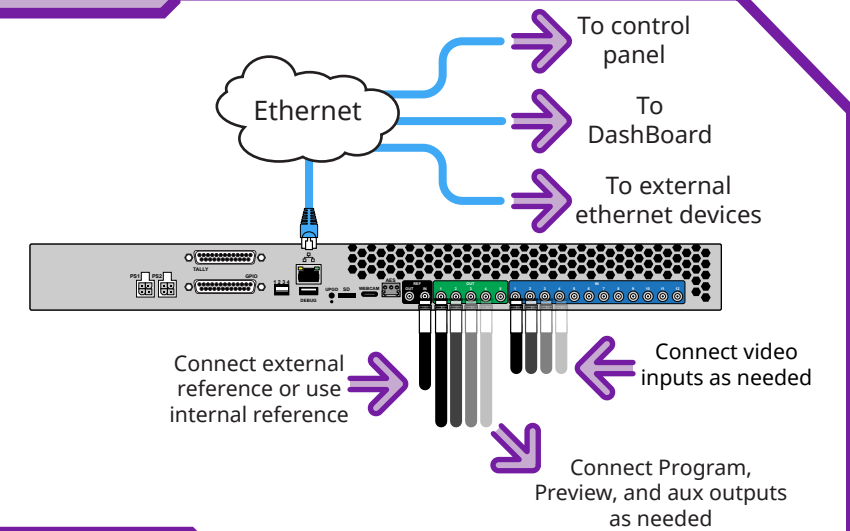

Power Cabling

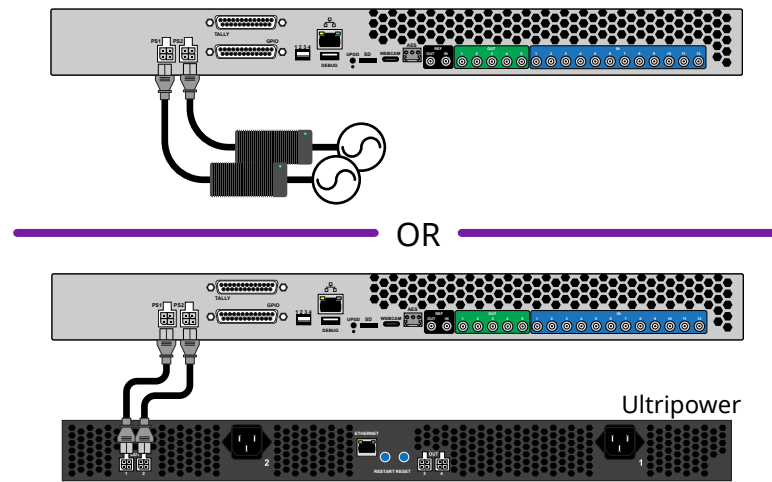

Notes:

- The DEBUG USB port below the Network port is for debug purposes only and cannot be used with a USB drive.
- The WEBCAM port is not supported at this time.
- The MultiViewer can be assigned to any output.
- Audio is not embedded in the MultiViewer output.

Specifications

SDI Input Formats	Default Values	Max Power Consumption	Video Input Specifications	Video Output Specifications	AES Output Specifications
720p 50/59.94Hz	Frame IP 192.168.0.123	CU-SOLO 100W, 6.67A, 15V	Equalization >40m @ 12Gb/s	Return Loss < -7.8dB @ 12Gb/s	Audio Depth 24-bit in HD
1080i 50/59.94Hz	FTP User name user	CUF-112 90W, 6A, 15V	(using Belden 1694 cable) >100m @ 1.5 Gb/s	< -10dB @ 3Gb/s	Channels 1 Stereo Pair
1080pSF 23.98/24/25/29.97Hz	FTP Password password		>300m @ 270 Mb/s (5°-40°C)	< -15dB @ 1.5Gb/s	File Format Multi-Channel
1080p 23.98/24/25/30/29.97/30/50 (A)/59.94 (A)/60Hz			Impedance 75 ohm, terminating	Rise and Fall Time 27ps +/- 10% (UHD)	Waveform Audio File
UHDTV1 23.98/24/25/29.97/30/50/59.94/60 (12Gb/s)			Video Inputs SMPTE 259M/292M serial digital (non-looping)	240ps +/- 10% (HD)	Impedance 110 Ohms, differential
			Reference Inputs Standard Definition — analog black (non-terminating, looping)	800ps +/- 10% (SD)	Min/Max Output Voltage 1.5/6V peak-to-peak
				Signal Level 800mV +/- 10%	Swing
				DC Offset 0 Volts	Rise and Fall Times 20ns (typical)
				Overshoot < 10%	Sample Rate 48kHz
				SDI HD Mode 10-bit SMPTE-292M/424M	Synchronization Locked to Video
				SDI UHD Mode SMPTE ST 2082-1:2015 (1:2016)	

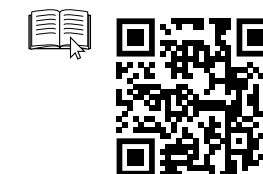

CAUTION: Before you set up and operate your switcher, see the "Important Safety Instructions" in your Setup manual.

CU-SOLO Rack Mounting

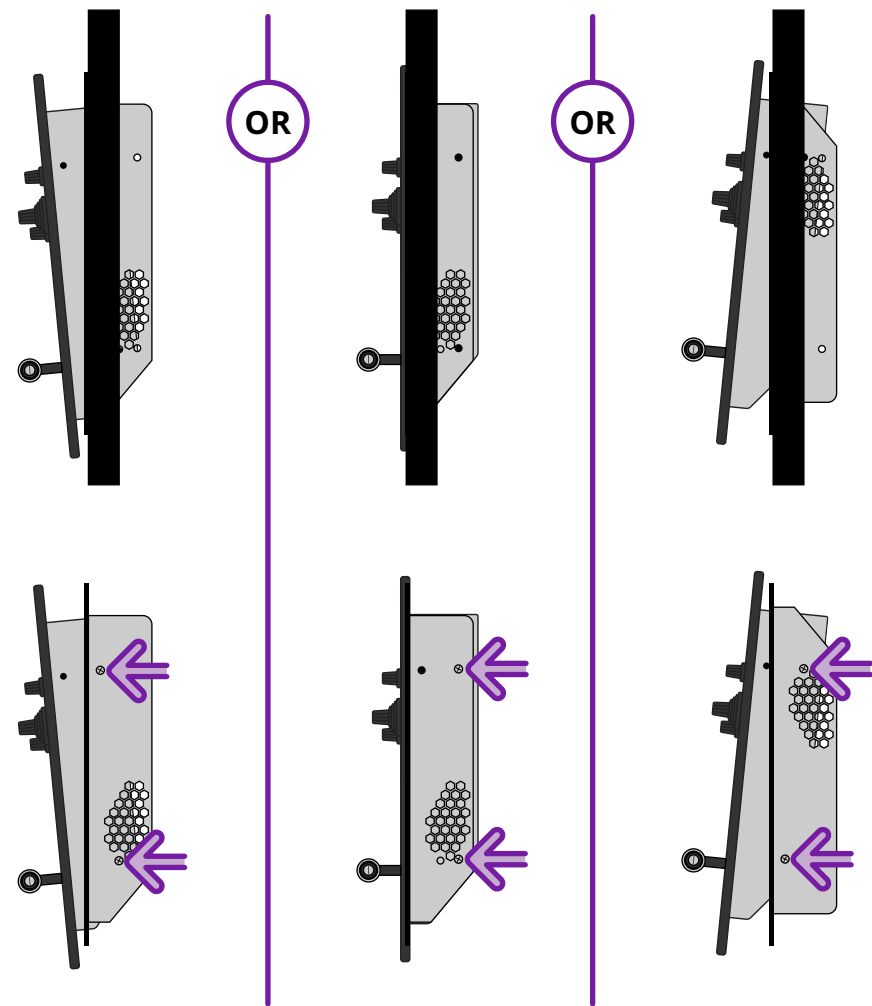

CU-SOLO Desk Mounting

Note: Panel dimensions and CAD drawings are available from the Ross Video website or from Technical Support.

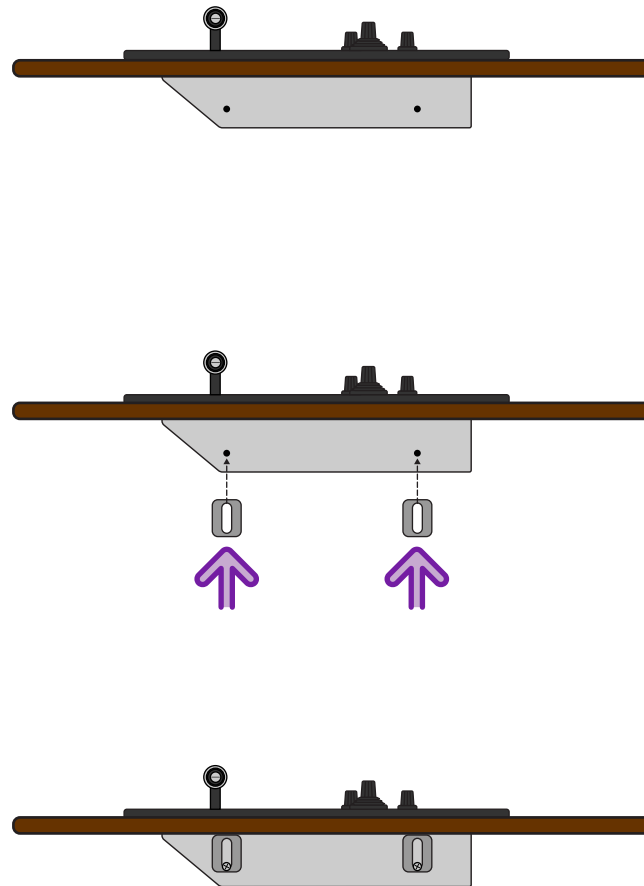

1RU Audio Breakout Module (ABM)

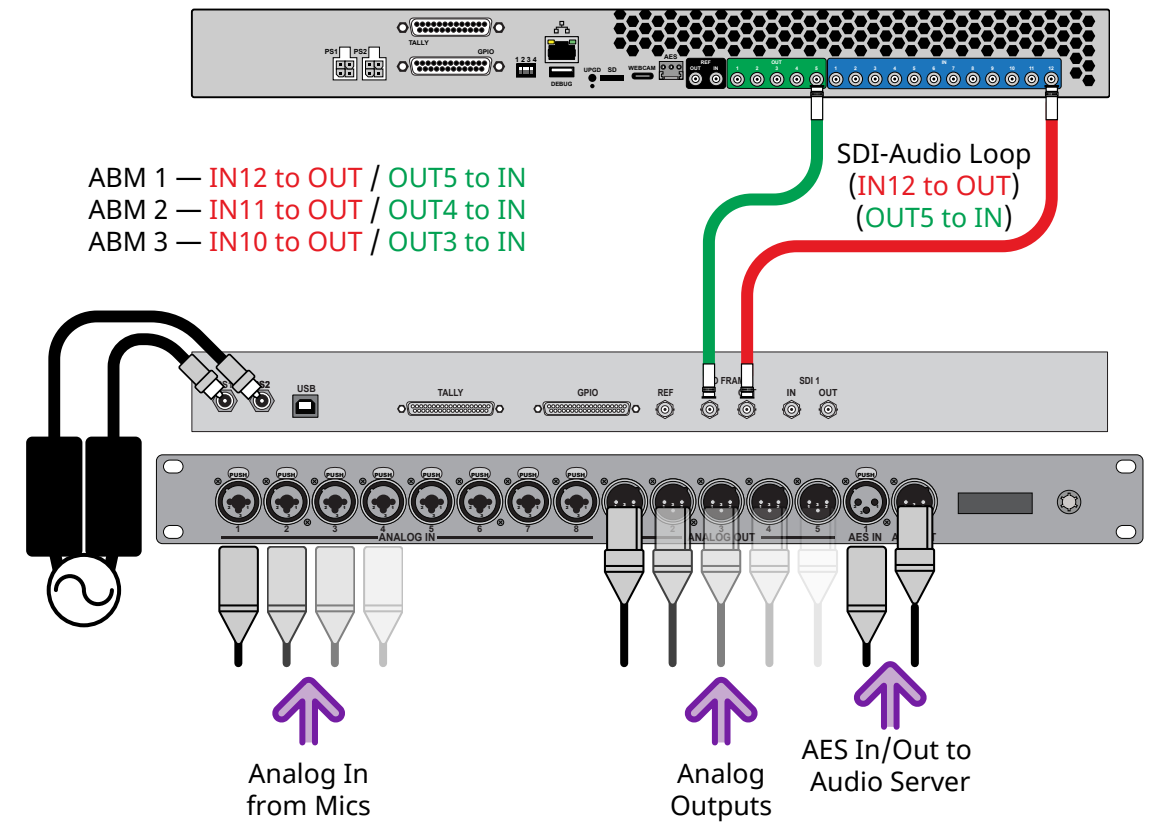

Important: Ensure that Phantom Power is turned off for the Analog Input unless you are connecting a microphone that requires phantom power. Connecting the line out from an audio device to the analog input with phantom power on could damage the audio device and/or the 1RU Audio Breakout Module. For added safety, a TRS phone connector should be used for line in audio sources.

Note: It is recommended that you always connect the AC Power Adapter to the device before connecting to Mains Power.

Analog Audio Input Specifications	
Input Impedance	XLR: 2K ohm ¼" Jack: 10K ohm
Maximum Level	+24dBu
Frequency Response	±0.3dB (22Hz to 20kHz @ Fs = 48kHz)
Signal to Noise Ratio	-95dB
"A" weighting	-98dB
CCITT weighting	-107dB
THD	>93dB or <0.002%
Amplitude Linearity	<0.8dB @ -100dBFS
Crosstalk	-94dB

Analog Audio Output Specifications	
Maximum Level	+24dBu
Frequency Response	±0.4dB (22Hz to 20kHz @ Fs = 48kHz)
Signal to Noise Ratio	-103dB
THD	>93dB
Amplitude Linearity	<0.3dB @ -100dBFS
Crosstalk	-106dB (20Hz to 20kHz)

Max Power Consumption	
Audio Breakout Module	45W 3.75A 12V

Having a problem? Call our free, 24-hour technical support hotline to speak with a live product specialist located right here in our facility.

Tel: (+1) 613 • 652 • 4886
 Email: techsupport@rossvideo.com