

## Sony MVS-8000G Switcher

### Cable Connections

In an OverDrive system, a Sony MVS-8000G switcher connects to the OverDrive Server through a DeviceMaster and a Caprica Server.

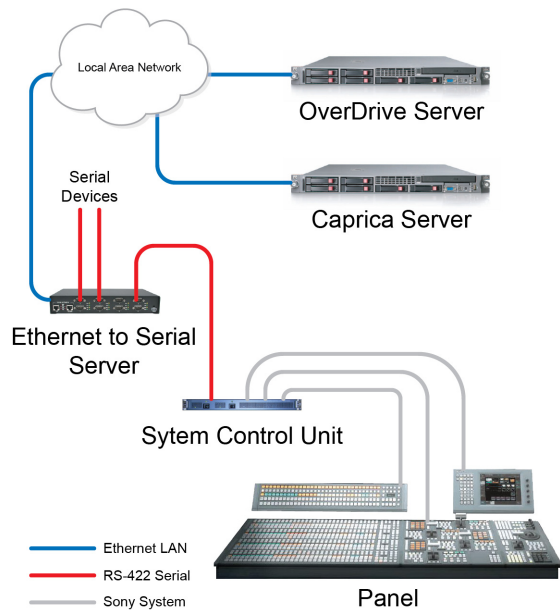

*Sony MVS-8000G Switcher Cable Connections*

### Switcher Device Port Configuration Settings

Use the following procedure to configure a switcher device for your Sony MVS-8000G switcher on the Caprica Server:

1. Use the current version of **DashBoard** software to connect to your **Caprica Server**.
2. In the **DashBoard Tree View**, double-click the **Port Configuration** node of your Caprica Server.
3. In the **Port Configuration Summary** table, double-click **SWITCHER1** in the **Port** column.
4. In the **Configure SWITCHER1** panel, click **Switcher**.
5. Click **Sony**.
6. Click **Network Settings**.

7. Use the following settings to configure the **Network Settings** for your switcher device:

- **Ethernet Role** — Client
- **Remote IP Address** — IP address of the Device Master or SeaLINK Ethernet to serial server that connects the Sony frame to your OverDrive system
- **Remote Port** — port number on the Ethernet to serial server.
  - › **DeviceMaster** — enter or select the port number on the DeviceMaster to which you connected your Sony frame.
  - › **SeaLINK** — enter or select the remote port number associated with the SeaLINK serial port number to which you connected your Sony XVS-8000 switcher. The SeaLINK serial port to remote port number associations are as follows:

SeaLINK Port	Remote Port
1	4680
2	4681
3	4682
4	4683

- **Local IP Address** — 0.0.0.0
- **Local Port** — 0
- **Protocol** — TCP

8. Click **Device Settings**.
9. Click the **Video Format** button to select the format of the video output from the Sony MVS-8000G switcher.
10. Click the **M/E** button to select the number of MEs on your Sony MVS-8000G switcher.
11. Use the **Half Rate** buttons to set how to handle timing for fields and frames. The available settings are as follows:
  - **ON** — click this button to handle 30 interlaced fields as 1 second.
  - **OFF** — click this button to handle interlaced fields as progressive frames: 30 interlaced fields equal 0.5 seconds, 60 progressive frames equal 1 second.
12. Use the **TransTimeout** box to enter or select the number of fields to wait for a transition completed message from the Sony MVS-8000G switcher.

13. Use the **TransMacroPosition** box to enter or select the starting position of the block of macros on the Sony MVS-8000G switcher used to support KeyAutoTrans and ME Cut functionality in OverDrive.
14. Use the **MemRecallTime** box to enter or select the delay in fields that the Sony MVS-8000G switcher requires to recall a memory, and completely report the new ME state.
15. Use the **ReportTransEndDelay** box to enter or select the delay in fields before the Sony MVS-8000G switcher reports the end of a PP transition.
16. Use the **MEState1Field** buttons to set how to handle how to send requests. The available settings are as follows:
  - **ON** — click this button to send multiple requests in a single field. Caprica will receive multiple responses and match the responses with the originating request.
  - **OFF** — click this button to send a single request in a field and wait for a response before sending another request.
17. Use the **FrameConvert** buttons to include or exclude Frame Converters as sources. The available settings are as follows:
  - **Not Include** — click this button to exclude Frame Converters from the Input list.
  - **Include** — click this button to include Frame Converters in the Input list.
18. Use the **Trans Mode** buttons to enable or disable polling of the Sony Trans Mode. The available settings are as follows:
  - **Enabled** — click this button to enable changing the keys in a transition through Sony Emems or macros.
  - **Disabled** — disable polling of the Sony Trans Mode.
19. Click the **Model** button and select **MVS8000**.
20. For the **Protocol** setting, click the **Serial** button.
21. Click **Apply Changes** to save the switcher settings.
22. Click **Done** to close the Configure SWITCHER1 panel.

**For More Information on...**

- configuring a Sony MVS-8000G Switcher for OverDrive, refer to the *Caprica User Guide*.

## Compatibility

Switcher	Version
Sony MVS-8000G	Latest

Automation	Version
OverDrive	15.1
Caprica Server	1.1a

Port Expanders	Support
Control DeviceMaster	Yes
Sealevel SeaLINK	Yes

## Contacting Technical Support

Technical Support is staffed by a team of experienced specialists ready to assist you with any question or technical issue.

Ross Video has technical support specialists strategically located around the globe to ensure a prompt response to technical inquiries. Our primary technical support center is located in Ottawa, Ontario, Canada. In addition, we have offices in The United Kingdom (London), Australia (Sydney), and Singapore with satellite locations in New York City, The Netherlands, and China. As we expand our presence globally, we are constantly evaluating other key locations to have a local technical support specialist in order to better service our customers.

### North America

Our North America center located in Ottawa, Ontario, Canada and is open Monday to Friday 8:30 a.m. to 6:00 p.m. EST, with 24/7/365 on-call service after hours.

Our telephone number is: +1-613-686-1557

Toll free within North America: +1 833-859-0499

### EMEA

Our EMEA center is open Monday to Friday 8:30 a.m. to 5:00 p.m. GMT. After hours support is provided by our North America location.

Our telephone number is: +44 (0)1189502446

International toll free: +800 3540 3545

If the local support specialist is not available, your call will be transferred automatically to our North America center.

## Australia

Our Sydney, Australia office is located in Alexandria, NSW.

Our local support telephone number is: 1300 007 677

If the local support specialist is not available, your call will be transferred automatically to our North America center.

## Online

E-mail: [techsupport@rossvideo.com](mailto:techsupport@rossvideo.com)

Website: open a support request using the link <https://support.rossvideo.com/> to open a support request.

## Copyright

© 2014 - 2024 Ross Video Limited. Ross®, MLE®, OverDrive®, GlobalView®, RundownControl™, DirectControl™, DirectAudio™, DirectAUXaudio™, DirectCamera™, DirectServer™, QuickTurn™, RapidRestore™, SideShot™, SideSlide™, SideStick™, OverDrive Gateway™, LiveLink™, and any related marks are trademarks or registered trademarks of Ross Video Limited. All other trademarks are the property of their respective companies. PATENTS ISSUED and PENDING. All rights reserved. No part of this publication may be reproduced, stored in a retrieval system, or transmitted in any form or by any means, mechanical, photocopying, recording or otherwise, without the prior written permission of Ross Video. While every precaution has been taken in the preparation of this document, Ross Video assumes no responsibility for errors or omissions. Neither is any liability assumed for damages resulting from the use of the information contained herein.