

## Ross Video Ultrix Carbonite Switcher

### Cable Connections

In an OverDrive system, an Ultrix Carbonite switcher connects to the OverDrive Server through a Caprica Server.

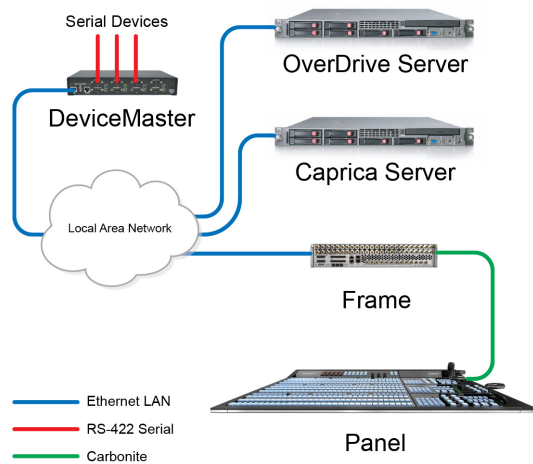

*Ultrix Carbonite Switcher Cable Connections*

### Switcher Device Port Configuration Settings

Use the following procedure to configure a switcher device for your Ultrix Carbonite switcher on the Caprica Server:

1. Use the current version of **DashBoard** software to connect to your **Caprica Server**.
2. In the **DashBoard Tree View**, double-click the **Port Configuration** node of your Caprica Server.
3. In the **Port Configuration Summary** table, double-click **SWITCHER1** in the **Port** column.
4. In the **Configure SWITCHER1** panel, click **Switcher**.
5. Click **CarboniteUltra**.
6. Click **Network Settings**.
7. Use the following settings to configure the **Network Settings** for your switcher device:
  - **Ethernet Role** — Client
  - **Remote IP Address** — IP address of your Ultrix Carbonite frame
  - **Remote Port** — 5253
  - **Local IP Address** — 0.0.0.0
  - **Local Port** — 0
  - **Protocol** — TCP
8. Click **Device Settings**.
9. Use the **MemRecallDelay** box to enter or select the number of fields to wait for memory recalls to complete.
10. Use the **CutTimeout** box to enter or select the number of fields to wait for Cut transitions to complete.
11. Use the **AutoTransDelay** box to enter or select the number of fields to wait for AutoTrans transitions to complete.
12. Click **PP Mapto** to select the ME, Canvas, or Scene on your Ultrix Carbonite switcher to map to the Program bus in Caprica. The ME mode set on the switcher limits the available options as follows:
  - **HD 2 ME 4 MM** — ME2 is not available in this mode.
  - **HD 3 ME** — mini MEs are not available in this mode.
13. Click **ME1 Mapto** to select the ME, Canvas, or Scene on your Ultrix Carbonite switcher to map to ME1 in Caprica. The ME mode set on the switcher limits the available options as follows:
  - **HD 2 ME 4 MM** — ME2 is not available in this mode.
  - **HD 3 ME** — mini MEs are not available in this mode.
14. Click **ME2 Mapto** to select the ME, Canvas, or Scene on your Ultrix Carbonite switcher to map to ME2 in Caprica. The ME mode set on the switcher limits the available options as follows:
  - **HD 2 ME 4 MM** — ME2 is not available in this mode.
  - **HD 3 ME** — mini MEs are not available in this mode.
15. Click **ME3 Mapto** to select the ME, Canvas, or Scene on your Ultrix Carbonite switcher to map to ME3 in Caprica. The ME mode set on the switcher limits the available options as follows:
  - **HD 2 ME 4 MM** — ME2 is not available in this mode.
  - **HD 3 ME** — mini MEs are not available in this mode.
16. Click **ME4 Mapto** to select the ME, Canvas, or Scene on your Ultrix Carbonite switcher to map to ME4 in Caprica. The ME mode set on the switcher limits the available options as follows:
  - **HD 2 ME 4 MM** — ME2 is not available in this mode.
  - **HD 3 ME** — mini MEs are not available in this mode.
17. Click **ME5 Mapto** to select the ME, Canvas, or Scene on your Ultrix Carbonite switcher to map to ME5 in Caprica. The ME mode set on the switcher limits the available options as follows:
  - **HD 2 ME 4 MM** — ME2 is not available in this mode.
  - **HD 3 ME** — mini MEs are not available in this mode.

18. Click **ME6 Mapto** to select the ME, Canvas, or Scene on your Ultrix Carbonite switcher to map to ME6 in Caprica. The ME mode set on the switcher limits the available options as follows:
  - **HD 2 ME 4 MM** — ME2 is not available in this mode.
  - **HD 3 ME** — mini MEs are not available in this mode.
19. Click **ME7 Mapto** to select the ME, Canvas, or Scene on your Ultrix Carbonite switcher to map to ME7 in Caprica. The ME mode set on the switcher limits the available options as follows:
  - **HD 2 ME 4 MM** — ME2 is not available in this mode.
  - **HD 3 ME** — mini MEs are not available in this mode.
20. Click **ME8 Mapto** to select the ME, Canvas, or Scene on your Ultrix Carbonite switcher to map to ME8 in Caprica. The ME mode set on the switcher limits the available options as follows:
  - **HD 2 ME 4 MM** — ME2 is not available in this mode.
  - **HD 3 ME** — mini MEs are not available in this mode.
21. Click **ME9 Mapto** to select the ME, Canvas, or Scene on your Ultrix Carbonite switcher to map to ME9 in Caprica. The ME mode set on the switcher limits the available options as follows:
  - **HD 2 ME 4 MM** — ME2 is not available in this mode.
  - **HD 3 ME** — mini MEs are not available in this mode.
22. Click **ME10 Mapto** to select the ME, Canvas, or Scene on your Ultrix Carbonite switcher to map to ME10 in Caprica. The ME mode set on the switcher limits the available options as follows:
  - **HD 2 ME 4 MM** — ME2 is not available in this mode.
  - **HD 3 ME** — mini MEs are not available in this mode.
23. Click **ME11 Mapto** to select the ME, Canvas, or Scene on your Ultrix Carbonite switcher to map to ME11 in Caprica. The ME mode set on the switcher limits the available options as follows:
  - **HD 2 ME 4 MM** — ME2 is not available in this mode.
  - **HD 3 ME** — mini MEs are not available in this mode.
24. Click **ME12 Mapto** to select the ME, Canvas, or Scene on your Ultrix Carbonite switcher to map to ME12 in Caprica. The ME mode set on the switcher limits the available options as follows:
  - **HD 2 ME 4 MM** — ME2 is not available in this mode.
  - **HD 3 ME** — mini MEs are not available in this mode.
25. Click **ME13 Mapto** to select the ME, Canvas, or Scene on your Ultrix Carbonite switcher to map to ME13 in Caprica. The ME mode set on the switcher limits the available options as follows:
  - **HD 2 ME 4 MM** — ME2 is not available in this mode.
  - **HD 3 ME** — mini MEs are not available in this mode.
26. Use the **MemRecallMode** buttons to set memory recall method to use. The available settings are as follows:
  - **UseSwMode** — use the memory recall mode set on the switcher to execute memory recalls.
  - **Program** — use the Program memory recall mode to execute memory recalls.
27. Use the **Use Accel** buttons to control the use of an experimental feature to improve communication performance between your Ultrix Carbonite switcher and Caprica Server. The available settings are as follows:
  - **Yes** — use this experiment feature.
  - **No** — do not use this experiment feature.
28. Use the **Keys 5-6 Xpts** buttons to prevent virtual inputs from shifting after updating an Ultrix Carbonite switcher to version 7.0 or greater. The available settings are as follows:
  - **Exclude** — use this setting to maintain virtual input positions after upgrading an Ultrix Carbonite switcher to version 7.0 or greater. Using this setting maintains virtual input positions for Custom Controls created for Ultrix Carbonite versions before version 7.0.
  - **Include** — use this setting to shift virtual inputs after updating an Ultrix Carbonite switcher to version 7.0 or greater. Custom Controls that use virtual inputs and were created for Ultrix Carbonite versions before version 7.0 may not work properly with this setting.
29. Use the **Scene Xpts** buttons to prevent virtual inputs from shifting after updating an Ultrix Carbonite switcher to version 7.0 or greater. The available settings are as follows:
  - **Exclude** — use this setting to maintain virtual input positions after upgrading an Ultrix Carbonite switcher to version 7.0 or greater. Using this setting maintains virtual input positions for Custom Controls created for Ultrix Carbonite versions before version 7.0.
  - **Include** — use this setting to shift virtual inputs after updating an Ultrix Carbonite switcher to version 7.0 or greater. Custom Controls that use virtual inputs and were created for Ultrix Carbonite versions before version 7.0 may not work properly with this setting.

30. Use the **ME 2 Xpts** buttons to prevent virtual inputs from shifting after switching an Ultrix Carbonite switcher to **HD 3 ME** mode on. The available settings are as follows:
  - **Exclude** — use this setting to maintain virtual input positions after switching to HD 3 ME mode. Using this setting maintains virtual input positions for Custom Controls created for your Ultrix Carbonite switcher when it was in HD 2 ME 4 MM mode.
  - **Include** — use this setting to shift virtual inputs after switching to HD 3 ME mode. Custom Controls that use virtual inputs and were created for your Ultrix Carbonite switcher when it was in HD 2 ME 4 MM mode may not work properly with this setting.
31. Use the **Trans Done** buttons to set the switcher response to transitions. The available settings are as follows:
  - **Disabled** — select this option when your switcher does not support this functionality.
  - **Enabled** — for switchers that support this functionality, select this option speed up the switcher response to transitions. This option makes OverDrive operation more reliable.
32. Use the **MemRecallDone** buttons to set the switcher response to memory recalls. The available settings are as follows:
  - **Disabled** — select this option when your switcher does not support this functionality.
  - **Enabled** — for switchers that support this functionality, select this option speed up the switcher response to memory recalls. This option makes OverDrive operation more reliable.
33. Click **Apply Changes** to save the switcher settings.
34. Click **Done** to close the Configure SWITCHER1 panel.

#### For More Information on...

- configuring an Ultrix Carbonite Switcher for OverDrive, refer to the *Caprica User Guide*.

#### Compatibility

Switcher	Version
Ross Video Ultrix Carbonite	11.0.0.X

Automation	Version
OverDrive	18.1
Caprica Server	4.4

#### Limitations

The following limitations apply to an OverDrive system configured with an Ultrix Carbonite switcher connected to the OverDrive system through a Caprica Server:

- The Fade To Black transition in Overdrive does not function. You can use the RossTalk FTB command or a GPI to make an Ultrix Carbonite switcher fade to and from black.
- You can not fully control your production system through the Ultrix Carbonite panel or DashBoard UI.

#### Contacting Technical Support

Technical Support is staffed by a team of experienced specialists ready to assist you with any question or technical issue.

Ross Video has technical support specialists strategically located around the globe to ensure a prompt response to technical inquiries. Our primary technical support center is located in Ottawa, Ontario, Canada. In addition, we have offices in The United Kingdom (London), Australia (Sydney), and Singapore with satellite locations in New York City, The Netherlands, and China. As we expand our presence globally, we are constantly evaluating other key locations to have a local technical support specialist in order to better service our customers.

#### North America

Our North America center located in Ottawa, Ontario, Canada and is open Monday to Friday 8:30 a.m. to 6:00 p.m. EST, with 24/7/365 on-call service after hours.

Our telephone number is: +1-613-686-1557

Toll free within North America: +1 833-859-0499

#### EMEA

Our EMEA center is open Monday to Friday 8:30 a.m. to 5:00 p.m. GMT. After hours support is provided by our North America location.

Our telephone number is: +44 (0)1189502446

International toll free: +800 3540 3545

If the local support specialist is not available, your call will be transferred automatically to our North America center.

#### Australia

Our Sydney, Australia office is located in Alexandria, NSW.

Our local support telephone number is: 1300 007 677

If the local support specialist is not available, your call will be transferred automatically to our North America center.

## Online

E-mail: [techsupport@rossvideo.com](mailto:techsupport@rossvideo.com)

Website: open a support request using the link  
<https://support.rossvideo.com/> to open a support request.

## Copyright

© 2014 - 2025 Ross Video Limited. Ross®, MLE®, OverDrive®, GlobalView®, RundownControl™, DirectControl™, DirectAudio™, DirectAUXaudio™, DirectCamera™, DirectServer™, QuickTurn™, RapidRestore™, SideShot™, SideSlide™, SideStick™, OverDrive Gateway™, LiveLink™, and any related marks are trademarks or registered trademarks of Ross Video Limited. All other trademarks are the property of their respective companies. PATENTS ISSUED and PENDING. All rights reserved. No part of this publication may be reproduced, stored in a retrieval system, or transmitted in any form or by any means, mechanical, photocopying, recording or otherwise, without the prior written permission of Ross Video. While every precaution has been taken in the preparation of this document, Ross Video assumes no responsibility for errors or omissions. Neither is any liability assumed for damages resulting from the use of the information contained herein.