

Ross Video Carbonite Black Switcher

Cable Connections

In an OverDrive system, a Carbonite Black switcher connects to the OverDrive Server through a Caprica Server.

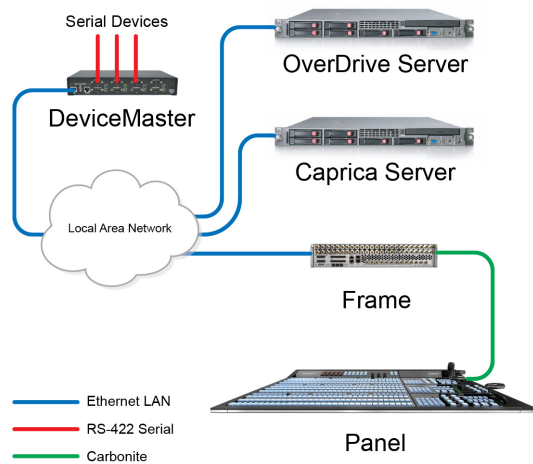

Carbonite Black Switcher Cable Connections

Switcher Device Port Configuration Settings

Use the following procedure to configure a switcher device for your Carbonite Black switcher on the Caprica Server:

1. Use the current version of **DashBoard** software to connect to your **Caprica Server**.
2. In the **DashBoard Tree View**, double-click the **Port Configuration** node of your Caprica Server.
3. In the **Port Configuration Summary** table, double-click **SWITCHER1** in the **Port** column.
4. In the **Configure SWITCHER1** panel, click **Switcher**.
5. Click **CarboniteBlack**.
6. Click **Network Settings**.
7. Use the following settings to configure the **Network Settings** for your switcher device:
 - **Ethernet Role** — Client
 - **Remote IP Address** — IP address of your Carbonite Black frame
 - **Remote Port** — 5253
 - **Local IP Address** — 0.0.0.0
 - **Local Port** — 0
 - **Protocol** — TCP

8. Click **Device Settings**.
9. Click **Inputs** to set the number of inputs on your Carbonite Black frame.
10. Use the **MemRecallDelay** setting to enter or select the number of fields to wait for memory recalls to complete.
11. Use the **CutTimeout** box to enter or select the number of frames to wait after a Cut transition until everything is “settled”, the transition is officially over, and Overdrive can continue.
12. Use the **AutoTimeout** box to enter or select the number of frames to wait after an AutoTrans transition until everything is “settled”, the transition is officially over, and Overdrive can continue.
13. Use the **AfterTrans** box to enter or select the number of frames to wait after Caprica confirms that a transition is complete.
14. Use the **Use Accel** buttons to control the use of an experimental feature to improve communication performance between your Carbonite Black switcher and Caprica Server. The available settings are as follows:
 - **Yes** — use this experiment feature.
 - **No** — do not use this experiment feature.
15. Click **Apply Changes** to save the switcher settings.
16. Click **Done** to close the Configure SWITCHER1 panel.

For More Information on...

- configuring a Carbonite Black Switcher for OverDrive, refer to the *Caprica User Guide*.

Compatibility

Switcher	Version
Ross Video Carbonite Black	11.0.0.X

Automation	Version
OverDrive	16.1
Caprica Server	4.0

Limitations

The following limitations apply to an OverDrive system configured with a Carbonite Black switcher connected to the OverDrive system through a Caprica Server:

- The Fade To Black transition in Overdrive does not function. You can use the RossTalk FTB command or a GPI to make a Carbonite Black switcher fade to and from black.
- You can not fully control your production system through the Carbonite Black panel or DashBoard UI.

Contacting Technical Support

Technical Support is staffed by a team of experienced specialists ready to assist you with any question or technical issue.

Ross Video has technical support specialists strategically located around the globe to ensure a prompt response to technical inquiries. Our primary technical support center is located in Ottawa, Ontario, Canada. In addition, we have offices in The United Kingdom (London), Australia (Sydney), and Singapore with satellite locations in New York City, The Netherlands, and China. As we expand our presence globally, we are constantly evaluating other key locations to have a local technical support specialist in order to better service our customers.

North America

Our North America center located in Ottawa, Ontario, Canada and is open Monday to Friday 8:30 a.m. to 6:00 p.m. EST, with 24/7/365 on-call service after hours.

Our telephone number is: +1-613-686-1557

Toll free within North America: +1 833-859-0499

EMEA

Our EMEA center is open Monday to Friday 8:30 a.m. to 5:00 p.m. GMT. After hours support is provided by our North America location.

Our telephone number is: +44 (0)1189502446

International toll free: +800 3540 3545

If the local support specialist is not available, your call will be transferred automatically to our North America center.

Australia

Our Sydney, Australia office is located in Alexandria, NSW.

Our local support telephone number is: 1300 007 677

If the local support specialist is not available, your call will be transferred automatically to our North America center.

Online

E-mail: techsupport@rossvideo.com

Website: open a support request using the link <https://support.rossvideo.com/> to open a support request.

Copyright

© 2014 - 2024 Ross Video Limited. Ross®, MLE®, OverDrive®, GlobalView®, RundownControl™, DirectControl™, DirectAudio™, DirectAUXaudio™, DirectCamera™, DirectServer™, QuickTurn™, RapidRestore™, SideShot™, SideSlide™, SideStick™, OverDrive Gateway™, LiveLink™, and any related marks are trademarks or registered trademarks of Ross Video Limited. All other trademarks are the property of their respective companies. PATENTS ISSUED and PENDING. All rights reserved. No part of this publication may be reproduced, stored in a retrieval system, or transmitted in any form or by any means, mechanical, photocopying, recording or otherwise, without the prior written permission of Ross Video. While every precaution has been taken in the preparation of this document, Ross Video assumes no responsibility for errors or omissions. Neither is any liability assumed for damages resulting from the use of the information contained herein.