

## Calrec Zeta Digital Audio Mixing System

Caprica can support up to 240 audio mixer faders. Source mapping is not available for audio mixers.

### Requirements

- Large Audio Mixer Interface Software Option
- Serial Interface Cable (DB9 to DB9)
- If the cable connection between the Ethernet to serial server and the Calrec Zeta Digital Audio Mixing System is longer than 50 feet, an RS-232 to RS-422 converter is required at the Calrec Zeta Digital Audio Mixing System.
- Control DeviceMaster or Sealevel SeaLINK
- Ethernet Cable

### Port Connections

Communications			
Audio Mixer RS-232	>	DeviceMaster or SeaLINK RS-232	
DeviceMaster or SeaLINK Ethernet	>	Local Area Network Ethernet	

### Serial Interface Cable Pinouts

The DeviceMaster and the SeaLINK Ethernet to serial servers both use the following serial interface cable pinouts:

Ethernet to Serial Server		Calrec Zeta Digital Audio Mixing System	
Pin	Signal	Pin	Signal
2	Rx	2	Tx
3	Tx	3	Rx
5	Ground	5	Ground

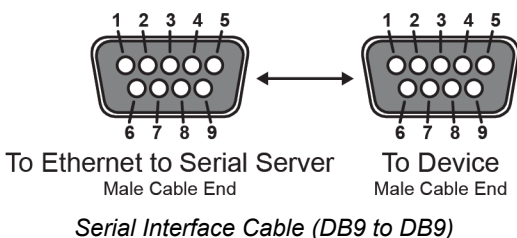

- ★ When using a SeaLINK Ethernet to serial server in your OverDrive system, terminate any control signals that are not going to be used. The most common way to do this is connect RTS to CTS and RI. Also, connect DCD to DTR and DSR.

### Configuring the Ethernet to Serial Server

The Ethernet to serial server in an OverDrive system handles the communication between your Calrec Zeta Digital Audio Mixing System and Caprica Server. OverDrive systems can contain a DeviceMaster or SeaLINK Ethernet to serial server. Use one of the following sections to configure the Ethernet to serial server in your OverDrive System:

- “DeviceMaster” on page 4–1
- “SeaLINK” on page 4–2

### DeviceMaster

Calrec Zeta Digital Audio Mixing System. Use the following procedure to configure the DeviceMaster for your Calrec Zeta Digital Audio Mixing System:

1. Use a web browser to open the **Server Status** web page for your DeviceMaster. The default IP address for a DeviceMaster is 192.168.250.250.  
The **Server Status** web page opens in the web browser.
2. Click **Port #** link, where # is the port number on the DeviceMaster to which you connect your Calrec Zeta Digital Audio Mixing System.  
The **Edit Port # Configuration** web page opens for the selected port.
3. In the **Port Name** box, enter `Calrec Zeta`.
4. In the **Serial Configuration** section, use the **Mode** list to select **RS-232**.
5. Use the **Baud** list to select **115200**.
6. Use the **Parity** list to select **odd**.
7. Use the **Data Bits** list to select **8**.
8. Use the **Stop Bits** list to select **1**.
9. Use the **DTR** list to select **off**.
10. Use the **EOL** list to select **disabled**.
11. In the **TCP Connection Configuration** section, select the **Enable** check box.

12. Select the **Listen** check box.
13. In the **Port** box, enter the port number that the DeviceMaster uses to listen for communication from the Calrec Zeta Digital Audio Mixing System.
14. Click **Save**.  
The **Port Configuration Updated** web page opens.
15. Click **OK**.  
The **Server Status** web page opens.
16. Click **Reboot**.  
The DeviceMaster reboots with the new configuration.

## SeaLINK

The Calrec Zeta Digital Audio Mixing System connects to a serial port on the SeaLINK. You must configure the connected SeaLINK serial port to communicate with the Calrec Zeta Digital Audio Mixing System.

### Hardware Configuration

The SeaLINK Ethernet to serial server is primarily configured using the web interface. Before using the web interface, the SeaLINK DB9 port that connects the Calrec Zeta Digital Audio Mixing System to your OverDrive system requires DIP Switch configuration.

Inside the SeaLINK each DB9 serial port has a set of eight DIP Switches. To communicate with the Calrec Zeta Digital Audio Mixing System the RS Mode of the DB 9 serial port that connects the must be set to RS-232. For your model of SeaLINK, set the DIP Switches associated with the connected port as follows:

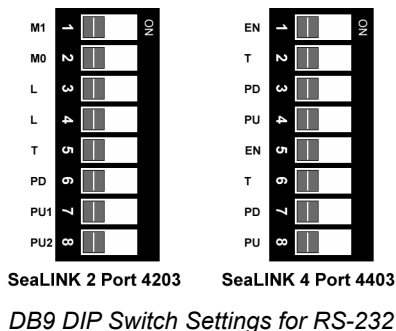

### For More Information on...

- configuring the DIP Switches for SeaLINK DB9 ports, refer to the **Hardware Configuration** section in the *SeaLINK User Manual | Ethernet Serial Server Family*.

### Web Interface Configuration

After setting the DIP Switches associated with the DB9 port on the SeaLINK used to connect the Calrec Zeta Digital Audio Mixing System, you can use the SeaLINK web interface to complete the SeaLINK configuration.

Use the following procedure to configure the SeaLINK for your Calrec Zeta Digital Audio Mixing System:

1. Use a web browser to open the **Summary** web page for your SeaLINK. The URL of the Summary web page is the IP address of the SeaLINK.  
The **Summary** web page opens in the web browser.
  2. Click the **Port Settings** tab.  
The **Port Settings** web page opens.
  3. In the **Port # Defaults Section** section, where # is the port number on the SeaLINK to which you connect your Calrec Zeta Digital Audio Mixing System, enter 115200 in the **Baud Rate** box.
  4. Use the **Data Bits** list to select **8**.
  5. Use the **Stop Bits** list to select **1**.
  6. Use the **Parity** list to select **Odd**.
  7. Use the **Flow Control** list to select **None**.
  8. Use the **RS Mode** list to select **RS 232**.
  9. Use the **Protocol** list to select **Ignored**.
  10. Click **Submit**.
  11. Click the **Administration** tab.  
The **Administration** web page opens.
- ★ Values set for settings on the **Administration** web page are set for all SeaLINK serial ports.
12. In the **General Settings** section, enter a name to identify the SeaLINK in the **Name** box.
  13. Use the **Connection Protocol** list to select **Raw Data**.
  14. At the bottom of the **Administration** web page, select the **Reboot** check box.
  15. Click **Submit**.  
The SeaLINK reboots with the new configuration.

## Remote Device Port Configuration Settings

Use the following procedure to configure a remote device for your Calrec Zeta Digital Audio Mixing System on the Caprica Server:

1. Use the current version of **DashBoard** software to connect to your **Caprica Server**.
2. In the **DashBoard Tree View**, double-click the **Port Configuration** node of your Caprica Server.
3. In the **Port Configuration Summary** table, double-click a **REMOTE#** port in the **Port** column.
4. In the **Configure REMOTE#** panel, click **Audio Mixer**.
5. Click **RAP**.
6. Click **Network Settings**.
7. Use the following settings to configure the **Network Settings** for your Calrec Zeta Digital Audio Mixing System:

- **Ethernet Role** — Client
- **Remote IP Address** — IP address of the Ethernet to serial server in your OverDrive system
- **Remote Port** — Port number on the Ethernet to serial server to which you connect your Calrec Zeta Digital Audio Mixing System.

When using a SeaLINK Ethernet to serial server in your OverDrive system the Remote Port number is associated with the SeaLINK serial port number to which you connected your Calrec Zeta Digital Audio Mixing System. The SeaLINK serial port to Remote Port associations are as follows:

SeaLINK Serial Port	Remote Port
1	4680
2	4681
3	4682
4	4683

- **Local IP Address** — 0.0.0.0
  - **Local Port** — 0
  - **Protocol** — TCP
8. Click **Device Settings**.
  9. Use the following settings to configure the **Device Settings** for your Calrec Zeta Digital Audio Mixing System:
    - **TargetMachine** — Calrec
    - **Ctrl Master** — M1
    - **Multiplier** — 2

10. Click **Apply Changes** to save the device settings.
11. Click **Done** to close the Configure REMOTE# panel.

### For More Information on...

- configuring remote devices for OverDrive systems that contain a Caprica Server, refer to the *Caprica User Guide*.

## Device Setup

Ensure the port on the Calrec Zeta Digital Audio Mixing System that is connected to the Ethernet to serial server is configured for RS-232.

## Compatibility

Audio Mixer	Version
Calrec Zeta Digital Audio Mixing System	-

Automation	Version
OverDrive	15.0 or higher
Caprica Server	1.0a or higher

Port Expanders	Support
Control DeviceMaster	Yes
Sealevel SeaLINK	Yes

## Contacting Technical Support

Technical Support is staffed by a team of experienced specialists ready to assist you with any question or technical issue.

Ross Video has technical support specialists strategically located around the globe to ensure a prompt response to technical inquiries. Our primary technical support center is located in Ottawa, Ontario, Canada. In addition, we have offices in The United Kingdom (London), Australia (Sydney), and Singapore with satellite locations in New York City, The Netherlands, and China. As we expand our presence globally, we are constantly evaluating other key locations to have a local technical support specialist in order to better service our customers.

### North America

Our North America center located in Ottawa, Ontario, Canada and is open Monday to Friday 8:30 a.m. to 6:00 p.m. EST, with 24/7/365 on-call service after hours.

Our telephone number is: +1-613-686-1557

Toll free within North America: +1 833-859-0499

## EMEA

Our EMEA center is open Monday to Friday 8:30 a.m. to 5:00 p.m. GMT. After hours support is provided by our North America location.

Our telephone number is: +44 (0)1189502446

International toll free: +800 3540 3545

If the local support specialist is not available, your call will be transferred automatically to our North America center.

## Australia

Our Sydney, Australia office is located in Alexandria, NSW.

Our local support telephone number is: 1300 007 677

If the local support specialist is not available, your call will be transferred automatically to our North America center.

## Online

E-mail: [techsupport@rossvideo.com](mailto:techsupport@rossvideo.com)

Website: open a support request using the link <https://support.rossvideo.com/> to open a support request.

## Copyright

© 2014 - 2024 Ross Video Limited. Ross®, MLE®, OverDrive®, GlobalView®, RundownControl™, DirectControl™, DirectAudio™, DirectAUXaudio™, DirectCamera™, DirectServer™, QuickTurn™, RapidRestore™, SideShot™, SideSlide™, SideStick™, OverDrive Gateway™, LiveLink™, and any related marks are trademarks or registered trademarks of Ross Video Limited. All other trademarks are the property of their respective companies. PATENTS ISSUED and PENDING. All rights reserved. No part of this publication may be reproduced, stored in a retrieval system, or transmitted in any form or by any means, mechanical, photocopying, recording or otherwise, without the prior written permission of Ross Video. While every precaution has been taken in the preparation of this document, Ross Video assumes no responsibility for errors or omissions. Neither is any liability assumed for damages resulting from the use of the information contained herein.