

VOYAGER

# Maintenance Guide

VERSION 02

**ROSS**

# Thank You for Choosing Ross

You've made a great choice. We expect you will be very happy with your purchase of Ross Technology.

Our mission is to:

1. Provide a Superior Customer Experience
  - offer the best product quality and support
2. Make Cool Practical Technology
  - develop great products that customers love

Ross has become well known for the Ross Video Code of Ethics. It guides our interactions and empowers our employees. I hope you enjoy reading it below.

If anything at all with your Ross experience does not live up to your expectations be sure to reach out to us at [solutions@rossvideo.com](mailto:solutions@rossvideo.com).



David Ross

CEO, Ross Video

[dross@rossvideo.com](mailto:dross@rossvideo.com)

## Ross Video Code of Ethics

Any company is the sum total of the people that make things happen. At Ross, our employees are a special group. Our employees truly care about doing a great job and delivering a high quality customer experience every day. This code of ethics hangs on the wall of all Ross Video locations to guide our behavior:

1. We will always act in our customers' best interest.
2. We will do our best to understand our customers' requirements.
3. We will not ship crap.
4. We will be great to work with.
5. We will do something extra for our customers, as an apology, when something big goes wrong and it's our fault.
6. We will keep our promises.
7. We will treat the competition with respect.
8. We will cooperate with and help other friendly companies.
9. We will go above and beyond in times of crisis. *If there's no one to authorize the required action in times of company or customer crisis - do what you know in your heart is right. (You may rent helicopters if necessary.)*

# Voyager Maintenance Guide

- Ross Part Number: 3808DR-040-02 Rev 2
- Version: 02

The information contained in this guide is subject to change without notice or obligation.

## Copyright

©2024 Ross Video Limited, Ross®, and any related marks are trademarks or registered trademarks of Ross Video Limited. All other trademarks are the property of their respective companies. PATENTS ISSUED and PENDING. All rights reserved. No part of this publication may be reproduced, stored in a retrieval system, or transmitted in any form or by any means, mechanical, photocopying, recording or otherwise, without the prior written permission of Ross Video. While every precaution has been taken in the preparation of this document, Ross Video assumes no responsibility for errors or omissions. Neither is any liability assumed for damages resulting from the use of the information contained herein.

## Patents

Patent numbers US 7,034,886; US 7,508,455; US 7,602,446; US 7,802,802 B2; US 7,834,886; US 7,914,332; US 8,307,284; US 8,407,374 B2; US 8,499,019 B2; US 8,519,949 B2; US 8,743,292 B2; GB 2,419,119 B; GB 2,447,380 B; and other patents pending.

## Notice

The material in this manual is furnished for informational use only. It is subject to change without notice and should not be construed as commitment by Ross Video Limited. Ross Video Limited assumes no responsibility or liability for errors or inaccuracies that may appear in this manual.

# Important Regulatory and Safety Notices to Service Personnel

Before using this product and any associated equipment, refer to the "Important Safety Instructions" listed below so as to avoid personal injury and to prevent product damage.

Products may require specific equipment, and /or installation procedures be carried out to satisfy certain regulatory compliance requirements. Notices have been included in this publication to call attention to these specific requirements.

## Symbol Meanings



**Protective Earth** — This symbol identifies a Protective Earth (PE) terminal, which is provided for connection of the supply system's protective earth (green or green/yellow) conductor.



The exclamation point within an equilateral triangle is intended to alert the user to the presence of important operating and maintenance (servicing) instructions in the literature accompanying the product. Failure to heed this information may present a risk of damage or injury to persons or equipment.



**Warning** — The symbol with the word "**Warning**" within the equipment manual indicates a potentially hazardous situation, which if not avoided, could result in death or serious injury



**Caution** — The symbol with the word "**Caution**" within the equipment manual indicates a potentially hazardous situation, which if not avoided, may result in minor or moderate injury. It may also be used to alert against unsafe practices.



**Notice** — The symbol with the word "**Notice**" within the equipment manual indicates a situation, which if not avoided, may result in major or minor equipment damage or a situation, which could place the equipment in a non-compliant operating state.



**Warning Hazardous Voltage** — The lightning flash with arrowhead symbol within an equilateral triangle is intended to alert the user to the presence of uninsulated "dangerous voltage" within the product's enclosure that may be of sufficient magnitude to constitute a risk of shock to persons



**ESD Susceptibility** — This symbol is used to alert the user that an electrical or electronic device or assembly is susceptible to damage from an ESD event.

## Important Safety Instructions

- 1) Read these instructions.
- 2) Follow all instructions and heed all warnings.
- 3) Refer all servicing to qualified service personnel.
- 4) The equipment's AC appliance inlets are the means to disconnect the product from the AC Mains and must remain readily operable for this purpose.
- 5) Parts of the equipment's power supplies can still present a safety hazard even when the product is in the "OFF" state. To avoid the risk of electrical shock and to completely disconnect the apparatus from the AC Mains, remove all power supply cords from the product's AC appliance inlets prior to servicing.
- 6) If the product nameplate indicates that the chassis is "Rack Mounted", it is to be rack mounted only. To ensure safe operation and maintain long-term system reliability, proper installation requires that the front and back area of the chassis remain clear of obstructions so as not to restrict airflow.
- 7) The Optical Disk Drive within this product is a "Laser - Class 1 product".



### **Warning**

8) No operator access to internal parts in this product. The power supply outputs are considered an Energy Hazard (>240VA). To avoid the risk of contact with the Energy Hazard and to completely de-energize the apparatus, remove all power supply cords from the product's AC appliance inlet(s) prior to servicing.



### **Warning**

9) Indoor Use: To reduce the risk of fire or electric shock, do not expose this apparatus to rain or moisture.



### **Warning**

10) This product includes an "Ethernet Port" which allows this product to be connected to a local area network (LAN). Only connect to networks that remain inside the building. Do not connect to networks that go outside the building.



### **Caution**

11) This apparatus contains a Lithium battery, which if replaced incorrectly, or with an incorrect type, may cause an explosion. Replace only with the same type recommended by the manufacturer. Dispose of used batteries according to the manufacturer's instruction by qualified service personnel.



### **Caution / Attention**

12) This unit may have more than one power supply cord. Disconnect all power supply cords before servicing to avoid electric shock / Cet appareil peut comporter plus d'un cordon d'alimentation. Afin de prévenir les chocs électriques, débrancher tous les cordons d'alimentation avant de faire le dépannage.

## Use of Hazardous Substances in Electrical and Electronic Products (China RoHS)

Ross Video Limited has reviewed all components and processes for compliance to:

“Management Methods for the Restriction of the Use of Hazardous Substances in Electrical and Electronic Products” also known as China RoHS.

The “Environmentally Friendly Use Period” (EFUP) and Hazardous Substance Tables have been established for all products.

The Hazardous substances tables are available on our website at:

<http://www.rossvideo.com/about-ross/company-profile/green-practices/china-rohs.html>

电器电子产品中有害物质的使用

Ross Video Limited 按照以下的标准对所有组件和流程进行了审查：

“电器电子产品有害物质限制使用管理办法”也被称为中国RoHS。

所有产品都具有“环保使用期限”(EFUP)和有害物质表。目前，我们正在更新我们所有的产品手册。

有害物质表在我们的网站：

<http://www.rossvideo.com/about-ross/company-profile/green-practices/china-rohs.html>

## EMC Notices

### US

#### FCC Part 15

This equipment has been tested and found to comply with the limits for a class A Digital device, pursuant to part 15 of the FCC Rules. These limits are designed to provide reasonable protection against harmful interference when the equipment is operated in a Commercial environment. This equipment generates, uses, and can radiate radio frequency energy and, if not installed and used in accordance with the instruction manual, may cause harmful interference to radio communications. Operation of this equipment in a residential area is likely to cause harmful interference in which case the user will be required to correct the interference at his own expense.

**Notice**

Changes or modifications to this equipment not expressly approved by Ross Video Ltd. could void the user's authority to operate this equipment.

### CANADA

This Class "A" digital apparatus complies with Canadian **ICES-003**.

Cet appareil numerique de la classe "A" est conforme a la norme **NMB-003** du Canada.

### EUROPE

This equipment is in compliance with the essential requirements and other relevant provisions of **CE Directive 93/68/EEC**.

### AUSTRALIA

This equipment has been tested to **AS/NZS CISPR32:2015 AMD1:2020** and found to comply with the limits for a Class A Digital device.

### INTERNATIONAL

This equipment has been tested to **CISPR 32:2015 AMD1:2019** and found to comply with the limits for a Class A Digital device.

**Notice**

This is a Class A product. In domestic environments, this product may cause radio interference, in which case the user may have to take adequate measures.

### KOREA

이 기기는 업무용(A급) 전자파적합기기로서 판매자 또는 사용자는 이 점을 주의하시기 바라며, 가정외의 지역에서 사용하는 것을 목적으로 합니다.

# Warranty and Repair Policy

Ross Video Limited (Ross) warrants its Voyager systems to be free from defects under normal use and service for the following time periods from the date of shipment:

- Voyager Server — 12 months
- Voyager Software Upgrades — 12 months free of charge
- System and Media hard drives — 12 months

If an item becomes defective within the warranty period Ross will repair or replace the defective item, as determined solely by Ross.

Warranty repairs will be conducted at Ross, with all shipping FOB Ross dock. If repairs are conducted at the customer site, reasonable out-of-pocket charges will apply. At the discretion of Ross, and on a temporary loan basis, plug in circuit boards or other replacement parts may be supplied free of charge while defective items undergo repair. Return packing, shipping, and special handling costs are the responsibility of the customer.

This warranty is void if products are subjected to misuse, neglect, accident, improper installation or application, or unauthorized modification.

In no event shall Ross Video Limited be liable for direct, indirect, special, incidental, or consequential damages (including loss of profit). Implied warranties, including that of merchantability and fitness for a particular purpose, are expressly limited to the duration of this warranty.

This warranty is TRANSFERABLE to subsequent owners, subject to Ross' notification of change of ownership.

## Extended Warranty

For customers that require a longer warranty period, Ross offers an extended warranty plan to extend the standard warranty period by one year increments. For more information about an extended warranty for your Voyager system, contact your regional sales manager.

# Environmental Information

The equipment that you purchased required the extraction and use of natural resources for its production. It may contain hazardous substances that could impact health and the environment.

To avoid the potential release of those substances into the environment and to diminish the need for the extraction of natural resources, Ross Video encourages you to use the appropriate take-back systems. These systems will reuse or recycle most of the materials from your end-of-life equipment in an environmentally friendly and health conscious manner.

The crossed-out wheeled bin symbol invites you to use these systems.



If you need more information on the collection, reuse, and recycling systems, please contact your local or regional waste administration.

You can also contact Ross Video for more information on the environmental performances of our products.

# Company Address

## **Ross Video Limited**

8 John Street  
Iroquois, Ontario  
Canada, K0E 1K0

## **Ross Video Incorporated**

P.O. Box 880  
Ogdensburg, New York  
USA 13669-0880

---

**General Business Office:** (+1) 613 · 652 · 4886

**Fax:** (+1) 613 · 652 · 4425

**Toll Free Technical Support:** 1-844-652-0645 (North America)

+800 1005 0100 (International)

**Alternately, you can contact:**

**Technical Support:** (+1) 613 · 652 · 4886

**After Hours Emergency:** (+1) 613 · 349 · 0006

**E-mail for Technical Support:** [techsupport@rossvideo.com](mailto:techsupport@rossvideo.com)

**E-mail for General Information:** [solutions@rossvideo.com](mailto:solutions@rossvideo.com)

**Website:** <http://www.rossvideo.com>

# Contents

<b>Introduction</b> .....	<b>1</b>
About This Guide .....	1
Getting Help .....	2
<b>Hardware Overview</b> .....	<b>3</b>
Front View of the System .....	4
Power LED Area .....	5
HDD Alarm LED Area .....	6
Voyager SDI Rear Input/Output Connections .....	7
Voyager IP Rear Input/Output Connections .....	8
Voyager 12G Rear Input/Output Connections .....	9
Rear Peripheral Connections .....	10
Power Supplies .....	11
<b>Hardware Installation</b> .....	<b>12</b>
Installation Requirements .....	13
Installing the System in an Equipment Rack .....	14
Attaching the Cables .....	15
Powering the System Up and Down .....	17
<b>Hard Drive Maintenance</b> .....	<b>18</b>
MegaRAID Storage Manager .....	19
RAID Array Consistency Check .....	21
RAID Array Drive Replacement .....	22
<b>Hardware Maintenance</b> .....	<b>26</b>
Replacing a System Drive .....	27
Removing and Reinstalling the Top Panel .....	32
Replacing Cooling Fans .....	36
Replacing the Front Chassis Fan .....	37
Replacing the Inside Chassis Fan .....	46
Replacing the Rear Chassis Fan .....	48
Replacing the System Drive Fan .....	50
Replacing Power Supplies .....	52
Accessing the USB Security Dongle .....	55

Appendix A: Matrox SDI I/O Cables .....	56
Appendix B: Matrox 12G I/O Cables .....	58
Appendix C: AJA Corvid 88 I/O Cables .....	59

# Introduction

Thank you for choosing a Ross Video Voyager system.

Ross Video designed Voyager with the needs of live production in mind. Voyager is an easy to use, yet powerful, 3D graphics and character generator. There are a range of Voyager systems tailored to suit a variety of needs.

We appreciate your business and sincerely hope that you have a great experience with your new Voyager system. As always, if there is anything we at Ross Video can do to assist you, please do not hesitate to contact us.

## About This Guide

This guide covers the installation and maintenance of the Voyager system. Refer to this guide and the accompanying *Quick Start Guide* when you first install or need to reconfigure your system.

If, at any time, you have questions pertaining to the operation of the Voyager system, please contact Ross Video at the numbers listed in the section [Getting Help](#)<sup>24</sup>. Our technical staff are always available for consultation, training, or service.

## Documentation Conventions

Special text formats are used in this guide to identify parts of the user interface, text that a user must enter, or a sequence of menus and sub-menus that must be followed to reach a particular command.

**Bold text** Bold text identifies a user interface element such as a dialog box, menu item, or button.

For example:

In the **Slug** column, type a slug name for the story.

*Italic text* Italic text is used to identify the titles of referenced guides, manuals, or documents.

For example:

For more information, refer to the *DashBoard User Guide*.

Courier text Courier text identifies text that a user must type.

For example:

In the **Username** box, type `postgres`.

[Hypertext](#) Identifies a hyperlink to a related topic.

## Getting Help

Voyager documentation is available online at [Product Documentation](#) and is also accessible on the product USB key and by clicking on the **Help** icon in the user interface.

## Contacting Technical Support

At Ross Video, we take pride in the quality of our products, but if problems occur, help is as close as the nearest telephone.

Our 24-hour Hot Line service ensures you have access to technical expertise around the clock. After-sales service and technical support is provided directly by Ross Video personnel. During business hours (Eastern Time), technical support personnel are available by telephone. After hours and on weekends, a direct emergency technical support phone line is available. If the technical support person who is on call does not answer this line immediately, a voice message can be left and the call will be returned shortly. This team of highly trained staff is available to react to any problem and to do whatever is necessary to ensure customer satisfaction.

### Technical Support:

- 1-844-652-0645 (North America)
- +800 1005 0100 (International)
- After Hours Emergency: (+1) 613-349-0006
- E-mail: [techsupport@rossvideo.com](mailto:techsupport@rossvideo.com)
- Website: <http://www.rossvideo.com>

# Hardware Overview

This section provides a brief overview of the Voyager system hardware.

The topics described in this chapter are:

[Front View of the System](#) 

[Power LED Area](#) 

[HDD Alarm LED Area](#) 

[Voyager SDI Rear Input/Output Connections](#) 

[Voyager IP Rear Input/Output Connections](#) 

[Voyager 12G Rear Input/Output Connections](#) 

[Rear Peripheral Connections](#) 

[Power Supplies](#) 

## Front View of the System

The following diagram displays the front of the Voyager system with the front door removed. Descriptions of individual components are contained in the legend below the diagram.

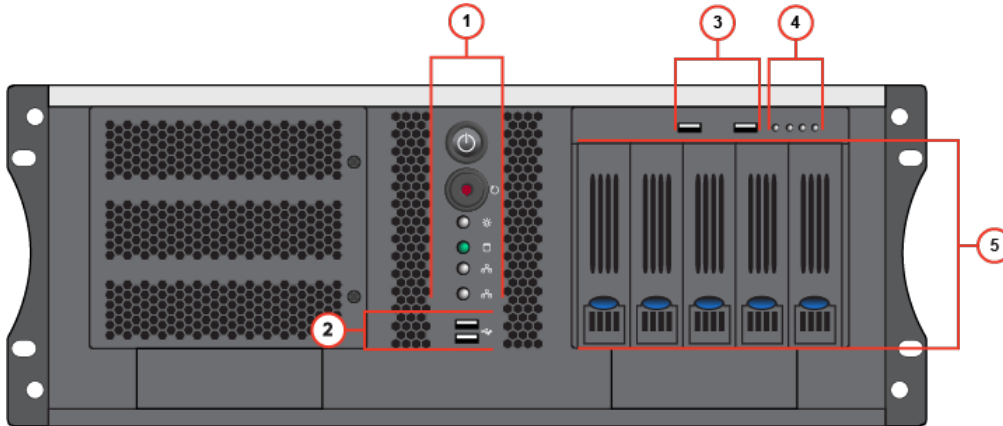

Front View of XPression 4RU System

- 1) **Power LED Area** — This area includes the Voyager system **Power** button and LEDs for system components.  
Refer to the section [Power LED Area](#) <sup>[5]</sup> for more information.
- 2) **USB Ports** — These ports can be used to transfer media to and from USB drives.
- 3) **HDD USB Ports** — These ports are inactive.

- 4) **HDD Alarm LED Area** — This area includes the alarm LEDs for the HDD hardware.  
Refer to the section [HDD Alarm LED Area](#) <sup>[6]</sup> for further information.
- 5) **System Drives** — Voyager 4RU systems are equipped with five drives in a RAID 1 (system drives) and RAID 5 (media drives) configuration to provide redundancy in case of a drive failure.  
This arrangement allows for a single drive failure without loss of data or performance.

## Power LED Area

The Power LED area is located on the front of the Voyager system, in the middle top of the chassis. This area contains the **Power** button for the Voyager system, as well as activity LEDs for system components. Refer to the section [Front View of the System](#) to locate the **Power LED Area** on the front of the Voyager system.

The following diagram displays the **Power LED** area of the Voyager system. Individual components are described in the legend below the diagram.

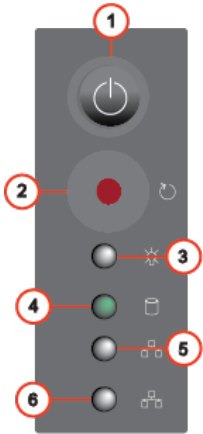

Power LED Area

- |   |  |
|---|--|
| <ol style="list-style-type: none"><li>1) <b>Power Button</b> — Press this button to begin the boot procedure. Press and hold the button for five seconds to power down the system after a hardware or software failure.</li><li>2) <b>Reset Button</b> — Press this button to reset the system after a hardware or software failure. Pressing this button also reboots the system.</li><li>3) <b>Power Active Indicator LED</b> — This LED is active when the system is powered on.</li></ol> | <ol style="list-style-type: none"><li>4) <b>Hard Disk Activity LED</b> — This LED activates when there is read/write activity on any system hard disk.</li><li>5) <b>Network 1 Activity LED</b> — This LED is not active.</li><li>6) <b>Network 2 Activity LED</b> — This LED is not active.</li></ol> |
|---|--|

## HDD Alarm LED Area

The HDD Alarm LED area is located on the front of the Voyager system, at the top-right of the chassis above the system drives. This area contains the alarm LEDs for the HDD hardware. Refer to the section [Front View of the System](#) to locate the HDD Alarm LED area on the front of the Voyager system.

The following diagram displays the HDD Alarm LED Area of the Voyager system. Individual components are described in the legend below the diagram.

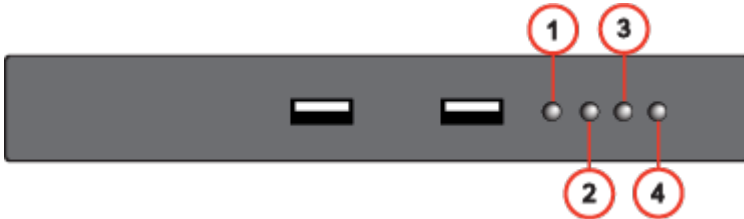

*HDD Power and Status LED Area*

- |   |   |
|---|---|
| 1) <b>Alarm Mute Button</b> — The alarm mute button is not active.  | 3) <b>Fan Failure Alarm LED</b> — This LED activates when a cooling fan in the HDD hardware has failed and requires replacing. This LED is accompanied by an audible alarm. |
| 2) <b>Temperature Alarm LED</b> — This LED activates when the temperature inside the HDD hardware rises above the recommended operating temperature. This LED is accompanied by an audible alarm. | 4) <b>HDD Failure Alarm LED</b> — This LED activates when one or more system drives in the HDD hardware has failed. This LED is accompanied by an audible alarm.            |

# Voyager SDI Rear Input/Output Connections

The following diagram displays the **Input/Output** portion of the Voyager system. Individual components are described in the legend below the diagram.

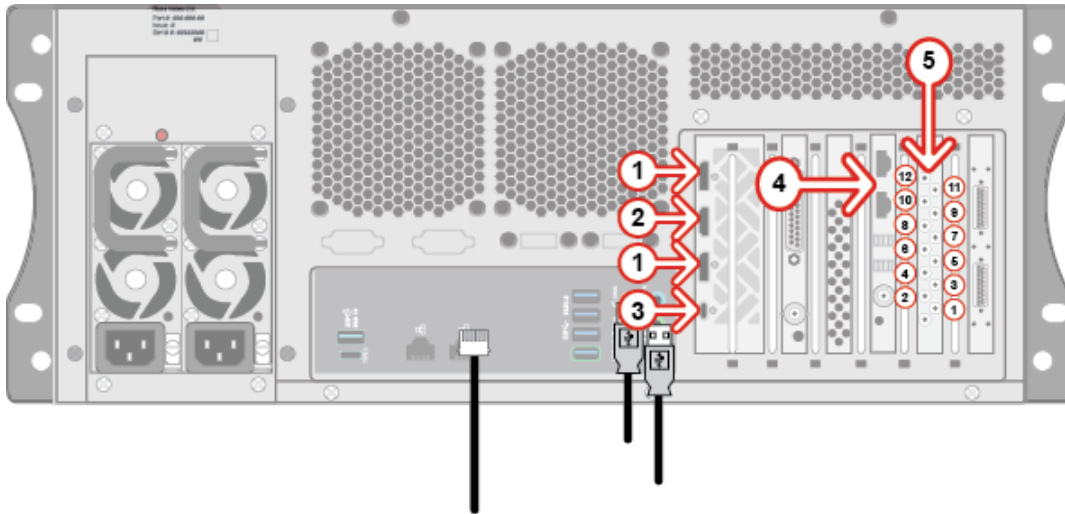

*Voyager SDI Rear Input/Output Connections*

- |  |   |
|--|---|
| <ol style="list-style-type: none"><li>1) <b>Display Ports</b> — Two Display Ports provide output for computer monitors. Ensure the correct display port to DVI adapters are used (DIV-D or DVI-I).</li><li>2) <b>HDMI Port</b> — One HDMI port (b) provides output for a computer monitor.</li><li>3) <b>USB-C Port</b> — One USB-C port (c) provides output for a computer monitor.</li><li>4) <b>nVidia Quadro Sync II</b> — Two Frame Lock connections for synchronizing multiple displays. Connect using <b>CAT-6 UTP Ethernet</b> cables.</li></ol> | <ol style="list-style-type: none"><li>5) <b>Matrox Video Input/Output Cables</b> — Provide SDI video input and output, as well as an analog reference point. Refer to <a href="#">Appendix A: Matrox SDI I/O Cables</a> for further information.</li></ol> <p><b>OR</b></p> <p><b>AJA Corvid 88 Video Input/Output Cables</b> — Provide SDI video input and output, as well as an analog reference point. Refer to <b>Appendix C: AJA Corvid 88 I/O Cables</b> for further information.</p> |
|--|---|

## Voyager IP Rear Input/Output Connections

The following diagram displays the **Input/Output** portion of the Voyager IP system. Individual components are described in the legend below the diagram.

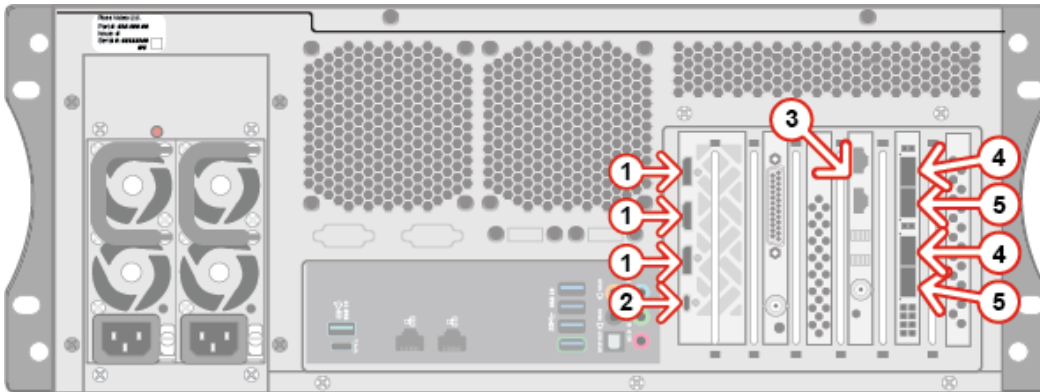

*Voyager IP Rear Input/Output Connections*

- |  |  |
|--|--|
| <ol style="list-style-type: none"><li>1) <b>Display Ports</b> — Three Display Ports provide output for computer monitors. Ensure the correct display port to DVI adapters are used (DVI-D or DVI-I).</li><li>2) <b>USB-C Port</b> — One USB-C port provides output for a computer monitor.</li><li>3) <b>nVidia Quadro Sync II</b> — Two Frame Lock connections for synchronizing multiple displays. Connect using <b>CAT-6 UTP Ethernet</b> cables.</li></ol> | <ol style="list-style-type: none"><li>4) <b>SFP Cage 1</b> — Two connections for a small form-factor pluggable SFP for attaching a networking cable.</li><li>5) <b>SFP Cage 2</b> — Two connections for a small form-factor pluggable SFP for attaching a networking cable, when using redundancy.</li></ol> |
|--|--|

# Voyager 12G Rear Input/Output Connections

The following diagram displays the **Input/Output** portion of the Voyager 12G system. Individual components are described in the legend below the diagram.

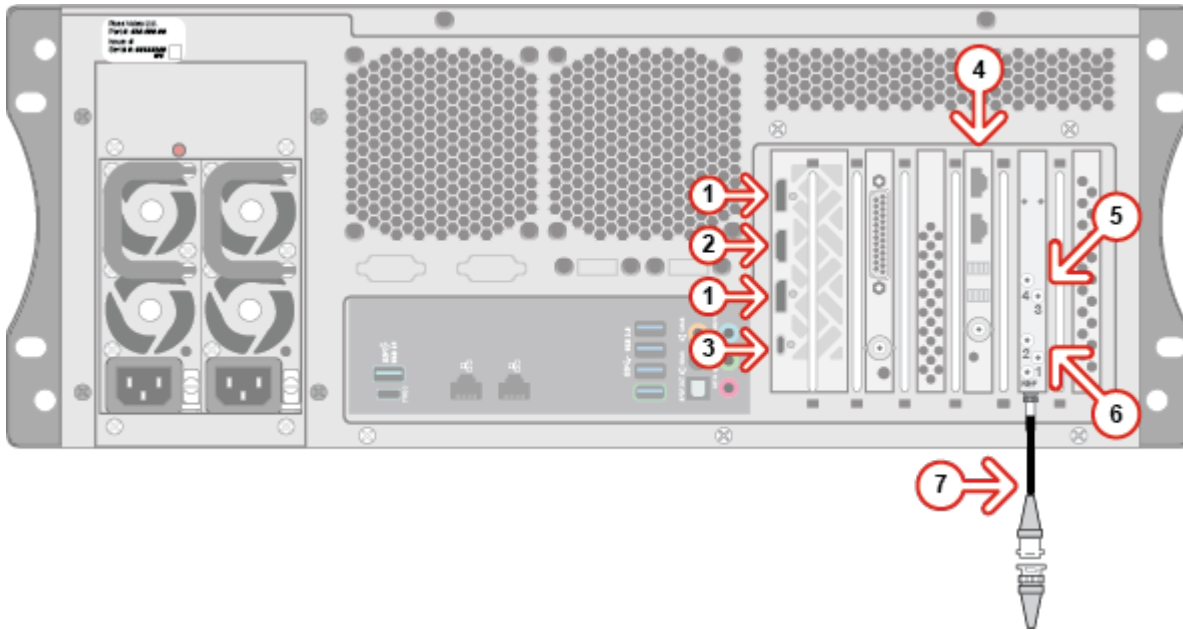

*Voyager 12G Rear Input/Output Connections*

- |  |  |
|--|--|
| <ol style="list-style-type: none"><li>1) <b>Display Ports</b> — Two Display Ports provide output for computer monitors. Ensure the correct display port to DVI adapters are used (DVI-D or DVI-I).</li><li>2) <b>HDMI Port</b> — One HDMI port provides output for a computer monitor.</li><li>3) <b>USB-C Port</b> — One USB-C port provides output for a computer monitor.</li><li>4) <b>nVidia Quadro Sync II</b> — Two Frame Lock connections for synchronizing multiple displays. Connect using <b>CAT-6 UTP Ethernet</b> cables.</li></ol> | <ol style="list-style-type: none"><li>5) <b>SDI HD-BNC</b> — Provides 12G SDI video output (Tx).<br/>Refer to <a href="#">Appendix B: Matrox 12G I/O Cables</a> <sup>58</sup> for further information.</li><li>6) <b>SDI HD-BNC</b> — Provides 12G SDI video input (Rx).<br/>Refer to <a href="#">Appendix B: Matrox 12G I/O Cables</a> <sup>58</sup> for further information.</li><li>7) <b>House Reference Genlock</b> — Provides an analog reference point.</li></ol> |
|--|--|

## Rear Peripheral Connections

The following diagram displays the peripheral connections. The peripheral connections are the same for each version of the Voyager system. Individual components are described in the legend below the diagram.

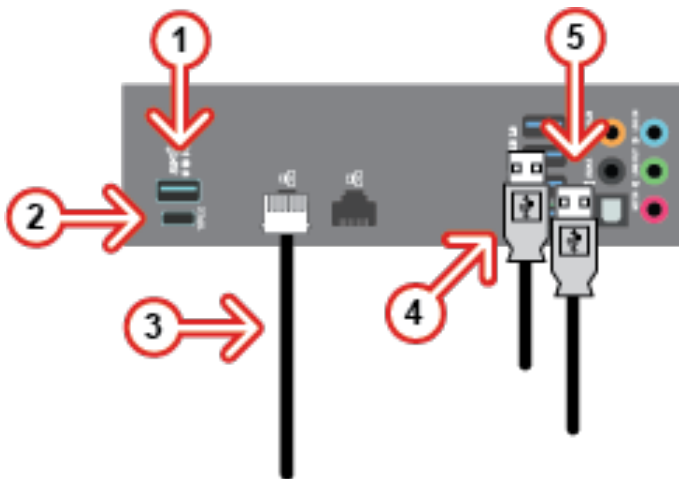

*Rear Peripheral Connections*

- |  |   |
|--|---|
| <p>1) <b>USB 3.1 Gen 1 Port</b> — Use this port to connect peripheral devices such as a keyboard or mouse to the system.</p> <p>This port can also be used to transfer media to and from USB drives.</p> <p>The port supports a maximum of 5 Gbit/s.</p> <p>★ Use of USB 3.1 certified cable and devices are required for USB 3.1 super-speed data rates.</p>        | <p>4) <b>USB 3.1 Gen 1 Port</b> — Use this port to connect peripheral devices such as a keyboard or mouse to the system.</p> <p>This port can also be used to transfer media to and from USB drives.</p> <p>The port supports a maximum of 5 Gbit/s.</p> <p>★ Use of USB 3.1 certified cable and devices are required for USB 3.1 super-speed data rates.</p> |
| <p>2) <b>USB 3.1 Gen 2 Type-C Port</b> — Use this port to connect peripheral devices such as a keyboard or mouse to the system.</p> <p>This port can also be used to transfer media to and from USB drives.</p> <p>The port supports a maximum of 5 Gbit/s.</p> <p>★ Use of USB 3.1 certified cable and devices are required for USB 3.1 super-speed data rates.</p> | <p>5) <b>USB 3.1 Gen 1 Port</b> — Use this port to connect peripheral devices such as a keyboard or mouse to the system.</p> <p>This port can also be used to transfer media to and from USB drives.</p> <p>The port supports a maximum of 5 Gbit/s.</p> <p>★ Use of USB 3.1 certified cable and devices are required for USB 3.1 super-speed data rates.</p> |
| <p>3) <b>Ethernet Ports</b> — Use one of these ports to connect the Voyager system to an internal network.</p> <p>These ports can be used for high-speed file transfer between the Voyager system and other computers on the internal network.</p>   |   |

## Power Supplies

The Voyager system has two identical hot-swappable power supply modules, located at the rear of the system on the left-hand side. Since the system requires a minimum of one power supply module to operate, only one module can be hot-swapped at a time. Each power supply module can be attached to a separate power circuit to provide redundancy in case of power failure.

The diagram below displays the parts of the power supply modules for the Voyager system. A description of the **A/C Power Cord Connection** is contained in the legend below the diagram.

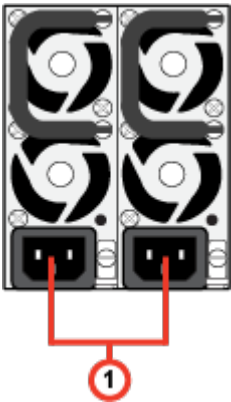

*Voyager System Power Supply Unit*

**A/C Power Cord Connection** — Connect the female end of the power cord to this connector, and the male end to a power circuit.

# Hardware Installation

This chapter provides installation instructions for the Voyager system hardware.

The topics described in this chapter are:

[Unpacking the Unit](#) <sup>12</sup>

[Installation Requirements](#) <sup>13</sup>

[Installing the System in an Equipment Rack](#) <sup>14</sup>

[Attaching the Cables](#) <sup>15</sup>

[Powering the System Up and Down](#) <sup>17</sup>

## Unpacking the Unit

Unpack the Voyager system from the received shipping container(s), and check the contents against the packing list to ensure all items are included. If any items are missing or damaged, contact your sales representative or Ross Video for assistance.

# Installation Requirements

Note the following installation requirements:

- **Elevated Operating Ambient** — If installed in a closed or multi-rack assembly, the operating ambient temperature of the rack environment may be greater than the room ambient. Therefore, consideration should be given to installing the equipment in an environment compatible with the maximum ambient temperature (T<sub>ma</sub>).

This equipment has an operating temperature range of 0° C to 35° C. The ambient temperature in the rack shall not exceed this temperature range.

- **Reduced Air Flow** — When installing the equipment in a rack, or as a desktop/tower, ensure that there is sufficient airflow to safely operate the equipment.

A minimum clearance of 0.25 in (6.35mm) on each side of the equipment must be maintained after installation in the rack.

- **Mechanical Loading** — Equipment must be evenly balanced when loaded into a rack to ensure the stability of the unit. Uneven mechanical loading is hazardous.
- **Circuit Overloading** — Check the nameplate rating of the equipment when connection to a supply circuit. Overloading the circuits may be hazardous to the over-current protection and supply wiring.
- **Reliable Earthing** — Maintain reliable earthing of rack and desktop/tower mounted equipment. Give particular to supplementary supply connections (e.g., use of power strips).

## Installing the System in an Equipment Rack

The Voyager system is designed to be rack mounted in a 19 inch (48.3 cm) wide equipment rack using the slide rails in the supplied rack mount kit.

- Rack Units — 4 RU
- Width — 16.9 inches (43.0 cm), 19 inches (48.3 cm) including handles
- Height — 6.9 inches (17.8 cm)
- Depth — 23.3 inches (59.2 cm), 24.4 inches (62 cm) including handles

The slide rails must be installed onto the Voyager system before it can be mounted in an equipment rack. Instructions for mounting the slide rails onto the Voyager system and equipment rack are included with the rack mount kit in the Voyager system shipping box.

★ Failure to install the Voyager system into an equipment rack using the supplied rack mount kit will void the Voyager system warranty.

# Attaching the Cables

Follow the instructions below to attach the cables to the Voyager system.

## To attach the cables to the Voyager system:

1. On the back of the Voyager system, connect the supplied line cords to the 2 power supplies, then plug the line cord(s) into a grounded outlet.

The power supplies are auto-sensing and can accept line voltages from 100 through 240 VAC. The Voyager system is equipped with 2 power supplies in a 1+1 redundant configuration. One power supply is required to run the Voyager system.

2. Plug the supplied USB keyboard into the upper **USB** port on the back of the unit.
3. Plug the supplied USB mouse into the lower **USB** port on the back of the unit.
4. Connect a monitor, customer supplied, to a **Display Port**.

Ensure the correct display port to DVI adapters are used (DVI-D or DVI-I). A monitor can also be connected to the USB-C port using a USB-C to display port adapter.

Additional monitors can be connected to any of the other 2 display ports to provide additional space for virtual preview channels, custom applications, web page capture, and more.

KVM extenders (customer supplied) are required when the Voyager System monitor, keyboard, and mouse are located remotely from the rack room.

5. Plug an Ethernet cable from the internal network into one of the **GigE Ethernet** ports.

Voyager systems can run standalone or accept a network connection if required to connect to a production network. Voyager systems also use this TCP/IP network connection to support the Smart GPI Feature.

6. Connect the GenLock signal cable to the **REF IN** BNC connector.

This connection is required to lock the Voyager system to the video timing of the facility. The Voyager system supports the following types of GenLock signal:

- **Analog BlackBurst** — a composite color video signal comprised of sync, color burst, and black video, also called "color black", "house sync" or "house black". Typically used as the house reference synchronization signal.
- **Tri-Level Sync** — a 3-level pulse synchronization signal used in high definition systems.

It is not necessary to terminate this connection if it is unused.

- For the Voyager base system, plug the GenLock signal cable into the breakout cable.
- For the Voyager IP system, plug the GenLock signal cable into the **REF IN** BNC connector below the SFP cages.
- For the Voyager 12G system, plug the GenLock signal cable into the **REF IN** BNC connector below the SDI HD-BNC spigots.

7. In the **AUDIO OUT** area, connect the audio output cables to the AES3id BNCs.

After the Voyager system is up and running, audio outputs can be assigned to each video channel.

The Voyager system provides AES3id 75 ohm BNC outputs. If AES3 110 ohm connections are required, optional GearLite adaptors are available from Ross Video.

For facilities requiring analog outputs, additional outboard analog to digital conversion equipment is also available from Ross Video.

8. The video connections are different, depending on the Voyager system.

For the Voyager base system, connect the 9 HD-BNC video I/O cables to their required destination (see the Voyager Quick Start Guide for information about configuring the **Key** and **Fill** for the HD-BNC connectors). The default configuration is displayed in the table in the section, [Appendix A: Matrox I/O Cables](#)<sup>[56]</sup>. Not all HD-BNC connectors will be active depending on the Voyager software edition.

If you are upgrading your Frontier system to Voyager software, connect the 9 HD-BNC video I/O cables to their required destination, as shown in [Appendix C: AJA Corvid 88 I/O Cables](#)<sup>[59]</sup>.

For the Voyager 12G system, connect the HD-BNC video I/O cables to their required destination (see the Voyager User Guide or Help file for information about configuring the **Key** and **Fill** for the HD-BNC connectors).

For the Voyager IP system, insert pluggable SFP connectors into the SFP cages and attach the networking cables to the connectors.

Voyager systems provide SD/HD-SDI outputs. If your facility requires analog outputs, additional outboard digital to analog conversion equipment is available from Ross Video.

## Powering the System Up and Down

This section describes how to power the system up and how to shut it down.

### Powering Up the System

Once the cables are attached and the system has been connected to a power source, you can power up the Voyager system.

#### **To power up the system:**

1. Open the front door of the Voyager system.
2. Press the **Power** button to begin the boot procedure.
3. Close the front door to protect the Voyager system from dust.

### Powering Down the System

Whenever the Voyager system needs to be powered down, use the following procedure:

#### **To power down the system:**

1. Log on to the Voyager system.
2. From the **Start** menu, select **Shut down**.

The Voyager system shuts down.

# Hard Drive Maintenance

Voyager utilizes a software-based RAID system in conjunction with an ICH10 chipset on the system motherboard. This setup relies on the Windows operating system and host processor to perform all of the RAID functionality.



**Warning** — *Always use proper Windows shutdown procedure. NEVER HARD POWER OFF THE UNIT. Hard shutdown may cause failures in the RAID, taking one or more drives offline.*

The topics described in this chapter are:

[MegaRAID Storage Manager](#)<sup>19</sup>

[RAID Array Consistency Check and Repair](#)<sup>21</sup>

[RAID Array Drive Replacement](#)<sup>22</sup>

# MegaRAID Storage Manager

The MegaRAID Storage Manager is used to manage, maintain, and monitor the Voyager server RAID array.

Use the following procedure to open the MegaRAID Storage Manager.

## To open the MegaRAID Storage Manager:

1. Log in to the Voyager server using the following (no password):
  - **Username** — Voyager
  - **Password** — beyondinfinity
2. In the Windows start menu, select **MegaRAID Storage Manager > StartupUI**.

The **MegaRAID Storage Manager Server Details** window opens.

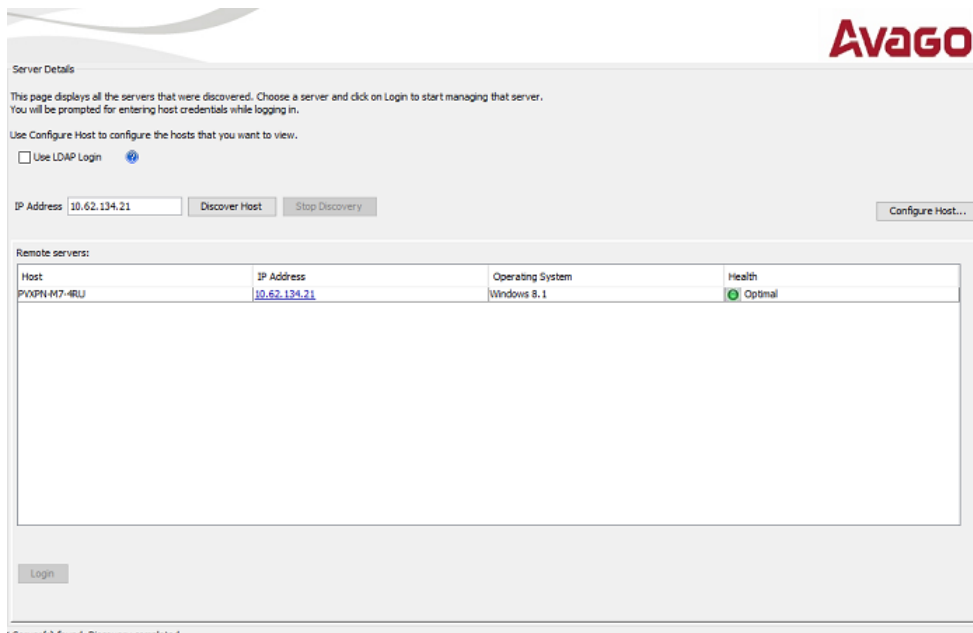

*Storage Manager - Server Details*

3. Double-click the server under **Host** labeled **Voyager**.

The **Enter User Name & Password** dialog opens.

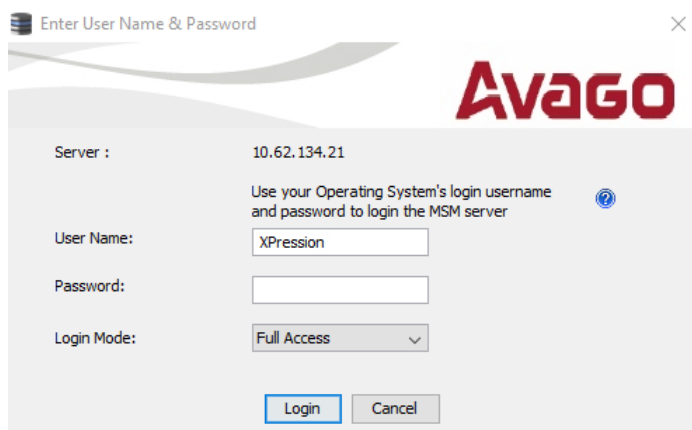

*Storage Manager - Login*

4. Enter the following:

**Username** — Voyager

**Password** — beyondinfinity

5. From the **Login Mode** list, select **Full Access**.

6. Select **Login**.

The **MegaRAID Storage Manager** opens.

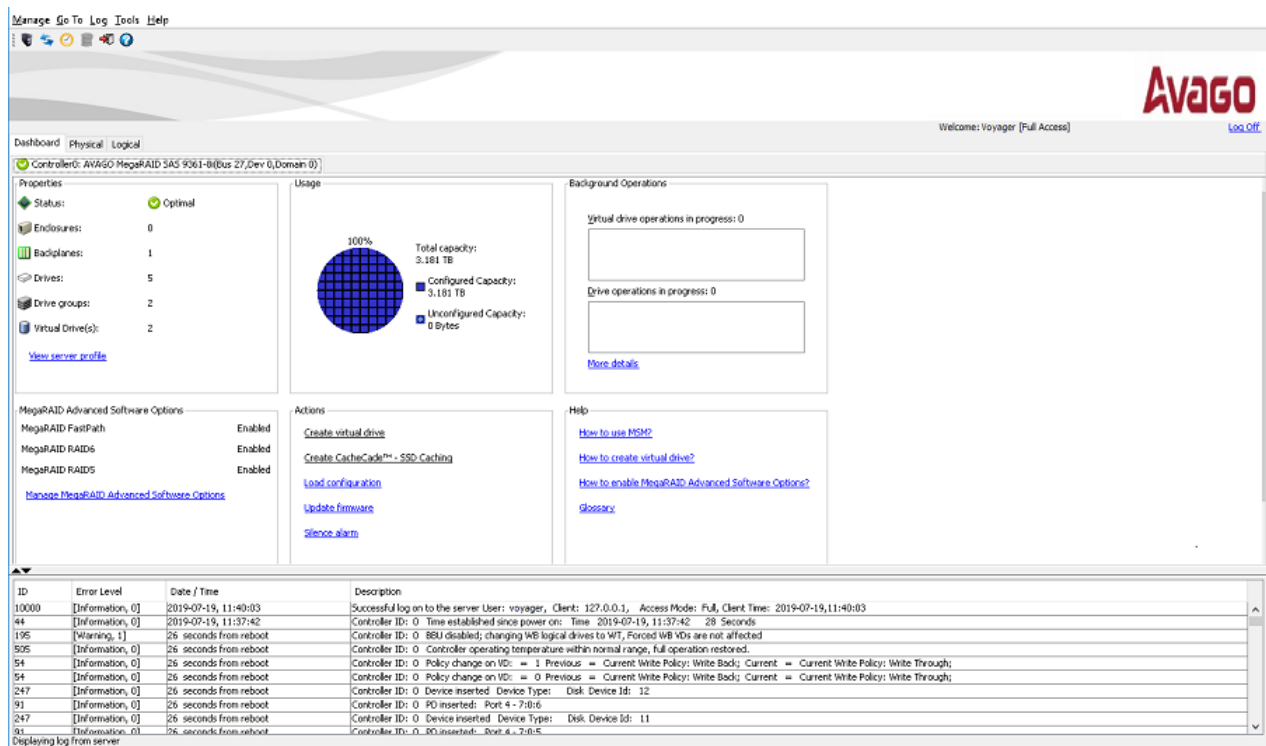

*Storage Manager - Dashboard Tab*

# RAID Array Consistency Check

It is important to check the Voyager RAID array for consistency. Consistency checks ensure that all drives are functioning and that damaged sections are repaired. It is recommended that consistency checks are performed on a weekly basis.

★ Consistency checks can affect the performance of the Voyager server. Consistency checks should only be performed or scheduled when Voyager is not in use.

## To run a consistency check on the Voyager RAID array:

1. Open the **MegaRAID Storage Manager**.
2. In the **MegaRAID Storage Manager**, from the menu bar, select **Manage > Check Consistency**.

The **Group Consistency Check** dialog opens.

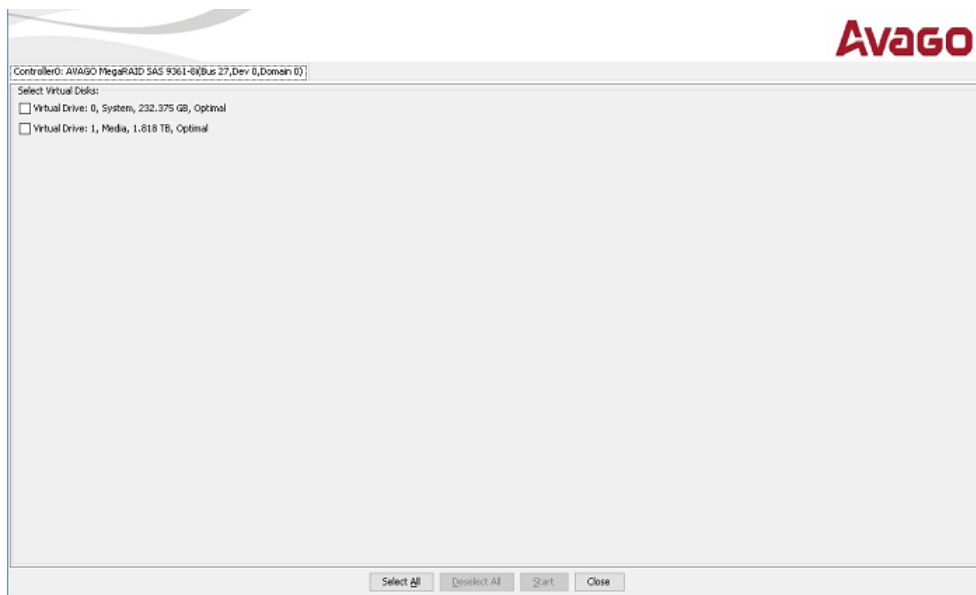

*Storage Manager - Group Consistency Check*

3. From the **Select Virtual Disks** section, select the checkboxes of the virtual drives to check for consistency, or select the **Select All** button to select all of the virtual drives.
4. Select **Start**.

The consistency check starts.

## For More Information on...

- opening the MegaRAID storage manager, refer to the procedure [To open the MegaRAID Storage Manager](#) <sup>19</sup>.

# RAID Array Drive Replacement

If a single drive fails in the Voyager RAID array, the system is protected from data loss. The failed drive must be replaced as soon as possible, and the data on the failed drive must be rebuilt on a new drive to restore the system to fault tolerance.

In the MegaRAID Storage Manager, failed virtual drives are highlighted by a yellow LED icon (🟡) displayed to the right of the virtual drive icon. The yellow LED icon indicates that the virtual drive is in a degraded state; the data is still safe, but data could be lost if another drive fails.

When a new, unconfigured drive is inserted to repair the failed virtual drive, the new drive is highlighted by a red LED icon (🔴) displayed to the right of the drive icon.

Rebuilding a drive consumes bandwidth on the Voyager server and is ideally done during off hours, or when the server has a low workload.

- ★ To prevent accidental data loss, back up all data before replacing a drive in the Voyager RAID array.
- ★ Depending on the server workload, rebuilding a drive could take up to three hours to complete.

## To rebuild a failed drive used by a virtual drive:

1. Open the MegaRAID Storage Manager.

For instructions on opening the MegaRaid Storage Manager, see [To open the MegaRAID Storage Manager](#).

2. Before beginning the replacement, in the **Physical** tab, right-click the **Controller** and in the context menu, select **Silence alarm**.

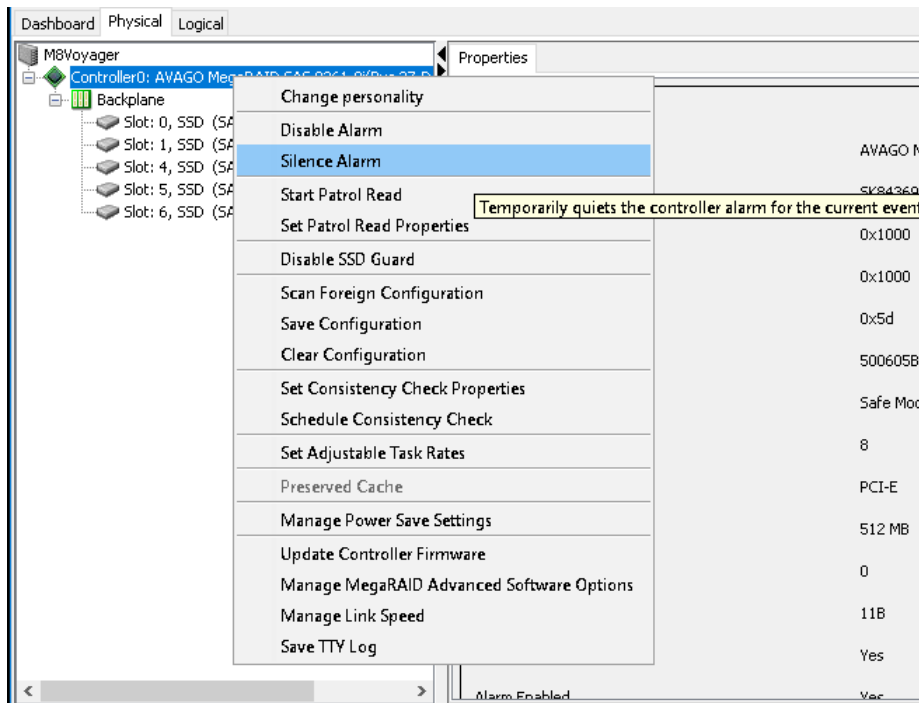

Storage Manager - Silence Alarm

3. Select the **Logical** tab.

The drives contained in the Voyager RAID array are listed in the **Logical** tab.

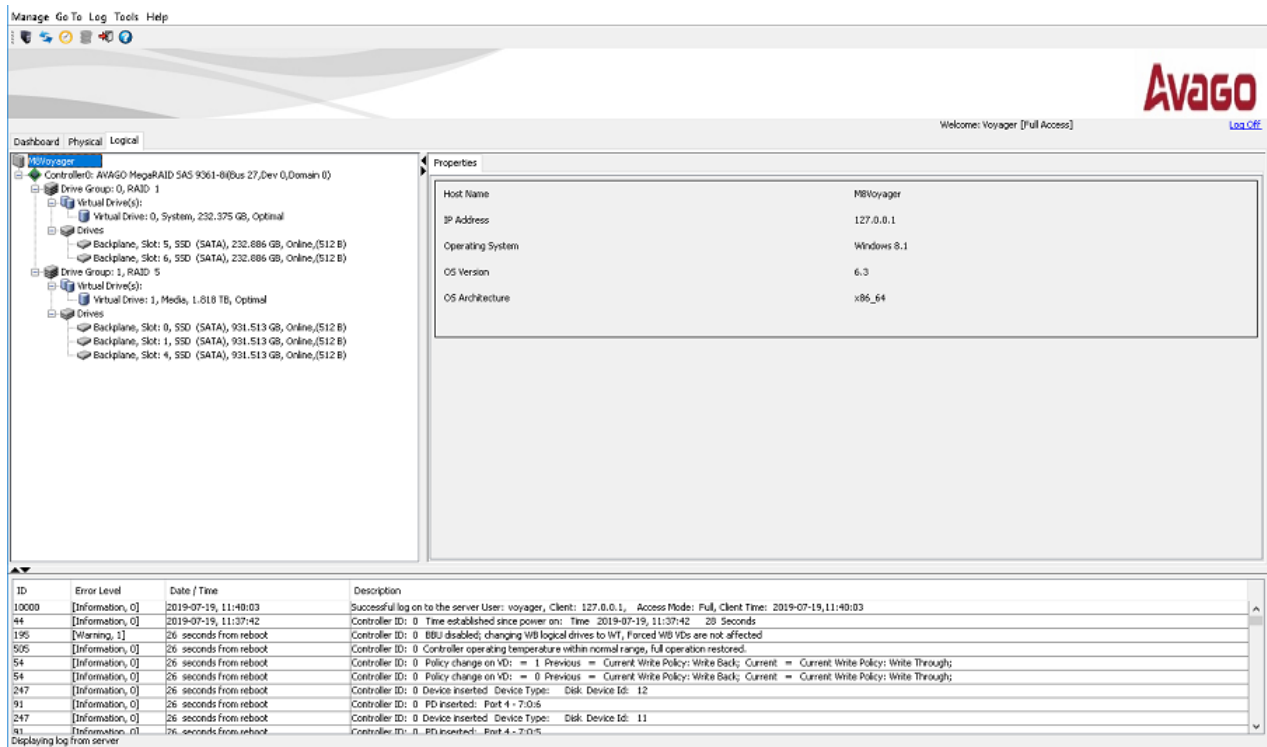

*Storage Manager - Logical Tab*

Unconfigured drives are highlighted by a red LED icon (●) displayed to the right of the drive icon.

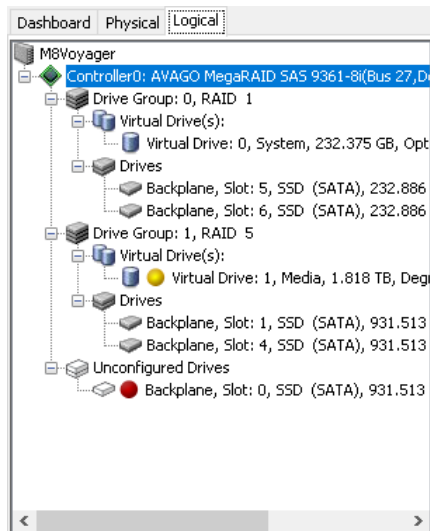

*Storage Manager - Drive Offline*

- Referring to the diagram below, remove the indicated failed drive and insert a new replacement drive of the same size or greater.

Do not use a smaller drive.

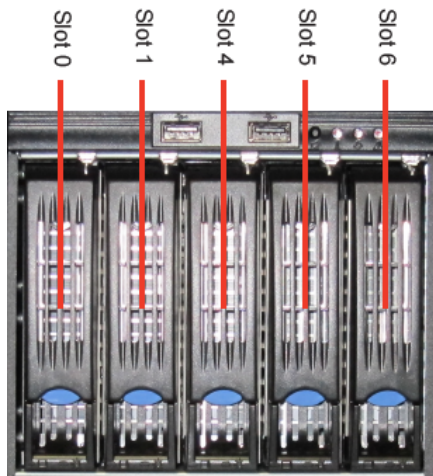

Media and System Drives

For instructions on removing and replacing drives, refer to the section [Replacing a System Drive](#)<sup>[27]</sup>.

- Once the new drive is in place, in the **Physical** tab, under **Unconfigured Drives**, right-click the new drive and select **Change to Unconfigured Good**.
- Right-click the drive again and select **Replace Missing Drive**.

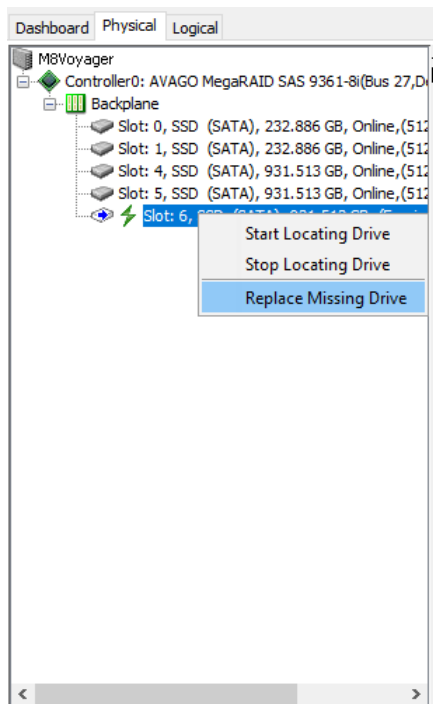

Storage Manager - Replace Missing Drive

7. In the **Confirmation** dialog, select **OK**.

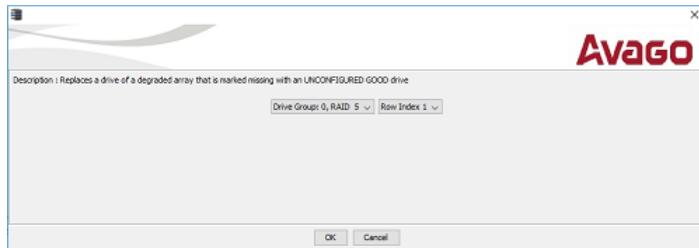

*Confirmation Dialog - Replace Missing Drive*

8. Right-click the drive again and select **Make Drive Online**.

A confirmation dialog opens.

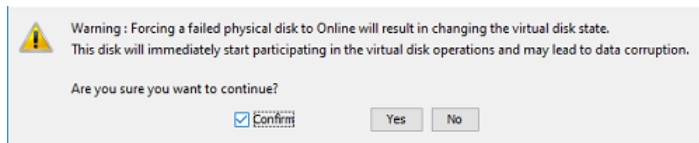

*Confirmation Dialog - Putting Drive Online*

9. Select the **Confirm** checkbox and then select **Yes**.

### To view the build progress:

1. Select **Manage > Show Progress** to monitor the rebuild progress.

The **Group Show Progress** window opens.

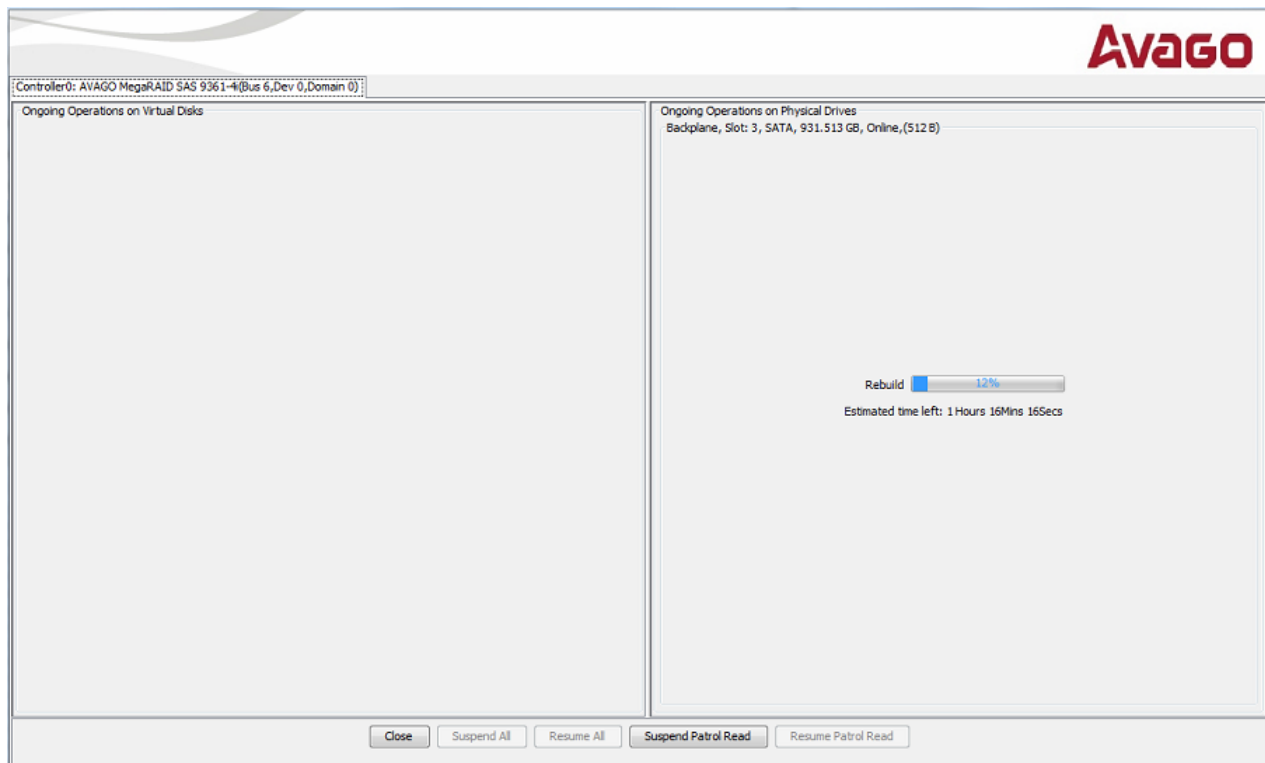

*Group Show Progress*

2. Select **Close** when the process is complete.

# Hardware Maintenance

This chapter provides information on maintaining the Voyager base system.

The topics described in this chapter are:

[Replacing a System Drive](#) 

[Removing and Reinstalling the Top Panel](#) 

[Replacing Cooling Fans](#) 

[Replacing Power Supplies](#) 



**Caution** — *Danger of Explosion if the system lithium battery is incorrectly replaced. Replace only with the same or equivalent type of battery recommended by the manufacturer. Dispose of used batteries according to the manufacturer's instructions by a qualified service person.*

## Replacing a System Drive

The Voyager system drives are capable of being hot-swapped while the system is running. Keep in mind the following when hot-swapping system drives:

- ★ Only one system drive can be removed at any time.



**Protective Earth** — *Static discharge can cause serious damage to sensitive devices. Avoid handling any hard drive in high static environments such as carpeted areas and when synthetic fiber clothing is worn. Touch the chassis to dissipate static charge before removing hard drives from the system, and exercise proper grounding precautions when working around the Voyager system.*

This section describes how to remove and replace a system drive.

### To remove a system drive from the Voyager system:

1. Open the front door of the Voyager system.



2. On the front of the drive sled, push the blue release button up to release the black handle.



The drive sled is released from the drive bay.

3. Gently pull the drive sled out of the drive bay using the black handle.

As the drive sled is pulled from the drive bay, place a hand underneath it for support.

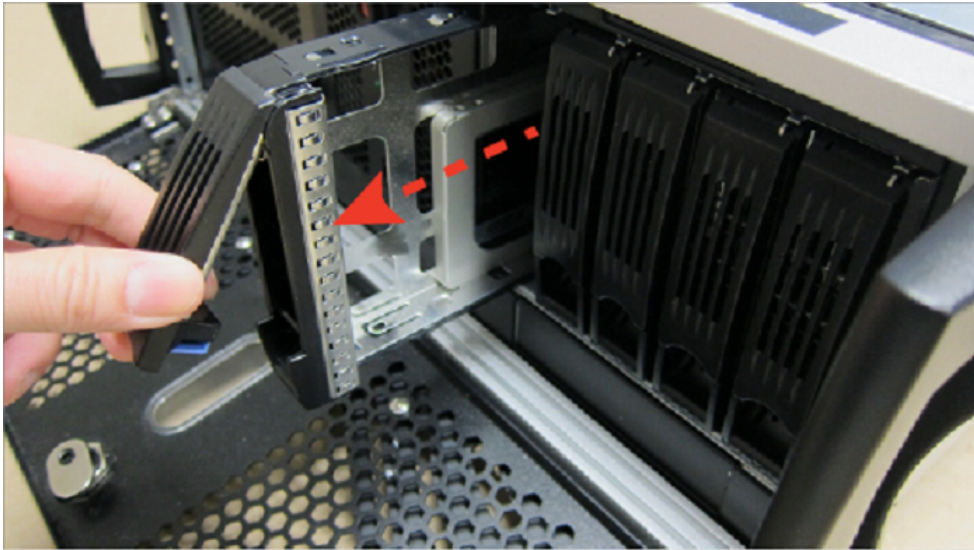

4. Using a Phillips head screwdriver, remove the screws from the drive sled.

There are 4 screws in total.



5. Gently lift the drive sled off the drive, placing it to one side on a flat surface.

The drive sled is now empty and ready for the installation of a new drive.

## To replace a system drive:

1. Insert the new drive into the sled with the label facing downwards and the connectors at the open end of the sled.



2. Turn the sled over and align the four screw holes on the drive with the screw holes on the sides of the sled.
3. Insert and tighten the Phillips head screws in the screw holes.

There are 2 screws in total.



The drive is now ready to be re-inserted into the Voyager system.

4. Use the drive bay map below to locate the drive bay in the Voyager system that matches the drive number on the drive sled being returned to the Voyager system.

Slots 0 and 1 are system drives and Slots 4, 5, and 6 are media drives.

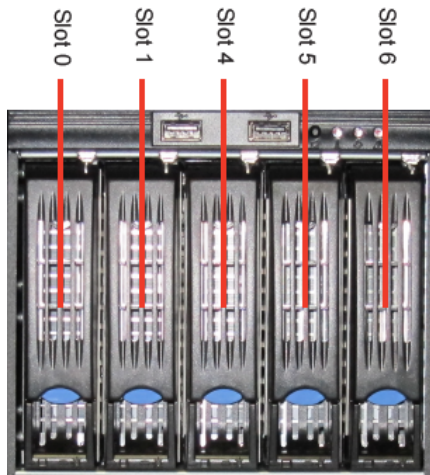

5. Align the drive sled so that the rear connector area is at the bottom of the drive sled and facing the correct drive bay for the drive sled.
6. On the front of the drive sled, push the blue release button up to release the black handle.
7. Slide the drive sled into the drive bay.

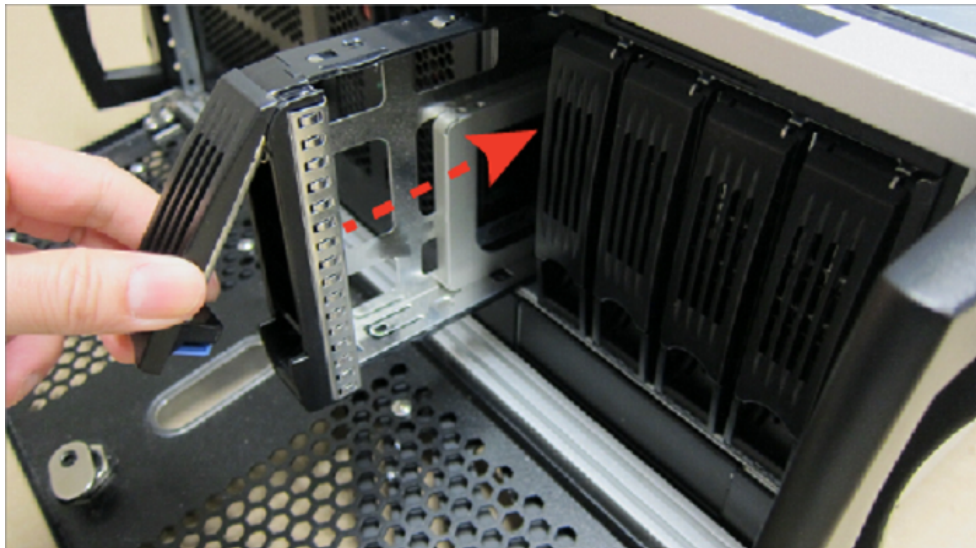

8. Push the drive sled firmly into place.



9. Close the black handle flush to the drive sled face to lock the drive into the drive bay.

The blue LED beneath the drive sled should activate to indicate that the drive is connected to the system.

Refer to [Hard Drive Maintenance](#) <sup>18</sup> for further information.

## Removing and Reinstalling the Top Panel

The top panel of the Voyager system can be removed to gain access to internal components such as fans, cards, and the USB security dongle.



**Caution** — *Do not operate the Voyager system with the top panel removed.*

This section describes how to remove and replace the top panel of the Voyager system.

### To remove the top panel of the Voyager system:

1. Shut down the Voyager system, remove all cabling, remove the system from the equipment rack, and place the system on a flat, non-slip surface.
2. Remove the 2 thumbscrews at the back of the Voyager system.

Set the 2 thumbscrews aside, as they will be needed to replace the top panel.



3. Gently pull the top panel back towards the rear of the unit, creating a gap between the top panel of the unit and the front of the chassis.

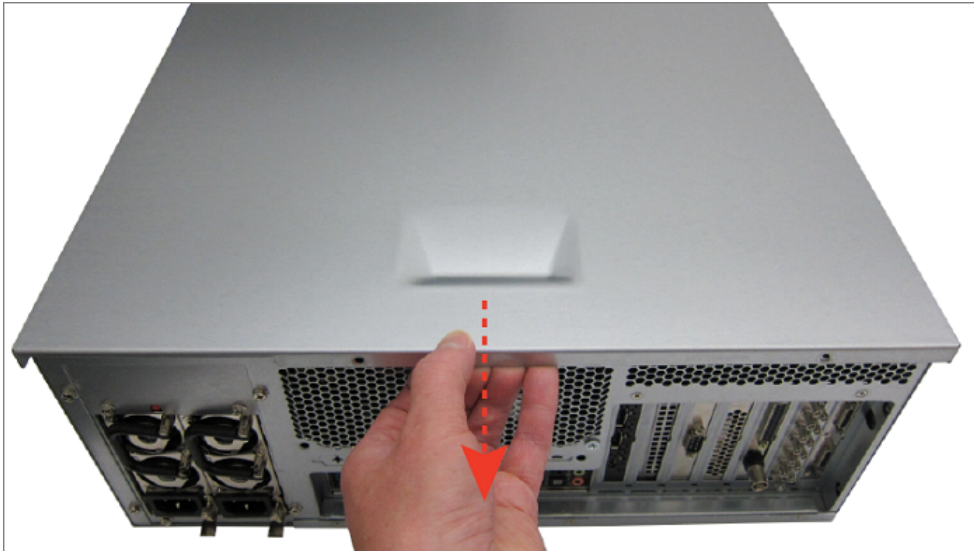

4. Lift the top panel off the chassis.



### **To reinstall the top panel**

1. Place the top panel onto the top of the Voyager system as follows:
  - Face the sides of the top panel down around the sides of the system.
  - Line up the 4 nubs on the inside of the sides of the top panel with the L-shaped grooves on the sides of the system.

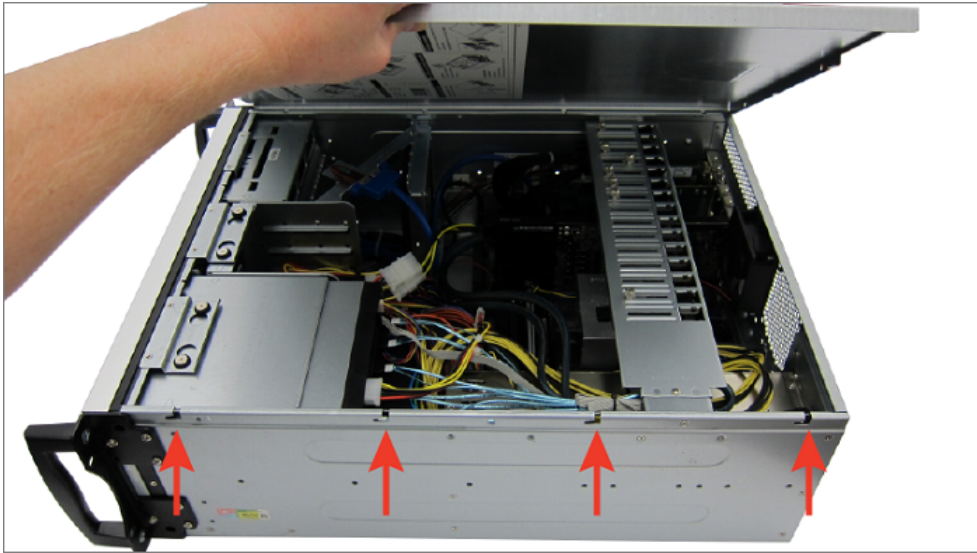

2. Gently slide the top panel into place, until a clicking noise is heard and the top panel is flush to the front top of the Voyager system.

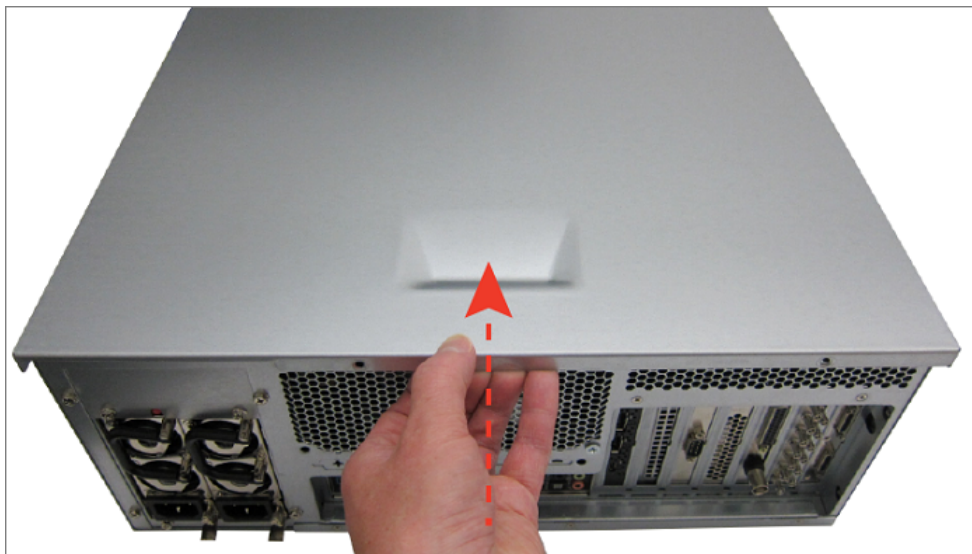

3. Insert and tighten the 2 thumbscrews into the back of the Voyager system.



## Replacing Cooling Fans

The Voyager system has five cooling fans. There are four cooling fans in the Voyager system that can be replaced if they fail:

- [the front chassis fan](#) <sup>37</sup>
- [the inside chassis fan](#) <sup>46</sup>
- [the rear chassis fan](#) <sup>48</sup>
- [the system drive fan](#) <sup>50</sup>

There are two fans on the CPU cooler. To replace the CPU cooler fans, please contact [Ross Video Technical Support](#) for assistance.

★ The Voyager system must be shut down when replacing the cooling fans.



**Protective Earth** — *Static discharge can cause serious damage to sensitive devices. Avoid handling any hard drive in high static environments such as carpeted areas and when synthetic fiber clothing is worn. Touch the chassis to dissipate static charge before removing hard drives from the system, and exercise proper grounding precautions when working around the Voyager system.*

If a fan fails, the fan failure alarm will trigger. Refer to the section [Power LED Area](#) <sup>5</sup> for further information on Voyager system hardware alarms.

## Replacing the Front Chassis Fan

This section describes how to remove and reinstall the front chassis fan.

### To remove the front chassis fan:

1. Make sure the Voyager system is shut down.
2. Remove the top panel from the Voyager system.

Refer to the section [Removing and Reinstalling the Top Panel](#) <sup>32</sup> for instructions.

3. Remove the retaining bar screw.

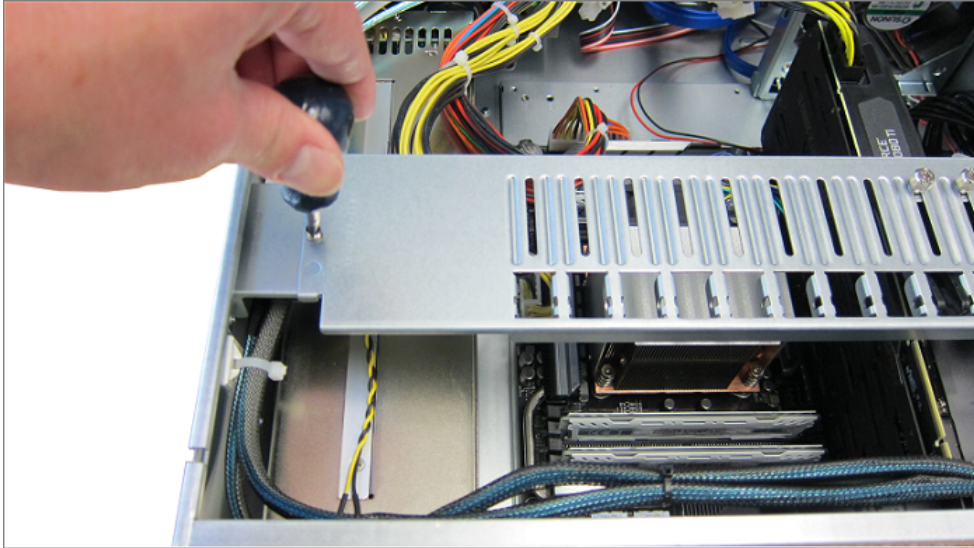

4. Remove the retaining bar.

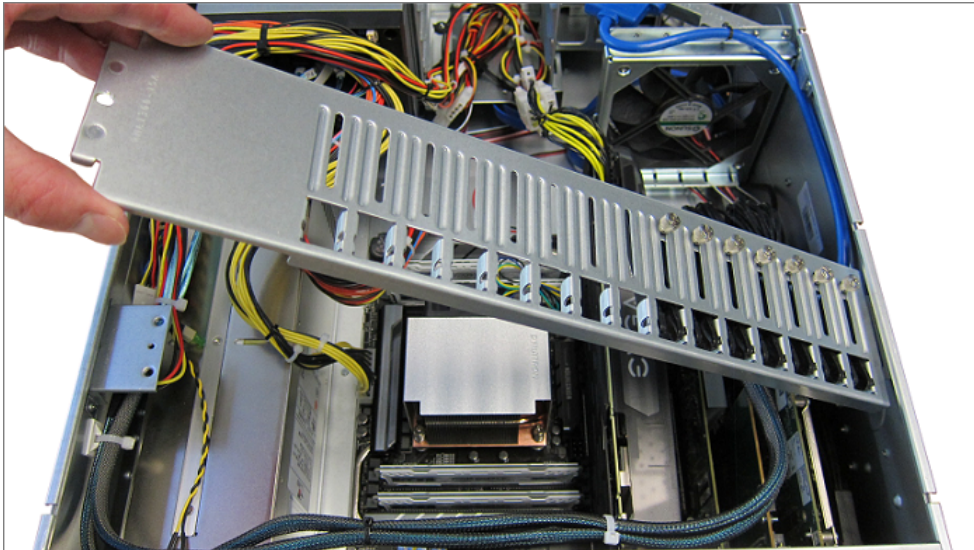

5. Remove the screw securing the Geforce RTX 2080 TI card and then remove the card itself.

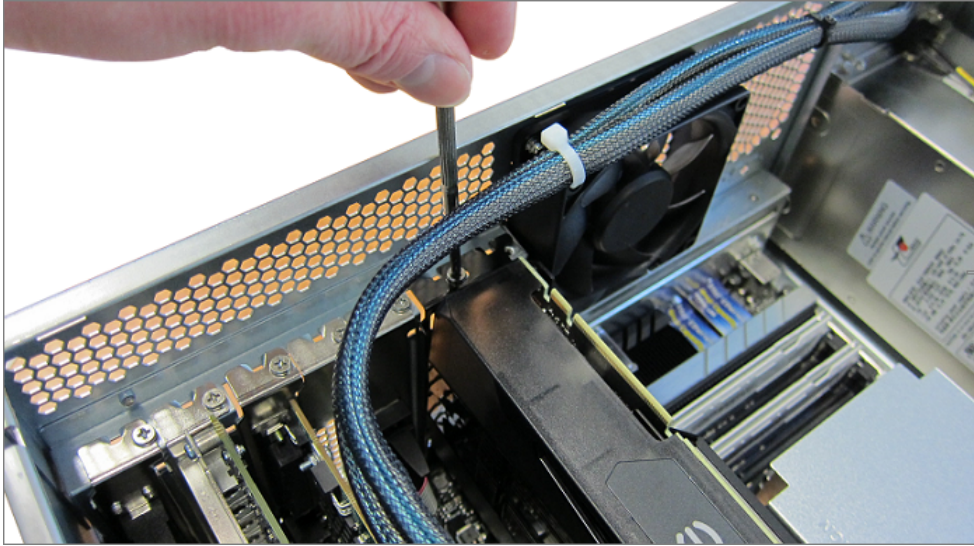

6. Disconnect the front chassis fan power supply wire.

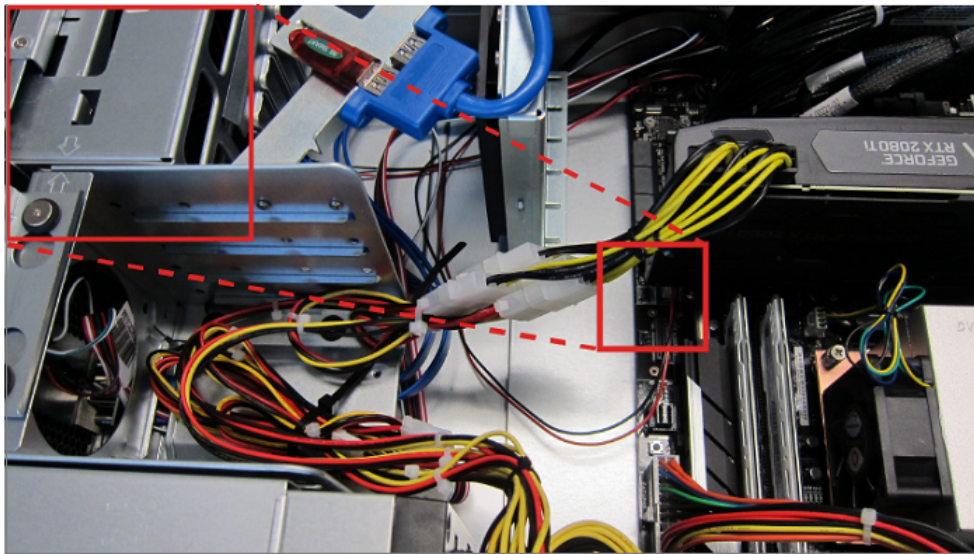

7. Open the front door of the Voyager system.



8. Unscrew the 2 thumb screws on the front fan cage.



9. Remove the front fan cage from the Voyager system.



10. Using a Phillips head screwdriver, remove the screws from the fan cage.  
There are 4 screws in total.

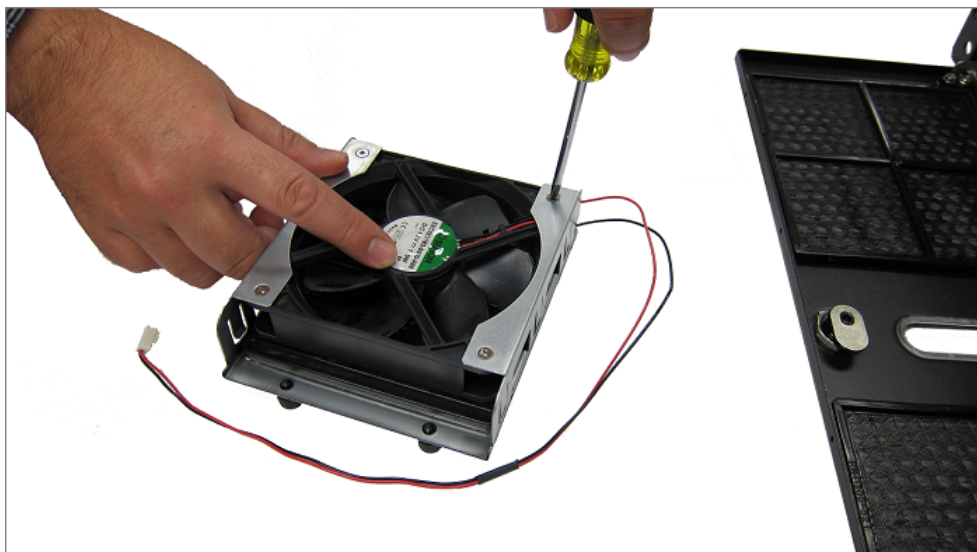

11.Remove the fan from the fan cage.

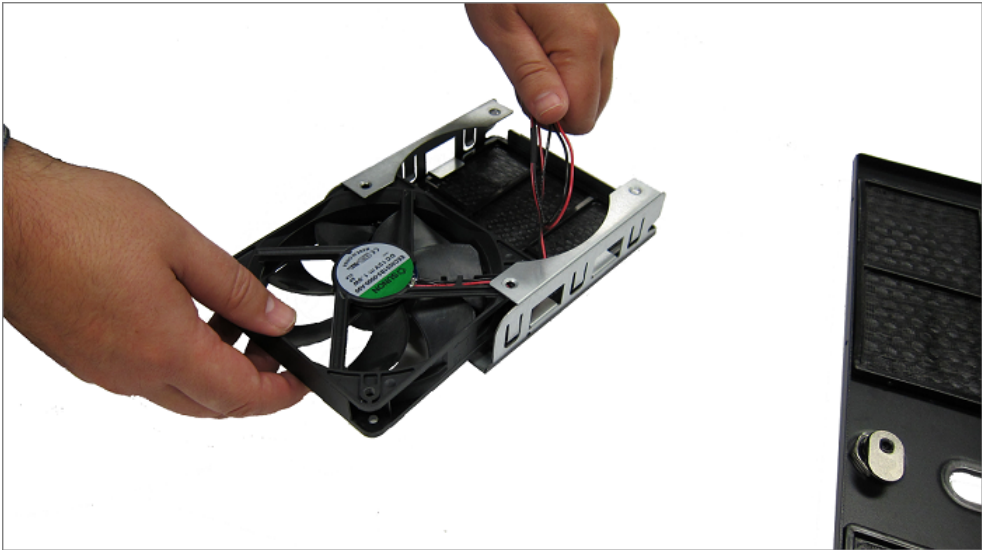

**To install the front chassis fan:**

1. Insert the new fan into the fan cage.

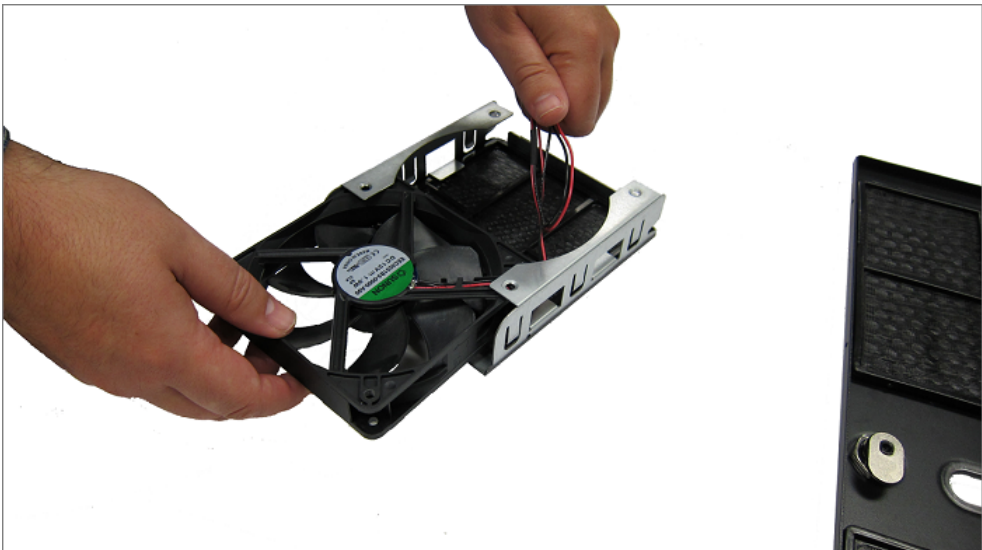

2. Insert and tighten the Phillips head screws in the screw holes.

There are 4 screws in total.

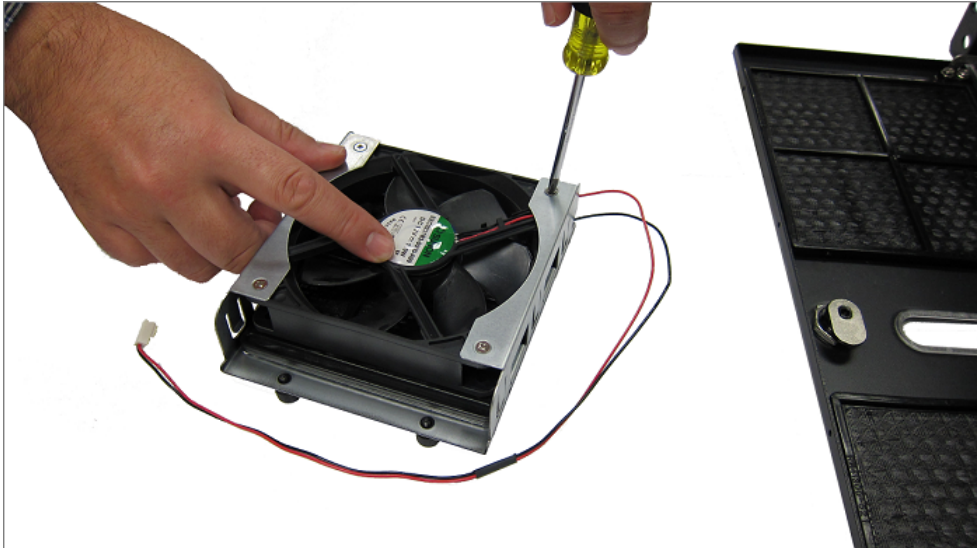

3. Insert the front fan cage in the Voyager system with the fan wire inside the Voyager chassis.



4. Tighten the two thumb screws on the front fan cage.



5. Close the front door of the Voyager system.



6. Connect the front chassis fan power supply wire.

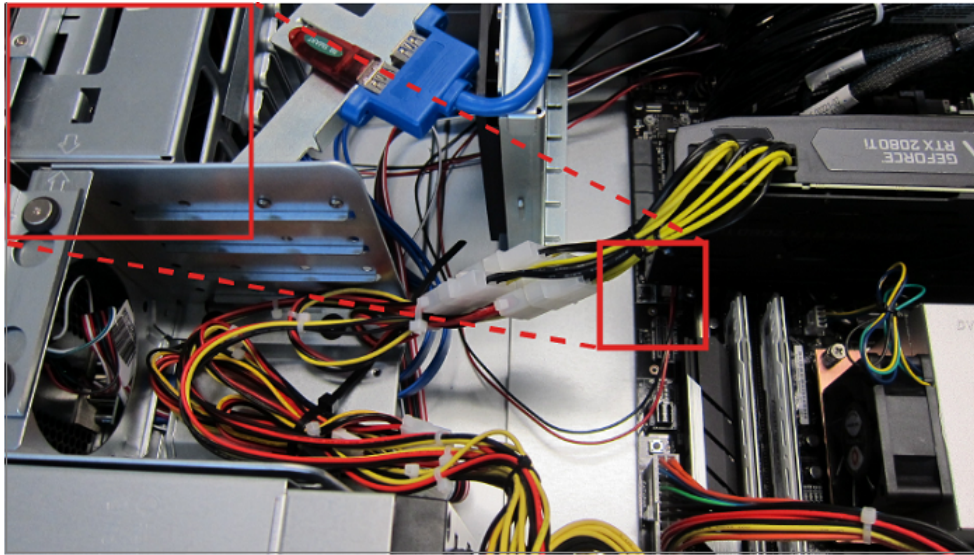

7. Replace the Geforce RTX 2080 TI card and secure the card with the screw.

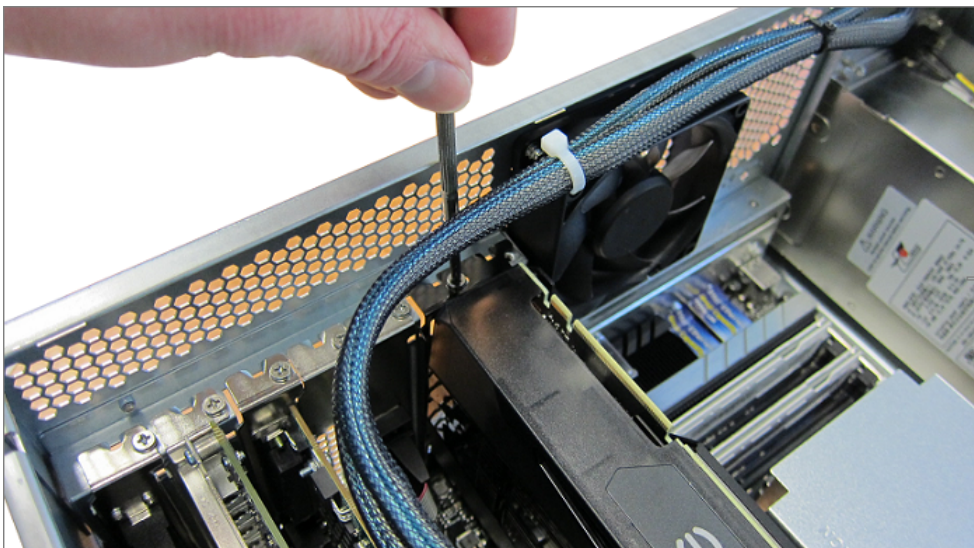

8. Put the retaining bar back in place.

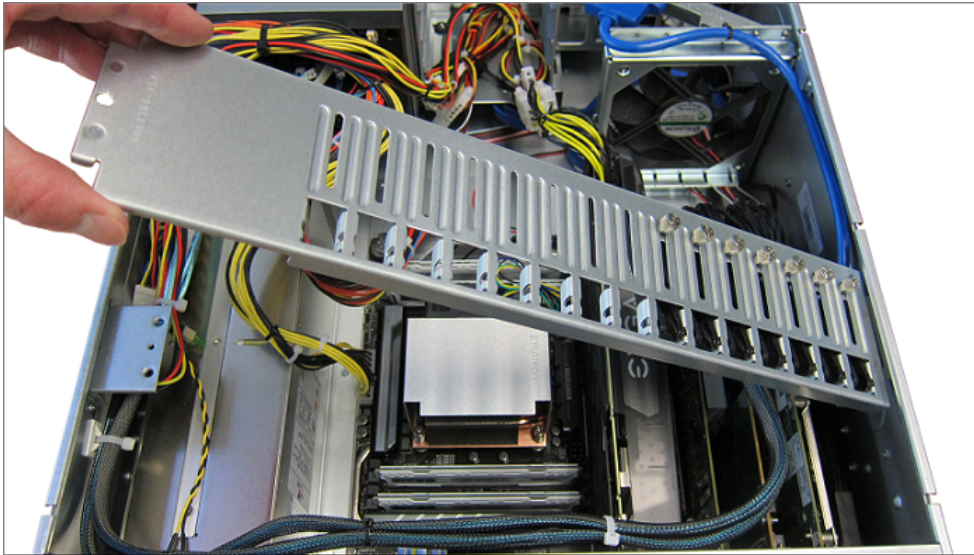

9. Secure the retaining bar with the screw.

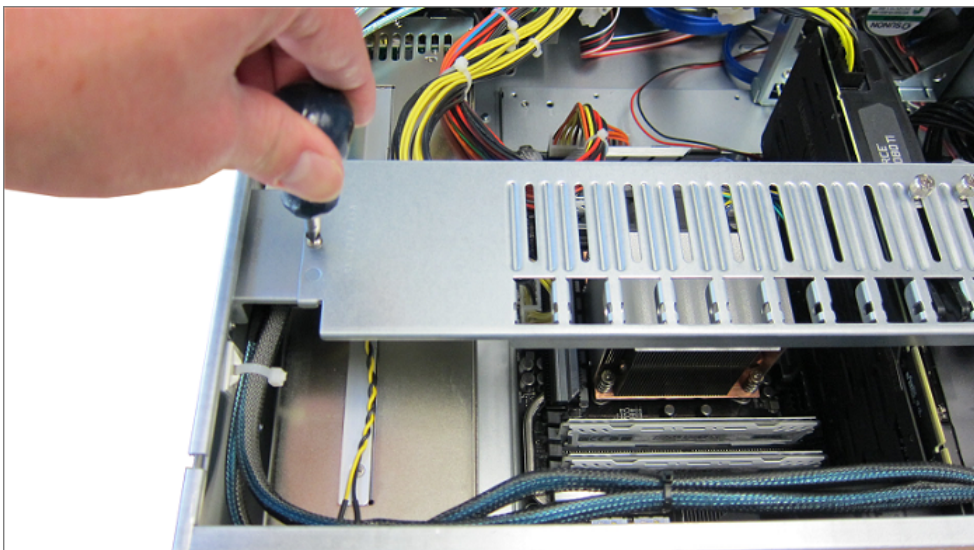

10. Replace the top panel.

Refer to the section [Removing and Reinstalling the Top Panel](#) <sup>32</sup> for instructions.

## Replacing the Inside Chassis Fan

This section describes how to remove and reinstall the inside chassis fan.

### To remove the inside chassis fan:

1. Make sure the Voyager system is shut down.
2. Remove the top panel from the Voyager system.

Refer to the section [Removing and Reinstalling the Top Panel](#) <sup>32</sup> for instructions.

3. Disconnect the inside chassis fan power supply wire.

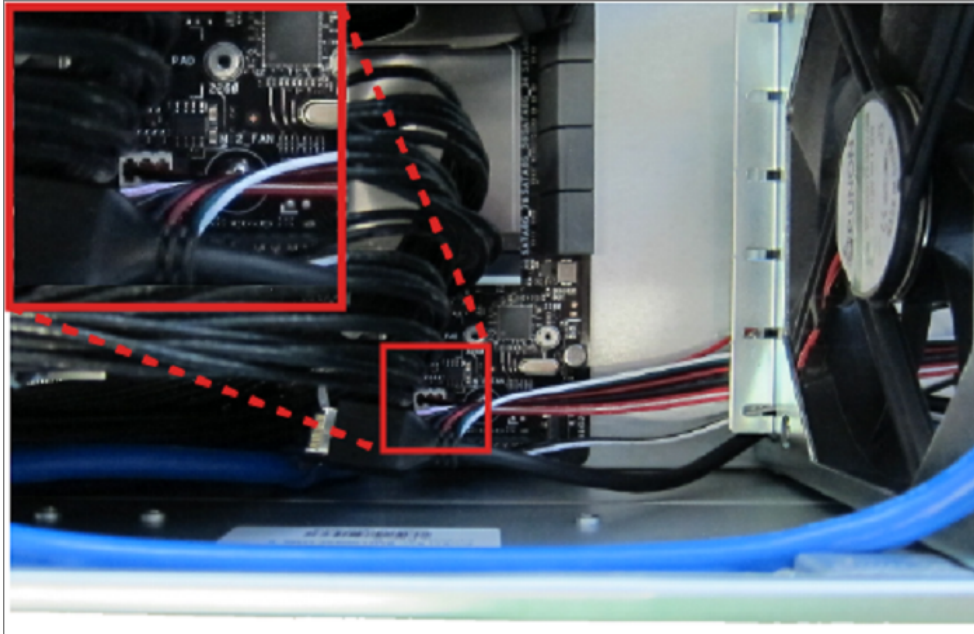

4. Using a Phillips head screwdriver, remove the screws from the fan cage.

There are 4 screws in total.

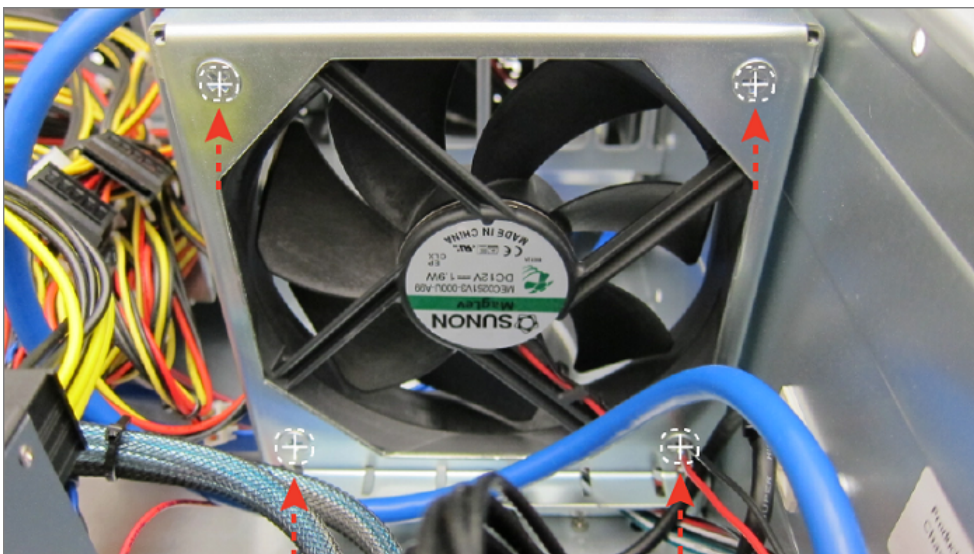

5. Remove the fan from the fan cage.

**To install the inside chassis fan:**

1. Insert the fan in the fan cage.
2. Using a Phillips head screwdriver, insert and tighten the screws in the fan cage.
3. There are 4 screws in total.

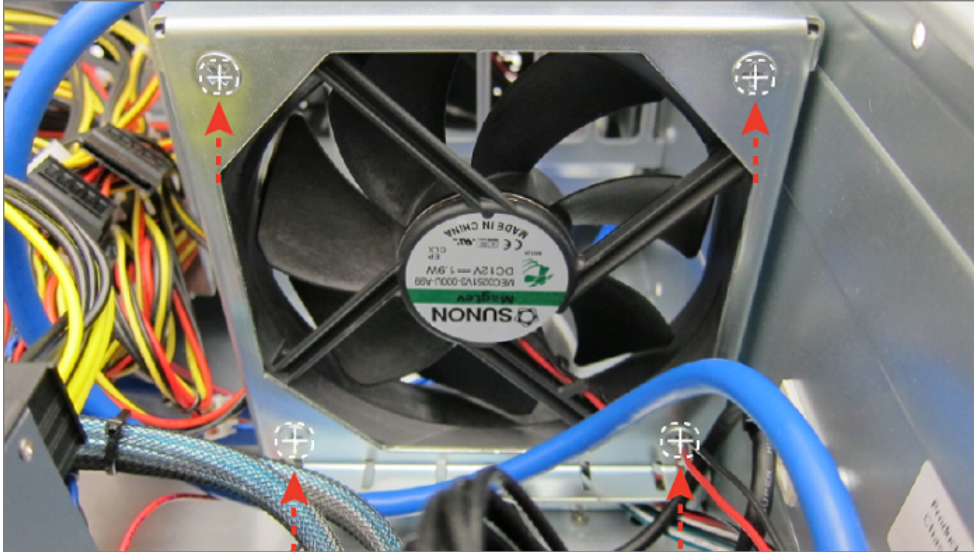

4. Connect the middle chassis fan power supply wire.

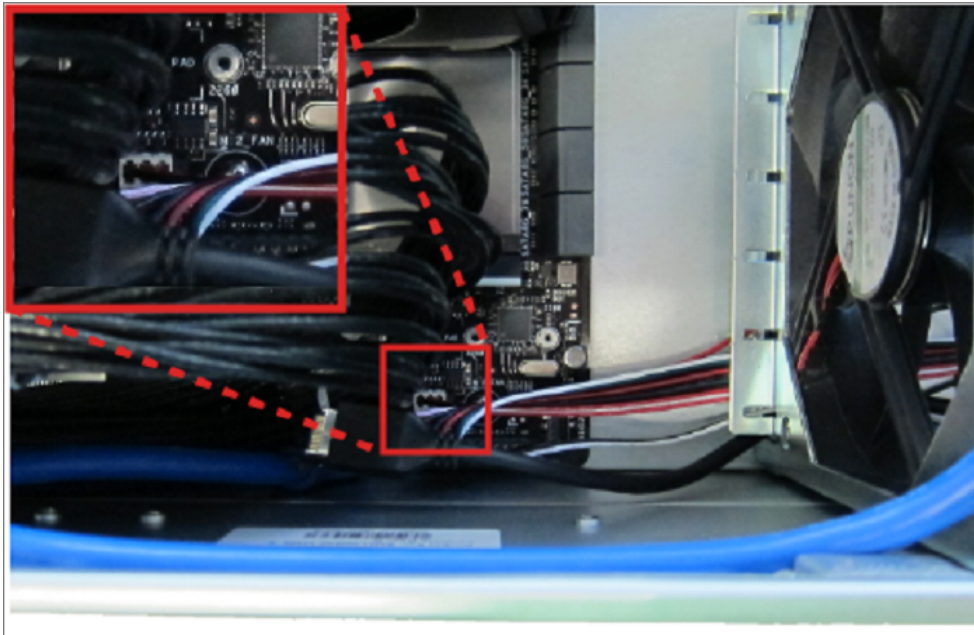

5. Replace the top panel.  
Refer to the section [Removing and Reinstalling the Top Panel](#) <sup>32</sup> for instructions.

## Replacing the Rear Chassis Fan

This section describes how to remove and reinstall the rear chassis fan.

### To remove the rear chassis fan:

1. Make sure the Voyager system is shut down.
2. Remove the top panel from the Voyager system.  
Refer to the section [Removing and Reinstalling the Top Panel](#) for instructions.
3. Disconnect the rear chassis fan power supply wire.

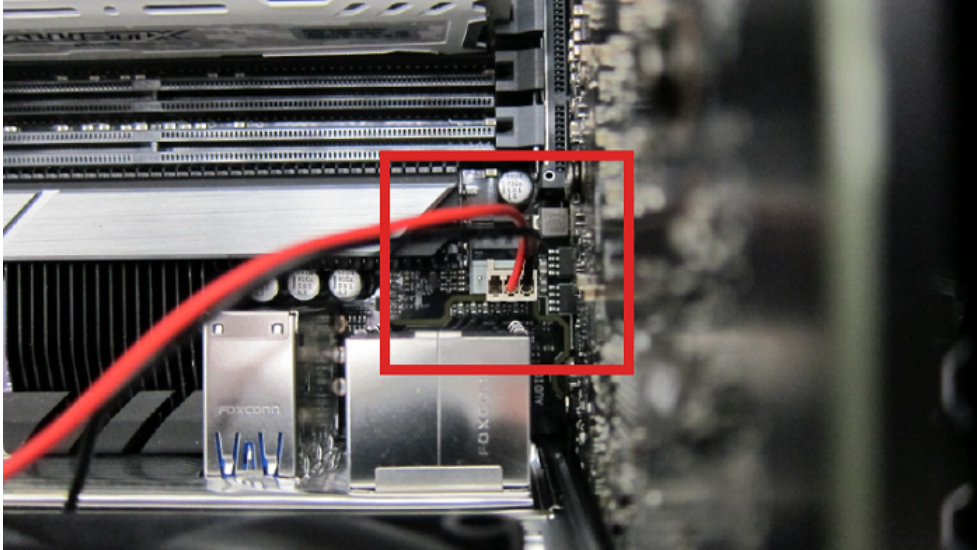

4. At the rear of the chassis, use a Phillips head screwdriver to remove the screws from the fan cage. There are 4 screws in total.

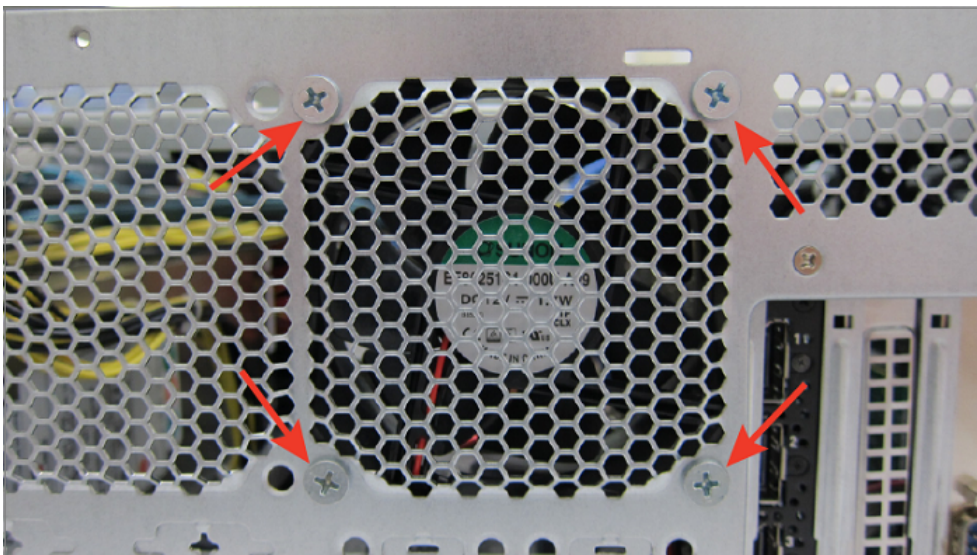

5. Remove the fan.

### To install the rear chassis fan:

1. Insert the fan.
2. At the rear of the chassis, use a Phillips head screwdriver to insert and tighten the screws in the fan cage.

There are 4 screws in total.

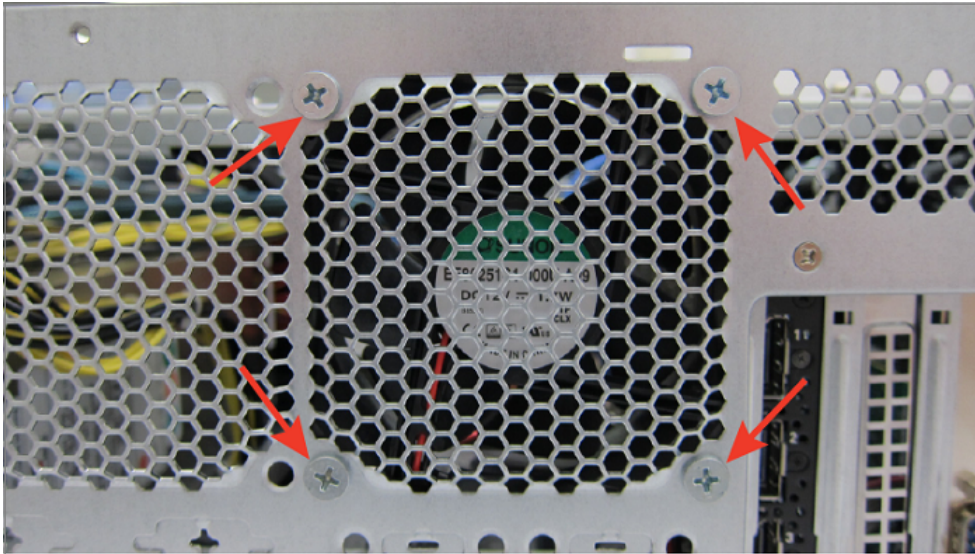

3. Connect the rear chassis fan power supply wire.

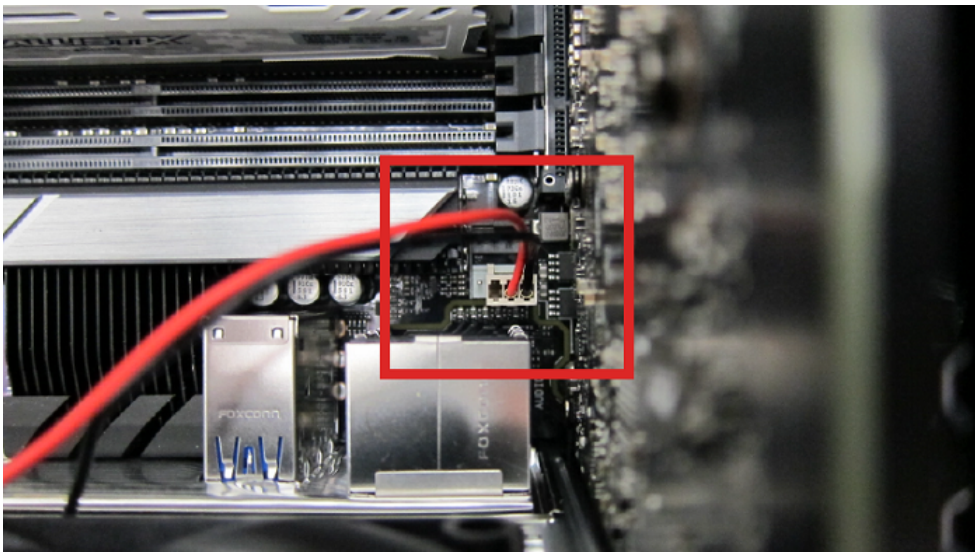

4. Replace the top panel.

Refer to the section [Removing and Reinstalling the Top Panel](#)<sup>32)</sup> for instructions.

## Replacing the System Drive Fan

This section describes how to remove and reinstall the system drive fan.

### To remove the drive cage fan:

1. Make sure the Voyager system is shut down.
2. Remove the top panel from the Voyager system.  
Refer to the section [Removing and Reinstalling the Top Panel](#) for instructions.
3. Disconnect the system drive fan power supply wire.

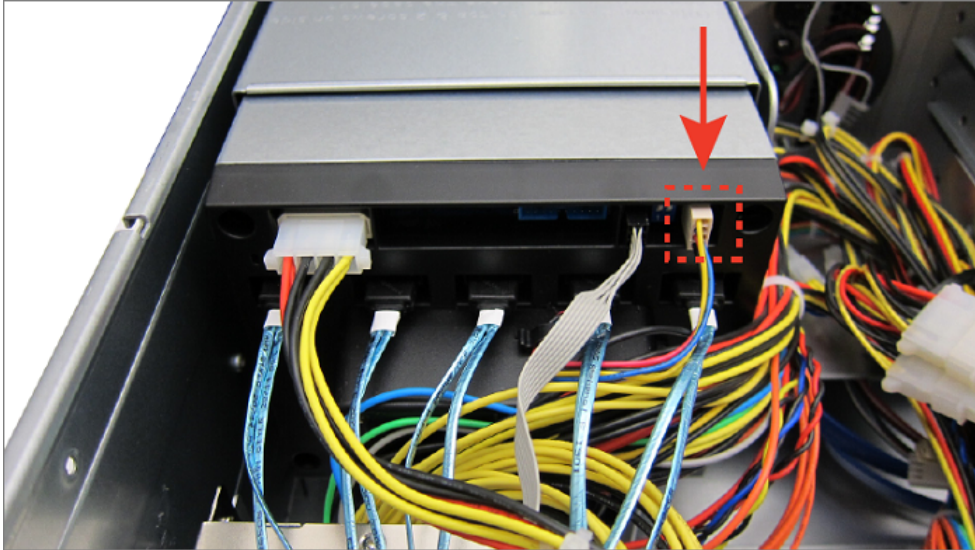

4. Remove the fan by pulling the system drive fan casing from the system drive cage.

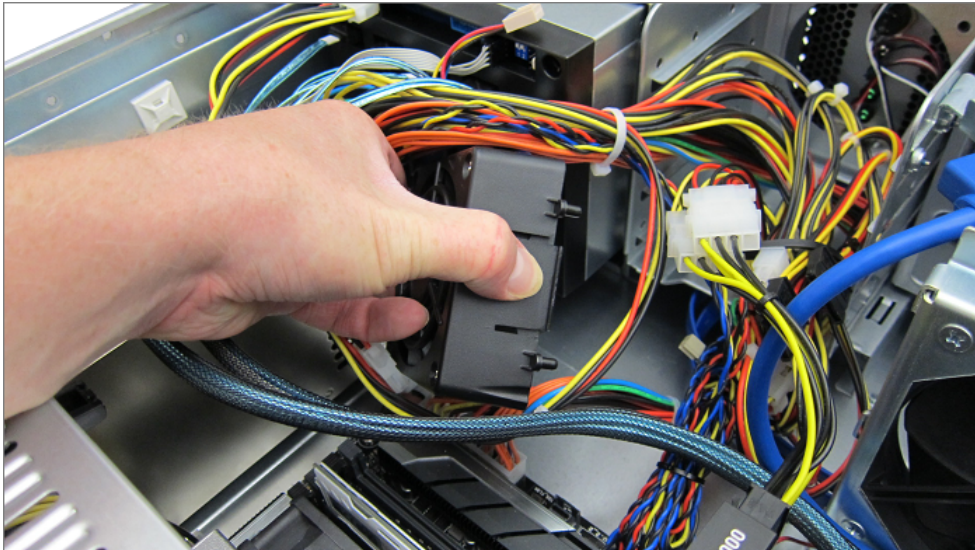

### To install the system drive fan:

1. Insert the system drive fan into the system drive cage.

The fan casing will click when the fan is secured to the system drive cage.

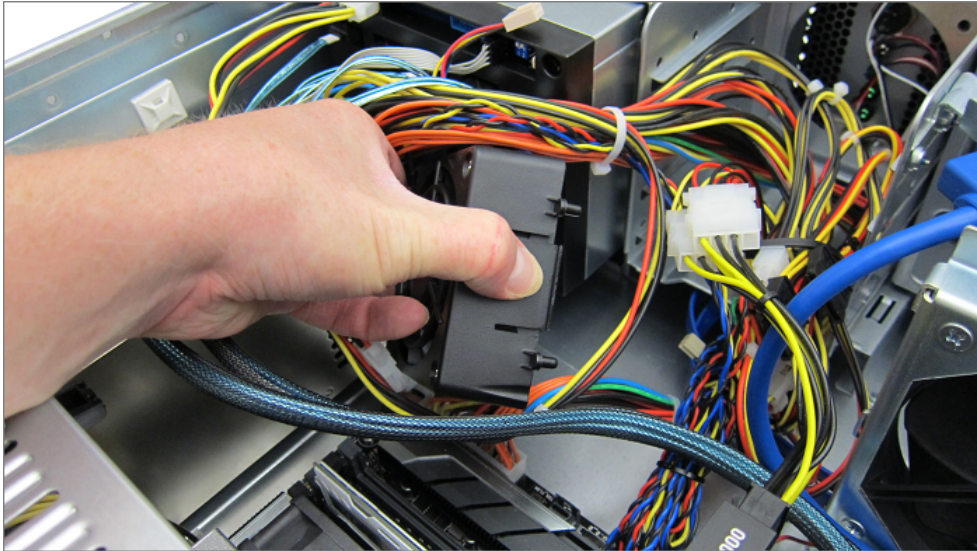

2. Connect the system drive fan power supply wire to the system drive cage.

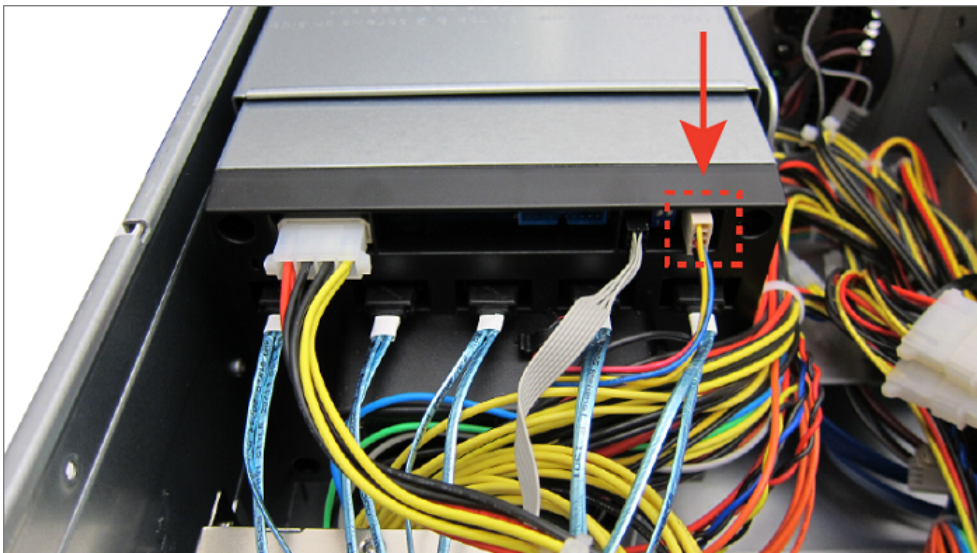

3. Replace the top panel.

Refer to the section [Removing and Reinstalling the Top Panel](#)<sup>32</sup> for instructions.

## Replacing Power Supplies

The Voyager system has two identical hot-swappable power supply modules, located at the rear of the system on the left-hand side. Since the system requires a minimum of one power supply module to operate, only one power supply can be hot-swapped at a time.



**Protective Earth** — *Static discharge can cause serious damage to sensitive devices. Touch the chassis to dissipate static charge before removing power supplies from the system, and exercise proper grounding precautions when working around the Voyager system.*

Keep the following safety information in mind while removing a power supply from the Voyager system:

- Always ground yourself before touching electronic equipment.
- When removing a power supply module, always support the module with two hands to help prevent dropping it.



**Warning** — *Hazardous voltages capable of delivering electric shock remain within the power supply module for a period of time after removal from the system.*

*Ross Video power supply modules are intended to be factory serviced by qualified Ross Video service personnel only. Users should only remove and replace the power supply modules.*

*When removing or replacing a power supply module, follow the instructions below:*

- *Disconnect the power cord from the power supply module or the power supply from AC mains before removing or replacing a power supply module.*
- *Do not open or try to remove the casing of the power supply module.*

*Failure to follow these instructions can result in death or serious injury.*

**To remove a power supply module from the Voyager system:**

1. At the back of the Voyager system, disconnect the power cord from the power supply module to be removed.
2. Loosen the thumbscrew on the bottom right of the power supply module.
3. Push up on the silver release lever.

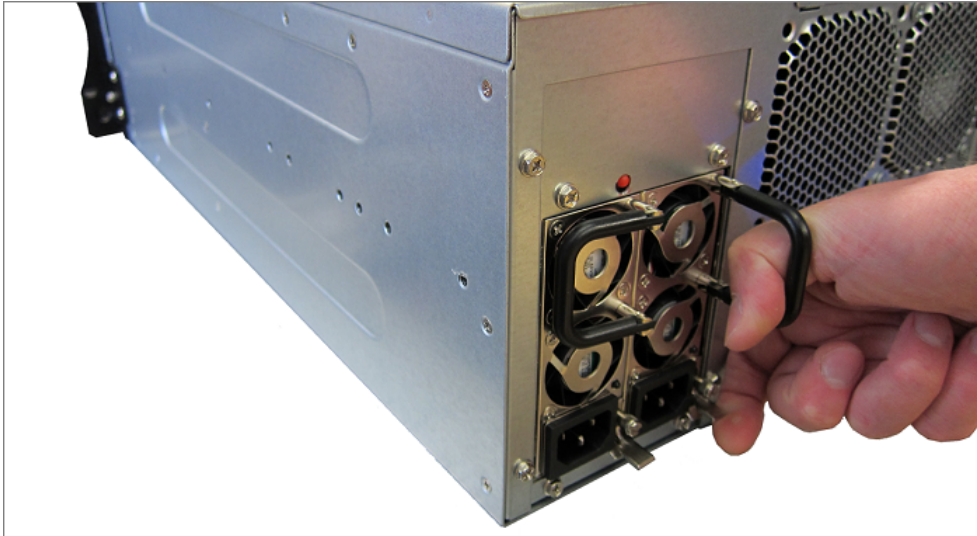

4. While pushing up on the silver release lever, hold the removal handle and gently pull on the power supply module to disengage it from the power supply bay.

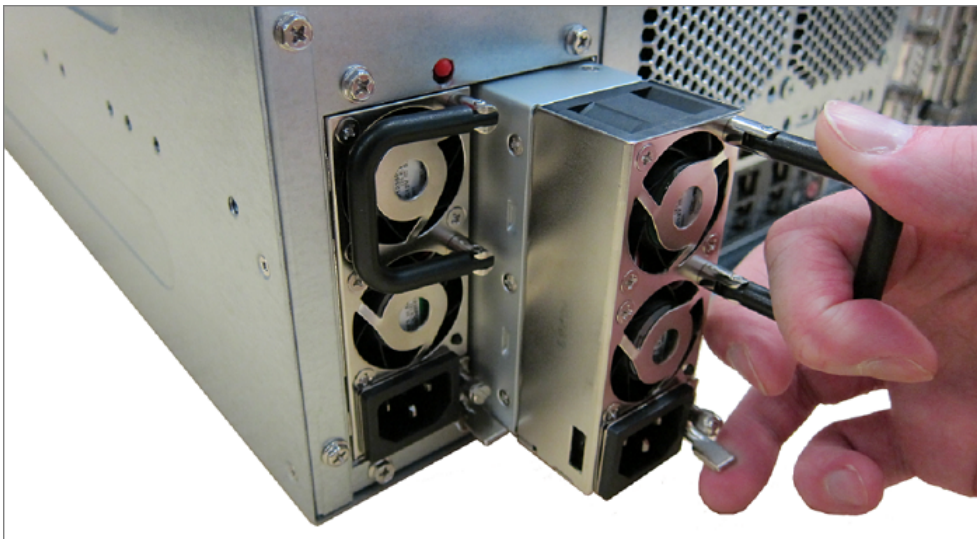

5. Support the power supply module with your other hand, and continue pulling until the module is completely removed from the power supply bay.

**To install a new power supply module in the Voyager system:**

1. In front of the open power supply bay, align the power supply module so that the silver release lever is positioned to the right-hand side.
2. Slide the power supply module into the open bay and push it firmly until it snaps into place.



3. Tighten the thumbscrew on the bottom right of the power supply module.
4. Connect the power cord to the new power supply module.

## Accessing the USB Security Dongle

You may be required to remove or replace the USB security dongle if instructed to do so by Ross Video Technical Support.

### To access the USB security dongle:

1. Remove the top panel from the Voyager system:

Refer to the section [Removing and Reinstalling the Top Panel](#)<sup>32</sup> for instructions.

2. Remove and replace the security dongle as instructed by Ross Video Technical Support.

The USB security dongle is located above the inside chassis fan behind the front chassis fan. The security dongle connects to the Voyager system via a USB interface.

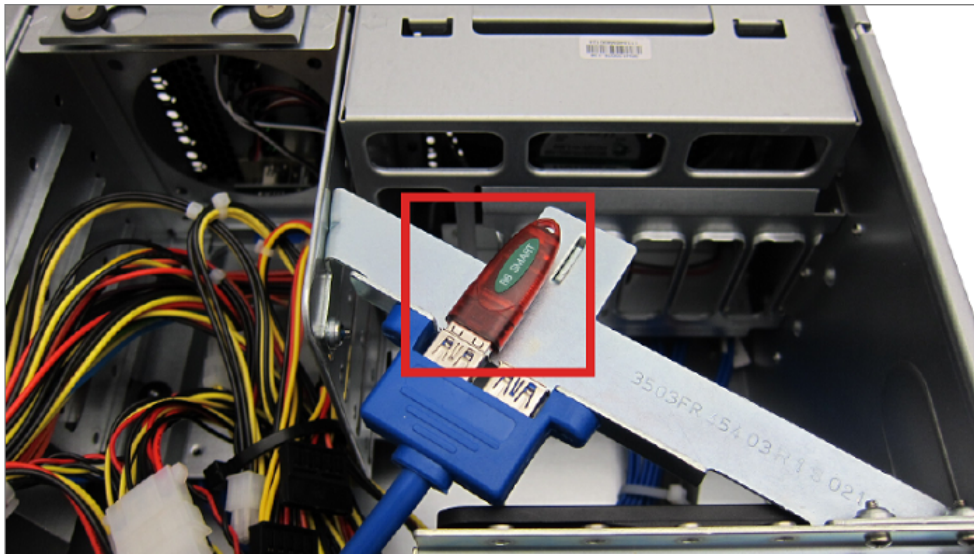

Use the additional USB interface to install an additional dongle if necessary.

3. Replace the top panel.

Refer to the section [Removing and Reinstalling the Top Panel](#)<sup>32</sup> for instructions.

# Appendix A: Matrox SDI I/O Cables

This appendix provides information on the Matrox video breakout cable connectors for the Voyager base system.

## Matrox SDI Video Input/Output Cables

Provides SDI video input and output.

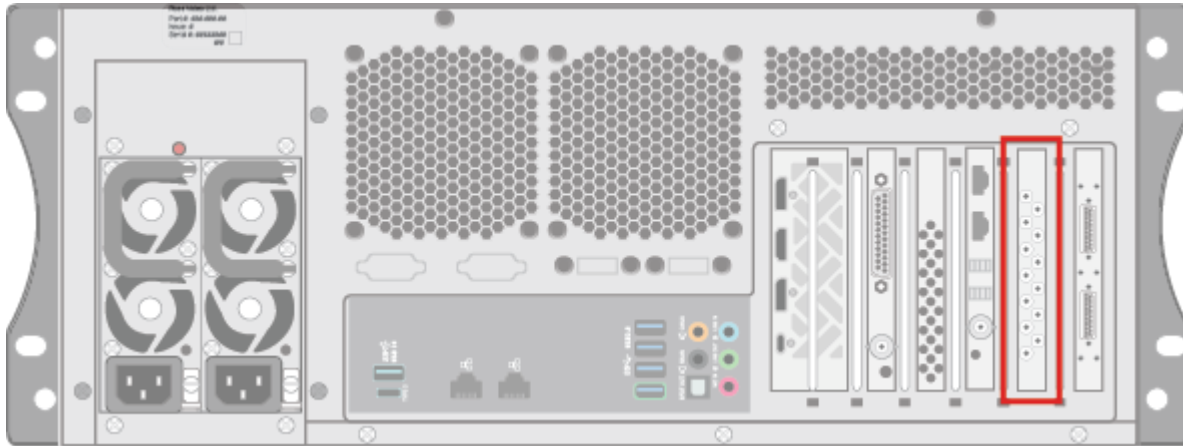

Matrox SDI Input/Output Connections

### DSX LE4 FH / 8 Model

SD/HD-SDI	Default (2 in, 6 out)	UHD Mode (8 out)	4 in, 4 out
1	In 1	N/A	In 1
2	Out 1 Fill	Fill 1	Out 1 Fill
3	In 2	N/A	In 2
4	Out 2 Fill	Fill 2	Out 2 Fill
5	N/A	N/A	In 3 (In 1 Key)
6	Out 1 Key	Key 1	Out 1 Key
7	N/A	N/A	In 4 (In 2 Key)
8	Out 2 Key	Key 2	Out 2 Key
9	Out 3 Fill	Fill 3f	N/A
10	N/A	Fill 4	N/A
11	Out 3 Key	Key 3	N/A
12	N/A	Key 4	N/A

★ Hardware bypass relays are present between 1 & 2, 3 & 4, 5 & 6, and 7 & 8.

# Matrox Audio Cables

Provide audio input/output.

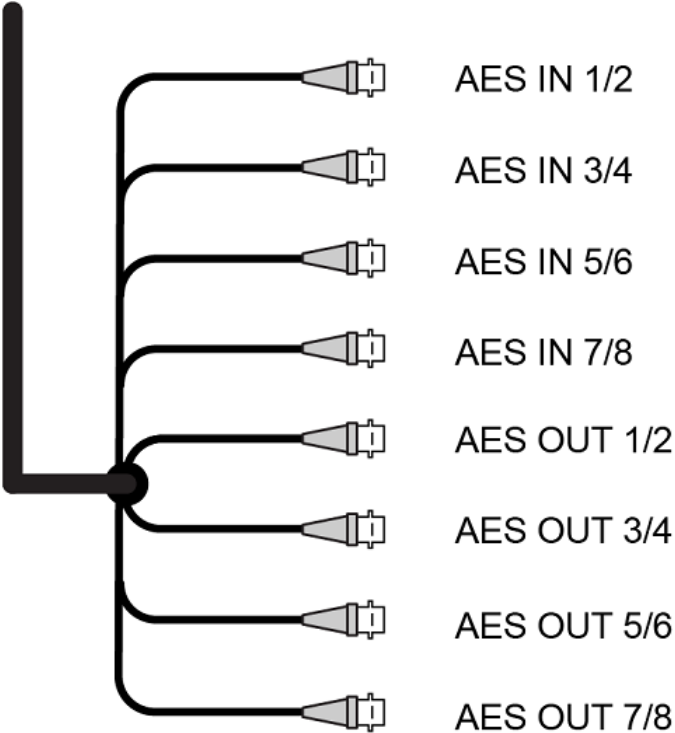

*Matrox Audio Input/Output Cables*

# Appendix B: Matrox 12G I/O Cables

This appendix provides information on the Matrox video breakout cable connectors for the Voyager base system.

## Matrox 12G Video Input/Output Cables

Provides SDI video input and output.

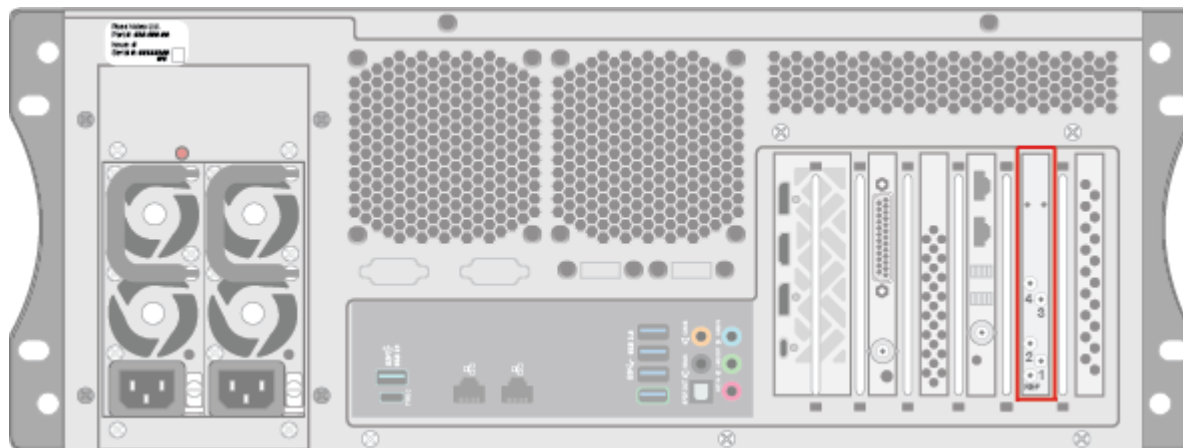

Matrox 12G Input/Output Connections

### DSX LE5 12G Model

Label	Channel (0 in, 4 out)	Channel (1 in, 3 out)	Channel (2 in, 2 out)	Channel (3 in, 1 out)	Channel (4 in, 0 out)
4	OUT F	OUT F	OUT F	OUT F	<b>IN F</b>
3	OUT E	OUT E	OUT E	<b>IN E</b>	<b>IN E</b>
2	OUT B	OUT B	<b>IN B</b>	<b>IN B</b>	<b>IN B</b>
1	OUT A	<b>IN A</b>	<b>IN A</b>	<b>IN A</b>	<b>IN A</b>

# Appendix C: AJA Corvid 88 I/O Cables

This appendix provides information on the AJA Corvid 88 BNC connections for the Voyager system.

The Corvid 88 high-density, multi-stream, multi-format Gen2 PCIe I/O card is designed for applications that require multiple simultaneous input and output streams and provides 8 BNC connections. Each BNC connection can be set programmatically as either an input or output and each can support a different video format, provided all formats use the same clock timing.

## Features

- PCI Express Gen 2.0 8-lane
- Up to 8 independent channels 3G, HD, SD-SDI I/O
- All SD/HD/2Kx1080/4K video formats
- 3G input/output for High Frame Rate (HFR) support
- 8/10 bit YCbCr and RGB frame buffer formats
- 4 independent Mixer/Keyer widgets
- 4 independent 16-ch 48kHz SDI embedded audio I/O engines
- Analog Color Black or HD Tri-Level Sync

## BNC Connections

The BNC connections are found at the rear of the Voyager box, as shown in the figure below.

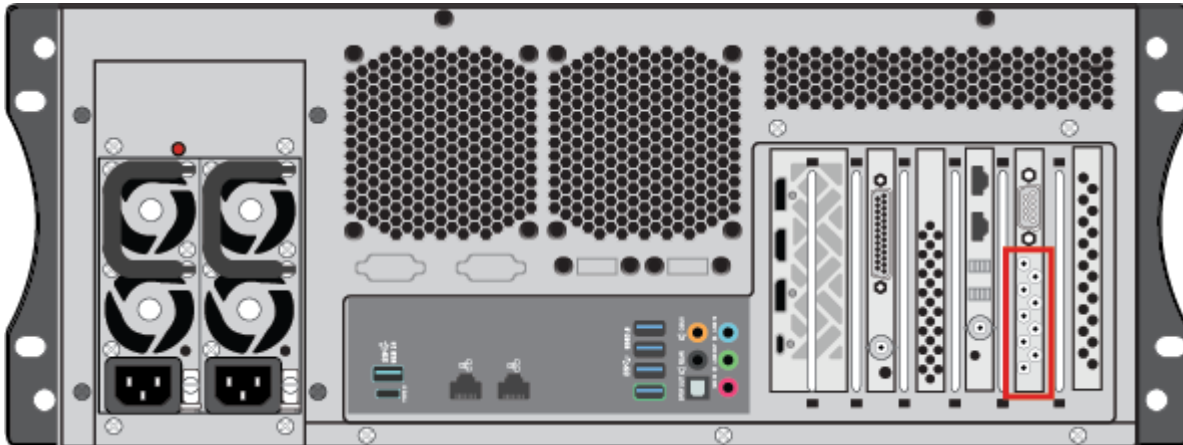

*BNC Connections*

# BNC Connection Pinout

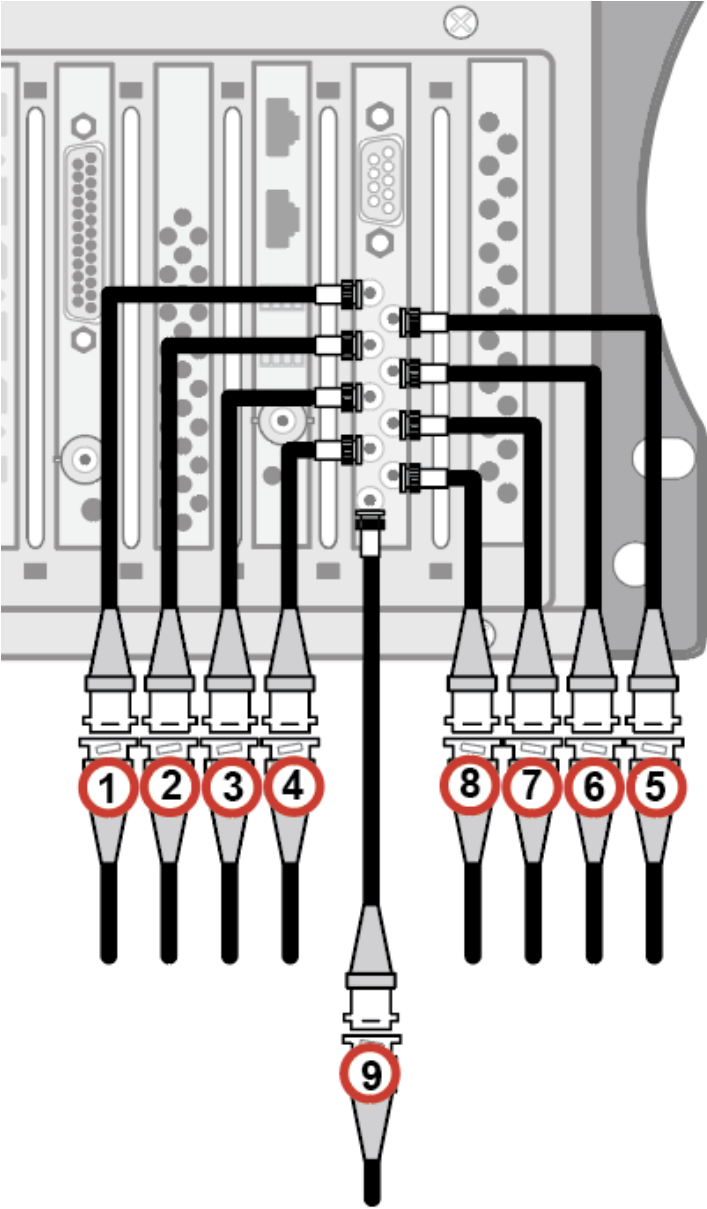

BNC Connection Pinout

1 to 4	3G-SDI Video input
5 to 8	3G-SDI Video output
9	House reference GenLock signal

## Contact Us

Contact our friendly and professional support representatives for the following:

- Name and address of your local dealer
- Product information and pricing
- Technical support
- Upcoming trade show information

<b>Technical Support</b>	<b>Telephone:</b>	+1-844-652-0645 (North America) +800 1005 0100 (International)
	<b>After Hours Emergency:</b>	+1 613 • 349 • 0006
	<b>Email:</b>	techsupport@rossvideo.com

<b>General Information</b>	<b>Telephone:</b>	+1 613 • 652 • 4886
	<b>Fax:</b>	+1 613 • 652 • 4425
	<b>Email:</b>	solutions@rossvideo.com
	<b>Website:</b>	<a href="http://www.rossvideo.com">http://www.rossvideo.com</a>

## Visit Us

Visit our website for:

- Company information and news
- Related products and full product lines
- Online catalog
- Testimonials