

FET-6945 GigE

Triple Link Ethernet Fiber Transceiver (WDM)

7 Port, Gigabit Ethernet switch with triple link, bi-directional fiber transceivers.

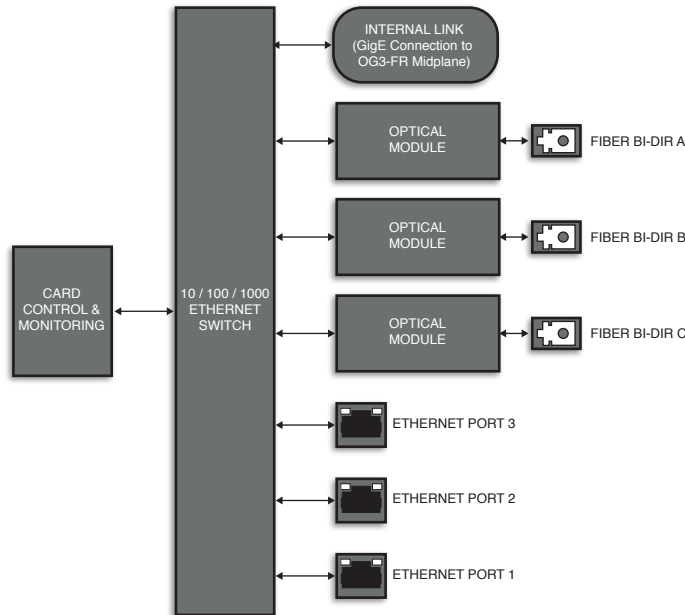
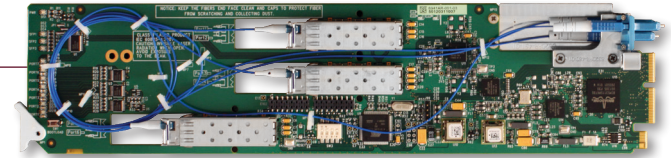

The FET-6945 is a dedicated 7 port, Gigabit Ethernet switch. 3 Copper ports provide 1Gb/s connectivity for multiple Ethernet enabled devices or links to additional network switches. 3 optical ports provide Ethernet links over three, bi-directional fiber connections for extended distances. An additional port is available for the OG3 frame's optional internal GigE controller.

The FET-6945 is available in 2 varieties: The FET-6945-20A/B transceiver pair is capable of running up to a 20km link between 2 transceivers. The FET-6945-40A/B transceiver pair is capable of running up to 40km link, by using a higher output power and higher receiver sensitivity SFP.

Using WDM (Wave Division Multiplexing), a bi-directional link can be obtained using 1310nm and 1550nm wavelengths over a single fiber link. When using WDM single fiber link, the two FET-6945 transceivers at each end of the link must complement each other in regards to their wavelength TX and RX.

Key Features

- 3 independent copper Gigabit Ethernet ports
- Copper Ethernet connection: RJ45
- 3 bi-directional single fiber WDM connections
- Optical connection: LC
- Internal GigE midplane connection
- SNMP compliant
- 5-year transferable warranty

Input Optical Sensitivity & Wavelength

- 20km A: -22dBm @ 1550nm
- 20km B: -23dBm @ 1310nm
- 40km A: -23dBm @ 1550nm
- 40km B: -23dBm @ 1310nm

Output Power & Wavelength

- 20km A: -8dBm @ 1310nm
- 20km B: -8dBm @ 1550nm
- 40km A: -3dBm @ 1310nm
- 40km B: -5dBm @ 1550nm

Ordering Information

Triple Link Ethernet Transceiver, Triple Fiber

FET-6945-20A	20km WDM 1310 TX / 1550 RX
FET-6945-20B	20km WDM 1550 TX / 1310 RX
FET-6945-40A	40km WDM 1310 TX / 1550 RX
FET-6945-40B	40km WDM 1550 TX / 1310 RX

Rear Module Suffix (ex: [model]-R2)

-R2 Rear Module for FET-6945

