

FET-6946 GigE

Triple Link Ethernet Fiber Transceiver (WDM & Dual Fiber)

7 Port, Gigabit Ethernet switch with triple link, dual bi-directional plus dual fiber transceivers.

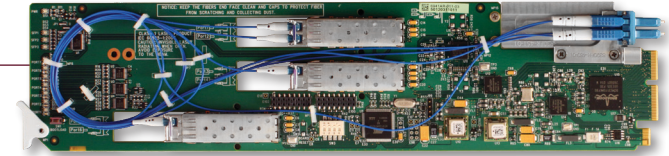

The FET-6946 is a dedicated 7 port, Gigabit Ethernet switch. 3 copper ports provide 1Gb/s connectivity for multiple Ethernet enabled devices or links to additional network switches. 2 optical ports provide 2 Ethernet links over two, bi-directional fiber connections and 2 additional optical ports provide a 3rd Ethernet link over dual fiber connections. An additional port is available for the OG3 frame's optional internal GigE controller.

The FET-6946 is available in 2 varieties: The FET-6946-20A/B transceiver pair is capable of running up to a 20km link between 2 transceivers. The FET-6946-40A/B transceiver pair is capable of running up to 40km link, by using a higher output power and higher receiver sensitivity SFP.

Using WDM (Wave Division Multiplexing), a bi-directional link can be obtained using 1310nm and 1550nm wavelengths over a single fiber link. When using WDM single fiber link, the two FET-6946 transceivers at each end of the link must complement each other in regards to their wavelength TX and RX.

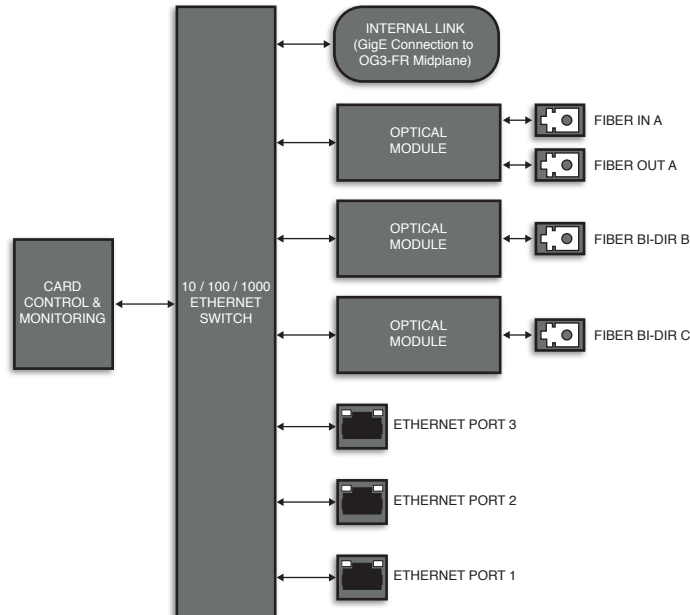

Ordering Information

Triple Link Ethernet Transceiver, Dual Bi-Directional plus Dual Fiber

FET-6946-20A	20km WDM 1310 TX / 1550 RX
FET-6946-20B	20km WDM 1550 TX / 1310 RX
FET-6946-40A	40km WDM 1310 TX / 1550 RX
FET-6946-40B	40km WDM 1550 TX / 1310 RX

Rear Module Suffix (ex: [model]-R2)

-R2 Rear Module for FET-6946

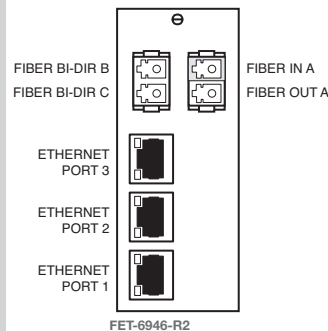

Key Features

- 3 independent copper Gigabit Ethernet ports
- Copper Ethernet connection: RJ45
- Quad fiber connection
- Optical connection: LC
- Internal GigE midplane connection
- SNMP compliant
- 5-year transferable warranty

Input Optical Sensitivity & Wavelength

- 20km A: -22dBm @ 1550nm
- 20km B: -23dBm @ 1310nm
- 40km A: -23dBm @ 1550nm
- 40km B: -23dBm @ 1310nm

Output Power & Wavelength

- 20km A: -8dBm @ 1310nm
- 20km B: -8dBm @ 1550nm
- 40km A: -3dBm @ 1310nm
- 40km B: -5dBm @ 1550nm