

# ADA-8402-A AES

## AES / EBU Distribution Amplifier – 75Ω

Broadcast quality AES / EBU distribution amplifier with internal audio processing.

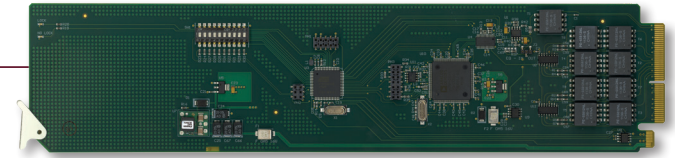

The ADA-8402-A is an AES / EBU distribution amplifier designed for broadcast use. It provides 8 copies of the incoming unbalanced AES3 signal when used with the -R2A full rear module or 4 copies of the incoming signal when used with the -R2AS split rear module. The ADA-8402-A supports audio sampling frequencies from 32kHz to 96kHz. Cable equalization and reclocking techniques enable the ADA-8402-A to recover the incoming digital audio signal reliably.

The ADA-8402-A also includes internal audio processing for independent channel gain, sum (mono), left or right channel only, and ITU1770 LKFS loudness measurements, which are displayed in DashBoard.

The -R2AS high density split rear module can accommodate up to 2x ADA-8402-A cards, each configured as a 1x4 DA, accommodating up to 20 channels of distribution per 2RU frame.

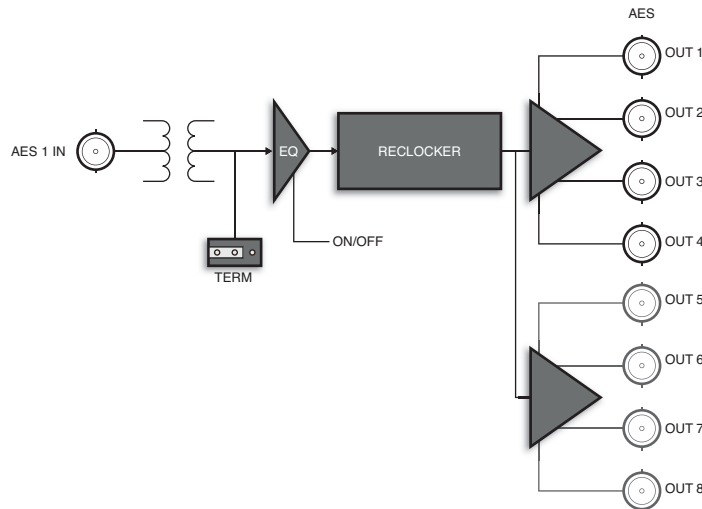

\* Only 4 analog outputs are available when using the -R2AS split rear module.

### Ordering Information

#### AES / EBU Distribution Amplifier – 75Ω

ADA-8402-A      AES / EBU Audio DA

#### Rear Module Suffix (ex: [model]-R2)

-R2A                      75Ω Rear Module for ADA-8402-A  
 -R2AS                    75Ω Split Rear Module for 2x ADA-8402-A

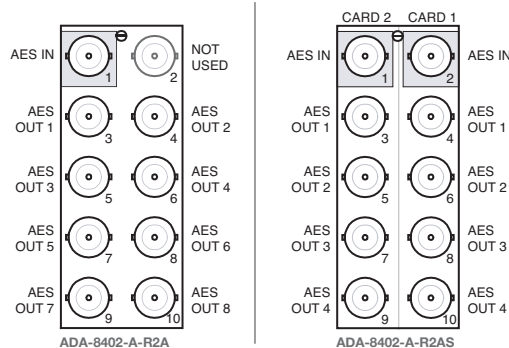

### Key Features

- 1x4 or 1x8 AES distribution amplifier
- Cable equalization and data reclocking on the incoming AES / EBU signal
- Supports audio sampling frequencies from 32kHz to 96kHz
- 75Ω unbalanced AES3 I/O
- Ideal for distributing Dolby® E and Dolby® Digital signals
- Provides level matching and level control of output signals
- 20 DAs in the OG3-FR
- 5-year transferable warranty
- Power: 2 Watts