



Delivering Ultra HD 4K Video to an On-Set HD Monitor Matrix

Displaying Ultra HD 4K Content in a Production Studio

Sometimes it's simply not possible to get live shots displayed behind the presenters in a live production studio. Shooting restrictions, time of day, inclement weather, or the immediacy of a breaking news story all create such barriers. Any number of reasons may result in the need to display Ultra High Definition 4K video behind your presenters, from pre-recorded content. Perhaps you need to display video captured from a 4K camera—showing all the action, up-close and personal—on your set. For a variety of reasons, studio producers are looking to employ Ultra HD 4K video within their on-set displays.

Dissecting the Problem

The problem with feeding large on-set displays a conventional HD signal is that the lack of resolution causes the images to appear soft. To maintain a 16:9 aspect ratio, this kind of multi-panel display ends up with many less pixels per panel than would be required to display the image on a single display.

Very large 4K on-set video displays can be created in a variety of video wall configurations. A video wall matrix processor—such as a Vista Systems URS or Spyder—processes the 4K video to divide, scale and perhaps rotate the output channels to match the number and orientation of the monitors contained within the display matrix, such as the 12-screen image above.

HD 1080p monitors exist today with near-zero bezels—that is, when positioned against each other there is practically no gap between the monitor rasters. Other HD monitors have a larger bezel, and the joined rasters don't create a seamless gap. To overcome this, the set designer may employ a strip of material between each monitor which covers the non-display part of the screens—to create a “window frame-like” effect.

Key Highlights

Application

Playback of Ultra HD 4K Video within Studio On-Set Display Matrix

The Challenge

Using multiple 1080p HD monitors to display Ultra HD 4K Video

The Solution

A cost-effective, Ultra HD 4K production server with integrated file-based workflow

Benefits

- Cost-effective solution to create seamless on-set Ultra HD 4K Video
- Integrated workflow substantially streamlines Ultra HD 4K production process
- QuadView Display dramatically reduces cost and complexity of Ultra HD 4K display in control room

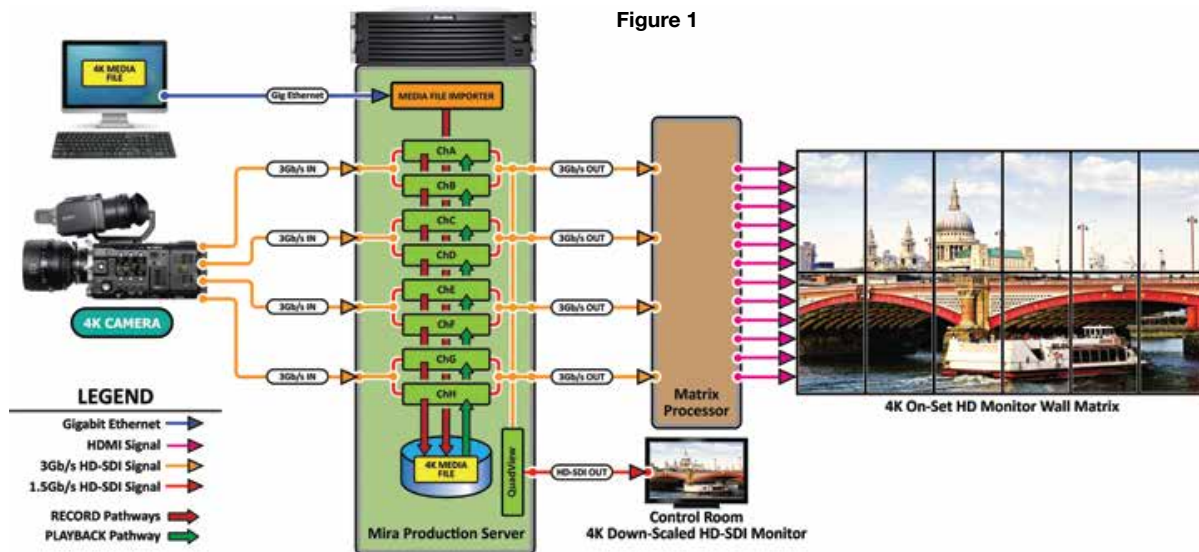

Figure 1

As a less expensive alternative to multiple displays driven by a video wall matrix processor, a 4K rear projector can be used if space within the studio permits. Figure 1 illustrates a typical configuration in which an Ultra HD 4K video camera feeds an Abekas Mira Production Server, via single coaxial cables carrying a multiplexed 3Gb/s serial digital video signal. Four such cables deliver the full-resolution progressive-scanned Ultra HD 4K digital video to the Mira. The server creates a single 4K media clip which is distributed across eight separate channels via base-band real-time recording.

Another method of transferring Ultra HD 4K content into Mira is to use the integrated Media File Import utility. The Abekas Mira QuadView monitor output provides scaled-down 4K video onto a single HD-SDI picture monitor, dramatically reducing the cost and complexity of 4K monitoring in the control room.

Uniquely Configured to Deliver 4K Content

As described above, Ultra HD 4K content can be delivered to Mira by either four 3Gb/s coaxial cables, or via the integrated Media File Import utility. This integrated software application, part of the standard media management suite of software included in every Mira server, ingests full-resolution 4K source media files and automatically “tiles” that incoming 4K content into eight separate video tracks contained within a single “4K” media file stored within the Mira Clip Library. When this 4K media clip is later loaded and replayed during on-air production, all eight video tracks instantly load into all eight video channels with a single command—with 100% guaranteed synchronous playback with each other—to accurately replay the entire tiled Ultra HD 4K video within the on-set monitor matrix.

Save Time and Increase Accuracy with Mira’s Streamlined 4K Workflow

Unlike competing video servers, Mira’s Media File Import tool completely eliminates the need to “manually tile” the 4K content with an external editor into eight separate media files. Also eliminated with Mira is the subsequent management and importing of the eight separate “tile” media files—each of which must also be painstakingly mapped and manually loaded by an operator at time of playback—in order to match each tile to the proper video monitor within the on-set monitor matrix. With Mira, media file ingest of Ultra HD 4K source content is radically streamlined—and completely eliminates the inevitable production mistakes encountered when handling separate media file “tiles” as found in the workflows just described for competing video servers.

Seamless Playback of 4K Images

Triggering the 4K media clip playback in Mira requires just a single command for all eight video channels (not eight commands, as required in competing servers); and can be accomplished in multiple ways. For single- or multi-clip 4K playback, the included Mira Explorer graphical user interface application can be used. The 4K media clip files can also be loaded and triggered from external production switcher control or automation systems utilizing either Odetics or Louth VDCP protocol via RS422 control—for predictable, instant and seamless 4K clip loading and playback.

Contact us today, to find out how Abekas Mira Production Servers can deliver Ultra HD 4K video to your live television production set, in an extremely streamlined and cost-effective manner!